

OH-02
29849

DEPARTMENT OF DEFENCE

LIBRARY

CLASS
NUMBER

04.02

ACCESSION
NUMBER

29849

29849

Library
RESTRICTED.

COMMONWEALTH NAVY ORDERS

I N D E X

OF

NAVY ORDERS

1944

COMPRISING

NAVY ORDERS ISSUED BETWEEN

1st JANUARY, 1943, and 31st DECEMBER, 1944

and

LIST OF NAVY ORDERS CANCELLED

SUBSEQUENT TO 1st JANUARY, 1939.

(This Index is published at the end of each half-year.)

DEPARTMENT OF DEFENCE
LIBRARY.

Photo-lithographed, by Authority:
H.E.DAW, Government Printer, Melbourne. 04.02.

P.3025

ACCESSION
NUMBER29849.....

INDEX

Subject	C.N.O. or C.C.N.O. No.
A	
A.A.Co-operation with Military Defence in Harbour	†88/45
Fire Control - Calibration Procedures for A.B.U. and Type 285	†225/44
Gunfire from H.M.A. Ships in Harbour	†77/45
Machine Guns, Annual Practice Allowance of .505" - Ammunition for	†7/45
Targets - Kites and Drogues for - Discontinuance of Supply	146/44
Weapons, Short Range, Eyesighting Sights	148/45
Able Seamen - R.A.N.V.R. - Allocation of, to General Service ..	176/44
Abnormal Expenditure - Accumulators	181/44
A.B.R. 252 - Signal Cards - Issue to Ordinary Seamen V/S ..	288/45
A.C.B. 247 (R) Issue	†85/44
Access to Compartments situated below the waterline which are to be manned at sea	255/44
Accidents - Guns	28/44
- Naval Motor Vehicles	56/44
- Revolvers	86/44
- Sustained by members of the services and damage to railway property - personnel travelling by train	200/45
Accommodation - Rail - Adelaide to Melbourne	97/44
Accountant Branch Examinations	648/44
Ratings - Temporary Commissions	366/44
Officer, Inspecting	428/45
- R.A.N., Kilindini, Address for Mail	†91,249/45
Accounting for articles purchased from Canteen Funds	649/45
Consignments of Victualling Stores delivered to H.M.A. Ships in a deficient or damaged condition	256/45
Consumable Naval Stores in Merchant Vessels commissioned for Naval Service	366/45
Machinery, Machine Tools, etc. supplied for Naval Workshops	108,584/44
Naval Armament Stores	385/45
Stores - H.M.A. Motor Patrol Boats and other small vessels in which accounts of con- sumable Naval Stores are not required to be maintained	652/45
Purchases and Issues of Fruit in Provision Accounts of Ships and Establishments	501/45
Naval Armament Stores - Small Vessels and Boats	222/45
Procedure in H.M.A. Establishments - Naval Store - Bedding issued to Chief Petty Officers, Petty Officers and W.R.A.N.S.	506/45
- Naval Armament Stores in D.E.M.S.	515,615/44
Store - Frigates	244/44
Accounts - Armament Store - H.M.A. Ships etc. - Consumable Stores	285/44
for Provisions - Necessity for prompt payment	217/44
Supplied to Tenders when absent from Parent Ship	385/44
- Naval Armament and Torpedo Store - Errors and omissions, etc.	612/44
Store - Transfer of charge between Storekeeping Officers	251/45

† Denotes C.C.N.O.

Subject	C.N.O. or C.C.N.O. No.
A - contd.	
Accounts - contd.	
- Pay and Service Certificates - H.M.A. Ships attached to Eastern Fleet	57/44
- R.A.N. Destroyers and A.M.S. attached to Eastern Fleet	413,512/44
Acid for Canteens - Supplies of Citric	281/45
Acting Higher Rank - Retention of	452,650/44
Leading Stokers - Confirmation and qualifications for Stoker Petty Officer	518,585/45
Petty Officers - Irregular wearing of Class III Uniform Rank or Relative Rank of Lieut.-Commander - Naval Reserves - Grant of	106/44
Action Rations	607/44
Repair and Fire Fighting Materials - Stowage for - Minor War Vessels	645/44
to be taken on receipt of New Weapons	†179/44
Adaptometer - A.R.L. Mk.III - Classification of Night Vision by Additional Armament - Gate Vessels and Boom Working Vessels ..	618/45
Address for mails - R.A.N. Accountant Officer, Kilindini ..	345/44
of Commander-in-Chief, Eastern Fleet	†57/45
R.N. Ships and Authorities	249,†91/45
Addresses - Seaward Defences	†90/45
Adelaide Railway Station - Military Cloak Room	543/45
Adjustments - Inter-Departmental - Suspension in War-time ..	†22,†60,†150/45;†136/44
Administration - Landing Ships	513/45
of Oaths etc. to Members of certain Forces - Regulation 63 of the National Security (Supplementary) Regulations	429/45
Admiralty Fleet Orders 1024 and 1025/45 - Weapon Maintenance ..	†208/44
and Confidential Admiralty Fleet Orders	522/45
Admission of Naval Personnel to Mental Hospitals or Receiving Houses ..	606/45
Adult Education in the R.A.N.	178/45
Advance Supply Notes - Despatch of for Naval Stores Shipped etc. from H.M.A. Naval Store Depots	160/44
Advanced Base Ports - Fire Fighting Equipment	594/45
Advancement - Communications Branch	642/44
- Mechanics - in War-time	512/45
of Communication Ratings in (or attached to)	105/45
Combined Operations	448/45
Ratings during the War	557/44
Serving in Services Reconnaissance Department, Far Eastern Liaison Office and Allied Intelligence Bureau	576/45
- Small ships	667/44
Trained in Combined Operations	413/45
Recovered Deserters to Able Seamen of equivalent rating	649/44
Wiremen	26/44
to Chief Rate - Artificers etc.	556/44
Petty Officer - R.A.N.R. Petty Officers Shipwright - Qualifications	528/45
Petty Officer - Radio Mechanic Branch	290/44
- W.R.A.N.S. - W/T Ratings	322/44
Advances - Cash - for Fighting French Warships	360/44
Advertisements, Press	470/45;275/44
Aerial - Radar - Y.F.P. - Modifications	†75/44
Training System A/SI and A/S3 - Modification to Radar Types A272, A286 P/Q	294/45
	†168/44
	†81/44

† Denotes C.C.N.O.

Subject	C.N.O. or C.C.N.O. No.
A - contd.	
Africa Star, Star 1959-45 and Mention in Despatches Emblem	466/45
Agencies - Commonwealth Savings Bank - Commission	85/44
Agreement for the Supply of Officers' Uniforms - Inclusion of Uniforms for Nurses and W.R.A.N.S. Officers	220,350/45
Agreements - "Knock for Knock" - Navy Vehicles	108,519/45
Aircraft Operating from H.M.A. Ships - Emergency Rations for ..	87,445/44
Airgraphs	364/44
Air Mail - India - United Kingdom	365/44
Mails	620/44
or Sea Freight - Stores consigned by - to Northern Operational Bases	167/44
Raid warnings, harbour signals to denote	†25/45
Sea Rescue Vessels - Allocation of Names	412/44
- Physical Standard of Personnel serving in	558/44
Alarm Signals for A.M.S. Vessels	644/45
Allocation of Radar Equipment	†142/44
R.A.N.V.R. Able Seamen to General Service	176/44
Allotments of Members of the R.A.N. who are reported killed, presumed killed, missing or prisoners of war	199/45
Allowance - Captain of Heads	258/44
- Dragnets	511/45
- for Charge of Naval Armament Stores - Payment of - H.M.A. Shore Establishments	574/45
Use of Private Motor Cars	277/45
- Non-specialist for Warrant Officers appointed in lieu of those who have passed Gunnery Course	214/45
Allowances of Accessories - Authorised (Test Equipment) for ..	
Australian Type Radar	†140/44
Cartridges S.A. .303 - Revised	†257/44
Table Linen and Table Napkins	517/45
- Star Shell	†128/44
"All Services" Small Arm Ammunition - Accounting for	527/45
Alterations and Additions - Access for compartments situated below the waterline, which are to be manned at sea	255/45
Alteration(s) and Addition(s) - A.M.S. Vessels - A.F.O.589/45 ..	†52/44
- Asdic Installations - Fairing of Shell Plating C.A.F.O. 2163/45	†102/44
- Fitted for Mine-sweeping - Spur for Additional Signal Halliards	†118/44
- Hailing Equipment A.F.O.596S/45	†108/44
- Stiffening of Seatings - Kelly and Lewis Steam driven Generators	†104/44
- Voice Pipe Communications	†105/44
- Depth Charge Pattern Control Introduction	†121/44
- Fairmile Patrol Boats Type "B"	†195,†229/44
- C.S.A. Smoke Apparatus and Type "F" Smoke Floats	†209/44
- Firefighting in H.M.A. Ships A.F.O. 5595/45	†97/44

† Denotes C.C.N.O.

Subject	C.N.O. or C.C.N.O. No.
A - contd.	
Alteration(s) and Addition(s) - contd.	
- Range Transmitter from Radar to Transmitting Station ..	546/44
- V.H/F. R/T Sets - Fitting of ..	123/45
- 72 ft. H.D.M.Ls. ex U.S.A. ..	†256,†291/44
to Jackets of Petty Officers and Men not dressed as Seamen	245/45
- Reduction in Contract Prices ..	264/45
Amendment to "Official Memorandum - Prices of Clothing, etc. Maintained for issue on repayment to Ships' Companies" - dated 1st May, 1945 ..	51/44
of Form A.S.151 - Consumable Naval Store Ledger Sheets	246/44
Amendments to Drill - B.R.274/41, Handbook and Drill for 20 m.m. Oerlikon Machine Gun	571/45
- Quarter Bills	189/44
- "All Services" Small Arm - Accounting for ..	527/45
- Ball .503" - Replenishment of Army Stocks at Outports	202/45
- Boxes C222 and C199	2,278,416/44
- Carriers Quadruple and Carriers Shell Quadruple - Transfer to Gunmounting Department	182/45
- Cartridges, 40 m.m. Bofora H.E. with Primers No.18 - Withdrawal - Report	580/44
Expenditure Returns - Monthly	†271/44
- For Oerlikon Guns - Pools Maintained at Ports and Outfits to be supplied ..	†5/45
- Practice	525,586/45
- Gun Armament Material - Failure of - Form S.1148	294/44
- Gun, Reserves of, at Australian Ports and in A.S.I. Ships	†6/45
- Lighters - Loading for Ocean Passages	†199/44
- Miscellaneous A.A.D.Weapons - Rails, Propelling Rocket U2 in Mk II	42/44
- Propelling Rockets U2 in Mk.II and III, Kirby Lots 52, 53, 156, 178, 179 and 182 - Restriction	152/44
- Outfits of Small Ships	525/44
- Arrangements for Periodical Exchange, Examination etc.	612/44
- Pyrotechnics and Rockets, Signal - Star Shell - All Calibres - Minimum Range at which satisfactory functioning can be expected	195/44
- Reconditioned Q.F. 2-Pdr. H.E.H.V.	†145/44
- R.U. - Excessive Temperatures of	186/45
- Small Arms - Allowances for Shore Bases	†74/44
- Stock Reports	166/44
- Supply to Northern Bases	†145/44
- Unserviceable American - Disposal of	†78/44
- Weekly Report of Stock	472,589/45
- by Shore Establishments on Form A.O.5Z	526/44
- 4" - Hand up Chutes for - Modification	†180/44
- 20 m.m. Oerlikon - Clearing Charges	151/44
- 20 m.m. and 2-Pdr. - 20 m.m. Oerlikon H.E. - Liability to Caps of Cartridges Blowing Out, when Modified Breech Face Piece (Mark II) are fitted - Withdrawal of certain lots - Reports	142/44
- 20 m.m. Oerlikon H.E. Lot H.N.C.13 - Withdrawal ..	508/44
N.F.E.404 - Withdrawal	510/44
T.P.C.746 - Withdrawal	487/44

† Denotes C.C.N.O.

Subject	C.N.O. or C.C.N.O. No.
A - contd.	
Ammunition - 20 m.m Oerlikon H.E. - contd.	
Tracer Lot N.F.H.2257 F -	
With-drawal	507/44
10B/45 -	
With-drawal	508/44
- .503" for A.A. Machine Guns - Annual Practice Allowance of	†7/45
A.M.S. Vessels - Additional Kit Lockers	†41/44
Ventilation to Galley and Commanding Officer's Cabin	†157/45
- Alterations and Additions	†50,†108/45, †164,†231/44
- A.F.O.389/45	†52/44
- Asdic Installations - Firing of Shell Plating C.A.F.O.2165/45	†102/44
- Depth Charge Throwers Mark II Replacement by Mark IV - C.A.F.O. 1964/45, paragraph 2(a)	†86/44
- Fitted for Minesweeping - Spur for additional Signal Halliards	†118/44
- Fitting of D/F Equipment A.W.A.Type C.145A	†85/44
Single Bofors Mounting	†176/44
- Hailing Equipment - A.F.O.3965/45	†108/44
- Lockers for Fire-fighting and Action Repair Materials	†65/44
- Modification to Auxiliary Steam Line in Boiler Room	†49/45
- Stiffening of Seatings - Kelly and Lewis Steam Driven Generators	†104/44
- Voice Pipe Communications	†105/44
- Anchor buoys in	622/45
- And Frigates - Modification to Evaporator System	†68/44
- Armament	115/45
- A/S Type 128 or 128A where fitted - conversion to A/S Type 128B or 128C	†139/44
- Canvas Flag Wicket for	114/44
- Close Range Armament when Single Bofors is fitted	†205/44
- Contamination of Boiler Feed Water with Oil Fuel	275/44
- Deterioration of Cast Iron Condenser Doors ..	11/44
- Efficiency of	†48/45
- Exchange of Ammunition in	520/44
- Fitted with L.L. Sweeping Equipment - Protection of L.L. Sweep Switchboards	25/45
- Brown Type "A" Gyro Compass	590/44
- Fitting of Balance Weights to Crankshaft of Kelly and Lewis Steam Driven Generators	†105/45
V.H/F. R/T Set	†117/45

† Denotes C.C.N.O.

Subject
A - contd.

A.M.S. Vessels - contd.		
- Gardner Diesel Engines for "L.L." Sweeps - Circulating Water Header Tanks	479/44	
- Guard Rail Stanchions on Forecastle	†166/44	
- Gunnery Communications	†7/44	
- Installation of Permanent D.G.	†58,†82/45	
- Kelly and Lewis Steam Driven Generating Sets - Governors	310/45	
- Landing of Awnings, etc.	561/45	
- "L.L." Cable Drums - Stiffening of Hand Winding Gear	545/44	
Lead - Modification to	†258/44	
Sweep Reel - Failure of Hand Winding Gear	559/44	
- 57/3 Cells for "L.L." Sweeps	†8/44	
- Machinery of - Necessity for Purity of Seawater	86/45	
- Main Circulating Water Inlet Pipes	518/44	
- Maximum Continuous Power	†162/44	
- Modification of - to Steam Driven Boiler Room Fans to Firemain at Station 54	195/44	
- Monthly Report of Consumption of Fuel Oil	370/44	
- P.A.C. Projectors	257/45	
- Rockets	†151/44	
- Packing for Auxiliary Machinery	88/44	
- Parallel Running of Steam Driven Generators in	415/45	
- Pitting in Engine Room Bilges	54/45	
- Propeller Shafts	†69/44	
- Radar in	†82/44	
- Refrigerating Plant for Cold Room	†9/44	
- Refit at Port Adelaide - Replenishment of Naval Stores	210/44	
Removal of Helmsman's Splinter Proof Shelter	54/44	
Repainting of	†204/44	
Stability	110/44	
Steam Drenching Arrangements in Engine Room and Boiler Room	†69,†111/45;†177/44	
Steel Chests for	†15/45	
Towing Hawser	417/45;†82/44	
Use of Fore Peak for Trimming Ship	401/45	
Ventilation of Naval Stores	†45/44	
Wardroom Pantries	†51/45	
- Vibration of Steam Driven Boiler Room Fan Engine	†89/44	
Anchor Buoys in A.M.S. Vessels	†125/44	
Annual Census - Office Machinery	622/45	
Inspection of Explosives ex H.M.A. Ships	22/44	
Practice Allowance of .305" Ammunition for A.A. Machine Guns	111/44	
Anti-Aircraft Targets - Kites and Drogues for - Discontinuance of Supply	†7/45	
-Cholera - Inoculation	146/44	
-Gas Clothing - Oilskin - Upkeep and Repair	675/44	
-Eye Shields and Ointment - Revision of Allowances	21/44	
Protection	209/44	
Respirators - Containers	549/44	
Painting of Haversacks	†145/45	
Tubes connecting	382/44	
-Glare Spectacles - Pattern 4074 - Supply	†75/45	
Polarised Sun Glasses - Replacement by	50/44	
-Malarial Measures for Operational Forces Destined for Service in Malarious Area	281/44	
Supply of Stores for	418/44	
Supply of Stores for	15/44	

† Denotes C.C.N.O.

Subject
A - contd.

Anti - contd.		
- Sabotage Measures by H.M.A. Ships in Harbour	†76/45	
- Ship Fire Control - Communications - Radar Observation of fall of Shot	†259/44	
Apparatus A.D. Type D. Rockets Mark III - Restriction on Lots 452, 480, 511 and 515	599/45	
Testing Adjuster - Modification for Marks XIII and XIII* Depth Charge Pistols	545/45	
Appliances, Lifesaving - Provision	252/45	
Application(s) for Payment of Difference in Pay to Ratings performing Higher Duties - Naval Financial Regulations and Instructions, Article 74 from Naval Personnel for Release or Leave Discharge	565/45	
Discharge	527/45	
Discharge	205/44	
Appointment(s)	516,877/44	
and Instructions - Rehabilitation Officers	215/45	
- Naval Control Service Office, Gladstone	75/45	
Port Division Naval Medical Officer - Geelong	622/44	
Where date is to be reported - Reports	352/44	
Apprentices - War Service	291/44	
Armament - Additional - Gate Vessels and Boom Working Vessels Depot, R.A.N. Fremantle and Mine Depot, Byford	†37/44	
- Naval Depot, Darwin	†89/45	
- H.M.A. Ships - Additional Fitting of	†146/44	
Material and Ammunition - Failures of - Rendering of Forms S.1148 (h), (i) and (j)	†46/44	
Store Accounting Officers	294/44	
Accounts, Naval - To be transmitted by Registered Parcel Post	458/45	
Matters - Naval - Correspondence on - Naval Officer-in-Charge, Brisbane	355/45	
Officer-in-Charge, Brisbane	174/44	
Arms, Small - Establishment for Shore Bases	†20/44	
Army Form W.5192 Duty Free Concessions for Gift Parcels sent to the United Kingdom from H.M. Forces Overseas	444/45	
Medical Facilities - Use of in Transfer of Invalids	641/44	
Salvage Service - Salvage of Condemned, Unserviceable etc. Stores	267/44	
Arrangements in respect of the Agreement between U.K. and Australian Governments for H.M. Ships transferred to R.A.N. for manning	†51,227/44	
Arrests of Deserters and Absentees - Warrants for	451/45	
Articles Duty-free for H.M.A. Seagoing Ships	28/45	
Artificers, Electrical and Ordnance and Shipwrights - Difference of Pay	248/45	
A/S and Radar Maintenance Vessels - Naming of	†196,†260/44	
Directing Gears; Pattern A.810 - Types 128 and 144 Series	†185/44	
Domes - Losses of and Damage to	†18/45	
Equipment - Half-yearly Reports on - Record of Personnel in M/Ls - R/T Interference	†148/44	
Sets Fitted with Electrical Training Brushes for Motors	61/44	
Patt.9955 and 9956	†265/44	
Type 128 - Directing Gear	†84/45	
or 128A where fitted - A.M.S. Vessels - Conversion to A/S Type 128B or 128C	†159/44	
Testing Equipment - Fairmiles and H.D.M.Ls.	†74/45	
W/T. Radar, etc. Equipment - Establishment Lists	511/44	
Asbestos Clothing for Fire-Fighting	621/45	
Audio Equipment Half-Yearly Reports on	†19/45	
Gear etc. - Precautions to be taken to prevent damage to Drydocking H.M.A. Ships	325/45	
Installations Types 144/5 - Training of Personnel	†70/44	
Recorder Paper Rolls	†55/45	

† Denotes C.C.N.O.

Subject	C.N.O. or C.C.N.O. No.
A - contd.	
Asdic - contd.	
Sets in H.M.A. Frigates and H.M.A.S. "Orara" and "Kybra"	†185/44
Stores - Packages Containing - Marking	†98/44
Ashes and Garbage from H.M.A. Ships at Outer Harbour and Port	
Adelaide, Disposal of	513/45
Assessment of Efficiency	240/44
Atebrin - Suppressive Treatment (Prophylaxis) for Malaria ..	432/45
Attache Cases - Restriction in the use of	73/45
Attacks by Surface Craft on Enemy Submarines	391/44
Aural Care and Selection of Submarine Detector Ratings ..	47/44
Australian Defence Canteens Service Clubs	640/45
Military Forces - Flag of Water Transport Units of	755/45
Naval Liaison Officer, Noumea	544/44
Red Cross Society	
Authorities under National Security Regulations -	
Administration of Oaths etc. to Members of Certain Forces ..	522/45
Entry to Enclosed Wharves	495/45
Protection of Shipping (Accommodation for Defence Personnel)	
Order	614/45
Authorised Allowances of Accessories (Test Equipment) for	
Australian Type Radar	†140/44
Kits - Uniform and Clothing - Royal Australian Naval	
Women's Services	375/45
Automatic Morse Operators and T/P Visual Signallers, Coders -	
W.R.A.N.S. - Advancement	20, 55, 128, 204, 44
Auxiliary Minesweeping Vessels Fitted with D.G. and S.A.	
Equipment - Voltage Regulation in	†14/45
Vessels - Naval Armament Store Accounts of	73/45
Store Accounts	479/45
War Vessels - Magazine Logs	221/45
Awards, Decorations and Honours to Naval Personnel	12, 85, 211, 355/45; 200/44
Awings, etc. - Landings of - A.M.S. Vessels	561/45

B

Badge Special for Bomb Disposal Squad	17/45
Badges - Controlled and Observation Mining Ratings	96/45; 7/44
- D.E.M.S. Gunnery Ratings	95, 358/44
- for W.R.A.N.S. Ratings	95/45
- Flying	647/45
- Good Conduct	486/45
- Service, R.A.N.R. - Deprivation and Restoration ..	61/44
- Metal Cap for Chief Petty Officers and Petty Officers	254/45
- Officers' Cap	45, 244/45
Ball Ammunition .303" : Replenishment from Army Stocks at ..	202/45
Outports and Roller Bearings - Procurement	4/44
Ballast - Carriage of Shale or Colliery Refuse in Ships carrying	
Explosives	158/45
Band Instruments - Ceremonial - Naval Reserve Depots	409/45
- Orchestral - Percentage Charge and Grants-in-Aid ..	197/44
Bank Agencies - Commonwealth Savings - Commission	85/44
"Basegram" and "Deferred" Prefixes - Need for greater use of ..	†2/45
Base Spares - Propellers and Tailshafts	371/44
Batteries - Low Power - Mounting on Resilient Mountings in Order	
to Reduce Effects of Shock	†252/44
- Main Low Power - Increased Capacity	†276/44
Battle Dress	131, 285/45

† Denotes C.C.N.O.

Subject	C.N.O. or C.C.N.O. No.
B - contd.	
Beacon(s) - Radar	†141/44
- Euston Reef - Radar Reflector	†119/44
Beckets - Reeving of - Clips Cartridge No.25	164/44
Bed Linen - Clothes Rationing	185/44
Bedding for W.R.A.N.S.	169, 218, 386/44
Issued to Chief Petty Officers, Petty Officers and	
W.R.A.N.S. - Naval Store Accounting Procedure in H.M.A.	
Shore Establishments	506/45
- Wartime Allowances - R.A.N. Shore Establishments	469/44
Belts and Swords for Masters-at-Arms	346/45
- Waterproof Coats	298/45
Bicycles - Losses of	426/45
- Departmental - Branding of	611/45
Bigamous Marriages, Prevention of	274/45
Bilges - Pitting in Engine Room - A.M.S. Vessels	†69/44
Bills - Quarter - Amendments	189/44
Binoculars - for D.E.M.S.	252/44
- Pattern 1900A	35/45
- Telescopes, Watches and Heliographs - Muster of	397, 595/44
- Temporary Reduction in Full Approved Scales of	
Allowances	425/45
"Bishopdale" R.F.A. - Fitted for Oiling at Sea by British Buoyant	
Hose Method	†71/45
Blankets and Mess Gear - Issue to Personnel travelling ..170, 284, 352, 627/44	
- Duffel Coats and Towels for Survivors	300/45
- for Loan Issue - Prices for Losses by Neglect	59/45
- Officers' (Naval Stores) Lost by Neglect - Charges for	252/45
Bleaching Powder for H.M.A. Naval Establishments under conditions	
of actual Gas Warfare in Australia	†165/45
Blooms - Steel and Wood	312/45
Blue Caps for Ratings	191/45
Trousers - Alternative types	37/45
Bluette Combination Suits - Loan Issue of - N.A.P.	56/45
Board of Trade Certificates - R.A.N. Officers	308/45
Bofors - Guns - Care and Maintenance	165/44
H.E. Ammunition - Cartridges 40 m.m. - Fitted with	
Primers No.18 - Withdrawal - Report	580/44
O.Q.P. 40 m.m. - E.F.C. Valves	378/44
- Liquid in Recoil Buffers	375/44
- Looking of Screws, Securing Bracket	
Supporting Buffer - Fitting of Shock-	
proof Washers	466/44
40 m.m. - Ammunition - Policy in regard to issue	653/44
Mk.I and I* (Naval) Aust. Manufacture	486, 577/44
- Modification - Breech Casing	
right front	429/44
- Cartridge Deflector	451/44
- Left Rear of Breech Casing	453/44
- Safety Lever Indicator	452/44
Mk.IIIA Gun Mountings - Slewing Handles to be	
fitted	450/44
Boiler Feed Water - Contamination of by Oil Fuel - A.M.S. Vessels	275/44
Tube Cleaning Apparatus - Flexible Shafting for	15/45
Boilers - Combustion Cones for - Permanent Naval Stores	91/44
- Water Tube - Use of Shore Water for	†161/44
Bolts Gunmounting - Holding down	184/45
Bomb Disposal Squads - Special Badge	17/45
Bombs and Mines, Disposal Work - First Aid Precautions	686/44
Rendering Safe - Organisation round the Australian	
Coast	187, 240, 276, 309, 617/45

† Denotes C.C.N.O.

Subject	C.N.O. or C.C.N.O. No.
B - contd.	
Books and Forms	19, 29, 38, 61, 82, 100, 208, 260, 302, 318, 350, 373, 408, 434, 478, 510, 566, 650/43; 55, 78, 102, 129, 185, 198, 247, 268, 299, 341, 358, 359, 388, 422, 470, 481, 511, 523, 554, 573, 602, 616/44
- Local Secret and Confidential - (See Local Secret and Confidential Books)	
- Ships' Library - Purchase Price Limit ..	225/45
- Supply to Small Ships ..	207/45
Boom Defence Depots - Darwin, Fremantle, Sydney and Brisbane ..	277/45
- Establishments of, at Cairns, Townsville, Port Kembla and Port Moresby ..	58/44
Working Vessels and Gate Vessels - Additional Armament ..	757/45
Bore Telescopes for Q.F. 4" Mark XIX Guns ..	269/45
Boots - Football	550/45
Amended Issuing Price	536/44
- Rubber Sea - Oilskin Clothing - Storage of ..	550/45; 245/44
Boxes Ammunition C.222 and C.199	2,278, 416/44
Complete Tools and Spare Parts, Marks IV and IV** Pistols -	
Boxes Complete Testing Sets, Marks IV and IV** Pistols	45/45
For Gas Cylinders	619/45
Magnetic Compasses - Return when empty ..	454/45
B.R. and O.U. Books Account	600/44
274/41 - Handbook and Drill for 20 m.m. Oerlikon Gun -	
Amendments to Drill	371/45
637 - Mersigs Vol. I	535/45
797 - Handbook on Lookouts and Service Optical Instruments -	
1945 - Amendments	340/44
Branch-Coding	359/45; 16/44
- Pass Professional Examination	60/44
Special - R.A.N.V.R.	224/45
Branches - Ordnance and Electrical Mechanic	82/44
Branding of Departmental Bicycles	611/45
Bread - Supply of, at Melbourne	551/45
Breech Mechanism - Modification to O.Q.F. 4'7" Mk. XII, XII* and XIIB	579/44
Bren Machine Guns - .303" Mark I - Springs, Return Mark II ..	185/45
Bridge Chart Table Modification to - Escort Vessels fitted with Radar	1134/44
Bright Steel Bolts, Nuts and Studs, manufactured from Marbrite Free	
Cutting Steel	594/44
Bristles, Economy in - Care of Paint Brushes	548/45
the use of - Discontinuance of Purchase of Pattern C.280 and C.281 Sash Tool Brushes during Hostilities	658/45
British - U.S. Communications - Flags	557/45
Broadcast Receivers - Commercial Types	615/44
B.S. and R.M.S. Equipment - Afloat	715/45
- Organization - Confidential Outfits of Tools	727/45
Burials, Graves, Registration, Identification of Bodies and Burial of Enemy Dead	15/45
Burnett Prize	411/45
Burning of Oil Fuel	295/45
Burns - X-ray - Prevention	456/45
"Burrabra" H.M.A. - Paying off	7127/44
Business Member - Naval Board of Administration	21/45; 105/44
Butter, Concentrated, Hardened - Replacing Butter Fat Spread ..	565/44
- Economy in Consumption of	115/44
Butts for .303" Vickers Machine Guns on Single A.A. Mounting ..	477/44

† Denotes C.C.N.O.

Subject	C.N.O. or C.C.N.O. No.
C	
C.A.F.O. 2563/42 - Reduction of Fire and Smoke Risks in H.M.A.	
Ships - Application in the R.A.N.	745/45
Cameras - Use in Northern Territory and other Advanced Bases -	
Control of Photography	25,456/45
Camouflage and External Painting - Standardization of Colour	
Shades and Introduction of A1 and A2 Class Qualities Paint ..	400/45
Candidates for Examination for Higher Ratings in the Sick Berth	
Branch	64/45
Canned Meats - Warranty period for	567/45; 68, 255/44
Cans for Meat Packs - Embossing of	174/45
Canteen and Mess Stocks - Insurance of	140/45
Arrangements in R.A.N. - Revised - and Establishment of an R.A.N. Central Canteen Fund	484/44
Funds - Accounting for Articles purchased	649/45
Stores for H.M.A. Ships	153/45
Canteens - Australian Army - Issuing Points	599/44
- Naval - Chocolate and Confectionery for	596/45
- Sale of Proprietary Medicines in	529/45
- Service System in Frigates and A.M.S. Vessels ..	446/44
- Administration of, in H.M.A. Ships and Establishments where no Accountant Officer is borne	618/44
Stores - Supply of	285/44
- Supplies of Citric Acid for	281/45
Canvas Flag Wallet for A.M.S. Vessels	114/44
Hose Gaiters to prevent chafing	193/45
Tubing - Prolonging life	92/44
Cap Badge(s) - Metal, for Chief Petty Officers and Officers ..	254/45
- Officers'	244/45
- Ribbons	299/45
Caps - Blue for Officers and Men proceeding to the United Kingdom	
Ratings	46/44
Captain of Heads Allowance	191/45
Carbon Paper and Typewriter Ribbons	258/44
Cards, Signal - A.B.R. 252 - Issue to Ordinary Seamen, V/S ..	427/45
Care and Maintenance of Bofors Guns	288/45
- 20 m.m.	165/45
of Stores	121/45
Carriage of Shale or Colliery Refuse as Ballast in Ships carrying Explosives	282/45
Carriers - Ammunition, Double, for O.Q.F. 4" Mk. XIX and O.Q.F. 4" Mk. XVI*	
- Quadruple, Ammunition and Carriers, Shell Quadruple - Transfer to Gunmounting Department	158/45
Cars - Allowance for Use of Private Motor	328/44
Cartridges - Cases - Q.F. 4" XVI* Gun - Withdrawal	182/45
- Repair of	277/45
- Marking of, with Sub-Lot XJ	44/44
- M.L. 9.5 in D.C.T. Cordite H.S.C.T. 154-055, 4-oz. 0 drms. Mk. XII - Intro- duction of	150/45
124/058, 3-oz. 14 drms. Mk. II - Withdrawal	54/44
- Q.F. 2-Pdr. H.V. Mark VIII Gun H.E. Mark X.L. Filled	
Glascod 8/41 and 9/41 - Restricted	73/44
- S.A., Ball 9 m.m. of D.I.L. manufacture - Restriction	63/44
.303" Land Service	35/45
.435" Ball, Revolver - Mark II Cartridges to be re- placed by Mark VI	95/44
	250/45
	181/45

† Denotes C.C.N.O.

Subject	C.N.O. or C.C.N.O. No.
C - contd.	
Cartridges - contd.	
- Signal 1" Red or M.E. 1942 Manufacture : To be landed	74/45
With Sub-Lot XJ - Marking of	141/45
- 40 m.m. Bofors H.E. fitted with Primers No.18 - Withdrawal - Reports	580/44
Case Markings - Shipment of Mining Stores	216/44
Cases - Cartridge - Repair of	150/45
of Sea Sickness - Medical Surveys on	†137/45
- Packages etc. for Port Moresby, Marking of	520/45
Cash Advances to Fighting French Warships	†75/44
H.M.A. Ships from U.S. Ships	303,873/44
Vouchers and Forms - Captain's Signature	150/44
Categories - Drafting	90/45
Cells - L.L. 57/5 - For L.L. Sweeps - A.M.S. Vessels	†8/44
Censorship - Naval	23,98,177/44
Census - Annual - Office Machinery	22/44
Ceremonial Band Instruments - Naval Reserve Depots	409/45
Certificates - Board of Trade, R.A.N. Officers	306/45
† Disposal of, on Reversion - R.N. Ratings on Loan to the R.A.N.	190/44
- Naval Watchkeeping - Naval Reserve Officers	256,319/44
- P.M.G. - Examination for - Eligibility of Telegraphist Ratings for Exemption in certain subjects	75/44
- Service and Pay Accounts - H.M.A. Ships attached to Eastern Fleet	57/44
Change of Address - Directorate of Medical Services of Netherlands East Indies	584/45
Class of Uniform - Outfit Gratuities on	548/45
Name - Channel Patrol Boat "Egeria"	256/45
- H.M.A.S. "June"	517/45
Channel Patrol Boat "Egeria" - Change of Name	256/45
Chapel Equipment	680/45
Charge - Transfer of, between storekeeping officers, Naval Store Accounts	251/45
Charges for Blankets lost by neglect	59/45
Officers' (Naval Stores)	252/45
Reduced - use of, for Practice - Q.F. 4" Mks.XVI - XVI* Guns	†80/45
Charter - Stores remaining on requisitioned vessels on termination of	574/45
Chart Folios - Establishment in H.M.A. Ships	†190/44
Charts - Admiralty - Correction of - in H.M.A. Ships	101/45
Chemical Warfare Training	361/45
Chests - Labelling and Marking of	57/45
- Steel, for A.M.S. Vessels	182/44
Custody of Confidential Books in Fairmiles	†21/45
Chevrons for War Service	219/44
- Issue of - Summer Uniform - Naval Dockyard Police	190/45
Chief Petty Officer - Advancement to - R.A.N.R. Petty Officers	290/44
Shipwright - Advancement to - Qualification	522/44
China, Earthenware, and Glassware - Shortage of Supplies	532/45
Chocolate and Confectionery for Naval Canteens	596/45; 408/44
and Messes	158/44
- Condemnation of	175/45
Cholera - Innoculation Against	†149/44
Christmas and New Year Greetings	604/45
Chutes - Hand-up for 4" Ammunition - Modification	†180/44
Cinematograph Projectors	636/45
Circulating Water Systems in Fairmiles Motor Launches - Modifications to	526/45

† Denotes C.C.N.O.

Subject	C.N.O. or C.C.N.O. No.
C - contd.	
Citric Acid for Canteens, Supplies of	281/45
Civil Gaols, Subsistence of persons in	227/45
Claim Forms for Compensation - for Total Loss of Uniform Clothing - Ratings - Introduction of Forms A.S.105Y and A.S.105Z	242/44
Classes and Examination for Seaman Petty Officer and Leading Seaman	215,305,655/45
Classification of Night Vision by A.R.L., Adaptometer (Mark III) - Security	545/44
Cleaning Gear, Economy in the use of	†203,411/44
Clearing Charges - Ammunition - 20 m.m. Cerlikon	295/45
Clips Cartridge No.25 - Reeving of Beokets	151/44
- No.1 Mark I	184/44
- Inglefield and Unservicable Flags - Return to Store	359/44
Cloak Room - Military - Adelaide Railway Station	69/44
Close Range Weapons and Small Arms - Precautions	515/45
Clothes Rationing	467/45
Clothing - Additional Tropical Khaki - Supply to Ratings serving in Northern Areas	650/44
and Uniform - Issues of on repayment to Personnel of Allied Navies	624/45
- Royal Australian Naval Women's Services - Authorized Kits	369/45
- Gymnastic Shoes	375/45
- Supplies	19/44
Articles and Uniform - Ratings - Compensation for Loss of or Damage to	189,464/45
- Asbestos for Fire-fighting	204/45
- Civilian - Supply of, to Members of the Naval Forces on Discharge	621/45
- Issue of Loan Protective Clothing to Gunners of Maritime Troop, Royal Artillery	214/44
Issued on Repayment - Form A.S.1048 - Daily abstract of	389/45
- Issues of, to Survivors	156/45
- Special - for Personnel in Forward Island Areas	329/45
495/44	224,282,
- Khaki, Tropical	402/45
- R.A.N. Auxiliary Service Ratings	461/45
Maintained for Issue on Repayment to Ships' Companies - Amendment to Official Memorandum	51/44
- Oilskin Anti-Gas - Upkeep and Repair	21/44
and Rubber Sea Boots - Storage of	550/45; 245/44
- Prices of - Maintained for Issue on Repayment to Ships' Companies - Official Memorandum	285/44
- Protective	251/44
for Fire and Repair Parties	280/45
- Loan - for Boom Depots	549/45
- Rationing - Bed Linen	185/44
- Repayment - in Tenders	492/44
- Special - for Mosquito and Sand Fly Infested Areas	168/45
Issues for Personnel in Forward Island Areas	625/45
to D.E.M.S. Ratings - Lifesaving Waistcoats and Torches	505/45
- Supplies and Uniform - Repayment Issues of Materials	171/44
- Supply of Civilian Clothing to Members of the Naval Forces on Discharge	390/45
- Tropical	171/45

† Denotes C.C.N.O.

Subject	C.N.O. or C.C.N.O. No.
C - contd. - *	
Clubs - Australian Defence Canteens Service	47/44
Coal for H.M.A. Ships - Procedure governing supplies	32/44
Coastal Craft - Fire Precautions	70/44
Section - Formation	652/44
Coats, Waterproof - Belts	298/45
Code - Ammunition etc. - for Signalling requirements	†275/44
and Cypher Machines - Installation in H.M.A. Ships	†112,†288/44
Coder's History Sheet - Form A.S.1248 V	627/45
Coders, Visual Signallers, T/P and Automatic Morse Operators, W.R.A.N.S. - Advancement	204/44
Coding Branch	359/45
- Pass Professional Examination	60/44
- Re-examination for Ordinary Coder	16/44
Machines and Spare Parts - Transport of	†24/44
Coil, Sisal and Manila Cordage	504/45
Cold Room - Refrigerating Plant for A.M.S. Vessels	210/44
Combination Suits - One and Two Piece - Cutting of Sleeves	370/45
Combined Operations - Advancement of Ratings Trained in Section - Senior Naval Officer	649/44
Combustion Cones for Boilers - Permanent Naval Stores	515/44
Comforts forwarded to H.M.A. Ships and Establishments - Acknowledgement of	91/44
- War	606/44
Command - Naval - New Guinea Area	525/45
Commander-in-Chief, Eastern Fleet - Address of	†67/45
Commercial Type Pyrotechnics Landed from Requisitioned Ships	†90/45
Commission - Commonwealth Savings Bank Agencies	588/45
- Ships not in	85/44
- Ships not in	†1/45
Commissioning of H.M.A. Ships, etc., (see H.M.A.S.)	
Commissions - Temporary - Accountant Branch Ratings	366/44
- Coder Ratings	414/44
- Selection of Ratings from Lower Deck	105/45;474/44
Committees Welfare	247/45
Commonwealth Legal Service Bureaux	629/44
Reconstruction Training Scheme	670/44
Savings Bank - Agencies	85/44
Communicable Diseases - Introduction to New Guinea and Australia	†234/44
Communications - Branch - Advancement	105/45
- British - U.S. - Flag	557/45
- Depth Charge	†21/44
with the Press	153/44
Compass Equipment - Sperry, Commercial Gyro - Maintenance	†31/45
(Gyro) Mark XIV - Instructions - Mod.I Oiling Chart, Item 15	398/45
- Magnetic - Effect of Telephones on	553/44
- Sperry Mk.XIV Mod.I Gyro - Incorrect Fitting of Trans- mitter Connecting Cables	514/44
Compassionate Drafts	†280/44
Compensation for Loss of or Damage to Uniform and Clothing	
Articles Tools	184/44
Total loss of Uniform and Clothing - Officers and Ratings	561/44
Components - A/S - Defective	502/45
of Admiralty Type Radar	†282/44
Compulsory making of Wills	47/45;220/44
Concession Fares - Victorian Railways, on Suburban Lines and to and from certain Country Stations - N.A.P.	14/45
Messages - to and from Naval Personnel	514/45
Railway Fares of Service Personnel Travelling in Uniform and Paying their own fares	645/44
Travel - for Members of the Forces - in N.S.W.	50/45;555/44
† Denotes C.C.N.O.	

Subject	C.N.O. or C.C.N.O. No.
C - contd.	
Concession - contd.	
- Warrants - Leave Travelling - Issue of	275/45
Condemnation of Chocolate	175/45
Condemned, Unserviceable etc. Stores - Salvage of - Army Salvage Service	267/44
Condition of Stores and Equipment returned to Victualling Yards	167/45
Confidential Admiralty Fleet Orders and Admiralty Fleet Orders and Secret Correspondence - Security	178/45
Books in Fairmiles - Steel Chests for Custody of	†99/44
- Instructions for the Accounting, Custody, etc.of	†21/45
Commonwealth Navy Orders - Issue of	†170/45
Correspondence - Registration	196/45
Messages - Transmission in Plain Language over Tele- printer Channels	300/44
Navy Orders - Issue of	98,155/44
Reports on Naval Reserve Officers	†1/44
Confirmation and Promotion of Naval Reserve Officers	360/45;257,427/44
Provisional Promotion for R.A.N.R. and R.A.N.V.R. Officers in time of war	501/44
Qualifications for Stoker Petty Officer - Acting Leading Stokers	538/45;681/44
Conjugal State of Service Personnel - Disclosure of information regarding	518/45
Conservation of Tyres and Tubes	542/45
Consignments of Victualling Stores delivered in H.M.A. Ships in a deficient or damaged condition - Accounting for	279/45
Consulting Oral Specialist to the R.A.N.	256/45
Consumable Naval Store(s) in Merchant Vessels Commissioned for Naval Service - Accounting for	161/45
- Issue of, to H.M.A. Motor Patrol Boats and Small Vessels in which Accounts of Con- sumable Naval Stores are not required to be maintained	366/45
Ledger Sheets - Amendment of Form A.S.151	575/45
- Naval Armament Stores Accounts - H.M.A. Ships, etc.	246/44
Consumption of Butter - Economy	585/44
Containers - Anti-Gas Respirators	115/44
Contract(s) at Adelaide - Ratings' Made-to-Measure Uniforms	†145/45
Prices, Reduction in - Alteration to Jackets of Petty Officers and Men not dressed, as Seamen	257/45
Rates - Fresh Provisions - At Melbourne	264/45
- At Sydney	194/45;101/44
Supply of Ratings' Made-to-Measure Uniforms	194,556/45
by private outfitters at Hobart	405,308/44
Perth	115/45
Sydney and Melbourne	116/45
W.R.A.N.S. Ratings' Made-to-Measure Jackets and Skirts	59,114/45
Continuation of Allotments of Members of the R.A.N. who are reported Killed, Missing - Presumed Killed, Missing or Prisoners of War	406,628/44
Control Gear and Electrical Switch - Mounting on Resilient Mountings to reduce effects of shock	199/45
of Photography - Cameras - Use in Northern Territory and other Advanced Bases	†242/44
Venereal Disease - Melbourne Area	456/45
- Prophylactic Centres	†40/44
Controlled and Observation Mining Ratings - Badges	†132/44
Convalescent Home for Women's Services	96/45;7/44
Leave Prior to Discharge - "Invalided" from R.A.N.	284/44
.. ..	440/45
† Denotes C.C.N.O.	

Subject	C.N.O. or C.C.N.O. No.
C - contd.	
Convoy Escort Organization	†121/45;†51/44
Plotting Board	†251/44
Protection - Liaison between Naval and Air Force	
Officers engaged on	599/45
Signal Ratings	48/45;584/44
Cooks - Officers' and Ships' - Special Issue of Boots to	460/45
- W.R.A.N.S. - Galley Shoes for	77/44
Cordage - Coir, Sisal and Manilla	504/45
Cardite Isending	26/45;90,180/44
- Quarterly Return of Temperatures of - Form S.1147/	
Non-rendering	†101/45;†100/44
Records - Maintenance on Board H.M.A. Ships	89/44
Correction(s) of Admiralty Charts in H.M.A. Ships	101/45;490/44
to Local Secret, Confidential and O.U. Books	†170,†182,†189,†200, †215,†255,†285/44
Correspondence and Mails for N.O.I.C., Hobart	562/45
Courses - at Sydney and Melbourne Technical	
Colleges	146/45
- Vocational Training during War	540/45
- H.M.A. Radar School	441/44
- London	604/44
on Naval Armament Store Matters - Naval Officer-	
in-Charge, Brisbane	174/44
Orderlies and Postmen	259/44
- Secret and Confidential - Instructions re-	
acknowledgment, custody, disposal, etc.	†56/44
Corrigendum to Navy Order	96/45
26 of 1945	119/45
69 of 1945	†107/45
84 of 1945	157/45
105 of 1945	209/45
144 of 1945	262/45
168 of 1945	354/45
215 of 1945	503/45
248 of 1945	410/45
560 of 1945	567/45
404 of 1945	465/45
411 of 1945	515/45
458 of 1945	226/44
528 of 1945	96/44
24 of 1944	151/44
54 of 1944	105/44
66 of 1944	116/44
71 of 1944	218/44
169 of 1944	589/44
266 of 1944	465/44
412 of 1944	574/44
525 of 1944	†42/45
Corvettes, "River" Class - Reclassified as Frigates	245/44
Cots - Stretcher - Pattern 474 - Supply	†120/44
Counter - Measures to Acoustic Homing Torpedo - F.X.R. Gear	
Counterpanes, Coverlets and Mattress Covers - Return to Store of	
Numbers held in Excess of Allowance	598/44
Coupons - Food - Naval Personnel	266,605/44
Course and Examination for Chief Ordnance Artificer	451/44
Courses - Navigation	59/44
Cremation of Deceased Service Personnel	325/44
Crystal Control - W/T Transmitters Fitted for - A.W.A. Type	104/45
Cuff Lacing Worn by Lieutenant-Commanders R.A.N.R. and R.A.N.V.R. -	
Uniform	127/45

† Denotes C.C.N.O.

Subject	C.N.O. or C.C.N.O. No.
C - contd.	
"Current Affairs Bulletin" and Journal "Salt"	155/45
Custody of Keys of Safes and Chests in Small Ships	†52/44
Naval Stores	151/45
C.W.I. Forms - Forwarding of	79/45
Cylinder Liquid - Test of Recoil - Gun Mountings	192/44
Cylinders - Gas - Contractors - Return of	99/44
- Empty - Return of	48/44
For Engineering and Medical Purposes - Marking	254/45
Industrial Gases	262/44
Medical Purposes	528/45
- Water Pressure Test	289/45;295/44
Cypher and Signal Logs - Disposal of	†44/44
D	
Daily Abstract of Clothing issued on repayment - Form AS.1048	156/45
Damage or loss of Uniform and Clothing Articles - Compensation	
for - Rations	204/45
to Mail received at Milne Bay	457/44
Railway Property and Accidents sustained by Members of	
the Services - Personnel travelling by train	200/45
Dark Adaptation - Night Vision - Supply of Dark Adapting Goggles	†164/45
Darwin and Thursday Island - Period of Shore Service at	680/44
Naval Armament Depot	146,†212/44
Base Organization	197,†112/45
Hospital	52/45
Dating of Passing Professional Examination for Higher Rating	179/45
D.C.Pistols - Expenditure Six Monthly Ending 30th June, 1945 -	
Analysis	†79/45
- Fitted Diaphragms, I.R. St. No.6067 - Test of "Safe"	
Positions	419/45
- (M) Type B-B* - Introduction of Klingerite Washers	441/45
Deafness due to Gunfire - Recording in Medical Officer's journals	672/44
Deaths - Information to be forwarded where personnel die from	
disease or injury	229/44
Deceased Personnel - Letters found amongst effects of	56/44
Service Personnel - cremation of	525/44
Deck Log and Ship's Log - Instructions for compiling	557/45
Decorations, Awards and Honours	12,85,211/45
"De Facto" Wife - Change of Term	490/45
Defective A/S Components	502/45
Defences - Seaward - Addresses	†22,†60,†110, †150/45;†156/44
"Deferred" and "Basegram" Prefixes - Need for greater use of	2/45
Pay	†167/45
of Mobilized personnel	27/44
on Transfer of another arm of the services	225/45
Defensively equipped merchant ships - Paravane towing ropes	6/45
Dehydrated vegetables	175/45
Delegation of Authority - Supply of Spectacles	297/44
Powers -	
National Security (General) Regulations -	
Control of Lighthouses, Buoys, Beacons, etc. (Reg.46)	556/45
Traffic at Ports (Reg.64)	556/45
General Control of Navigation (Reg.45)	556/45
Handling and Conveyance of Ammunition in Ports (Reg.66)	556/45
Immobilization of Vessels (Reg.45D)	556/45

† Denotes C.C.N.O.

Delegation of Powers - contd.	
National Security (General) Regulations - contd.	
Measures for safety of Australian Ships (Reg.47)	536/45
Navigation Order (Reg.45)	536/45
Power to arrest and hold in custody certain seamen	536/45
Prohibited Places (Reg.4)	536/45
Restrictions on departure of ships (Reg.45B)	536/45
Stoppage of ships (Reg.24)	536/45
Demands for Naval Stores	655/45
Replenishment of Naval Stores	99/45
Victualling Stores - Economy in use of forms	255/45
Demolition Stores - Electrical - Withdrawal of	571/44
D.E.M.S. - Binoculars for	252/44
- Gunnery Equipment - Painting of	350/44
Ratings - Badges	95,358/44
- Issue of Loan Protective Clothing to Gunners of Maritime Troop, Royal Artillery	368,389/45
Whistles and Lanyards	657/45
- Oerlikon Ammunition Outfits for	756/45
- Personnel - Liability for pay, etc.	159/45
- Ratings, Drafting records, etc.	320/44
D.E.M. Ships and Small Ships - Handling Explosives in	397/45
- Ratings recommended for service in	65/45
Dental and Medical facilities in the New Guinea Area - R.A.N.	7272/44
Work - Quarterly return of	655/44
Dentures and Spectacles - loss through active service	347/45
Dependant Allowance - Payment of - "Dependent Female" (formerly termed "De Facto" Wife)	668/45
Dependants of Members of the Forces who have married abroad - Passages to Australia for	600/45;392/44
Depth Charge(s) and Associated Stores - Weekly Stock Reports	72,7155/44
at Australian Ports and in Armament Store	
Issuing Ships - Reserves of	757,766/45
Chutes - Modification to Method of Securing to Deck - Motor Launches	716/44
- Repositioning - M.Ls.	152,7184/44
Communications	721/44
- Dummy - for exercise purposes	711/45
Equipment - Modification of Depth Charge Rails and Templates	7125,620/45
Expenditure, six months ending 31st December	
1942 - Analysis	78/45
1943 - Analysis	742/44
30th June - Analysis	7181/44
Mark VII - VII* Filled Minol	7106/44
- Minimum Speeds for firing Depth Charge Patterns	7188/44
- Minol filled - Allocation of	7277/44
Pattern Control - Introduction - Alterations and Additions	121/44
Patterns - Minimum Speeds for firing	188/44
Pistols - Diaphragms I.R. St.No.6067 - Precautions	267/45
- "Half Cock" Position	7145/45
- History Sheets	54/45
and Keys, Depth Adjuster - Disposal	149/45
- Details required	145/44
- Form 0426	94/44
- Mark VII - IX - Locking Screws	124/45
- VII* Reg.No.4614	684/44
- VIII* - Distribution	712/45
- VIII*	710/45

† Denotes C.C.N.O.

Depth Charge(s) - Pistols - Mark VIII* - contd.	
- Distinguishing Markings	35/45
- Modification for Marks XIII A and XIII* - Apparatus Testing Adjuster	545/45
- Restrictions on issue	415/44
- Routine Tests	421/45
- Plugs Wood, Primer - Tube Stamp No.6053	165/44
- Practice Expenditure	7122/44
- Precautions in Hot Climates	73/45
- Preservation of Markings	605/45
- Thrower Mk.II Pistols M.L. 9.5" - use of	
- Correct Description	552/44
Pistols - Spares	65/44
(A.F.O.1954/45)	501/45
Throwers - Firing Trials - Ships fitted with Four Throwers	7126/45
- H.M.A.Ships - Position, Angling and Clearances from Ship's side	7116/45
- Mark II - Replacement	725/44
- Mark IV - Securing Strap - Supply of Spare Wire Spans	581/44
- Traps - Modification to Check Pawls	560/45
Type (M) and Depth Charges Mark VIII - Defective Bungs Charge Case	196/44
- Use of, in Shallow Waters	7261/44
With Split Charge Cases - Reports required	182/45
Deserters and Absentees - Warrants of Arrest for	451/45
- Recovered - Advancement of	26/44
Despatch of Naval Armament, Gurmouting and Torpedo Stores to Melbourne	420/45;45/44
Personnel to Ships and Establishments in New Guinea Area	450/44
Sydney for Medical Observation or treatment not requiring Hospitalisation	258/44
Destroyers and A.M.S. attached to Eastern Fleet	415/44
Detention Barracks - Military - Uniform and Clothing of Ratings in or Imprisonment - Disposal of Ratings after Sentence	556/44
- Personnel sentenced to	250/45
- Quarters - Sydney	5/45
- Quarters - Sydney	487/45
Deterioration of Cast Iron Condenser Doors - A.M.S. Vessels	11/44
Detonators - No.25, Mark I Lot 53, Filled M.E.8/41	292/45
- Withdrawal of	98/45;100/44
- Percussion, Watertight, Mark VI and VIA	16/45
VII Lot 141 B.R.8/41 - Withdrawal	41/44
D/F Equipment A.W.A. Type C.145A - Fitting of - Alteration and Addition - A.M.S. Vessels	785/45
D.G. Permanent - Installation of, on A.M.S. Vessels	82/45
Diagonal Serge	352,565/45
Diaphragms I.R. - to be fitted to Depth Charge Pistols	29/44
Dies, Stocks and Taps - Adoption of Commercial Type for use in H.M.A.Ships and Establishments	367/45
Difference in Pay to Ratings performing Higher Duties - Naval Financial Regulations and Instructions, Article 74 of Pay - Electrical Artificers, Ordnance Artificers and Shipwrights	365/45
Directing Gear - A/S Sets Type 128	248/45
and 144 Series	784/45
.. .. .	7185/44
Direction(s) for Principal Naval Overseers, Overseers and Inspecting Officers	369/45
Under the Wireless Stations Control Order	210/45
† Denotes C.C.N.O.	

Subject	G.N.O. or C.C.N.O. No.
D - contd.	
Directorate of Medical Services of Netherlands East Indies	
Forces - Change of Address	584/45
Discharge - Applications from Naval Personnel for	205/44
from R.A.N. on Account of Physical Unfitness for	
Service	95/45
- Retention of kit on	549/45
Discharged Naval Personnel - Rehabilitation Procedure for	14/44
Discharges to Hospitals Abroad	585/45
Disclosing of information regarding conjugal state of service	
personnel	542/45
- service matters	307/45
Discontinuance of supply of certain items - Mess gear	10,66/45
Discrepancies in Stores Shipped Reports A.D.690 and O.9	51,560/44
Disease - Communicable - Introduction of in New Guinea and	
Australia	†254/44
Disposal of Cypher and Signal Loss	†44/44
Mines rendered safe	251/44
by R.M.S. parties	164/45
Obsolete and Unserviceable Films - Instructional Films	296/44
Ratings after sentence of detention or imprisonment	250/45
Unserviceable American ammunition	†78/44
Divers - Selection of Ratings for	149/44
Diving Equipment	†115/45; †105/44
Non-Substantive Rating	365/44
Dockyard Police Naval - Summer Uniform - Issue of Chevrons	190/45
Domes A/S - Losses of, and Damage to	†18/45
Draft - Medical Examination prior to	120/44
Orders and Instructions	541/45
Drafts - Compassionate	†280/44
Drafting, Categories	90/45
and personnel found medically unfit	24/45
of Personnel - Malaria Control	118/44
- W.R.A.N.S.	159/44
Dragnets - Allowance	511/45
Drawing and Painting Schools, Victoria	158/45
Dress, Battle	151,265/45
Officers'	†50/44
Drill - Amendments to - B.R.274/41 - Handbook and Drill for 20 m.m.	
Oerlikon Machine Gun	371/45
Tunics with Blue Facings	71/44
Drogues and Kites for Anti-Aircraft Targets - Discontinuance of	
Supply	146/44
Drydocking H.M.A. Ships - Precautions to be observed to prevent	
damage to Radio Gear, etc.	325/45
Duffel Coats, Blankets and Towels for Survivors	300/45
Dummy Depth Charge for Exercise purposes	†11/45
Duplicate Keys, etc.	†41/45
Duplicators - Spirit - Use of Methylated Spirit	407/45
Duty Free Articles for H.M.A. Seagoing Ships	28/45

E

Earthenware, China and Glassware - Shortage of supplies	552/45
Plates	81/45
Eastern Fleet - Address of the Commander-in-Chief	†90/45
- H.M.A. Ships attached to - Service Certificates and	
Pay Accounts	57/44
Echo Sounding Equipment - Periodical Material Reports	†16/45

† Denotes C.C.N.O.

Subject	G.N.O. or C.C.N.O. No.
E - contd.	
Economy in Bristles - Care of Paint Brushes	348/45
Consumption of Butter	115/44
Expenditure	398/45
the use of Bristle - discontinuance of purchase of	
pattern C.280 and C.281 Lash Tool Brushes during	
hostilities	658/45
Cleaning Gear	295/45
Coal, Coke, Gas and Electricity	608/45
Cordage and Coir Fenders - "Apple-ring" Type Fenders -	
Manufacture of	654/45
Education and Vocational Training - Director	619/44
Educational Service - R.A.N. - Reconstruction Training Scheme	324/44
Test 1 - Results - December 1942	71/45
- March 1943	272/45
- June 1943	468/45
- September 1943	81/44
- December 1943	203/44
- March 1944	318/44
- June 1944	475/44
- September 1944	668/44
- Higher - R.A.N. - Results - October 1942	104/45
- April 1945	558/45
- October 1945	156,248/44
- April 1944	459/44
Efficiency - Assessment of	120/45
of A.M.S. vessels	†48/45
"Egeria", Channel Patrol Boat - Change of name	256/45
Electric Fans - H.D.M.Ls.	279/44
Electrician and Ordnance Mechanic Branches	82/44
Equipment in Motor Launches - Replacements	562/44
Switch and Control Gear - Mounting on Resilient	
Mountings in Order to reduce effects of shock	†242/44
Electrodes, securing of Floats to - "L.L." Sweepers	†20/45
Eligibility of Telegraphist Ratings for Exemption in certain	
subjects of the examinations for P.M.G. Certificates	75/44
Embossing of Cans for Meat Packs	174/45
Emergency rations for Aircraft operating from H.M.A. Ships	67,445/44
Water ration for personnel at sea - Supply of Water	
Bottles	156/44
Employment and hours of work for skilled tradesmen	65/45
Empty Gas Cylinders - return of	48/44
Enemy Ammunition	585/44
Equipment	522/44
Submarines - Attacks by Surface Craft on	†5/45
Engine Operating Hours between overhauls - Fairmile Motor Launches	344/45
Register - M.Ls	386/45; 162/44
Room Bilges - Pitting in - A.M.S. Vessels	†69/44
Ratings - Examination of	198/45
- Results - April 1942	92/45
1945	652/45
- September 1945	15/44
- March 1944	544/44
4/45	
- Training of	
Engines - Internal Combustion - Preparation for stowage, etc.	
after removal from boat	682/44
Entry into the Naval Forces - Examination and Record Form -	
Form A.M.6	455/45
to enclosed wharves - Authority under National Security	
(General) Regulation 7A	495/45

† Denotes C.C.N.O.

Subject	E - contd.	C.N.O. or C.C.N.O. No.
Equipment and Fittings - New Constructions		451/45
- A/S in M/Ls. - R/T Interference		†61/44
- Asdic, Half-Yearly Reports on		†19/45
- D/F - Alteration and Addition - Fitting of D/F Equipment A.W.A. Type C145A - A.M.S. Vessels		†85/45
- D.G. and S.A. Voltage Regulation in Auxiliary Mine- Sweeping Vessels fitted with		†14/45
- Diving	†115/45;	105/44
- Echo Sounding - Periodical Material Reports		†16/45
- Fire Fighting - Advanced Base Ports		512/45
- Trials - Reports		161/44
- I.F.F. - Return of Type A.B.K. Sets to Store on re- placement by Radar Type 253		†96/44
- Life Saving - Red Distress Signals and Bensedrine Tablets		†154/44
- Sleeves and Torches for Inflatable Lifebelts	126,212/44	
- Small Ships - Maintenance of		42/45
- Radar - Allocation of		†142/44
- Test - A.M.S. Vessels	†14,†71/44	
- R.M.S. and B.S. - Afloat		†13/45
- Sperry and Commercial Gyro Compass - Maintenance		†51/45
- Testing A/S - Fairmiles and H.D.M.Ls.		†74/45
- U.S.N. Type Radar - Spares for		†53/44
- Web - Pattern 1937		157/44
- W/T Testing - for Frigates		194/44
Escapes from Enemy Territory		51/45
Escort Organization - Convoy	†121/45;	†51/44
Refresher Training Organization		†55/44
Vessels fitted with Radar - Modification to Bridge Chart Table		†154/44
Establishment Lists - W/T, A/S, Radar etc. Equipment	511,502/44	
of Chart Folios - H.M.A. Ships		†190/44
Establishments - H.M.A. Shore - Name Ships		270/44
- Payment of Allowance for Charge of Naval Armament Stores		255/45
- of Small Arms for Shore Bases		†20/44
- R.A.N. - Naval Stores		625/44
Euston Reef Beacon - Radar Reflector		†119/44
Evaporator Systems - Modifications to H.M.A. Frigates		†150/44
Examination and Classes for Seaman Petty Officer and Leading Seaman for Petty Officer Writer and Supply Petty Officer	215,305/45	
the rank of Paymaster Lieutenant-Commander, R.A.N. of Engine Room Ratings	212/45;202/44	
Results - August, 1942	198/45;	355/44
- April, 1943		92/45
- September, 1945	457,652/45	
- March, 1944		15,191/44
Sick Berth Staff - Results - November, 1942		544/44
- May, 1943		91/45
- November, 1945		485/45
- May, 1944		104/44
- Professional for Higher Rating - Date of Passing Warrant Engineers and Warrant Mechanicians		458/44
Writer and Warrant Supply Officer	286/45;	354/44
Writers and Warrant Supply Officers		553/44
- Sick Berth Staff - Results - November, 1943		504/45
Excessive Temperatures of R.U. Ammunition		104/44
Executive Officers - Radar Courses for		186/45
Exercise of Powers of arrest under National Security Act 1939-1945		†115/44

† Denotes C.C.N.O.

Subject	E - contd.	O.N.O. or C.C.N.O. No.
Exhaust Pipes - Modification of - Fairmile M.Ls.		†152/45
Exhaustion of Supply of Rubber		296/45
Expenditure - Abnormal - Accumulators		181/44
- D.C. - Six months ending 31st December, 1942 - Analysis - 1942		†8,79/45
1945		†42/44
on behalf of Netherlands - Classification		187/44
Explosive Charges in Patrol Craft		†99/45
Explosives ex H.M.A. Ships - Annual Inspection		111/44
in Small Ships and D.E.M. Ships - Handling		†397/45
- Periodical Examination of		277/44
- in Shore Establishments other than Naval Armament Depots		488/45
- Storage in buildings other than Magazines or Explosives Stores		569/44
External and Camouflage Painting - Standardisation of Colour Shades and Introduction of A1 and A2 Glass qualities paint		400/45
Extra Issues of Provisions - Fruit and Tomato Juices		672/45
Extractors - O.Q.F. 4-in. Mark XVI* Guns		†11/44
Eye Shields - Anti-Gas - and Ointment - Revision of Allowances		209/44
Eyeshooting Sights - Short Range A.A. Weapons		148/45

F

Failure of Armament material and ammunition - rendering of Forms S.1148 (h), (i) and (j)		294/44
Gun Armament material and ammunition		144/44
on 2-in. U.P. Pillar Box Mountings		577/45
Failures - P.A.C. Rockets		5/44
Fairfax, Naval Officer-in-Charge		†55/45
Fairmile Identification Lettering		552/45
Motor Launches - Engine Operating Hours between overhauls - Modification of Exhaust Pipes		344/45
to Circulating Water System		†152/45
- Permissible Revolutions		526/45
Patrol Boats Type "B" - Alterations and Additions	†195,†229/44	
- C.S.A. Smoke Apparatus and Type "F" Smoke Floats		†209/44
Personnel - Periodical Medical Examination of		340/45
Rudders		295/44
Type "B" Motor Launches - Slipping of		12/44
Fairmiles, H.D.M.Ls. and A/S Rescue Boats - Supply of Medical Stores - Testing Equipment		44/45
Fan Engine - Steam Driven Boiler Room - Vibration of - A.M.S. Vessels Ventilating - Loss of		†125/44
Fans - Electric - H.D.M.Ls.		66/44
- Steam Driven Boiler Room - Modification to A.M.S. Vessels		279/44
Fares - Concession Railway - Service Personnel Travelling in Uniform and paying their own fares		195/44
of Relatives attending funerals of deceased service personnel - payment of		645/44
Feed Pumps - Weir Type		274/44
Fenders - Wattle Rod		504/44
Fighting French Warships - Cash advances for		280/44
Filling Recoil Cylinders - 4-in. Gunsighting Marks XXIII and XXIII*		†75/44
Films - Instructional - Disposal of Obsolete and Unserviceable Films - Radar Instructional		145/44
		296/44
		†155/45

† Denotes C.C.N.O.

Subject	F - contd.	C.N.O. or C.C.N.O. No.
Fire and Repair Parties, Protective Clothing for	280/45
Smoke Risks in H.M.A. Ships, Reduction of -		
C.A.F.O. 2565/42 - Application in the R.A.N.	†45/45
Types of Paint to be used for Interior Painting	569/44
Control Arrangements - H.M.A. Frigates	†287/44
- Higher - Payment of Allowance	180/45
- Radar Offices	124/44
Extinguishers for Motor Launches	416/45
- Recharging of Cylinders for "Nuswift", "Groviner" and "Essex" Type	659/44
Fighting and Action Repair Materials - Stowage for - Minor War Vessels	†179/44
- Asbestos Clothing for	621/45
Equipment - Advanced Base Ports	512/45
- Trials - Reports	161/44
in H.M.A. Ships - Alterations and Additions - A.F.O. 5595/45	†97/44
School	664/44
Precautions - Coastal Craft	70/45
- Prevention of - in Motor Boats	258/45
Firearms, Private	229/45
Fireman at Station 54 - Modification - A.M.S. Vessels	570/44
Firings, Full Calibre	4/45
First Aid Medical Kits	70/44
Fitting of Additional Armament in H.M.A. Ships	†46/44
Foam Equipment for Fire Fighting	578/45
Spare Parts supplied for O.Q.F. 4" Mark XVI* 20 m.m. Oerlikon Barrels	†95/45
	572/45
	†45/45
Five lb. T.N.T. Charges for Harbour Defence	
Flag of Vessels of Water Transport Units of the Australian Military Forces	640/45
Wallet - Canvas - for A.M.S. Vessels	114/44
Flags - British U.S. Communications	557/45
on Commonwealth Buildings	6/44
- Precautions to be taken in washing	557/44
- Unserviceable and Inglefield Clips - Return to Store	69/44
Flashless Propellant	†144/44
Fleet Attendant Oilers - Use by Torres Strait Pilots	†70/45
- Eastern - Address of Commander-in-Chief	†90/45
Flexible Shafting for Boiler Tube Cleaning Apparatus	15/45
Floats, securing of, to Electrodes - "L.L." Sweepers	†20/45
Flour	152/45
- Tax, refund of	459/44
Food Coupons - Naval personnel	266,605/44
- Hygienic handling and proper cooking of	80,155/45
Rationing and Food Economy - General Instructions	265/44
- Wastage of	†16/44
Foodstuffs and Cooking Arrangements - Inspection of	154/45
Football Boots	550/45; 556/44
Foresights - 40 m.m. Bofors Gun Mountings	548/44
Form A.D. 495 - (Report of Docking) and Form A.D. 488 (Propellers and Underwater Fittings) - Procedure	354/45
A.M. 22 - Prevention of Disease and Maintenance of Health in Tropical Climates	559/44
A.M. 6 - Medical Examination and Record Form for Entry into the Naval Forces	455/45
A.M. 114Z - Report of Seasickness	449/44
A.M. 177G - Medical Store Account for Scale "C" Medical Store	222/44
A.M. 301Z - Medical Status of Personnel recommended to be in- validated - introduction	347,510/44

† Denotes C.C.N.O.

Subject	F - contd.	C.N.O. or C.C.N.O. No.
Form - contd.		
A.O. 52 - Weekly Ammunition Stock Reports	589/45
A.S. 25 - Safeguarding of Personal Money	106/45
A.S. 98 - Revision of	126/45
A.S. 98A - Revision of	126/45
A.S. 105Y and A.S. 105Z - Introduction of	242/44
A.S. 151 - Consumable Naval Store Ledger Sheets - Amendment of	246/44
A.S. 155X - Record of Naval Store Ledgerkeepers - Introduction of	298/44
A.S. 214 - Use during hostilities	195/45
A.S. 288A - "Annual Diving Return" - Rendition of	110/45
A.S. 559Z - "Long Leave Book"	9/44
A.S. 542 - Route Order and Travelling Expense Claim	155,455/45
A.S. 1048 - Daily Abstract of Clothing Issued on repayment	156/45
A.S. 1246V - Coder's History Sheet	627/45
D.E.M.S. 16 - Local Rendering for Paravane losses due to failure of Towing Ropes	52/45
N.A. 5 - Consecutive Number of paid voucher to be inserted by Paying Office	255/44
N.M.T. 7 - Instructions for drivers of Naval Motor Services	689/44
O. 426 - History Sheets for D.C. Pistols	94/44
S. 102 and 105 - Records of issue and return of loan clothing	601/44
S. 1147A - Cordite Temperature Return - R.A.F.A's., Auxiliary A/S and M/S Vessels	†101/45
- Quarterly return of temperature of storage of Cordite - Non-rendering	†100/44
S. 1148	421/44
S. 1516 - Reports on - R.M.S.	165/45
T. 406 - Overtime and Extra Payment	572/45
Forms and Cash Vouchers - Captain's signature	150/44
Books - see Books and Forms		
- Economy in use of - demands for Victualling Stores	255/45
- Medical and Rehabilitation - Completion of, for Discharged Personnel	692/44
- Printed	409/44
Forwarding of C.W.I Forms	79/44
Free Kits - Issue of, to Ratings on entry	54/44
Freight and travelling warrant books - Disposal of	659/44
Fremantle - Torpedo Depot	†65/44
Fresh Provisions - Contract Rates - at Melbourne	101/44
- Supply of - at Melbourne	194/45
- at Sydney	194/45
Water supplies in H.M.A. Ships	658/44
Frigates and A.M.S. Vessels - Modification to Evaporator System	†68/44
- H.M.A. - Modification to Evaporator Systems	†150/44
- Naval Store Accounting Procedure	244/44
- "River" Class Corvettes - Reclassified as With reciprocating main engines - maximum continuous power	†42/45
	†53/44
Fruit - Accounting for purchases and issues of - in Provision Accounts of Ships and Establishments	301/45
and tomato juices - extra issues of provisions	672/45
Fuel Oil(a) - Burning of	295/45
- Measuring Tapes	270/45
- Naval Stocks in Australia	†15/44
- Nomenclature of	474/45
Full calibre Firings	†4/45
Funds - Ships'	219/45
Funerals of deceased service personnel - payment of fares of relatives attending	274/44
- Payment of Contractors' Claims in connection with	555/45; 250/44

† Denotes C.C.N.O.

Subject

C.N.O. or
C.C.N.O. No.

F - contd.

Furniture - Steel - Supply to H.M.A. Ships	356/44
- Wooden - Replacement by Steel, in Cruisers, Destroyers, A.M.S.Vessels and "Warrego" and "Swan"	354/44
Fuse No.127 Mark I, I ^a and II, Keys, Modified setting stud	291/43
Fuses - No.401, Mark II Lot 146 V.A.O. filled 10/41 - Withdrawal from service for 100 per cent examination	53/44
- No.720 - for use with U2" H.E.Shell	635/43
- Percussion D.A. No.250 - Marks to be used for guns in Twin Mountings	†65/45
- Returned from ships - time mechanical - Amendment of C.B. 5065 (N.M.E.R.)	†144/43
- Time No.401 Marks I and IA	153/44
- On Board H.M.A.Ships - Annual percentage in wartime	253/44
F.X.R.Gear - Counter Measure to Acoustic Homing Torpedo	†120/44

G

Gaiters - Canvas Hose to prevent chafing	195/45
Galley Shoes for Cooks - W.R.A.N.S.	77/44
Gaols - Civil - Subsistence of persons in	227/43
Garbage and ashes from H.M.A. Ships at Outer Harbour and Port Adelaide - Disposal of	313/43
Gas Cylinders	450/43
- Boxes for	619/45
for Engineering and Medical purposes - marking Medical purposes	234/45
- Loss of - Reports	528/45
- Return of Empty	67/43
Contractors'	48/44
- Water Pressure Test	99/44
- Use of by Enemy - Responsibility for identification and Procedure for reporting	99/43;295/44
Gases - Industrial Cylinders for	†24/45
Gate Vessels - and Boom Working Vessels - Additional Armament	262/44
Gear - Cleaning, Economy in the use of	†57/45
General Instructions - Food rationing and food economy	293/43
Message of "H" and "I" Series remaining in force	265/44
Generating Sets - Kelly and Lewis Steam Driven - A.M.S. Vessels - Governors	140/44
Generators - Diesel - Exhaust Pipes	310/43
- Stiffening of Seatings of Kelly and Lewis Steam- driver - A.M.S. vessels - Alterations and additions	428/44
Gift Parcels sent to the United Kingdom from H.M.Forces Overseas - Duty Free Concessions - Army Form W.5192	†104/44
Girl Guides' Holiday Gift to the R.A.N. Patriotic Fund of Victoria	444/45
Glassware, Earthenware and China - Shortage of supplies	555/43
Goggles - Protective - for Sun Sector Lookouts - Introduction	352/43
Gold Lace and other Articles made of Gold Bullion - Renovation of	459/43
Good Conduct Badges	9/45
- Counting of previous service toward award	486/43
Service Badges - R.A.N.R. - Deprivation and Restoration	589/44
Government Stores - Misappropriation - Reports to Civil Police	61/44
Governors - Kelly and Lewis Steam-driven Generating Sets - A.M.S. Vessels	72/44
Grant for Tropical Kit	310/43
of full and modified "Qualified Officer" status in the R.A.N.	77/45
- Special Uniform - to Officers travelling with a minimum of Baggage	74,152/44
	159/45

† Denotes C.C.N.O.

Subject

G.N.O. or
C.C.N.O. No.

G - contd.

Grants-in-Aid and Percentage Charge - Orchestral Band	
Instruments	197/44
Gratuities - Outfit - on Change of Class of Uniform	250/44
Gratuitous Issues of Uniform and Clothing to British and Allied Services	661/44
Replacement of Officers' Mess Traps and Seamen's Mess Utensils	8/45
Gratuity, Outfit, Tropical - Sydney	297,476/43
- Lieutenant (Emergency or Retired) - Payable on promotion from commissioned warrant officer or warrant officer	211/44
Graves Registration Burials - Identification of Bodies and Burial of Enemy Dead	15/45
Greatcoats for Naval Chaplains - Supply of	680/44
- Naval Auxiliary Patrol	581/45
Grenades, Drill No.56 M.	324/43
Guard Rail Stanchions on Forecastle - A.M.S. Vessels	†166/44
Gun Ammunition - Reserves of, at Australian Ports and in A.S.I. ships and Gun Mounting - Range Tables - O.U. Books and Books of Reference	†6,†100/45
Armament Material and Ammunition - Failure of	†68/45
in Small Ships - Maintenance of	144/44
- Reports on failure of	31/45
Mounting Holding Down Bolts	500/45
Mountings - Test of Recoil Cylinder Liquid	184/45
- 12-Pdr.	192/44
Trials - Procedure	183/45
- Reports - Elevating and Training efforts	38/44
- 4-inch Gunmounting Marks XXIII and XXIII*	529/44
Gunfire A.A. from H.M.A. Ships in Harbour	†57/44
Gunmounting, Naval Armament and Torpedo Stores - Despatch of, to Melbourne	†77/45
- 40 m.m. Bofors	420/43
Gunmountings - 4-inch Marks XXIII and XXIII* - Filling Recoil Cylinders	559/43
Gunnery Communications - A.M.S. Vessels	143/44
Equipment - D.E.M.S. - Painting of	†7/44
Ratings - D.E.M.S. - Badges	350/44
- Higher - Qualifications at sea	93,358/44
- Qualifications at sea	228/43
Guns and Gun Mountings - Bofors - Care and Maintenance	296/43
- 40 m.m. - Foresights	103/44
- Issues, Receipts and Inspections - Details to be treated as confidential	548/44
- Inspection after firing	235/45
- Machine, 20 m.m. Oerlikon - Gauges Striker Protrusion and high diameter	†140/43
.50" - Gauges Plug Bore Low Limit for Provisional Condemnation	595/45
M.G. Mark I and Rods Plug Bore .50" M.C. Mk.I	387/45
.305" Bren and .305" Vickers G.O. - Modifications to	
Magazines and Repair	
Magazine Main springs	594/44
Mark I - Springs Return Mk.II	185/45

† Denotes C.C.N.O.

Subject

G - oontd.

Guns and Gun Mountings - Machine, .305" - contd.	
- Lewis - Conversion of Mk.IV Sights (100 Knots) to Mk.V (200 Knots) and Fitting of Mk.III Butt Plate ..	352/44
- Vickers G.O. - Modifications to prevent wrong assembly on Single A.A. Mountings - Butts for ..	395/44
- Oerlikon ..	477/44
- 20 m.m. - Tool, Loading Magazine - Introduction ..	325/45;595/44
- Oerlikon - Ammunition for - Pools maintained at Ports and Outfits to be supplied ..	125/45
- Mark II and IV - Collapse of Barrel Springs Mk.I ..	5/45
- Modification of Shoulder Rest	550/44
- Spare Parts ..	290/45
- 20 m.m. - Adaptor for oleating rods - introduction	†28/43
- Care and Maintenance	407/44
- Locking of Barrels	179,349/44
- Spares Appurtenances, etc. - Basic Sets	530/44
. O.Q.F., 4-inch XIX - Assembly of Sear to Case Striker, Mark I	596/45
XVI* ..	266/45
XVI* - Extractors ..	†11/44
- Q.F. 5 in 20 cwt. Mk.I, IB - IE Pins Axis Breech Mechanism Lever Catch Mk.I to be replaced by Mk.II ..	351/44
40 m.m. - Method of Testing Blow of Striker ..	306/44
- Report of Stock and Transactions ..	443/44
- Sub-Machine Thompson 0.45-in., Tool Recoil Spring - Instructions for ..	†44/45
- 2-pdr. Mk.XIV Replacement in "B" Type M.Ls. by 3-pdr. Mk.V and 2-pdr. Mk.VII*	442/44
- 4-in. XIX, Re-arming with, on H.A.L.A. XXIII* Mounting - H.M.A. Ships ..	260/44
- 4-in. Mark XXIII and XXIII*	208,592/44
- Elevation Buffer Stop - Replacement of Spring by Distance Piece	372/44
- Firing Gear - Modification to Catch Piece	374/44
- Lower Elevation Gear Box - Fitting of Leather Washer	375/44

† Denotes C.C.N.O.

Subject

G - oontd.

C.N.O. or
C.C.N.O. No.

Guns and Gun Mountings - 4-in. Mark XXIII and XXIII* - contd.	
- Lubrication of Centre Pivot	566,637/44
Gymnastic Shoes for W.R.A.N.S. ..	19/44
Gyro Compass (Brown Type "A") - Replacement of 2 mfd. condensers in transmission Spark Quench Circuit ..	590/44
Equipment, Mark XIV - Instructions - Mod.I. Oiling Chart, Item 15 ..	598/45
- Sperry Commercial - Maintenance ..	†31/45
- Sperry Mod.I Mk.XIV - Condensers - Follow up Circuit - Incorrect filling of transmitter connecting cables ..	379/44
- Mercury Ballistic Caps ..	314/44
- Oiling of Upper Vertical Guide Bearing ..	378/44
- Repeater Bezel Screws ..	376/44
Gun Sights - Modification to 20 m.m. Oerlikon Mountings	377/44
- Housing Oerlikon Guns fitted with Mk.XIV ..	†139/45
- Mk.IV - Fitting to Mk.VIIA Oerlikon Mountings ..	254/44
- U.S. Mk.XIV ..	†165/44
	†253/44

H

"H" and "I" Series - General Message of - remaining in force ..	140/44
Halling equipment - A.M.S. Vessels - Alteration and Addition Item C.A.F.O. 5963/45 ..	†108/44
"Half-Cock" Position - Depth Charge Pistols ..	†145/45
Half-Yearly Reports on Asdio Equipment ..	†19/45
A/S Equipment - Record of Personnel ..	†148/44
Hammocks - Labelling and Marking of ..	57/45
Handbook and Drill for 20 m.m. Oerlikon Machine Gun - B.R.274/41 - Amendment to Drill ..	371/45
on Lookouts and Service Optical Instruments - B.R.797 (1943) - Amendments ..	340/44
Hand-up Chutes for 4" Ammunition ..	†180/44
Harbour Defence - 5 lb. T.N.T. Charges for ..	†45/45
Signals to denote air raid warnings ..	†23/45
Haversacks - Painting of - Anti Gas Respirator ..	382/44
Hawser - Towing - A.M.S. Vessels ..	401/45
Haze Screens - R.A.N. Pattern - Modification ..	134/44
H.D.M.Ls. and Fairmiles - A/S Testing Equipment ..	†74/45
- Extraction of Fumes from Refrigerator ..	679/45
- Operating Hours ..	645/45
Health - Prevention of disease and maintenance of health in tropical climates ..	539/44
Heat Treatment of Shuttle Valves of Reciprocating Pumps ..	107/44
Hedgehog - Nomenclature to be used when demanding Stores ..	†182/45
Heeling Error Instruments for D.G. purposes ..	546,659/45
Heliographs, Binoculars, Telescopes and Watches - Muster of ..	397/44
Helmets - Sun and Khaki Covers ..	192/45
Higher Duties - Applications for Payment of Difference in Pay to Rating Performing - N.F.R.I., Art.74 ..	365/45
Educational Test - Results - October, 1942 ..	104/45
- April, 1943 ..	358/45
- October, 1943 ..	156,248/44
- April, 1944 ..	459/44

† Denotes C.C.N.O.

Subject

C.N.O. or
C.C.N.O. No.

H - contd.

Higher Fire Control - Payment of Allowance	180/45
Gunnery Ratings - Qualifications at Sea	228/45
Rating, Professional Examination for - Date of Passing ..	179/45
History of the War - Naval Medical	75/44
Sheets and Keys, Depth Charge, Pistol, Depth Adjuster -	
Disposal	149/45
-Depth Charge Pistol	54/45
- Details required	145/44
- Form O.426	94/44
H.M.A. Frigates and H.M.A.S. "Orara" and "Kybra"	†185/44
H.D.M.L. 1161 - Paying off	†50/44
1521 - Commissioning	†156/45
1522 - Commissioning	†18/44
1525 - Commissioning	†19/44
1524 - Commissioning	†157/44
1523 - Commissioning	†149/45
1526 - Commissioning	†25/44
1529 - Commissioning	†159/44
1558 - Commissioning	†129/44
1559 - Commissioning	†147,†172/44
1540 - Commissioning	†110/44
1541 - Commissioning	†278/44
1542 - Commissioning	†173/44
1545 - Commissioning	†227/44
1552 - Commissioning	†109/44
1555 - Commissioning	†256/44
1554 - Commissioning	†285/44
1557 - Commissioning	†255/44
1558 - Commissioning	†244/44
1559 - Commissioning	†220/44
809 - Commissioning	†124/45
810 - Commissioning	†134/45
811 - Commissioning	†148/45
812 - Commissioning	†161/45
817 - Commissioning	†162/45
824 - Commissioning	†159/45
825 - Commissioning	†29/44
826 - Commissioning	†4/44
827 - Commissioning	†91/44
Paying Off	†269/44
- H.D.M.Ls. ex U.S.A. - Fitting of Twin Vickers .305" Mountings -	
Alterations and Additions	455/44
- M.L. 450 - Paying Off	†187/44
- Radar School - Correspondence	441/44
- Ships - Aircraft Operating from - Emergency Rations for	67/44
and Establishments - Photographic Material for use in	8/44
- Reduction of Kits in	241/44
Attached to Eastern Fleet - Service Certificates and	
Pay Accounts	57,440/44
- Coal for - Procedure Governing Supplies	52/44
- Code and Cypher Machines - Installation in	†112/44
- Depth Charge Throwers - Position, Angling and	
Clearances from Ship's Side	†116/45
- Drydocking - Precautions to be observed to prevent	
damage to Asdio Gear, etc.	525/45
- Emergency Rations for Aircraft Operating from	67,445/44
- Establishment of Chart Folios	†190/44
- Firefighting in - Alteration and Additoon - A.F.O.	
5593/45	†97/44

† Denotes C.C.N.O.

Subject

C.N.O. or
C.C.N.O. No.

H - oontd.

H.M.A. - Ships - oontd.	
- Fitting of Additional Armament in	†46/44
- Fuzes, Time, on Board - Annual Percentage	
Landing in Wartime	255/44
In Harbour - Anti-Sabotage Measures by	†76/44
- Maintenance of Upper Deck Fitting	178/44
- Photographic Record of	641/45
- Re-arming with 4" XIX Guns on H.A.IA XXIII*	
Mounting	260/44
- Signatures of Issuing Officers on Travelling	
Warrants	674/44
- Sun Reflecting Device for	53/44
- Supply of Steel Furniture to	356/44
- Ventilation of	454/44
- Zinc Sheets and Underwater Protection of Ships and	
Fittings	517/44
- Shore Establishment - Name Ships	177,629/45;†590/44
- Payment of Allowance for Charge of	
Naval Armament Stores	255,574/45
H.M.A.S. "Air Chief" - Commissioning	†186/44
"Air Clan" - Commissioning	†286/44
"Air Cloud" - Commissioning	†246/44
"Air Host" - Commissioning	†245/44
"Air Master" - Commissioning	†201/44
"Air Mist" - Commissioning	†216/44
"Air Rest" - Commissioning	†218/44
"Air Sailor" - Commissioning	†254/44
"Air Save" - Commissioning	†217/44
"Air View" - Commissioning	†265/44
"Air Watch" - Commissioning	†274/44
"Air Wave" - Commissioning	†215/44
"Alatna" - Commissioning	†28/44
"Alexander Thompson" - Paying Off	†267/44
"Alfie Cam" - Paying Off	†158/44
"Allenwood" - Paying Off	†249/44
"Allura" - Commissioning	†111/44
"Arcadia" - Commissioning	†6/44
"Arista" - Paying Off	†92/44
"Baroco" - Commissioning	†17/44
"Bermagui" - Re-commissioning	†5/44
"Bombo" - Paying Off into Reserve	†147/45
- Commissioning	†27/44
"Borough Belle" - Commissioning	†172/45
"Burdekin" - Commissioning	†178/44
"Burrabra" - Paying Off	†127/44
"Cape Leeuwin" - Commissioning	†109/45
"Coolebar" - Re-commissioning	†58/45
"Cowra" - Commissioning	†146/45
"Emilea" - Paying Off	†66/44
"Forceful" - Paying Off	†156/45
"Gascoye" - Commissioning	†150/45
"Geelong" - Paying Off	†257/44
"Gippaland" - Paying Off	†126/44
"Goonabee" - Paying Off	†156/44
"Gunbar" - Paying Off	†52/45
- Re-commissioning	†152/44
"Harman" - Commissioning	186/44
"Hawkesbury" - Commissioning	†154/44
"Hoonah" - Paying Off	†165/44

† Denotes C.C.N.O.

Subject

H - contd.

H.M.A.S.	Subject	C.N.O. or C.C.N.O. No.
-	contd.	
-	"Jester" - Paying Off	†196/44
-	"Jon Jim" - Paying Off	†279/44
-	"June" - Change of Name	517/45
-	"June" - Commissioning	†76/44
-	"Kanimbla" - Commissioning	†171/44
-	"Karina" - Commissioning	†275/44
-	"Kiama" - Commissioning	†22/44
-	"King Bay" - Commissioning	†155/45
-	- Paying Off	†54/44
-	"Krait" - Commissioning	†77/44
-	"Kuranda" -	256/44
-	"Kweena" - Paying Off	†60/44
-	"Ladava" - Commissioning	†108/45
-	"Larrakia" - Paying Off	†49/44
-	"Larus" - Commissioning	†290/44
-	"Limicola" - Commissioning	†226/44
-	"Limosa" - Commissioning	†255/44
-	"Lookout" - Re-naming	666/45
-	"Madang" - Commissioning	228/44
-	"Marlean" - Paying Off	†254/44
-	"Maroubra" - Paying Off	†52/45
-	"Marynong" - Commissioning	†119/45
-	"Mafona" - Paying Off	†94/44
-	"Metafele" - Paying Off	†171/44
-	"Narani" - Paying Off	†192/44
-	"Nepean" - Paying Off	†266/44
-	"Pendion" - Commissioning	†191/44
-	"Parkes" - Commissioning	†124/44
-	"Pedare" - Paying Off	†114/44
-	"Pioneer" - Paying Off	†150/44
-	"Poyang" - Commissioning	†166/45
-	"Rathane" - Paying Off	†95/44
-	"Reserve" - Commissioning	†102/45
-	"Resurgum" - Paying Off	†159/44
-	"Rushcutter" - Organization	102/45
-	"Silver Cloud" - Paying Off	†72/45
-	"Shropshire" - Transfer to R.A.N.	†47/45
-	"Sprightly" - Commissioning	†59/44
-	"Starfish" - Paying Off	†165/45
-	"Strahan" - Commissioning	†59/44
-	"Summit" - Paying Off	†160/44
-	"Sundowner" - Paying Off	†157/44
-	"Sylph" - Paying Off	†95/44
-	"Tasma" - Paying Off	†45/44
-	"Three Cheers" - Commissioning	†247/44
-	"Tiger Snake" - Commissioning	†202/44
-	"Tongkol" - Paying Off	†151/44
-	"Topay A" - Paying Off	†101/44
-	"Valangen" - Commissioning	†155/45
-	- Paying Off	†85/44
-	"Vigilant" - Commissioning	†90/44
-	- Re-naming	285/44
-	"Viking" - Re-naming	286/44
-	"Wallaroo" - Paying Off	†40/45
-	"Wangala" - Paying Off	†174/44
-	"Westralia" - Commissioning	†5/44
-	"Westwind" - Paying Off	†268/44

† Denotes C.C.N.O.

Subject

H - contd.

C.N.O. or
C.C.N.O. No.

H.M.A.S.	Subject	C.N.O. or C.C.N.O. No.
-	contd.	
-	"Whang Pu" -	†84/44
-	- Commissioning	†120/45
-	"Wongalere" - Paying Off	†125/44
-	- Re-commissioning	†155/44
-	"Tunnan" - Commissioning	†214/44
H.M.A.	Submarine "K9" - Commissioning	†59/45
-	- Paying Off	†67/44
-	Tug "Toorong" - Commissioning	†155/45
-	Victualling Depots	542/44
-	Yard, Port Melbourne	352/45
H.M.S.	"Golden Hind"	†252/44
H.M.Ships	transferred to R.A.N. for Manning - Arrangements in respect of the Agreement between the U.K. and the Australian Governments	†51,227/44
-	Hobart - Naval Officer-in-Charge - Mails and Correspondence for Holding Down Gun Mounting Bolts	362/45
-	Homing Torpedo - Acoustic - Counter Measures to - F.X.R., Gear	184/45
-	Honorary Membership for Officers - Royal South Yarra Lawn Tennis Club, Melbourne	†120/44
-	Honours, Awards and Decorations - R.A.N. Personnel	112/45
-	12,85,211,555,494/45; 200,288,515,679/44
Hose Couplings	- India Rubber Washers for - use of correct patterns	144/45
-	Tubing - Canvas - Prolonging Life	92/44
Hospital Claims	- Newcastle	55/45
-	- Naval, Darwin	52/45
Hospitals	- Private - Approved - Rates of treatment in	217/45
-	- for Naval Officers	505/44
Housing	Oerlikon Guns fitted with Mk.XIV Gyro Sights	254/44
Hygiene and Sanitation	- General - including the Prevention of Malaria - Preservation of Health	269/44
Hygienic Handling	and proper cooking of Food	80,155/45
Hypodermic Outfit	- Individual Morphine Sulphate Gr. ½ or Omopon Gr. 2/5 (Tubunio Ampoule or Syrette)	379/45
I		
Ian Macdonald Memorial Prize	380/45;365/44
Identification Lettering	- Fairmile	352/45
-	of bodies and burial of enemy dead, graves registration - burials	15/45
I.F.F. Equipment	- Return of Type A.B.K. sets to Store on re- placement by Radar Type 200	†96/44
Igniters, Torpedo. Mark XI	- Lot No.144, Filled S.W.Y.N. 9/41 - Withdrawal	64/44
-	No.217, Filled B.R.12/41 - Withdrawal	155/44
-	Withdrawal (A.F.O.4082/45)	590/45
Illuminating Rockets	5½ lb. - Prematures	40/44
Illumination of Sight Dials	- 4" Mark XXIII* Mountings	327/44
Important Keys	268/45
Imprisonment or Detention	- Disposal of Ratings after sentence of	250/45
Income Tax Returns	377/45;455/44

† Denotes C.C.N.O.

Subject	G.N.O. or C.C.N.O. No.
I - contd.	
India Rubber Washers for Hose Couplings - Use of correct patterns	144/43;554/44
- United Kingdom Air Mail	365/44
Indicator Loop Identification Signal Apparatus	†258/44
Industrial Gases - Cylinders for	681/45;262/44
Infantry, Landing Ships - Administration	†117/44
Inflatable Lifebelts - Torohes and Sleeves for - Life Saving Equipment	126,212/44
Information - Disclosure of - Service Matters	507/45
Inglefield Clips and Unserviceable Flags - Return to Store	69/44
Pattern 100 - Defence in manufacture	671/44
Injuries and Wounds by Enemy Action	550/44
Innoculation against cholera	149/44
Inspecting Accountant Officer	428/45
Officers, Principal Naval Overseers and Overseers - Directions for	568/45
Inspection - Annual - Explosives ex H.M.A. Ships	111/44
of Foodstuffs and Cooking arrangements	154/45
Guns after firing	†140/45
Rifles	551/44
Service Certificates	558/45
Installations - Asdic - Types 144/3 - Training of Personnel	†70/44
Installation of Permanent D.G. - A.M.S. Vessels	†38/45
Instructions for Accounting, Custody, etc. of Secret and Confidential Books	†170/45
Compiling the Deck Log and Ship's Log	357/45
Naval Armament Store Accounting at certain Shore Establishments	20/45
- Rehabilitation Officers	601/45
Insurance of Canteen and Mess Stocks	140/45
Intercommunication - Mixed Squadron - Installation of V.H.F. R/T Set - Alteration and Addition	†95/45
Interference - R/T - A/S Equipment in M.Ls.	†51/44
With W/T and R/T Reception - Radar Type A286 P/Q	†48/44
Interior - Department of - Naval Stores Expended on Naval Works - Discontinuance of Recovery of Cost of Material for Minor Repairs and Jobbing	404/45
Interstate Rail Travel - Wives and families of Naval personnel	524/45
Introduction of Cartridges M.L.9.5-in. D.C.T. Cordite H.S.C.T.154 - D55, 4-oz. O-D.R.M.S. Mk.XII	†75/44
Rating - Ordnance Artificer (O) - For duties in connection with repair and maintenance of Optical Instruments	72/45
"Invalided" from R.A.N. - Convalescent Leave Prior to Discharge Personnel - Procedure in regard to - Rehabilitation Officers	440/45
Officers	556/45
Invalids - Use of Army Medical facilities in transfer of	641/44
Irregular wearing of Glass III Uniform - Acting Petty Officers	107/44
Issue A.C.B. 247 (R)	85/44
of Clothing to Survivors	529/45
Confidential Navy Orders	196/45;†1/44
Consumable Naval Stores to H.M.A. Motor Patrol Boats and Small Vessels in which Accounts of Consumable Naval Stores are not required to be maintained	575/45
Free Kits to Ratings on entry	154/44
Leave Travelling Concession Warrants	275/45
Loan Protective Clothing to Gunners of Maritime Troop, Royal Artillery, D.E.M.S.	589/45

† Denotes C.C.N.O.

Subject	G.N.O. or C.C.N.O. No.
I - contd.	
Issue of - contd.	
Long Khaki Clothing in the Royal Australian Navy	593/45
Materials - Repayment - Uniform and Clothing Supplies	171/44
Mess Gear and Blankets to Personnel Travelling	170,552/44
Navy Orders	1/45
Uniform and Clothing on Repayment to Personnel of Allied Navies	369/45
Whistles and Lanyards to D.E.M.S. Personnel	657/45
Issues, Receipts and Inspections of Guns and Gun Mountings	255/45
Issuing Prices of Khaki Tropical Clothing	27/45
J	
Jackets of Petty Officers and Men not dressed as seamen - Alteration to	245/45
Joist Adjuster Rings I.R.	455/45
Journal "Salt" and "Current Affairs Bulletin"	155/45
Journals - Medical Officers	527/44
Junior Writer and Supply Ratings - Typewriting experience	176/44
K	
Kelly and Lewis Steam-driven Generating Sets - Governor - A.M.S. Vessels	510/45
Generators - Stiffening of Seatings - Alteration and Addition - A.M.S. Vessels	†104/44
Keys, Duplicate, etc.	†141/45
- Fuse No.127, Mk.I, I* and II - Modified Setting Stud	291/45
- Important	268/45
of Safes and Chests in Small Ships	†52/44
Khaki Covers and Sun Helmets	192/45
Tropical Clothing	402/45
- Additional Supply to Ratings serving in Northern Areas	170,624/45
- Issuing Prices of	127/45
King's Regulations and Admiralty Instructions - Reprint	587/44
Kitbags - Labelling and marking of	57/45
- Small	258/45
Kit - Authorized - Uniform and Clothing - W.R.A.N.S.	20,55/44
Lookers - Additional - A.M.S. Vessels	†41/44
- Medical First Aid	70/44
- Modification of Ratings'	172/45
- of Ratings drafted to Darwin, Thursday Island, New Guinea or other Forward Areas in the South West Pacific	285/44
- Prevention of Deterioration in Northern Areas	445/45
- Reduction of - in H.M.A. Ships and Shore Establishments	241/44
- Variations in - Small Blue Kit Bags and Suit Cases	254/44
Kites and Drogues - for use as Anti-Aircraft Targets - Discontinuance of Supply	146/44
"Knock for Knock" - Navy Vehicles	108,519,445/45

† Denotes C.C.N.O.

Subject

C.N.O. or
C.C.N.O. No.

L

Labelling and Marking of Kitbags, Hammocks, Chests and Suitcases	57/45
Lacing of Jackets, Greatcoats and Tunics - Alteration of - Officers of Special Branch	382/45
- Uniform worn by Lieutenant Commanders, R.A.N.R. and R.A.N.V.R.	259/45
Landing Cordite	241/45;90/44
Craft Signalman (Sig.L.C.) - Institution of Non-Substantive Rate	559/45
Parties - Pioneers' Tools for	558/45
Ships - Administration	208/44
Lanterns - Plywood - Radar Types 271/3, A.272 - Maintenance ..	758/44
Launches - Fairmile Motor - Engine Operating hours between overhauls	544/45
- Modifications to Circulating Water Systems	326/45
- Permissible Revolutions	345/45
- Motor - Engine Register	162/44
Leading Stoker Courses	516/44
Leave Concession and Other Railway Travelling Warrants	448/44
or Release - Applications from Naval Personnel for	527/45
- Travelling Concession Warrants - Issues of	275/45
Ledger and Pay Accounts - H.M.A. Ships	467/44
Sheets - Consumable Naval Store - Amendment of Form A.S.151	246/44
Legacy Club, The	625/45
Legal Service Bureaux - Commonwealth	629/44
Lettering, Fairmile Identification	352/45
Letters - Found amongst effects of deceased personnel	56/44
Lewis Guns .305-in. - Stripped - Allowances	580/44
Liability for Pay, etc. - D.E.M.S. personnel	159/45
Liaison between Naval and Air Force Officers engaged on convoy protection	599/45
- Pay arrangements	141/44
Librarian (Female) - Vacancy for - Department of Defence, Melbourne	628/45
Library Books - Purchase Price Limit	225/45
- Supply to Small Ships	207/45
Lieutenant Commander R.A.N. - Paymaster - Examination for the Rank of	202/44
- Naval Reserves - Promotion of Naval Reserve Officers to Rank or Relative Rank of	559/45;607/44
Lieutenant (Emergency or Retired List) - Outfit Gratuity payable on promotion from Commissioned Warrant Officer or Warrant Officer	211/44
Lifesaving Appliances - Provision	252,491/45
- Reports	555/45
Equipment - Red Distress Signals and Benzadrine Tablets	7154/45
- Sleeves and Torches for Inflatable Lifebelts	126,212/44
Rafts - Release of	468/44
Lighters - Ammunition - Loading for Ocean Passages	7199/44
Linen - Bed - Clothes Rationing	185/44
- Table and Table Napkins - Allowances of	317/45
Liquid Human Serum - Supply of	85/45
Liquor - Supply to H.M.A. Ships and Establishments by Australian Army Canteens Service	538/44
Listening Watch - Modification for - Radar Types A.296 P/Q	7113/44
"L.L." Cable Drums - Stiffening of Hand Winding Gear - A.M.S.Vessels	545/44
Minesweepers - Venner Time Switch	87/45
Sweepers - Securing of Floats to Electrodes	720/45
Sweeping Equipment - A.M.S. Vessels fitted with - Protection of L.L.Sweep Switchboards	25/45
Sweep Reel - Failure of Hand Winding Gear - A.M.S.Vessels	339/44
57/3 Cells for L.L.Sweeps - A.M.S.Vessels	78/44
† Denotes C.C.N.O.	

Subject

C.N.O. or
C.C.N.O. No.

L - contd.

Loan Issue - Blankets - Prices or Losses by neglect	59/45
of Blue Combination Suits - N.A.P.	56/45
Brown Dungaree Combination Suits to Officers	58/45;112/44
Rope-soled shoes on H.M.A. Motor Patrol Boats and Naval Auxiliary Patrol Boats	88/45
Protective Clothing for H.M.A. Boem Depots	549/45
Local Rendering for Paravane losses due to failure of Towing Ropes - Form D.E.M.S.16	52/45
Secret Confidential and O.U.Books - Corrections to	7170,7182,7189,7200, 7215,7235,7285/44
Lookers for Damage Control Stores	506/44
Fire Fighting and Action Repair Materials" - A.M.S. Vessels - Alterations and Additions	765/44
- Kit - Additional - A.M.S. Vessels	741/44
Locking of Barrels - 20 m.m. Oerlikon Guns	549/44
Screws of Depth Charge Pistols, Mark VII - IX	124/45
Log(s) - Cypher and Signal - Disposal of	744/44
- Magazine - Auxiliary War Vessels	221/45
- Ship's - and Deck - Instructions for compiling	357/45
London Correspondence	604/44
Long Khaki Clothing in the Royal Australian Navy - Issue of ..	595/45
Loop Repair Vessels - Naming of	7197/44
Loss(es) - Anti-Gas Respirators	355/45
- Bags and Hammocks during Rail Transit	677/45
- Bicycles	426/45
- Dentures and Spectacles through Active Service	347/45
- Gas Cylinders - Reports	67/45
- Naval Stores from H.M.A. Ships due to theft during re-fit, etc., at H.M.A. Naval Yard, Sydney	406/45
- Paravanes - Merchant Ships - Action by D.E.M.S. Staff Officers	76/45
- Pistols, Revolver	18/44
- Tools - Compensation for	184/44
- Ventilating Fan	66/44
Low Power Batteries - Increased Capacity	7276/44
- Mounting on Resilient Mountings in order to reduce effects of shock	7232/44
Lubricating Grease for A.M.S. Vessels	670/45
Oil for Hall Scott Engines	378/45
H.M.A. Ships "Kybra", "Wiloanna" and "Reserve"	109/44
Lubrication Oils and Greases - Standardization and Purchase ..	603/44
M	
Machine Guns, A.A. - Annual Practice Allowance of .305" Ammunition for	77/45
- Bren, .305" Mark I - Springs, return Mark II	185/45
- Lewis .305" - Conversion of Mk.IV Sights (100 knots) to Mk.V (200 knots) and fitting of Mk.III Butt Plate	552/44
- Oerlikon 20 m.m. - Tool Loading Magazine - Introduction	125/45
- Shoulder Shooting Lewis .305"	56/45
- Vickers .305" - Loss in transit	778/45
- .30" - Gauges Plug Bore Low Limit for provisional condemnation M.G. Mark I and Rods Plug Bore .30" M.C. Mark I	587/45
Tools - Co-ordinate use in Australia between the Services	611,685/44
Machinery - Coding - Transport of	724/44
Forms for new construction vessels	658/45
† Denotes C.C.N.O.	

Subject

M - contd.

Machinery - contd.	
- Machine tools, etc. supplied for Naval Workshops -	
Accounting for	108,584/44
of A.M.S. Vessels - necessity for purity of ..	
feedwater	86/45
- Office - Annual Census	22/44
Spares - Organisation for the Provision, Storing, etc.	666/44
Made-to-Measure Jackets and Skirts - W.R.A.N.S. Ratings - Contracts	
for Supply of	406/44
Uniforms - Ratings - Contracts for Supply of ..	405/44
221/45	
Magazine Logs - Auxiliary War Vessels	691/44
Rendering	276/44
Magazines - unloading	454/45
Magnetic Compasses - Boxes for - return when empty ..	626/45
Mail Bags - Return of	362/45
- Correspondence for the N.O.I.C., Hobart	525/44
in H.M.A. Ships - Transport of	457/44
Received at Milne Bay - Damage to	157/45
- Re-direction of	121/45
Maintenance and Care - Oerlikon Guns 20 a.m.	165/44
of Bofors Guns	
Bases on Shore and Repair Ships - Distribution of	
Personnel	542/44
of Adequate Stocks of Provisions	206/45
Cordite Records on Board H.M.A. Ships	89/44
Equipment of small ships	42/45
Fittings - Upper Deck - H.M.A. Ships	178/44
Gun Armament Material in small ships	51/45
Radar Types 271/5 A.272 Flywood Lanterns	758/44
Malaria Cases - Descriptions of Categories	651/45
- Control - Drafting of Personnel	118/44
- Including the prevention of - Preservation of health -	
General hygiene and sanitation	289/44
- Measures for prevention and control	605/45
- Prevention of spread of	275,520/45
- Supply of Stores for measures for prevention and control	13/44
- With Atebrin - Suppressive treatment (Prephylaxis) for	240/44
Marking and Labelling of Kitbags, Hammocks, Chests and Suitcases	57/45
of Cartridges with Sub-Lot XJ	141/45
- M.Ls.	54/44
Cases, Packages, etc. for Port Moresby	520/45
Packages containing Asdic Stores	798/44
216/44	
Markings - Case - Shipment of Mining Stores	274/45
Marriages - Prevention of Bigamous	546/45
Master-at-Arms - Swords and Belts for	457/44
Mats and Table Cloths	568/44
Meals for R.A.N. Personnel Travelling by Troop Train	370/45
Measuring Tapes - Oil Fuel	174/45
Meat Packs - Embossing of Cans for	526/44
Mechanics - Ordnance and Elstrolial	448/45
Mechanicians - Advancement in Wartime	512/44
Medal Ribbons - Wearing with Tropical Dress	489/44
Medical and Dental Stores - Supply in the New Guinea Area ..	7272/44
Facilities in the New Guinea Area - R.A.N.	
Officers - R.A.N.R. and R.A.N.V.R. - Qualified	
Status	621/44
Attendance of W.R.A.N.S. at Melbourne by a female medical	
practitioner	616/45;572/44

† Denotes C.C.N.O.

Subject

M - contd.

Medical - contd.	
Cabinet - A.M.S. Vessels	442/45
Charges - Rates to be paid for services afforded by	
civilian practitioners	218/45
Examination and Record Form for entry into the Naval	
Forces - Form A.M.6	455/45
of Fairmile personnel - periodical	540/45
prior to draft	120/44
Facilities - use of Army, in transfer of invalids ..	641/44
History Documents of Personnel appointed to or on draft	
to R.A.N. Ships-serving in the Eastern Fleet	7129/45
of the War - Naval	75/44
Observation or Treatment not requiring hospitalisation -	
Despatch of personnel to Sydney for	258/44
Officer - Naval - Port Division - Appointment of ..	622/44
Officers' Journals	527/44
Unmobilised - provision of service uniform	203/45
Organisation in Sydney	62/45
Services - Netherlands East Indies - Directorate of -	
Change of Address	584/45
Status of Personnel recommended to be invalided -	
Introduction of Form A.M.301Z	547/44
Store(s) Account for Scale "C" Medical Stores - Form 177G	222/44
- Scale Base Depot Sick Bays Amendments No.1 and	
No.2	400/44
"C" Amendments No.1 and No.2	401/44
"E" and Coxwains set of First Aid	
Instructions - Booklet - 1944	581/44
Service Afloat - Amendments Nos.1 and 2	598/44
"Sick Quarter" Amendments Nos.1 and 2	401/44
Supply of - Fairmiles, H.D.M.Ls. and Air Sea	
Rescue Boats	44/45
Medicines, Proprietary - Sale of, in Canteens	529/45
Members of the Forces suffering from active Pulmonary Tuberculosis	485/45
Royal Netherlands Navy treated in R.A.N. hospitals	
and sick quarters	299,471/45
W.R.A.N.S. discharged on account of pregnancy	7118/44
Memorandum - Official - Prices of clothing, etc. maintained for	
issue on repayment to ship's companies	285/45,51/44
Memorial Prizes and Testimonials	23/44
Mental Disorder - Certification of members of R.A.N. suffering from	546/44
- Members of the Forces suffering from - National	
Security (Supplementary) Regulations	455/45
Hospitals or Receiving Houses - Admission of Naval personnel	
to	160/44
Merchant Vessels commissioned for Naval service - Accounting for	
consumable Naval Stores in	566/45
Mersigs, Vol.I - B.R.637	553/45
Mess Gear and Blankets - Issue of, to personnel travelling	170,284,552,627/44
-Discontinuance of supply of certain items	10,66,425/45
for W.R.A.N.S. - Amendments to scales	205/45
- Issue of - personnel travelling to or from Darwin by	
the Overland route	154/45
Traps and utensils - Gratuitous replacement of	8/45
- Officers' - Replacement allowances - applicable for	
1942-45	166/45
1944-45	657/44

† Denotes C.C.N.O.

Subject	C.N.O. or C.C.N.O. No.
M - oontd.	
Mess - contd.	
Utensils for Chief Petty Officers', Petty Officers' and Men's Messes - replacement allowances - Applicable for -	
1942-43	152/43
1943-44	661/43
1944-45	665/44
Messages - Concession	514/43
Messing - General - in small ships - installation of ..	626/44
Metal Cap Badges for Ratings - Class III	475/43
Method of Marking Packages - Naval Stores	129/43
Microphotographic X-ray Examinations	329/44
Midshipmen, R.A.N.R. and R.A.N.V.R.	667/43
Military Cloak Room - Adelaide Railway Station	515/45
Defences in Harbour - A.A. Co-operation with	†88/43
Detention Barracks - Uniform and Clothing for Ratings in	356/44
Milne Bay - Shipment of Stores to	405/43
Mine(s) and Bombs - Rendering safe - Organization round the Australian Coast	187,240,276, 309,617/43
- Rendered safe by R.M.S. Parties - Disposal	164/43
- Washed ashore - Awards for reporting	107/43
- Depot, Byford and R.A.N. Armament Depot, Fremantle ..	†89/43
Rendered Safe - Disposal	252/44
Rendering Safe - Employment of personnel other than Officers	251/44
abotage	†54/43
Washed Ashore - Rendering of Reports	45/44
Minesweeping - A.M.S. Vessels fitted for - alteration and addition - Spur for additional Signal Halliards	†118/44
- Use of Iron Sinks	†270/44
Minimum Speeds of ships and depth charge settings for dropping depth charges	9/43
Minol filled depth charges Mk.VII - VII*	106/44
Minor War Vessels - Stowage for firefighting and action repair materials	†179/44
Taken up for War Service	485/44
Misappropriation of Government Stores - Reports to civil police ..	18/43,72/44
Misalignment between engines and propeller shafting	545/43
in M.Ls.	547/44
M.Ls. - Repositioning of depth charge chutes	†152/44
Modification(s) for Listening Watch - Radar Type A.286 P/Q ..	†113/44
- Guns Machine Bren .303" - Boxes Magazine Mk.I	568/44
of Depth charge rails and templates - depth charge equipment	†125/45
Procedure for Accounting for Naval Stores incorporated in W/T, A/S Radar, etc. sets	159/44
R.A.N. pattern haze screens	154/44
- Ratings' Kits	172/45
to Aerial Training System A/SI and A/S3 - Radar Types A.272, A.286 P/Q	†81/44
Bridge Chart Table - Escort Vessels fitted with Radar	†134/44
Catch Piece - Firing Gear - Gun Mounting 4" Mk.XXIII and XXIII*	574/44
Evaporator Systems - H.M.A. Frigates	150/44
and A.M.S. Vessels	†68/44
Fireman and Station 54 - A.M.S. Vessels ..	570/44

† Denotes C.C.N.O.

Subject	C.N.O. or C.C.N.O. No.
M - oontd.	
Modification(s) - oontd.	
to Magazines and Repair Magazine Main Springs - Guns Machine .303" Bren and .303" in Vickers G.O.	394/44
to prevent wrong assembly - Guns Machine .303" in Vickers G.O.	395/44
O.Q.F. 4.7" Mk.XII, XII* and XIIB Breech Mechanisms	579/44
- Method of Securing depth charge chute to dock Motor Launches	†26/44
- Steam Driven Boiler Room fans	195/44
- Type AT5/ARB W/T - R/T set	†80/44
Modified setting stud keys, fuze No.25, Mk.I, I* and II ..	291/43
Monthly Ammunition Expenditure - Returns	224,†271/44
Report of Proceedings	97/43
Morse Operators - Automatic - Visual Signallers, Coders and T/P - W.R.A.N.S. advancement	204/44
Mosquito and Sandfly infested areas - special clothing for ..	168/43
Nets	142/43;215/44
Motor Cars - Allowance for use of private	277/43
Launches - Engine Register	162/44
- Fairmile - Engine Operating hours between Overhauls	344/43
- Modifications to circulating water systems	326/43
- Permissible revolutions	343/43
- Type "B" - slipping of	12/44
- Prevention of fire in	238/43;124/44
- Replacements for Electrical Equipment in	362/44
- Repositioning of D.C. Chutes	†184/44
- Telephones on Bridge	417/44
Patrol Vessels - Klaxon Horns	418/43
Transport Forms	49/44
Vehicles - Naval - accidents	56/44
Mountings - 4" Mk.XXIII and XXIII* - Care in Assembly of Roller Units	610/44
Movements of personnel - reporting and record of	201/43
Musical Instruments - Bugles	509/44
N	
Names - Allocation to Air Sea Rescue Vessels	412/44
Name ships - H.M.A. Shore Establishments	177,629/43;590/44
Naming of A/S. and Radar Maintenance Vessels	†198/44
Special Craft for S.R.D.	†250/44
75 ft. Loop Repair Vessels	†197/44
Napkins - Table and Table Linen - allowances for	317/43
National Security Regulations -	
- Administration of Oaths, etc. to Members of certain Forces ..	322/43
- Delegations and Authorities to Officers holding particular appointments in the R.A.N.	210,375,536/43
- Mobilization of Vessels Order (No.3)	485/44
- Members of the Forces suffering from mental disorder	435/43
- Navigation and Anchor Lights Order (No.3)	345/44
(No.4)	425/44
- Orders	89,210,614/43

† Denotes C.C.N.O.

Subject

N - contd.

Naval Armament and Torpedo Store Account - Errors and Omissions	612/44
Depot, Darwin	†146/44
Gunmounting and Torpedo Stores - Despatch of, to Melbourne	420/45
Store(s) Accounting at certain Shore Establishments - Instructions for	20/45
Accounts - Auxiliary Vessels	75/45
- H.M.A. Ships, etc. - Consumable Stores	585/44
- to be transmitted by registered parcel post	555/45
- in D.E.M.S. - Accounting procedure	515,615/44
Auxiliary Patrol - Concession fares on suburban lines and to and from certain country stations - Victorian Railways	14/45
- Loan Issue of Bluette Combination Suits	36/45
- Personnel - special tropical clothing for	79/45
Base, Darwin - Organization	197,†112/45
Board of Administration	541/44
- Business Member	21/45,105/44
Canteens and Messes - Chocolates and Confectionary for Censorship	158/44
Command - New Guinea Area	25,98,177,651/44
Control Service Officer, Gladstone - appointment of	†67/45
Craft requisitioned - Radios fitted in	†75/45
Dockyard Police - Summer uniform	109/45
- Issue of Chevrons	287,565,404,462/45
Financial Regulations and Instructions - Art.74 - Applications for payment of difference in pay to ratings performing higher duties	190/45
Forces - Form A.M.6 - Medical Examination and Record Form for entry into	565/45
Hospital, Darwin	455/45
Liaison Officer - Australian - Noumea	52/45
Medical History of the War	†55/45
Military and Air Force Club, Adelaide	75/44
Officer(s)-in-Charge	73/44
- Brisbane - Correspondence on Naval Armament Store matters	578/45
- Broome	495/45
- Fairfax	174/44
- Hobart - Mails and Correspondence for	498/44
- New Guinea and Port Directors	†55/45
- Transfer of Headquarters	†55/45
Personnel - Admission to Mental hospitals or Receiving Houses	562/45
- Applications from, for release or leave	597/45
discharge	424/44
- Concession messages	160/44
- Food Coupons	527/45
- in Forward Island Bases - bedding for	205/44
- Interstate rail travel by wives and families of	514/45
- Repatriated - liability for further active service	266/44
- Representations by - Procedure	515/45
- Telephone Trunk Line calls by	524/45
Reserve Depots - Ceremonial Band Instruments	208/44
Officers - Confidential reports on	†41/45
	492/45
	409/45
	257/44

† Denotes C.C.N.O.

Subject

N - contd.

Naval Reserve Officers - contd.	
- Naval Watchkeeping Certificates	256,519/44
- Promotion and confirmation of	301/44
to rank or relative rank of Lieutenant Commander Reserves	559/45
Store Accounting - Documents	555/45
- Procedure - Frigates	244/44
in H.M.A. Shore Establishments - Bedding issued to Chief Petty Officers, Petty Officers and W.R.A N.S.	506/45
- Requisitioned vessels	111/45
Accounts and Accounting - Responsibility of Store-keeping Officers and Personnel	610/45
- Auxiliary Vessels	499/45
- Transfer of charge between storekeeping officers	251/45
Department, Admiralty, in South-West Pacific - Supply Officers of	†62/45
Storekeeping - Replenishment of Stocks of consumable naval stores	271/45
Stores - Accounting for - H.M.A. Motor Patrol Boats and other small vessels in which accounts of consumable naval stores are not required to be maintained	652/45
- Consumable in Merchant Vessels commissioned for Naval Service - Accounting for	566/45
- Ledger Sheets - Amendment of Form A.S.151	246/44
- Custody of	151/45
- Demands for Replenishment of	99/45
- Expended in Naval Works - discontinuance of recovery of cost of material for minor repairs and jobbing from Department of the Interior	404/45
- Interstate and Overseas Shipments and Consignments by rail and air freight to Naval Establishments in Victoria	547/45
Lost by Accident, Neglect or Theft - Procedure	402/44
- Method of Marking Packages	129/45
- Quality of	518/45
- R.A.N. Establishments of	625/44
- Reduction in Establishment Allowances	69/45
- Stowage in A.M.S. vessels	595/45
Navigation Courses	59/44
Navigation Courses to qualify for command of an A.M.S. - R.A.N.V.R. Officers	228/44
Navy, Army, Air Force Club of Victoria - Honorary Membership	609/44
Orders - Confidential Commonwealth - Issue of	196/45
- Issue of	1/45
Vehicles - "Knock for Knock" Agreements	108,445/45
Need for greater use of prefixes "Basegram" and "Deferred"	†2/45
Netherlands - Expenditure on behalf of - classification	187/44
Nets, mosquito	145/45;212/44
Neutral Countries - Prisoners of War and Personnel interned in - Pay and Allowance	469/45

† Denotes C.C.N.O.

Subject

C.N.O. or
C.C.N.O. No.

N - contd.

New Construction - Equipment and fittings	451/43
Guinea Area - Naval Command	787/43
Next-of-Kin particulars - insertion in September Quarter Ledger	385/43;476/44
Night Vision - Classification by A.R.L. Adaptometer (Mark III)	345/44
- Dark Adaptation - Supply of Dark Adaptation	
Goggles	†164/43
Nomenclature of Fuel Oils	474/43
Non-substantive acting rates for V/S I and W/T I - Granting of	239/43
Recommendations for	367/44
Northern Bases - Ammunition supply to	†145/44
- Personnel serving at	150/44
Operational Bases - Stores consigned by sea or air	
freight to	167/44
Noumea - Australian Naval Liaison Officer	†53/43
Numbers claimed for victuals in Provision Account with Ship's	
Ledger - Reconciliation of	283/43
Nurses and W.R.A.N.S. Officers - Agreement for supply of uniforms	
for	222,350/43

O

Oaths, etc. - Administration of, to members of certain forces -	
Regulation 63 of the National Security (Supplementary) Regulations	322/43
Observation and controlled mining parties - badges for	96/43
Oerlikon Ammunition outfits for D.E.M.S.	†58/43
Barrels - Fitting of Spare 20 m.m.	572/43
Guns	525,656/43
- Ammunition for - Pools maintained at ports and	
outfits to be supplied	†5/43
and Mountings	593/44
- Housing - fitted with Mk.XIV Gyro Sights	254/44
Machine Guns - 20 m.m. - Care and maintenance of	121,220/43
- Gauge Striker Protrusion and	
High Diameter Mark I	395/43
- Handbook and Drill for,	
B.R. 274/41 - Amendments to	
Drill	371/43
- Modification of Shoulder Rest	290/43
- Spare Parts	†28/43
- Spring Barrel Mk.II	585/44
- Tool Loading Magazine -	
Introduction	123/43
20 m.m. Guns - Adaptor for American Rods - Cleaning and	
Ejecting - Introduction	505/44
H.E.Lot H.N.C. 13 - Withdrawal	309/44
N.F.E.404 - Ammunition - Withdrawal	310/44
T.P.C.746 - Ammunition - Withdrawal	487/44
Tracer Lot N.F.H.2257F - Ammunition -	
Withdrawal	307/44
10B/45 - Ammunition -	
Withdrawal	308/44
- Locking of Barrels	349,465/44
- Mks.II and IV - Collapse of Barrel Springs Mk.I	350/44
- One Man Cocking Device	261,586/44
- Spares, Appurtenances, etc. - Basic Sets	530/44
Offences committed by ratings on passage to and before joining	
H.M.A.S. "Melville"	83/44
† Denotes C.C.N.O.	

Subject

C.N.O. or
C.C.N.O. No.

O - contd.

Office Machinery - Annual Census	22/44
Machines - Method of Packing	168/44
Officers and Ratings - Waterproof Coats	391/43
- Blankets (Naval Stores) Lost by Neglect - Charges for	232/43
- Cap Badges	45,244/43
- Carrying out duties of gunners - working suits	484/44
- Confidential Reports on	427/44
- Dress	†30/44
- Executive - Radar Courses for	†115/44
- Mess Traps - Gratuitous replacement of	8/43
- Replacement allowances applicable for	
1942-43	166/43
1943-44	660/43
- Naval Reserve - Confidential reports on	257/44
- Naval Watchkeeping Certificates	256,319/44
- Promotion of, to rank or relative	
rank of Lieutenant Commander Naval	
Reserves	359/43
of Special Branch - Alteration to lacing of Jackets,	
Greatcoats and Tunics	382,458/43
- Prisoners of War - Promotion	426/44
- Radar	†26/43
- Rehabilitation - Appointment and Instruction	213/43
- Procedure in regard to invalided	
personnel	356/43
Travelling with a minimum of baggage - special uniform	
grant to	139/43
- Uniform - supply of	169,233/43
- Warrant, appointed in lieu of those who have passed	
Advanced Gunnery Course - Non-specialist Allowance	214/43
Official Memorandum - Prices of clothing, etc. maintained for	
issue on repayment to Ships' Companies	285/43
- Amendment	31/44
Oil Fuel - Burning of	293/43
Measuring Tapes	270/43
- Monthly Report of consumption of, by A.M.S. Vessels	237/43
- Naval Stocks in Australia	†15/44
- Supplies of, to H.M.A. Ships from Naval Commercial	
Oil Fuel Installations	387/43
- Lubricating - for Hall Scott Engines	378/43
- H.M.A. Ships "Kybra", "Wilcannia" and "Reserve"	109/44
Oilers - Fleet Attendant - use by Torres Strait Pilots	†70/43
Oilskin Anti-Gas Clothing - Upkeep and Repair	21/44
Clothing and Rubber Sea Boots - Storage of	530/43;245/44
Ointment and Anti-Gas Eye Shields - Revision of Allowances	209/44
One and Two Piece Combination Suits - cutting of sleeves	370/43
Operating Tables	278/43
Operators - Teleprinter	62,271/44
Optical Instruments - Service and Lookout - Handbook on -	
B.R. 797 - "1943" - Amendments	340/44
O.Q.F. 2-pdr. XIV - Gauges to be maintained at Bases	654/43
4-inch Mark XVI*	122/43
Gun - Extractors	†11/44
40 m.m. Bofors - Locking of Screws, Securing Bracket	
Supporting Buffer - Fitting of Shock-	
proof Washers	466/44
- Mk.I of Australian Manufacture - Springs	
Striker Breech Block - Examination	567/44

† Denotes C.C.N.O.

Subject	C.N.O. or C.C.N.O. No.
O - contd.	
Oral Specialist - Consulting to R.A.N.	161/45
Orchestral Bank Instruments - Percentage charge and grants-in-aid	197/44
Orders under National Security Regulations -	
Immobilization of Vessels Order (No.3)	485/44
Navigation and Anchor Lights Order (No.3)	545/44
(No.4)	425/44
Protection of Shipping (Accommodation for Defence Purposes)	
Order	614/45
Registration of Small Vessels	89/45
Regulation 55 of National Security (General) Regulations ..	89/45
Wireless Stations Control Order - Revocation of certain directions thereunder	395/45; 80/44
Ordnance and Electrical Mechanics	651/44
Branches	82/44
Artificers (O) - for duties in connection with repair and maintenance of Optical Instruments - Introduction of rating	72/45
- B.L. - Care of Obturator Seatings and Pads	685/44
- Q.F. 40 m.m. Bofors - E.F.C. Valves	578/44
- Liquid in Recoil Buffers	375/44
197/45	
Organization - Darwin Naval Base	
- Rendering Mines and Bombs safe - round the Australian Coast	240,276,509/45
Oscillator Unit - Local - Radar Set A272 Mark I	†79/44
Oscillators - Particulars re	†17/45
O.U. 5409 - "Rate Book for Naval Stores"	261/45
Outfit Gratuities on change of class of uniform	548/45; 250/44
- Tropical Outfit - Officers	77/45
- Sydney	297,476/45
Payable on promotion from commissioned Warrant Officer or Warrant Officer - Lieutenant (Emergency or Retired List)	211/44
Hypodermic, individual Morphine Sulphate Gr. 2 or Omnopon Gr. 2/3 (Tubunic Ampoule or Syrette)	379/45
Outfits - Confidential of Tools - R.M.S. and B.S. Organization Overseers, Principal Naval Overseers and Inspecting Officers - Directions for	569/45
"Overtime and Extra Payment" - Form T.406	572/45
Oxy-Acetylene Welding and Cutting Equipment	456/44

P

P.A.C. and Snowflake Rockets - Precautions when carrying out practices or demonstrations	52/44
Projectors - A.M.S.	†151/44
Rocket failures	6/44
Rockets - A.M.S. Vessels	88/44
Packages containing Asdic Stores - marking	†98/44
Packeted Bone-out Beef	671/45
Packing for Auxiliary Machinery - A.M.S. Vessels	415/45
of office machines - method	168/44
Paid Acting Non-Substantive Ratings - condition of award by Captain	586/45
Paint Brushes - Care of - Economy in Bristles	548/45
- Types to be used for Interior Painting - Reduction of Fire and Smoke Risks in H.M.A. Ships	569/44

† Denotes C.C.N.O.

Subject	C.N.O. or C.C.N.O. No.
P - contd.	
Painting and Drawing Schools Victoria	158/45
D.E.M.S. Gunnery Equipment	550/44
- External and Camouflage - standardization of colour shades and introduction of A1 and A2 Class qualities paint	400/45
of Haversacks - Anti-Gas Respirators	582/44
Parallel running of steam driven generators in A.M.S. Vessels	54/45
Paravane(s) - Losses by Merchant Vessels - action by D.E.M.S.	
Staff Officers	76/45
- Replacement or Repair - facilities at Australian ports	†118/45
- Towing Ropes - Defensively equipped Merchant Ships	6/45
Particulars re Oscillators	†17/45
Passages to Australia for dependants of members of the Forces who have married abroad	600/45; 592,576/44
Passports for wives and fiancées - service personnel overseas	157/44
Patrol Channel Boat "Egeria" - Change of name	256/45
Craft - Explosive charges in	†99/45
Vessels - Motor Klaxon Horns	418/45
Pattern VI Targets - Replacement by "Excellent" Pattern ..	657/45
172 Lamps for 20-inch Signalling Projectors - maintenance	†181/45
474 Stretcher Cots - Supply	245/44
1900A - Binoculars	55/45
1957 - Web Equipment	157/44
Pay Accounts and Service Certificates of H.M.A. Ships attached to Eastern Fleet	57,440/44
Ship's Ledger	467/44
and Allowances - Prisoners of War and personnel interned in neutral countries	469/45
- Arrangements - Liaison between Naval and Air Force Officers	141/44
- Deferred - Mobilized personnel	27/44
- On Transfer to another arm of the Services	225/45
- Difference of - Electrical Artificers, Ordnance Artificers and Shipwrights	248/45
- Special Rate for Warrant Officers	561/44
Paying Off - H.M.A.S. - See H.M.A.S.	
Paymaster Lieutenant-Commander - Examination for rank of ..	212/45; 202/44
Sub-Lieutenant-Aotting - Promotion from the lower deck	496/45
Payment of Allowance - Higher Fire Control	180/45
Contractors' claims in connection with funerals	555/45; 250/44
Dependant Allowance - "Dependent Female" - Formerly termed "de facto wife"	668/45
Fares of relatives attending funerals of deceased service personnel	274/44
Piloting of H.M.A. Ships and Vessels	†151/45
Traders' Account for Supplies to H.M.A. Ships	554/45
Penicillin	355/44
- Care and Custody of	497/44
Percussion Detonators - Watertight, Mark VII Lot 141, B.R. 8/41 - Withdrawal from service	41/44
Fuzes D.A. No. 250 - Marks to be used for guns in twin mountings	†65/45
Periodical examination of explosives in shore establishments other than Naval Armament Depots	487/45
Permissible revolutions - Fairmile Motor Launches	545/45
Personnel appointed or drafted to R.A.N. Ships serving in the Eastern Fleet - Medical History - Documents of	†129/45
at sea - Emergency ration for - supply of water bottles	156/44

† Denotes C.C.N.O.

Subject

C.N.O. or
C.C.N.O. No.

P - contd.

Personnel - contd.		
- Awards and Honours to Naval	12, 83, 211, 355, 494/43; 200, 288/44
- Deaths from Disease or Injury - information to be forwarded	229/43
- Deceased - Cremation of	323/44
- Letters found amongst effects of	36/44
- Storage of effects of	640/44
- D.E.M.S. - Liability for Pay etc.	159/43
- Despatch of, to Ships and Establishments in the New Guinea Area	450/44
- Sydney for Medical Observation	258/44
- Discharged - Clothes rationing	118/43
- Rehabilitation Procedure for	14/44
- Distribution of - Maintenance Bases on Shore and Repair Ships	542/44
- Drafting - Malaria Control	118/44
- Employment of, other than officers - rendering mines safe	251/44
- For Discharge - Applications from	205/44
- Found Medically Unfit - drafting categories	24/43
- In Forward Island Areas - special clothing issue for	625/43; 224, 282/44
- Naval - Food Coupons	266/44
- Liability for further active service	206/44
- Release of	608/44
- Procedure in regard to invalided - Rehabilitation Officers	356/43
- Record of and reporting movements of	201/43
- Half-yearly reports on A/S equipment	†148/44
- Release of - for the dairying industry	304/44
- Representations by Naval - Procedure	†41/43
- R.M.S., for Service Afloat	158/44
- Sentenced to detention	5, 341/43
- Serving at Northern Bases	321/44
- Suffering from Mental Disorder - Certification	2/43
- Technical information - promulgation to	3/43
- Training of - Asdic installations Types 144/5	†70/44
- Travelling by train - damage to railway property and accidents sustained by members of the services	200/43
- Troop Train - Meals for	368/44
- Issue of Mess Gear and Blankets to	170, 552/44
- To or from Darwin by the Overland route - Issue of gear	37/44
- Unclaimed effects of	216/43
Petty Officers - R.A.N.R. - Advancement to Chief Petty Officer	290/44
Photographic material for use in H.M.A. Ships and Establishments	8/44
- Records of H.M.A. Ships	641/43
Photographs for Intelligence purposes	147/43
Photography - control of cameras - use in Northern Territory and other Advanced Bases	456/43
Pillar Box Mountings - Failure of 2" U.P.	377/43
Pillow Slips and Sheets - Conservation of	215/44
Pilotage - Payment to H.M.A. Ships and Vessels	†151/43
Pilots - Torres Strait - Use by Fleet Attendant Oilers	†70/43
Pioneers' Tools for Landing Parties	558/43

† Denotes C.C.N.O.

Subject

C.N.O. or
C.C.N.O. No.

P - oontd.

Pistols - Depth Charge - Diaphragms I.R.St.No.6067	- Precautions	267/43
	- Test of "Safe" Positions	419/43
- Mark(s) VII - IX - Locking Screws	124/43
- VII - Restrictions on Issue	415/44
- VIII* - Distribution	†12/43
- VIII* - VIII**	†10/43
- (M) Type B - B* - Introduction of "Klingerite" Washers	441/43
- Routine Tests	421/43
- Thrower - Spares (A.F.O.1954/43)	501/43
- Issue to D.E.M.S., etc.	†194/44
M.L. 9.5 in. Depth Charge Thrower Mk.II - Use of Correct Description	532/44
- Revolver - Losses of	18/44
- Method of Consignment	337/44
- Puff Shots	519/44
Pitting in Engine Room Bilges - A.M.S. Vessels	†69/44
Plague	†207/44
Plates - Earthenware	81/43
Plugs Fusehole 2" Nos.11 and 14 - Return of	678/43
P.M.G. Certificates - Eligibility of Telegraphist Ratings for exemption in certain subjects of the examination for	75/44
Polarized Sun-Glasses - Replacement by Pattern 4074 Anti-Glare Spectacles	125, 281/44
Police - Civil - Reports to - Misappropriation of Government Stores	72/44
- Force - Engagement of Service Personnel	644/44
- Naval Dockyard - Summer Uniform	462/43
Port Adelaide - Refit of A.M.S. Vessels at - replenishment of Naval Stores	34/44
Port Directors	425, 514, 540, 678/44
- and Naval Officer-in-Charge, New Guinea	597/43
- Moresby - Marking of Cases, Packages, etc.	320/43
- Ship's Water Supply at	363/43
Postal Articles - Treatment of Undeliverable	351/43
Postmen and Orderlies - Correspondence	239/44
Powder - Bleaching Powder for H.M.A. Establishments - under conditions of actual gas warfare in Australia	†165/43
Powers of arrest under the National Security Act, 1939-1943 - Exercise of	22/43
Practice Expenditure - Depth Charges	†122/44
Practitioners, Civilian - Rates to be paid for Services afforded by - Medical Charges	218/43
Precautions when carrying out practices - demonstrations with P.A.C. and Snowflake Rockets	52/44
- in hot climates - depth charges	75/43
Prefixes "Basegram" and "Deferred" - Need for greater use of	†2/43
Preservation of Health - General Hygiene and Sanitation - including the prevention of malaria	269/44
- Tools	125/43
Press Advertisements	294/43
- Communications with	133/44
Prevention of Bigamous Marriages	274/43
- Deterioration of kits in Northern Areas	443/43
- Fire in Motor Boats	238/43
- Spread of Malaria	275, 520/43
- X-Ray Burns	456/43

† Denotes C.C.N.O.

Subject	C.N.O. or C.C.N.O. No.
P - contd.	
Prices of Clothing, etc., maintained for issue on repayment to Ship's Companies	285,575/43
- Amendments of Official Memorandum	51/44
Primers Depth Charge, Mks.VII and VIII and Type "M"	654/44
Direction for	569/43
Printed Forms	515/44
Prisoners of War and Personnel interned in Neutral Countries - Pay and Allowances	469/44
Officers - Promotion	426/44
Private Firearms	229/43
Procedure in regard to invalided personnel - Rehabilitation Officers	356/43
- Representations of Naval personnel	†41/43
Professional examination - Warrant Electrician, R.A.N.	370,602/43;500/44
Engineers and Warrant Mechanics	286/43;554/44
Writer and Warrant Supply Officer	555/44
Promotion and Confirmation of Naval Reserve Officers	501/44
from Lower Deck - Acting Paymaster Sub-Lieutenant	496/43
of Naval Reserve Ratings to Warrant Rank	499/44
- to Temporary Warrant Rank	119/44
Warrant Writer and Warrant Supply Officer - Conditions	289/44
Propellant - Flashless	†144/44
Propeller Shafts - A.M.S. Vessels	†62/44
Propellers and Tailshafts - Base Spares	571/44
Prophylactic Centres - control of venereal disease	†152/44
Outfits	†114/43
Prophylaxis - Tetanus	87/44
Proprietary Medicines, Sale of, in Canteens	529/43
Protection of L.L.Sweep Switchboards - A.M.S. Vessels fitted with L.L.Sweeping Equipment	25/43
Shipping (Accommodation for Defence Personnel) - Order and Authority thereunder	614/43
Protective Clothing	251/44
For Fire and Repair Parties	280/43
Goggles for Sun Sector Lookouts - Introduction	459/43
Loan Clothing for H.M.A.Boom Depots	549/43
Provision - Life Saving Appliances	492/43
Provisions - Accounts for - Necessity for prompt payment	217/44
- Canned - Warranty Period of	68,255/44
- Fresh - Contract Rates at Melbourne	101/44
- Supply of, at Melbourne and Sydney	194,511/43
- Maintenance of Adequate Stocks	206/43
- or other Victualling Stores - Report or Survey - Form A.S.330 - Rendition of	127/44
- Revised Fixed Issuing Price List for	565/43
- Supplementary Fixed Issuing Price List for Supplied to Tenders when Absent from Parent Ship - Accounts for	585/44
- Warranted	128/43
Ptergium - Candidates suffering from, to be medically rejected	544/43
Pulmonary Tuberculosis - Active - Members of the Forces suffering from	485/43
Pumps - Reciprocating - Shuttle Valves - Heat Treatment	107/44
- Stirrup - Care of Rubber Hose	142/43

† Denotes C.C.N.O.

Subject	C.N.O. or C.C.N.O. No.
P - contd.	
Purchase of Naval Stores - Introduction of Form A.S.1352 in R.A.N. Shore Establishments and Base Depots	609/43;419/44
Wreaths	364/43
Pyjama Suits	615/43
Pyrotechnics and Rockets, Signal - Ammunition .. Star Shell - All Calibres - Minimum Range at which satisfactory functioning can be expended	195/44
Q	
Quadruple Carriers, Ammunition Carriers, Shell Quadruple - Transfer to Gunmounting Department	182/43
Qualification(s) - Advancement to Chief Shipwright	522/44
of Specialists	447/43
Qualified Officer "Status" - Full and Modified Grant of Quality of Naval Stores	74,132/44
Quarter Bills - Amendments	516/43
Quarterly Return of Temperatures of Storage of Cordite - Forms S.1147a - non-rendering	189/44
Q.F.4" Mark XVI ^g Guns	†100/44
XIX Guns - Bore Telescopes for	266/43
40 m.m. Bofors - Liquid in Recoil Buffers	269/43
	575/44
R	
Radar Admiralty Type - Components of	†282/44
Warning and Gunnery Control Sets - Maintenance	†294/44
Aerial Type B.AP/H/M - Maintenance	†206,†211/44
YFP - Modifications	†168/44
- Australian Type - Authorized Allowances of Accessories (Teat Equipment)	140/44
- Beacons	†240/44
Control and Radar Plot Ratings - Detailed Arrangements - Reports	545/44
Courses for Executive Officers	†115,†296/44
Equipment - Allocation of	†142/44
- Spares for U.S.N. Type	†55/44
- Escort Vessels fitted with - Modification to Bridge Chart Table	†154/44
in A.M.S. Vessels	†9/44
Instructional Films	†155/43
Maintenance Vessels and A/S - Naming of	†198/44
Observation of fall of shot - communications - Anti-Ship Fire Control	†259/44
Officers	†26/43
Offices - Fire Extinguishers	416/43
- Nomenclature	†225/44
Operators - Care of Eyes	†115/43
Personnel - Standards of Vision	†92/43
Reflector - Euston Reef Beacon	†119/44
School - H.M.A. - Correspondence	441/44
Security	†82/44
Set A.272 Mark I Local Oscillator Unit	†79/44
Sets - Spares for - Particulars required in demands	591/43

† Denotes C.C.N.O.

Subject

R - contd.

C.N.O. or
C.C.N.O. No.

Radar - contd.	
Stores - Custody, Issue and Accounting at Ports other than those at which a Naval Store Office is established	477/45
Test equipment of Australian Manufacture	†241/44
Transponder, Instructions for fitting at R.A.N. Bases - Type 253	†107,†245/44
Type(s) 253	†96/44
271/3, A.272, Flywood Lanterns - Maintenance	†38/44
A.272 Mark I, Improved Valve Type NTA 98	†34/44
Obsolescence of Aerial, Transmitter - Modulator, and Aerial Control Units	†87/44
Modification to Overtravel Switch of Aerial System CPT/M	†210/44
Transmitter Fitting of New Matching Transformer Type V.50744	†195/44
,A286 P/Q - Modification to Aerial Training System A/S 1 and A/S 3	†81/44
282M(5)/M(4)/P/P(1)/P(2), 285, 284M(3)/M(4)/P(5)/-P(4), 285M(3)/M(4)/P(3)/P(4) - Switch Rotary Capacity, Design "E", Pattern - W.3896A Improved Geneva Cross Mechanism	†292/44
- W.3896B - Maintenance	†293/44
A.286 P/Q - Interference with W/T and R/t Reception - Modification for Listening Watch	†48/44
A.286 Q	†113/44
Modification to Oil Seal of BAP/H/M Aerial	†88/44
W/T, A/S etc. Equipment Establishment List	†219/44
Radio Mechanic Branch - Adoption in R.A.N.	511/44
- Advancement to Petty Officer	414/45
- Messing in Small Ships	360/44
Sets fitted in Requisitioned Craft, etc.	501/44
Rafts - Lifesaving - Release of	109,160/45
Rail Accommodation - Adelaide to Melbourne	468/44
Travel Interstate - Wives and Families of Naval Personnel	97/44
Railway Fares - Concession - Service Personnel travelling in Uniform and paying their own fares	524/45
Property, Damage to and accidents sustained by members of the Services - Personnel travelling by train	348/44
Warrants - Exchange of, for tickets	200/45
R.A.N. Accounting Officer, Kilindini	342/45
Armament Depot Darwin - Explosive and Gunwharf Stores for Fremantle and Mine Depot, Byford	†91,249/45
Auxiliary Services, Ratings - Khaki Tropical Clothing	†212/44
Destroyers - Accounts	†89/45
Education Service - Reconstruction Training Scheme	461/45
Establishments of Naval Stores	237/44
Higher Educational Test - Results - October 1942	524/44
- April 1943	155/44
- October 1943	104/45
- April 1944	156,248/44
Pattern Haze Screens - Modification	459/44
Personnel - Honours, Decorations, Awards	154/44
- U.S.N. arrangements for supply of common and other Naval Stores	355/45
† Denotes C.C.N.O.	†105/45

Subject

R - contd.

C.N.O. or
C.C.N.O. No.

Range and Deflection Calculators - "Home Made"	472/44
Tables, Gun and Gun Mounting - O.U. Books and Books of Reference	†68/45
Transmitter from Radar to Transmitting Station	546/44
R.A.N.R. Able Seamen - Allocations of, to General Service and R.A.N.V.R. Officers - Confirmation and Provisional Promotion in time of war	558/45
- Watchkeeping Certificate	256,319/44
Officers - Confidential Reports upon	257/44
- Navigational Course to qualify for Command of an A.M.S.	228/44
- Watchkeeping Certificate	256,319/44
Petty Officers - Advancement to Chief Petty Officer	290/44
R.A.N.R.(S), Officers - Promotion to Sub-Lieutenant	581/45
R.A.N.V.R. Special Branch	224/45
Telegraphists - Advancement of	429/45
"Rate Book for Naval Stores" - O.U.5409	261/45
Rates of Treatment in approved Private Hospitals	305/44
Ratings - Accountant Branch - Temporary Commissions	366/44
- Advancement of, during the War	576/45
- Serving in Small Ships	413/45
- Training in Combined Operations	449/45;221,292/44
and Officers - Waterproof Coats	591/45
- Blue Caps for	191/45
- Claim Forms for Compensation for Total Loss of Uniform - Forms A.S.103y and A.S.103z	242/44
- Coder - Temporary Commissions	414/44
- Compensation for Loss of or Damage to, Uniform and Clothing Articles	204/45
- Controlled and Observation Mining - Badges	7/44
- Convoy Signal	49/45;584/44
- D.E.M.S. Gunnery - Badges	95/44
- Disposal of - after sentence of detention or imprisonment	250/45
- Engine Room - Examination of - Results	198/45
- April 1943	457/45
- September 1943	15,191/44
- March 1944	344/44
- Higher Gunnery - Qualification at Sea	228/45
in Military Detention Barracks - Uniform and Clothing Kits, drafted to Darwin, Thursday Island and New Guinea Areas	356/44
- Free - Issue on Entry	265/44
- Modification	154/44
Made-to-Measure Uniforms - Contract at Adelaide	172/45
Brisbane	257/45
- Metal Cap Badges for Class III	522/45
- Offences committed by - on passage to and before joining H.M.A.S. "Melville"	475/45
- Paid Acting Non-Substantive - Condition of Award by Captain	83/44
Performing Higher Duties - Application for Payment of difference in pay to - N.F.R. & I., Art.74	586/45
- R.A.N. Auxiliary Service - Khaki Tropical Clothing	365/45
- R.A.N.R. - Transfer to the Permanent Naval Forces (Seagoing)	461/45
Recommended for Service in D.E.M. Ships	498/45
- R.N., on loan to the R.A.N. - Disposal of Service Certificates on reversion	65/45
† Denotes C.C.N.O.	190/44

54	C.N.C. or C.C.N.O. No.
Subject	
R - contd.	
Ratings - contd.	149/44
- Selection of, for Divers	
Serving in Northern Areas - Additional Supply of Khaki	170/45
Tropical Clothing to	
Services Reconnaissance Department, Far	
Eastern Liaison Office and Allied In-	607/44
Telligence Bureau - Advancement of	591/44
- Submarine Detector - Selection and Aural Care of	464,571/45;
- Supply	17,172/44
	75/44
- Telegraphist	649/44
Trained in Combined Operations - Advancement of	525/45
- V/S and W/T - Training and Advancement during the war	48/45
- Young Seamen in H.M.A. Ships - Training of	650/44
Rationing - Clothes	185/44
- Bed Linen	285/44
- Food and Food Economy	645/44
Rations - Action	67,445/44
- Emergency - for Aircraft Operating from H.M.A. Ships	496/44
Razor Blades - Safety - Gratuitous Issues of	
Re-arming with 4" XIX Guns on H.M.L.A.XXIII* Mounting - H.M.A.	280/44
Ships	450/45
Recall of Ships' Companies from Short Leave	755/44
Reciprocating Main Engines - Frigates	575/44
Recoil Buffers - Liquid in - Q.F. 40 m.m. Bofors	192/44
Cylinder Liquid - Gun Mountings - Test of	107/44
Pumps - Shuttle Valves - Heat Treatment	
Tool Spring, Thompson Sub-Machine Guns 0.45-in. -	744/45
Instructions for use	587/44
Recommendations for Non-Substantive Rates	97/45
Torpedo Non-Substantive Rates	
Reconciliation of Numbers claimed for victuals in Provision	285/45
Account with Ship's Ledger	7145/44
Reconditioned Q.P. 2-pdr. H.E. H.V. Ammunition	
Record Form and Medical Examination for Entry into the Naval	455/45
Forces - Form A.M.6	201/45
of and Reporting Movements of personnel	298/44
Naval Store Ledger Keepers - Introduction of Form A.S.155x	89/44
Records - Cordite - Maintenance on board H.M.A. Ships	7122/45
Retotifier Units, Patt.No.Aust.A.846	544/44
Red Cross Society - Australian	157/45
Reduction of Mails	
Fire and Smoke Risks in H.M.A. Ships - C.A.F.O.	745/45
2565/42 - Application in the R.A.N.	241/44
Kits in H.M.A. Ships and Shore Establishments	69/45
Reductions in Establishment Allowance - Naval Stores	164/44
Reeving of Becketts - Clips Cartridge No.25	755/44
Refresher Escort Training Organization	210/44
Refrigerating Plant for Cold Room - A.M.S. Vessels	488/44
Refrigerators - Domestic Automatic - Test Lamp for	665/45
Register Sheets for C.B. Form "R"	300/44
Registration - Confidential correspondence	479,579/45
Regulations and Instructions for the R.A.N.V.R.	50/45
W.R.A.N.S.	
- National Security (General) - Navigation and	545/44
Anchor Lights Order (No.5)	215,601/45
Rehabilitation Officers - Appointments and Instructions	14/44
Procedure for Discharged Personnel	

† Denotes C.C.N.O.

Subject	R - contd.
Relatives attending funerals of deceased service personnel -	
Payment of fores	274/44
of Naval personnel - Investigating concerning welfare	669/44
Release or Leave - Applications from Naval personnel for	527/45
of Naval personnel	608/44
personnel for the Dairying Industry	304/44
Relics and Articles of Historical Value	7221/44
Re-naming - H.M.A.S. "Vigilant"	285/44
- H.M.A.S. "Viking"	286/44
Rendering Mines and Bombs safe - Organization round the Australian	187,240,276,
Coast	309,617/45
Safe - Employment of Personnel other than	
Officers	251/44
of Forms S.1148(h), (i) and (j) - Failures of Armament	
Material and Ammunition	294/44
Rendition of Form A.S.288A - "Annual Diving Return"	110/45
Renovation of Gold Lace and other articles made of Gold Bullion	9/45
Repainting of A.M.S. Vessels	110/44
Repair of Cartridge Cases	150/45
Repatriated Naval Personnel - Liability for further active service	206/44
Repatriation benefits for members of the Naval Forces and their	
dependants	615/45
Outpatient Clinic, St.Kilda Road, Melbourne	447/44
Repayment Clothing in Tenders	664/45;492/44
Issues of Materials - Uniform and Clothing supplies	171/44
Replacement Allowances applicable for 1942-43 - Officers' Mess	
Traps	166/45
or Repair - Paravanes - facilities at Australian	
Ports	7118/45
Parts - W/T Equipment of Australian manufacture	475/45
Replacements for Electrical Equipment in M.Ls.	582/44
Replenishment of Naval Stores by A.M.S. Vessels refitting at	
Port Adelaide	34/44
Reporting Mines washed ashore - Awards for	107/45
Movements of personnel and record of	201/45
Reports - Ammunition - 20 m.m., 40 m.m., 2-pdr. - 20 m.m.	
Oerlikon H.E. - Withdrawal of certain Lots	142/44
- Confidential, on Naval Reserve Officers	257,427/44
- Firefighting Equipment Trials	161/44
- Half-yearly on Asdic Equipment	719/45
- Record of Personnel	7148/44
- Loss of Gas Cylinders	87/45
of Seasickness - Form A.M.1142	449/44
Stock and Transactions - Guns and Gunmountings	445/44
Survey on provisions or other Victualling Stores -	
Form A.S.550	127,225/44
on Failure of Gun Armament material	500/45
- Periodical Material - Echo Sounding Equipment	716/45
- Rendering of - Mines Washed Ashore	45/44
- Stocks of Ammunition	166/44
- Weekly Stock - Depth Charges and Associated Stores	746/45;747,764,
	772,7155/44
Repositioning of Ballast - A.M.S. Vessels - use of Forepeak -	
Use of after trimming tank	7142/45
Representations by Naval Personnel - Procedure	741/45
Requisitioned Naval Craft, etc. - Radio Sets fitted in	160/45
Ships - Commercial Type Pyrotechnics landed from	588/45

† Denotes C.C.N.O.

Subject	C.N.O. or C.C.N.O. No.
R - contd.	
Requisitioned - contd.	111/45
Vessels - Naval Store Accounting	
- Stores remaining on board on termination of Charter	574/45
Reserves of Depth Charges at Australian Ports and in A.S.I. Ships Gun Ammunition at Australian Ports and in A.S.I.	†57,†66/45
Ships	†6,†100/45
Respirators - Anti-Gas - Containers	†145/45
- Issues to W.R.A.N.S.	†178/45
- Light Type	596/44
- Losses of	553/43
- Painting of Hayersacks	582/44
- Tubes connecting	†75/43
Responsibility of Storekeeping Officers and Personnel - Naval Store Account and Accounting	610/43
Restriction in use - Attache Cases	432/43
Results - Educational Test I - December, 1942	71/45
- March, 1943	272/43
- June, 1943	468/43
- September, 1943	81/44
- December, 1943	203/44
- March, 1944	318/44
- Examination - Engine Room Ratings - November, 1942 - September, 1943	91/43
- Sick Berth Staff - May, 1943	13,191/44
- November, 1943	485/43
- Higher Educational Test - October, 1942	104/44
- April, 1943	104/43
- October, 1943	538/43
- April, 1944	156/44
Retention of Kit on Discharge	459/44
Return of Empty Gas Cylinders	549/43
Stores to Victualling Yards	48/44
Vessels, Lighters, Pontoons, Motor Launches and Boats	188/43
Revised Fixed Issuing Price - List of Provisions	642/43
Revision of Forms A.S. 98 and A.S. 98A	563/43
Revocation of certain orders under the Wireless Stations Control Order	126/43
Revolver, Ball Cartridge S.A. .455" - Mark II Cartridges to be replaced by Mark VI	593/43; 80/44
Pistols - Issues to D.E.M.S., etc.	181/45
- Losses of	†194/44
- Method of Consignment	18/44
Revolvers - Accidents	337/44
R.F.A. "Bishopdale" - fitted for oiling at sea by British Buoyant Hose Method	86/44
Ribbons - Cap	†71/43
- Medal - Wearing with Tropical Dress	299/43
Rifles Aiming 1-in. Elswick "A" Supply for use in 4-in. Mark XIX Guns fitted in H.M.A. Ships	512/44
Inspection of	614/44
"River" Class Corvettes - Reclassified as "Frigates"	551/44
R.M.S. and B.S. Equipment - Afloat	†42/43
Organization - Confidential Outfits of Tools	†15/43
Parties - Disposal of Mines Rendered safe by	†27/43
Personnel for Service Afloat	164/45
Reports on Form S.1516	158/44
	163/43

† Denotes C.C.N.O.

Subject	C.N.O. or C.C.N.O. No.
R - contd.	
R.N. Ratings on loan to the R.A.N. - Disposal of Service Certificates on reversion	190/44
Ships and Authorities - Address of	543/43
Rockets - Apparatus A.D. - Type D - Restriction on Lots 452, 480, 311 and 513	399/43
- Illuminating - 3 $\frac{3}{4}$ lb.	40,676/44
- Failure of	570/44
- Prematures	40/44
- P.A.C. - A.M.S. Vessels	88/44
and Snowflake - Precautions when carrying out practices or demonstrations	52/44
- Failures	5/44
- Target Practice Mark I*, Lots 129 and 144 - Withdrawal - Reports	520/44
2" U.P. Failure	121/44
Roller and Ball Bearings - Procurement	4/44
Rope - Soled Shoes	117/43
for H.M.A. Motor Patrol Boats and Naval Auxiliary Patrol Boats - Loan issue of	88/43
Route Order and Travelling Expense Claim - Form A.S. 542	155,435/43
Royal Australian Naval Volunteer Reserve - Regs. and Instrns. for Women's Services - Uniform and Clothing Authorized Kit	479/43
	375,424,612, 633/43; 55,103, 128/44
Nursing Service - Wearing of Shoulder Straps	175/44
Netherlands Navy in Australia - Telegrams for	50/44
South Yarra Tennis Club, Melbourne - Honorary Membership for Officers	112/43
R/T Interference - A/S Equipment in M.Ls.	†61/44
Sets - V.H/F. - Fitting of - Alteration and Addition	†123/43
- Installation of - Intercommunication Mixed Squadrons - Alteration and Addition	†95/43
R.U. Ammunition - Excessive Temperatures of	186/43
Rubber Sea Boots and Oilskin Clothing - Storage of	530/43; 245/44
- Shortage	68/43
Rudders - Fairmile	293/44
"Rushcutter" H.M.A.S. - Organization	102/43

S

Sabotage - Anti-sabotage measures by H.M.A. Ships in Harbour	76/43
Safeguarding of personal money - Form A.S. 25	106/43
Safety Rail - Training - 20 m.m. Oerlikon	7/43
Sale of Proprietary Medicines in Canteens	329/43
Saline (Salt) Tablets	405/44
"Salt" Journal and "Current Affairs Bulletin"	155/43
Salvage Money - Naval - Distribution	551/44
of Condemned Unserviceable etc. Stores - Army Salvage Service	267/44
Sanitation and General Hygiene - Preservation of Health, including the prevention of Malaria	269/44
Savealls under Motor Boat Engines	503/44
S.A. .305" Cartridges - Land Service	230/43
Scale "E" - Chest of Medical Equipment - Accounting Procedure	685/43
Schools - Drawing and Painting - Victoria	138/43
Scientific Section - Tropical	271/44

† Denotes C.C.N.O.

Subject	C.N.O. or C.C.N.O. No.
S - contd.	
Scuttling Charges - Fitting, in Fairmiles, M.Ls. and H.D.M.Ls.	†250/44
Sea Boots and Oilskin Clothing - Rubber - Storage of	530/45;245/44
Sickness - Cases of - Medical Survey on	†137/44
Seamen's Mess Utensils - Gratuitous Replacement of	8/45
Searchers Steel Wire, Pattern 290	430/44
Seasickness - Report of - Form A.M.114Z	449/44
Seaward Defences - Addresses	†22,†60,†110, †150/45;†136/44
Secret and Confidential Books - Instructions for the Account - ing, Custody of, etc.	†170/45
Correspondence - Instructions re Acknow- ledgment, Disposal, etc.	†56/44
- Security of	†99/44
Security Classifications	†205;411/44
Selection of Ratings for Divers	149/44
Senior Naval Officers Beach Unit	647/44
Combined Operations Section	513/44
Serge - Diagonal	552,565/45
Service Afloat - R.M.S. personnel for	287/45
- Definition of - 1939-45 Star - Persons eligible	201/44
Buildings - Terne Iron - use of	651/45
Canteens	165/43
Certificates and Pay Accounts of H.M.A. Ships attached to Eastern Fleet	57,440/44
- Examination of	630/43
- Inspection of	556/43
- On reversion - disposal of - R.N. ratings on loan to the R.A.N.	190/44
Chevrons	475/44
Shafting - Misalignment in M.Ls.	547/44
Shale or Colliery refuse as Ballast in Ships carrying Explosives - Carriage of	158/45
Shell Grabs - 8" Screw Down Type	591/44
Sheets and Pillow Slips - Conservation of	215/44
Shipment of Mining Stores - Case Markings	216/44
Stores to Milne Bay	403/43
Ships carrying Explosives - Carriage of Shale or Colliery refuse as Ballast	158/45
Fitted with "L.L." and "S.A." Sweeps - Care and Maintenance Reports	†81,†127/45
Funds	219/45
- Landing - Infantry - Administration	†117/44
- Ledger and Pay Accounts	467/44
- Library Books - Purchase Prime Limit	225/43
- Supply to small ships	207/43
Log and Deck Log - Instructions for compiling	337/45
Not in Commission	†1/45
- Small - Supply Assistants	482/45
Water Supply at Port Moresby	365/45
Shipwrights, Electrical Artificers, Ordnance Artificers - Difference of Pay	248/45
Shoes - Galley, for Cooks - W.R.A.N.S.	77/44
- Gymnastic for W.R.A.N.S.	19/44
Introduction of Substitute Pattern	662/44
- Rope-soled	117/45
Shore Establishments and H.M.A. Ships - Reduction of Kits in H.M.A. - Name Ships	241/44 177/45;270/44

† Denotes C.C.N.O.

Subject	C.N.O. or C.C.N.O. No.
S - contd.	
Shore Establishments - contd.	
H.M.A. - Payment of Allowance for Charge of Naval Armament Stores	374/45
R.A.N. - Wartime Allowances of Bedding	469/44
Weekly Report of Stock by - Ammunition - Form A.O.52	326/44
Service at Darwin and Thursday Island - Period of	680/44
Short Leave - Recall of Ship's Companies from	558,450/45
Range A.A.Weapons - Eyeshooting Sights	148/43
Shortage of Rubber Sea Boots	68/43
Shorts - Tropical Khaki - Additional Sizes	78/43
Shoulder Straps - Wearing of	175/44
Shuttle Valves of Reciprocating Pumps - Heat Treatment	107/44
Sick Berth Branch - Candidates for Examination for Higher Rating in	64/45
Manuals and Addenda - B.R.888 and B.R.888(1)	676/45
Staff - Examination Results - November, 1942	91/45
- May, 1943	485/45
- November, 1945	104/44
- May, 1944	458/44
Sights - Conversion of Mk.IV (100 knots) to Mk.V (100 knots) and fitting of Mk.III Butt Plate - Lewis Machine Guns .303-in.	552/44
Signal and Cypher Logs - Disposal of	†44/44
Apparatus - Identification - Indicator Loop	†238/44
Card, 1942 - A.B.R.232 - Issue to Ordinary Seamen V/S	288/45
Letters of British Ships	521/45
Traffic	207/44
Signals - Harbour, to denote Air Raid Warnings	†23/45
Skilled Tradesmen - Employment and Hours of Work	65/45
Sleeves and Torches for Inflatable Lifelelts - Life Saving Equipment	212/44
Small Arms and Close Range Weapons - Precautions	467/45
- Establishments for Shore Bases	†20/44
- Life Throwers, Shoulder, Coston - Replacement by Rifles M.L.E. Line Thrower	123/44
- Revolvers - Accidents	86/44
- Rifles and Sub-Machine Guns - Allowances	†158,†262/44
- Tools - Plates, Screw and Taps, S.A.	455/44
Kitbags	258/43
Ships Ammunition Outfit of - Arrangements for Periodical Exchange, Examination etc.	525/44
and D.E.M.S. Ships - Handling Explosives in	397/45
Soda Ash - Use of, in lieu of Soda Crystals	113/44
Southern Cross Club, New York	460/44
Spare Parts supplied, for O.Q.F.4" Mark XVI* - Fitting of	†93/45
Spare Parts - Base for Propellers and Tailshafts	371/44
- Depth Charge Thrower Pistols	65/44
for Radar Sets - Particulars required in demands	591/45
U.S.N. Type Radar Equipment	†33/44
Special Badge - Bomb Disposal Squads	17/45
Branch - Officers of - Alteration to Lacing, Greatcoats and Tunics	458/45
- R.A.N.V.R.	224/45
Clothing for Mosquito and Sandfly Infested Areas	168/45
Issues for personnel in Forward Island Areas	625/45;224, 282,494/44
Issue(s) - Boots to, Ship's Cooks and Officers' Cooks	460/45
- Clothing to D.E.M.S.Ratings - Lifesaving Waistcoats and Torches	505/45

† Denotes C.C.N.O.

Subject	C.N.O. or C.C.N.O. No.
S - Contd.	
Special - contd.	
Tropical Clothing for N.A.P. personnel	79/43
Uniform Grant to Officers travelling with a minimum of Baggage	139/43
Victualling Assistance to Seagoing Ships victualled on the repayment system	444/44
Specialist(s) - Consulting Oral, to R.A.N.	161/43
- Qualification of	447/43
Spectacles and Dentures - Loss through active service	347/43
- Anti-glare - Pattern 4074 - Supply	30,125,281/44
Speeds, minimum, of Ships and Depth Charge Settings for dropping Depth Charges	†9/43
Sperry Commercial Gyro Compass Equipment - Maintenance	31/43
Mark XIV Gyro Compass - Condensers - Follow up Circuit	379/44
- Repeater Bezel Screws	377/44
- Mod.I Gyro Compass - Incorrect fittings of Transmitter connecting Cables	314/44
- Mercury Ballistic Caps	378/44
- Oiling of Upper Vertical Guide Bearing	376/44
Spirit Duplicators - use of Methylated Spirits	407/43
Split Charge Cases, Depth Charges with - Reports required	162/43
Springs - Barrel Mk.I - Collapse of - Oerlikon Guns 29 m.m.	350/44
Mks. II and IV	
Spur for Additional Signal Halliards - A.M.S. fitted for Mine-sweeping - Alteration and Addition	†118/44
Stability - A.M.S. Vessels	†69/43; †177/44
Staff and Training Requirements Division, Navy Office	464/44
Star (1939-45) and South Africa Star and Mention in Despatches Emblem	466/43
- Persons eligible, and definition of "Service" Afloat	201/44
Shell Allowances	†128/44
Pyrotechnics and Rockets, Signal - Ammunition - All Calibres - Minimum Range	195/44
Statements by Service Medical Officers Regarding Benefits after Discharge	482/44
Statutory Rules governing the Administration of Women's Services - R.A.N.	646/44
Steam Drenching arrangements in Engine Room and Boiler Room of A.M.S. Vessels	15/43
Driven Boiler Room Fan Engine - Vibration of - A.M.S. Vessels	†125/44
Steel and Wood Blocks	312/43
Chests for A.M.S. Vessels	417/43, 181/44
Custody of Confidential Books in Fairmiles	21/43
Furniture - Supply to H.M.A. Ships	336, 354/44
Stirrup Pumps - Care of Rubber Hose	142/43
Stocks of Naval Oil Fuel in Australia	†15/44
Taps and Dies - Adoption of Commercial Type for use in H.M.A. Ships and Establishments	367/43
Stop Watches - Reduced Allowances	507/43
Storage of Cordite - Quarterly Return of Temperatures of - Non-Rendering - Form S.1147a	†100/44
Explosives in Buildings other than Magazines and Explosives Stores	569/44
Oilskin Clothing and Rubber Sea Boots	530/43, 245/44

† Denotes C.C.N.O.

Subject	C.N.O. or C.C.N.O. No.
S - contd.	
Store Accounts and Accounting - Naval - Responsibility of Storekeeping Officers and Personnel	610/43
- Naval Armament - Registered Parcel Post	555/43
- Transfer of Charge between Storekeeping Officers	251/43
Auxiliary Vessels	499/43
Storekeeping Ledgers - Naval - Rearrangement	656/44
- Naval - Replenishment of Stocks of Consumable Naval Stores	271/43
Store - Naval - Accounting Procedure - Frigates	244/44
Stores and Equipment returned to Victualling Yards - Condition of	167/43
- Canteen, for H.M.A. Ships	153/43
- Care of	282/43
- When Ships are undergoing repair, etc	553/44
Condemned, unserviceable, etc. - Salvage of - Army Salvage Service	267/44
- Consumable - Naval Armament Score Accounts - H.M.A. Ships, etc.	585/44
- Damage Control - Lockers for	506/44
- Government - Misappropriation of - Reports to Civil Police	18/43; 72/44
- Medical and Dental - Supply of in the New Guinea Area	489/44
- Form A.M. 177G Medical Store Accounts for Scale "C"	222/44
- Scale "E" and Coxswains Set of First Aid Instructions - Booklet - 1944	581/44
- Mining - Shipment of - Case Markings	216/44
- Naval and Defect List Items - Return of	507/44
Armament - Accounting for	383/43
- Gunmounting and Torpedo - Despatch of to Melbourne	45/44
- In D.E.M.S. - Accounting Procedure	315/44
Consumable, in Merchant Vessels Commissioned for Naval Service - Accounting for	566/43
- Custody of	151/43
- Demands for Replenishments of	99/43
- Establishments of	625/44
- Incorporated in W/T, A/S, Radar etc. sets - Modification of Procedure for Accounting for	159/44
- Losses of, from H.M.A. Ships, due to theft during refit etc. at H.M.A. Naval Yard, Sydney	406/43
- Lost by accident, neglect or theft - Procedure	402/44
- Method of marking packages	129/43
- On permanent loan - transfer of	491/44
- Purchases of - Introduction of Form A.S. 135Z in R.A.N. Shore Establishments and Base Depots	609/43; 419/44
- Quality of	316/43
- Reductions in establishment allowances	69/43
- Replenishment by A.M.S. Vessels refitting at Port Adelaide	54/44
- Responsibility as to Custody in Small Vessels	687/44
- Ventilation of - A.M.S. Vessels	†51/43
- Permanent Naval - Combustion Cones for Boilers	91/44
- Radar - Custody, Issue and Accounting at Ports other than those at which a Naval Shore Officer is established	477/43
- Remaining on Board requisitioned vessels on termination of Charter	574/43
- Return of, to Victualling Yards	188/43

† Denotes C.C.N.O.

Subject

S - contd.

Stores - contd.	405/43
Returned to the Royal Edward Victualling Yard	
Shipped, etc. from H.M.A. Naval Store Depots - Despatch of Advance Supply Notes for	642/44
- Discrepancies in	51/44
- Supply of Naval, Naval Armament and Naval Victualling for Naval Drafts	551/43
Transferred from the U.S.Navy to the R.A.N. ..	456/44
- U.S.N. - R.A.N. - Arrangements for supply of common and other Naval Stores	†105/43
- Victualling - Delivered to H.M.A. Ships in a deficient or damaged condition - Accounting for consignments of	256/43
- Demands for	663/44
Economy in use of Forms	255/43
- Non-delivery of, consigned to H.M.A. Ships or Establishments	404/44
Stowage for Firefighting and Action Repair Materials - Minor War Vessels	†179/44
Stretcher Cots - Pattern 474 - Supply	243;535/44
Sub-Lieutenant - Promotion to - R.A.N.R.(S) Officers ..	581/43
- Machine Guns - Thompson 0.45" - Tool Recoil Spring - Instructions for use	†44/43
Submarine Detector Ratings - Selection and Aural Care of	391/44
Submissions to Naval Board by Tenders	94/43
Subsistence of Persons in Civil Gaols	227/43
Sugar - Consumption Outside Territorial Waters	337,553/44
Suitcases and Small Blue Drill Kit Bags - Variations in Kit ..	234/44
- Labelling and Marking of	37/43
Suits - Bluette Combination - Issue to Supply Ratings	648/43
- Brown Dungaree Combination - Loan Issue to Officers ..	58/43;112/44
Summer Uniform - Naval Dockyard Police - Issue of Chevrons ..	190/43
Sun Glasses - Polarized - Replacement by Pattern 4074 Anti-Glare Spectacles	125,281/44
Helmets and Khaki Covers	192/43
Reflecting Device for H.M.A. Ships	53/44
Sector Lookouts - Protective Goggles for - Introduction ..	459/43
Supplementary Fixed Issuing Price List for Provisions	564/43
Supplies of Citric Acid for Canteens	281/43
Oil Fuel to H.M.A. Ships from Naval and Commercial	
Oil Fuel Installations	387/43
- Shortage of - China, Earthenware and Glassware ..	532/43
- Uniform and Clothing	189/43
Supply Assistants for Small Ships	482/43
Branch	587/44
of Anti-Glare Spectacles Pattern 4074	30/44
Bread at Melbourne	551/43
Canteen Stores	283/44
Civilian Clothing to Members of the Naval Forces on Discharge	390/43;214/44
Coal for H.M.A. Ships - Procedure	32/44
Fresh Provisions at Melbourne and Sydney - Contracts for	194,356/43
Liquid Human Serum	85/43
Low Power W/T - R/T Transceiver Installation - Type R.C.8	†30,†35,†87/43; †12,†37/44
Naval Armament, Naval and Victualling Stores for Naval Draughts	551/43

† Denotes C.C.N.O.

Subject

S - contd.

Supply - contd.	
Officers' Uniforms	169,253/43
Rubber - Exhaustion of	296/43
Spectacles - Delegation of authority	297/44
Stores for Anti-Malarial Measures	15/44
Towels in Victorian State Hostels	463/43
Victualling Stores for A.M.S. Vessels, Frigates, Fair-miles, and H.D.M.Ls. on Commissioning	673/43
Officers of the Naval Store Department, Admiralty in the South West Pacific	†62/43
Rating (A.S.) - New Rating	17/44
Ratings	484,571/43
and Junior Writers - Typewriting Experience	172/44
- Issue to - Suits, Combination, Bluette ..	648/43
Suppressive Treatment (Prophylaxis) for Malaria, with Atebrin	240/44
Surface Craft - Attacks by, on Enemy Submarines	†3/43
Surplus Naval Stores at Commercial Yards	584/43
Survey on Provisions and other Victualling Stores - Reports of Form A.S.350	127,223/44
Survivors - Blankets, Duffel Coats and Towels for	508/43
- Issues of Clothing to	529/43
Suspension of Adjustments between War Departments and State Railways	554/43
Inter-Departmental Adjustments in War Time	429/43
Sweepers "L.L." - Security of Floats to Electrodes	†20/43
Swords and Belts for Masters-at-Arms	346/43
- Naval	242/43
Sydney Command	11,537/43
Detention Quarters	487/43

T

Tablecloths and Mats	5;457/44
Table Linen and Table Napkins - Allowances of	317/42
Tables - Operating	278/43
Tablets - Saline (Salt)	403/44
Tails Propelling Rocket U.2" Mark II - Not to be used ..	42/44
Tailshafts and Propellers - Base Spares	371/44
Tapes for measuring Oil Fuel	270/43
Taps, Stocks and Dies - Adoption of Commercial Type for use in H.M.A. Ships and Establishments	367/43
Target Practice Mark I*, Rockets, Lot S.129 and 144 - Withdrawal - Reports	524/44
Rockets 1 lb.	452/43
Targets - Anti-Craft - Kites and Drogues for - Discontinuance of Supply	146/44
Technical Colleges, Melbourne and Sydney - Correspondence Courses at	146/43
Information - Promulgation to personnel	5/43
Telegrams - Christmas and New Year Greetings	604/43
Telegraphist Ratings - Eligibility for Exemption Subjects of the Examinations for P.M.G. and Certificates	75/44
Telephone Trunk Line Calls by Naval Personnel	492/43
Telephones on Bridge - M.Ls.	417/44
Teleprinter Operators	439/43;60,272/44
Telescopes, Bore, for Q.F.4" Mark XIX Guns	269/43

† Denotes C.C.N.O.

Subject	C.N.O. or C.C.N.O. No.
T - Contd.	
Temporary Commissions - Accountant Branch Ratings	566/44
- Coder Ratings	414/44
- Selection of Ratings from the Lower Deck	103,412/43;474/44
Warrant Rank - Promotion to	119/44
Tenders - Submissions to Naval Board by	94/43
When absent from Parent Ship - Accounts for Provisions supplied to	385/44
Terne Iron - use of - Service Buildings	651/43
Test Lamp for Domestic Automatic Refrigerators	488/44
of Recoil Cylinder Liquid - Gun Mountings	192/44
Testimonials and Memorial Prizes	25/44
Testing Equipment, A/S - Fairmiles and H.D.M.Ls.	†74/43
- W/T - R/T Set - Modification	†80/44
Tests - Routine - Depth Charge Pistols	421/43
Tetanus - Prophylaxis	87/44
Text Books - Vocational Training	287/44
The Legacy Club	625/43
Thompson Sub-Machine Guns 0.45-in. - Tool Recoil Spring - Instructions for use	†44/43
Thrower Pistols - Depth Charge - Spares	65/44
Throwers - Depth Charge Mark II - Replacement of	†25/44
Tickets - Exchange of Railway Warrants for	342/43
Time Fuzes No.401 Marks I and IA	153/44
on Board H.M.A. Ships - Annual Percentage landing in War Time	255/44
Mechanical Fuzes returned from Ships - Amendment of C.B. 5065 (N.M.E.R.)	†144/43
Tyres and Tubes - Conservation of	279/43
T.N.T. Charges for Harbour Defence - 5 lb.	†43/43
- Use of Blocks, T.N.T. 8 oz. Signal Mark I	†169/43
Tool Kits for Torpedo Ratings and Wiremen	582/44
Loading Magazine; Introduction - Oerlikon Machine Guns 20 m.m.	125/43
Tools - Compensation for loss of	184/44
- Confidential Outfits of - R.M.S. and B.S. Organization	27/43
- Machine - Co-ordinated use in Australia between the Services	611/44
- Pioneers', for Landing Parties	558/43
- Preservation of	125/43
Torches and Sleeves for Inflatable Lifebelts - Life Saving Equipment	212/44
Torpedo - Acoustic Homing - Counter Measures to - F.X.R. Gear Depot, Fremantle	†120/44
Igniters, Mark XI - Lot 144, Filled SWYN 9/41 - Withdrawal	64/44
- Lot No.217, Filled B.R.12/41 - Withdrawal	155/44
Non-substantive Rates - Recommendations for	97/43
Stores, Gunmounting and Naval Armament - Despatch of, to Melbourne	420/43
Torres Strait Pilots - use of Fleet Attendant Oilers	†70/43
Total Loss of Uniform and Clothing - Compensation for - Ratings	147/44
Towels, Blankets and Duffel Coats for Survivors	500/43
- Supply of, in Victorian State Hostels	463/43
Towing Hawser - A.M.S. Vessels	401/43
Traders' Account for Supplies to H.M.A. Ships, Payment of	534/43

† Denotes C.C.N.O.

Subject	C.N.O. or C.C.N.O. No.
T - contd.	
Training - Chemical Warfare	361/43
of Engine Room Ratings	4/43
Personnel - Acting Installations Types 144/5	70/44
Young Seamen Ratings in H.M.A. Ships	48/43
- Vocational during the war - Correspondence Courses	340/43
Transceiver Installation Type RC.8 - Provision of - Additional Crystal	281/44
Transfer of Naval Stores on Permanent Loan	491/44
R.A.N.R. Ratings to the Permanent Naval Forces (Seagoing)	498/43
Invalids - Use of Army Facilities in	259/44
Transfers from one Branch to another	251/43
Transmission of Confidential Messages in plain language over Teleprinter Channels	†98/43;†153/44
Transponder - Radar - Type 253 - Instructions for Fitting at R.A.N. Bases	†107/44
Transport of Coding Machines and Spare Parts	†24/44
Mails in H.M.A. Ships	525/44
Transportation - Overseas Air	84/43
- Service Personnel Travelling in Uniform	57/44
Travel Concessions in New South Wales for Members of the Forces - Interstate, Rail - Wives and Families of Naval Personnel	50/43;335/44
Travelling and Freight Warrant Books - Disposal of	324/43
by Troop Train - Meals for R.A.N. Personnel	659/44
- Concession Railway Fares of Service Personnel in Uniform and Paying their own Fares	368/44
Expense and Route Order Claim - Form A.S.542	548/44
Warrants - Signatures of Issuing Officers on - H.M.A. Ships	433/43
Treatment in Approved Private Hospitals - Rates of	674/44
of ex-members of the Forces suffering from malaria which did not manifest itself during the member's service	305/44
Serving Members of the Forces at Repatriation Out-patient Clinic, St.Kilda Road, Melbourne	173/44
Undeliverable Postal Articles	447/44
Trials - Gun - Procedure	351/43
Tropical Clothing	58/44
- Khaki - Additional Supply to Ratings serving in Northern Areas	171/43
- R.A.N. Auxiliary Service Ratings	170/43
Dress - Medal Ribbons	461/43
Outfit Wearing Ashore on the Mainland	312/44
Gratuity - Sydney	564/44
- Grant for	297,476/43
Scientific Section	77/43
Trousers - White Duck	271/44
Tubes and Tyres, Conservation of	314/43
Friction - Machine Rocket Signal Mk.IV - Withdrawal	279/43
M.R.Signal - Failures	636/44
Vent, Electric 1-in. I.C.I. manufacture	634/44
Tunics, Drill, with Blue Facings - Shedding of Dye	†153/44
Twelve Pdr. Gun Mountings	665/43;71/44
Twenty M.M. Oerlikon Guns - Care and Maintenance	183/43
Training Safety Rail	220/43
Twin Mountings - Marks to be used for Guns in - Fuzes Percussion D.A.No.250	7/43
Type AT5/AT8 W/T - R/T Set - Modification	†65/43
	†80/44

† Denotes C.C.N.O.

Subject

C.N.O. or
C.C.N.O. No.

T - contd.

Type - contd.	
A272 Mk.I Radar - Obsolescence of Aerial, Transmitter - Modulator and Aerial Control Units	†87/44
253 - Radar Transponder, Instructions for fitting at R.A.N. Bases	†107/44
Typewriter Ribbons and Carbon Paper	427/43

U

Unclaimed Effects of Personnel	216/43
Undeliverable Postal Articles - Disposal of	351/43
Unfitness, Physical, for Service - Discharge from R.A.N. on account of	93/43
Uniform(s) and Clothing - Authorized Kits - R.A.N. Women's Services	375,424,612,633, 645,646,662,675, 683/43;55/44 20,128/44
- W.R.A.N.S.	
for Ratings in Military Detention Barracks	356/44
- Gratuitous Issues to British and Allied Services	661/44
- Issue of, on repayment to personnel of Allied Navies	369/43
- Ratings - Compensation for Loss or Damage to	204/43
- Supplies	189,464/43
- Repayment Issues of Materials	493/44
Grant - Special - to Officers travelling with a Minimum of Baggage	139/43
- Lacing worn by Lieutenant Commanders R.A.N.V.R. ..	127,259/43
- Officers' - Agreement for the supply of - Inclusion of Uniforms for Nurses and W.R.A.N.S. Officers	222,330/43;407, 458/44
- Held for Disposal at Royal Edward Victualling Yard, Sydney	509/43
- Supply of	169,233/43
- Outfit Gratuities on change of class of	548/43;150/44
- Provision of Service - Unmobilized Medical Officers ..	203/43
- Ratings - Deviation from Standard Patterns	461/44
- Made-to-Measure - Contracts for supply of	405,508/44
Private Outfitters - At Adelaide	257/43
Hobart	115/43
Melbourne and Sydney	59,114/43
Perth	116/43
- Summer - Naval Dockyard Police	462/43
- Issue of Chevrons	190/43
United Kingdom - India, Air Mail	363/44
Unmobilized Medical Officers - Provision of Service Uniform ..	203/43
Unserviceable American Ammunition - Disposal of	78/44
Condemned etc. Stores - Salvage of - Army Salvage Service	267/44
Flags and Inglefield Clips - Return to Store	69/44

† Denotes C.C.N.O.

Subject

C.N.O. or
C.C.N.O. No.

U - contd.

Upper Deck Fittings - H.M.A. Ships - Maintenance of	178/44
Use of Army Medical Facilities in Transfer of Invalids	641/44
Form F.A.30 - Naval Armament Store Accounts in Small Craft	295/43
Gas by Enemy - Responsibility for Identification and Procedure for Reporting	†24/43
Reduced Charges for Practice Q.F. 4" Marks XVI - XVI* Guns Union Jack or Australian Flag at Funerals of Members of the Australian Services	†80/43
U.S.N. - R.A.N. arrangements for supply of common and other Naval Stores	568/43
Utensils, Mess for C.P.O.'s, P.O.'s and Men's Messes - Replacement Allowances for 1942-43	†105/43
	152/43

V

Vacancy for Librarian (Female) - Secretariat, Department of Defence, Melbourne	628/43
Vaccination and Re-vaccination	308/43;†248/44
Valedictory - Vice Admiral A.S.Carpender, U.S.N.	24/44
Valve(s) - Improved Type N.T.A.98 for Radar Type A272 Mark I - Shuttle - Reciprocating Pumps - Heat Treatment	†34/44
Vanadium Bearing Petroleum Ashes - Collection from Oil burning Ships	107/44
Variations in Kit - Small Blue Kit-Bags and Suit Cases	521/44
Vegetables - Dehydrated	234/44
Vehicles - Naval Motor - Accidents	175,457/43
Venereal Disease - Control of - Prophylactic Centres	56/44
- Melbourne Area	†132,†222/44
Venner Time Switch L.L. Minesweepers	40/44
Ventilating Fan - Loss of	87/43
Ventilation of H.M.A. Vessels	66/44
Naval Stores - A.M.S. Vessels	454/44
Wardroom Pantries - A.M.S. Vessels	†51/43
Vessels - A.M.S. - see A.M.S. Vessels.	†89/44
- Auxiliary - Naval Store Accounts	499/43
V.H.F. R/T Set - Fitting of - Alteration and addition	†123/43
- A.M.S. Vessels	†117/43
Vibration of Steam-driven Boiler Room Fan Engine - A.M.S. Vessels	†123/44
Vickers Machine Guns .503" - Loss in transit	78/43
On Single A.A. Mountings - Butts for	39/44
Victorian Railways - Concession Fares on Suburban Lines and to and from certain country towns - N.A.P.	14/43
Victory Loan	117,410/44
Victualling Arrangements - Christmas Day 1944	617/44
Assistance - Special - to Seagoing Ships	
Victualled on the Repayment System	444/44
Stores - Consignments of	256/43
to H.M.A. Ships and Establishments - Non-Delivery of	404/44
- Demands for	663/44
- Supply of, for A.M.S. Vessels, Frigates Fairmiles and H.D.M.Ls. on Commissioning	673/43
Yards - Condition of Stores and Equipment returned to	167/43

† Denotes C.C.N.O.

Subject

C.N.O. or
C.C.N.O. No.

V - contd.

Victualling Yards - contd.	
- Return of Stores to	188/45
Victuals in Provision Account with Ship's Ledger - Reconciliation of Numbers claimed for	285/45
Vision - Night - Classification by A.R.L. Adaptometer (Mk.III) - Standards of - Radar personnel	345/44
Visual Signallers, Coders, T/P and Automatic Morse Operators - W.R.A.N.S. - Advancement	292/45
Vocational Training during the War - Correspondence Courses .. - Text Books	204,655/44
Voice Pipe Communication - A.M.S. Vessels - Alteration and Additions	340/45
Voltage Regulation in Auxiliary Minesweeping Vessels fitted with D.G. and S.A. Equipment	287/44
V/S and W/T Ratings - Training and Advancement during the war	†105/44
V/S 1 and W/T 1 - Granting of Acting Non-Substantive Rates ..	†14/45
Non-Substantive Rates	325/45
	259/45
	420/44

W

War Comforts	525/45
Loans - Service Allotments for Continuous Subscriptions to Service - Apprentices	471/44
- Chevrons for	291/44
Warrant Electrician - R.A.N. Professional Examination for the rank of	219/44
Engineer and Warrant Mechanician - Professional Examination for	570,602/45
Officers appointed in lieu of those who have passed Advanced Gunnery Course - Non-Specialist Allowance	286/45;354/44
- Special Rate of Pay for	214/45
Rank - Temporary - Promotion to	361/44
Allowance	119/44
Writers and Warrant Supply Officers - Professional Examination ..	214/45
- Promotion to - Conditions	304/45;353/44
Warranted Provisions	289/44
Warrants for Arrest of Deserters and Absentees	128/45
- Leave Travelling Concession - Issue of	451/45
- Railway - Exchange of, for Tickets	275/45;448/44
Warranty Period for Canned Meats	342/45
Provisions	562/45
Wartime - Advancement of Mechanicians in	68,255/44
Allowances of Bedding - R.A.N. Shore Establishments	448/45
Washers - India Rubber, for Hose Couplings - use of Correct Patterns	469/44
Watchkeeping Certificate - R.A.N.R. Officers	144/45;534/44
Water Bottles - Emergency Water Ration for personnel at Sea - Supply of	256,519/44
Fresh - Supply to H.M.A. Ships	156/44
Pressure Test - Gas Cylinders	658/44
Shore - Use of, for Water Tube Boilers	289/45;295/44
Supply, Ship's at Port Moresby	†161/44
	365/45

† Denotes C.C.N.O.

Subject

C.N.O. or
C.C.N.O. No.

W - contd.

Waterproof Coats - Belts	298/45
- Officers and Ratings	591/45
Watertight Percussion Detonators - Mark VII Lot 141 B.R.8/41 - Withdrawal from service	41/44
Wattle Rod Fenders	280/44
Weapon Maintenance - Admiralty Fleet Orders 1024 and 1025/45	606/45
Weapons - New - Action to be taken on receipt of	618/45
Wearing of Shoulder Straps - Royal Australian Naval Nursing Service	175/44
Web Equipment - Pattern 1957	137/44
Weekly Report of stock by Shore Establishments	328/44
Stock Reports - Depth Charges and Associated Stores	†46/45;†72,†155/44
Weir Type Feed Pumps	504/44
Welding and Cutting Equipment - Oxy - Acetylene	436/44
Safe Operating Procedures	396/44
Welfare Committees	247/45
White Duck Trousers	314/45
Wife "De Facto" - Change of Term	490/45
Wills - Compulsory making off	47/45;220/44
Wireless Stations Control Order - Revocation of direction under	80/44
Wiremen - Ratings - Advancement	136/45;356/44
Wives and Fiances - Passports for - Service personnel overseas	157/44
Women's Royal Australian Naval Services - Calculation of Time - Convalescent Home for - Statutory Rules	597/44
- Uniform and Clothing	284/44
	646/44
	424,612,653,645,646,662,675/45
- Authorized Kit	685/45;20,55,103,128/44
Wood and Steel Blocks	512/45
Wooden Furniture - Replacement by Steel, in Cruisers, Destroyers, A.M.S. Vessels, and "Warrego" and "Swan"	354/44
Working Suits - Officers carrying out duties of Gunners	474/44
Wounds and Injuries by Enemy Action	550/44
W.R.A.N.S. - Bedding for	169,386/44
- Drafting	159/44
- Galley Shoes for Cooks	77/44
- Gymnastic Shoes for	19/44
- Medical Attention	572/44
- Members of - Discharged on Account of Pregnancy	†118/44
- Mess Gear - Amendments to Scales	205/45
Officers and Nurses - Agreement for Supply of Uniforms	222,350/45
Ratings - Badges for	95/45
- Made-to-Measure Jackets and Skirts - Contracts for Supply of	406,628/44
- Regulations and Instructions	30/45
- Uniform and Clothing	575,612,653,645,646,662,675/45;
	20,55,103,128/44
- Visual Signallers, Coders, T/P and Automatic Morse Operators - Advancement	204/44
- W/T Ratings - Advancement	470/45;275/44

† Denotes C.C.N.O.

Subject

C.N.O. or
C.C.N.O. No.

W - contd.

Wreaths - Purchase of	364/45
Writer Junior and Supply Ratings - Typewriting experience ..	172/44
W/T and V/S Ratings - Training and Advancement during the war	325/43
, A/S, Radar etc., Equipment - Establishment List ..	311,502/44
Equipment of Australian Manufacture - Replacement Parts	475/43
Ratings W.R.A.N.S. - Advancement	470/43:273/44
- R/T Set - Type AT5/AR8 - Modification	†128,†176/45
- R/T Transceiver Installation, Type RC.8 - Supply of	
Low Power	†50,†55/45
Testing Equipment for Frigates	194/44
Transmitters fitted for Crystal Control - A.W.A. Type ..	†104/43
1 and V/S 1 - Granting of Acting Non-Substantive Rates ..	259/45,420/44

X

X-ray Burns - Prevention	456/45
Examinations - Microphotographic	329/44

Z

Zinc Sheets and Underwater Protection of Ships and Fittings -	
H.M.A. Ships	517/44

† Denotes C.C.N.O.

LIST OF NAVY ORDERS ISSUED BETWEEN 1st JANUARY, 1939, AND
31st DECEMBER, 1944, WHICH HAVE BEEN CANCELLED.

Cancelled Order	Superseded by	Cancelled Order	Superseded by
<u>1939</u>		<u>1941 - contd.</u>	
39	50/40	103	412/42
50	420/43	113	601/43
85	107/39	127	351/41
96	420/43	129	355/41
158	37/40	133	136/43
159	91/40	134	25/44
		135	393/42
<u>1940</u>		148	103/43
2	249/40	154	239/41
34	332/42	155	366/41
37	132/41	157	234/42
41	38/41	164	380/45
43	321/44	183	334/42
50	305/44	206	136/43
89	342/42	216	551/43
90	155/40	222	380/44
91	23/41	228	103/43
104	282/42	235	612/44
116	612/44	261	334/42
120	39/41	263	212/42
146	283/40	319	342/42
150	393/42	326	429/43
167	61/44	340	410/42
188	250/40	368	410/42
215	578/43		
216	304/42	<u>1942</u>	
228	489/43	2	103/43
232	528/43	18	256/44
240	304/42	28	429/43
243	580/44	38	448/42
250	73/42	47	561/44
257	498/43	60	230/42
275	359/43	75	446/43
301	315/41	82	230/42
		86	230/42
<u>1941</u>		89	446/43
4	64/41	104	339/43
9	362/43	105	609/44
10	513/43	107	230/42
22	601/43	119	265/44
23	232/43	133	342/42
42	355/41	140	612/44
54	232/41	147	518/43
74	305/44	158	446/43
85	345/44	160	332/42
		170	352/43
		177	448/42

Cancelled Order	Superseded by	Cancelled Order	Superseded by
<u>1942 - contd.</u>		<u>1943 - contd.</u>	
183	519/43	†83	†131/43
184	414/43	†86	†118/43
205	305/44	†94	†123/43
219	134/43	†106	†164/44
230 - Part 2(b)		†117	†180/44
(iii)	375/42	118	480/43
- Part 2(q)	210/43	†128	†80/44
239	339/43	†130	†83/44
248	263/43	†131	†36/44
250	480/43	†142	†45/44
282	149/43	145	359/43
283	146/44	†160	†141/44
288	339/43	†174	†141/44
292	263/43	†175	†36/44
293	448/42	†176	†80/44
299	471/43	†179	†71/44
303	149/43	†180	†164/44
304	601/43	217	305/44
321	525/43	226	158/44
352	480/43	245	265/44
357	345/44	246	446/43
358	446/43	263	266/44
360	256/44	284	127/44
361	525/43	315	469/44
375(b)	210/43	331	241/44
385	612/44	355	612/44
389	263/43	360	257/44
394	197/43	392	266/44
398	519/43	412	414/44
435	390/43	446	23/44
440	351/43	449	649/44
446	263/43	480	630/44
449	102/43	497	366/44
451	587/44	503	354/44
453	525/43	519	543/44
461	480/43	521	263/44
		526	425/44
		559	375/44
		576	263/44
		582	414/44
		594	265/44
		674	493/44
		684	560/44
<u>1943</u>		<u>1944</u>	
2	346/44	†2	†117/44
†9	†188/44	10	646/44
23	436/43	†10	†139/44
†25	†20/44	†13	†36/44
†29	†57/43	†14	†71/44
†34	†36/44	†35	†80/44
†36	†83/44	†36	†141/44
40	519/43	59	477/44
41	229/44	†47	†72/44
†46	†72/44		
46	127/44		
†50	†164/44		
56	580/44		
†61	†117/44		
†64	†138/43		
†69	†177/44		

Cancelled Order	Superseded by	Cancelled Order	Superseded by
<u>1944 - contd.</u>		<u>1944 - contd.</u>	
†64	†72/44	221	649/44
†71	†140/44	†224	†271/44
76	278/44	249	543/44
84	543/44	259	641/44
†117	†208/44	270	390/44
135	625/44	292	649/44
†141	†240/44	317	425/44
144	294/44	348	643/44
147	561/44	393	517/44
150	321/44	413	512/44
†175	†280/44	526	631/44
199	425/44		

DEPARTMENT OF DEFENSE
JANUARY

DEPARTMENT OF DEFENCE
LIBRARY.

RESTRICTED.

COMMONWEALTH NAVY ORDERS

I N D E X

OF

NAVY ORDERS

1944

COMPRISING

NAVY ORDERS ISSUED BETWEEN

1st JANUARY, 1943, and 30th JUNE, 1944,

and

LIST OF NAVY ORDERS CANCELLED

SUBSEQUENT TO 1st JANUARY, 1939.

(This Index is published at the end of each half-year.)

Photo-lithographed, by Authority:
H.E. DAW, Government Printer, Melbourne.

I N D E X

Subject	C.N.O. or C.C.N.O. No.
A	
A.A. Co-operation with Military Defences in Harbour	†88/43
Gunfire from H.M.A. Ships in Harbour	†77/43
Machine Guns, Annual Practice Allowance of .303" - Ammunition for	†7/43
Targets - Kites and Drogues for - Discontinuance of Supply	146/44
Weapons, Short Range, Eyeshooting Sights	148/43
Able Seamen - R.A.N.V.R. - Allocation of, to General Service ..	176/44
Abnormal Expenditure - Accumulators	181/44
A.B.R. 232 - Signal Cards - Issue to Ordinary Seamen V/S ..	288/43
A.C.B. 247 (R) Issue	†83/44
Access to Compartments situated below the waterline which are to be manned at sea	233/44
Accidents - Guns	28/44
- Naval Motor Vehicles	56/44
- Revolvers	86/44
- Sustained by members of the services and damage to railway property - personnel travelling by train	200/43
Accommodation - Rail - Adelaide to Melbourne	97/44
Accountant Officer, Inspecting	428/43
- R.A.N. Kilindini Address for mail	†91, 249/43
- Training Course - Selection for	497/43
Accounting for articles purchased from Canteen Funds	649/43
Consignments of Victualling Stores delivered to H.M.A. Ships in a deficient or damaged condition	256/43
Consumable Naval Stores in Merchant Vessels commissioned for Naval Service	366/43
Machinery, Machine Tools, etc. supplied for Naval Workshops	108/44
Naval Armament Stores	383/43
Stores - H.M.A. Motor Patrol Boats and other small vessels in which accounts of con- sumable Naval Stores are not required to be maintained	632/43
Purchases and Issues of Fruit in Provision Accounts of Ships and Establish- ments	301/43
Naval Armament Stores - Small Vessels and Boats	222/43
Procedure in H.M.A. Establishments - Naval Store - Bedding Issued to Chief Petty Officers, Petty Officers and W.R.A.N.S.	506/43
- Naval Armament Stores in D.E.M.S.	315/44
Store - Frigates	244/44
Accounts for Provisions - Necessity for prompt payment ..	217/44
- Naval Armament Stores - To be transmitted by Registered Parcel Post	355/43
Store - Transfer of charge between Storekeeping Officers	231/43
- Pay and Service Certificates - H.M.A. Ships attached to Eastern Fleet	57/44
- R.A.N. Destroyers	237/44
Acid for Canteens - Supplies of Citric	281/43
Acting Leading Stokers - Confirmation and qualifications for Stoker Petty Officer	518, 583/43

† Denotes C.C.N.O.

Subject

C.N.O. or
C.C.N.O. No.

A - contd.

Acting Petty Officers - Irregular wearing of Class III Uniform	106/44
Action to be taken on receipt of New Weapons	618/43
Additional Armament - Gate Vessels and Boom Working Vessels ..	†57/43
Address for mails - R.A.N. Accountant Officer, Kilindini	249,†91/43
of Commander-in-Chief, Eastern Fleet	†90/43
R.N. Ships and Authorities	543/43
Addresses - Seaward Defences	†22,†60,†150/43;†136/44
Adelaide Railway Station - Military Cloak Room	513/43
Adjustments - Inter-Departmental - Suspension in War-Time ..	429/43
Administration - Landing Ships Infantry	†117/44
of Oaths etc to Members of Certain Forces -	
Regulation 63 of the National Security	
(Supplementary) Regulations	322/43
Admiralty Fleet Orders 1024 and 1025/43 - Weapon Maintenance ..	606/43
and Confidential Admiralty Fleet Orders	178/43
Admission of Naval Personnel to Mental Hospitals or Receiving	
Houses	180/44
Adult Education in the R.A.N.	394/43
Advanced Base Ports - Fire Fighting Equipment	512/43
Advancement - Communications Branch	105/43
- Mechanics - In Wartime	448/43
- of Ratings during the War	376/43
- of Ratings serving in small ships	413/43
Trained in Combined Operations	449/43;221,292/44
- of Recovered Deserters to Able Seamen of equivalent rating ..	26/44
- Radar Branch	519/43;84/44
to Chief Rate - Artificers etc.	528/43
Petty Officer - R.A.N.R. Petty Officers ..	290/44
Shipwright - Qualifications	522/44
- W.R.A.N.S. - W/T Ratings	470/43;273/44
Advances - Cash - For Fighting French Warships	†75/44
Advertisements, Press	294/43
Aerial Training System A/SI and A/S3 - Modifications to Radar	
Types A272, A286 P/Q	†81/44
Africa Star, Star 1939-43 and Mention in Despatches Emblem ..	466/43
Agencies - Commonwealth Savings Bank - Commission	85/44
Agreement for the Supply of Officers' Uniforms - Inclusion of	
Uniforms for Nurses and W.R.A.N.S. Officers	220,530/43
Agreements - "Knock for Knock" - Navy Vehicles	108,519/43
Aircraft Operating from H.M.A. Ships - Emergency Rations for ..	67/44
Air or Sea Freight - Stores consigned by - to Northern Opera-	
tional Bases	167/44
Raid warnings, harbour signals to denote	†23/43
Alarm Signals for A.M.S. Vessels	644/43
Allocation of Radar Equipment	†142/44
R.A.N.V.R. Able Seamen to General Service	176/44
Allotments of Members of the R.A.N. who are reported killed,	
presumed killed, missing or prisoners of war	199/43
Allowance - Captain of Heads	238/44
- Dragnets	311/43
- for Charge of Naval Armament Stores - Payment of -	
H.M.A. Shore Establishments	374/43
Use of Private Motor Cars	277/43
- Non-specialist for Warrant Officers appointed in	
lieu of those who have passed Gunnery Course ..	214/43
Allowances of Accessories - Authorized (Test Equipment) for	
Australian Type Radar	†140/44

† Denotes C.C.N.O.

Subject

C.N.O. or
C.C.N.O. No.

A - contd.

Allowances of Table Linen and Table Napkins	317/43
- Star Shell	†128/44
"All Services" Small Arm Ammunition - Accounting for	327/43
Alterations and Additions - Access to compartments situated below	
the waterline, which are to be manned at sea	233/43
Alteration(s) and Addition(s) - A.M.S. Vessels - A.F.O. 389/43	†32/44
- Asdic Installations -	
Fairing of Shell Plat-	
ing C.A.F.O. 2163/43	†102/44
- Fitted for Minesweeping-	
Spur for Additional	
Signal Halliards	†118/44
- Hailing Equipment	
A.F.O. 3963/43	†108/44
- Stiffening of Seat-	
ings - Kelly and Lewis	
Steam driven Gener-	
ators	†104/44
- Voice Pipe Commun-	
ications	†103/44
- Depth Charge Pattern Control Intro-	
duction	†121/44
- Firefighting in H.M.A. Ships A.F.O.	
5393/43	†97/44
- V.H.F. R/T Sets - Fitting of ..	123/43
to Jackets of Petty Officers and Men not dressed as	
Seamen	243/43
- Reduction in Contract Prices	284/43
Amendment to "Official Memorandum - Prices of Clothing, etc. Main-	
tained for issue on repayment to Ships' Companies" -	
dated 1st May, 1943	31/44
of Form A.S.151 - Consumable Naval Store Ledger Sheets	246/44
Amendments to Drill - B.R.274/41, Handbook and Drill for 20 M.M.	
Oerlikon Machine Gun	371/43
- Quarter Bills	189/44
Ammunition - "All Services" Small Arm - Accounting for	327/43
- Ball .303" - Replenishment of Army Stocks at Outports	202/43
- Boxes C222 and C199	2,278/44
- Carriers Quadruple and Carriers Shell Quadruple -	
Transfer to Gunmounting Department	182/43
- For Oerlikon Guns - Pools Maintained at Ports and	
Outfits to be supplied	†5/43
- Practice	323,386/43
- Fuzes, Primers and Tubes - Tubes Vent, Electric 1	
in Mark IV Lots 24, 28 and 35 of I.C.I. Manufacture	
1941	122/44
- Gun Armament Material - Failure of	144/44
- Gun, Reserves of, at Australian Ports and in A.S.I. ships	†6/43
- Miscellaneous A.A.D. Weapons - Rails, Propelling Rocket	
U2 in Mk.II	42/44
- Propelling Rockets	
U2 in Mk.II and	
III, Kirby Lots 32,	
33, 136, 178, 179	
and 182 - Restriction	152/44
- Outfits of Small Ships	325/44

† Denotes C.C.N.O.

Subject

A - contd.

Ammunition - Contd.

- Pyrotechnics and Rockets, Signal - Star Shell - All Calibres - Minimum Range at which satisfactory functioning can be expected	193/44
- Reconditioned Q.P. 2-Pdr. H.E.H.V.	†143/44
- R.U. - Excessive Temperatures of	186/43
- Small Arms - Allowances for Shore Bases	†74/44
- Stock Reports	166/44
- Supply to Northern Bases	†145/44
- Unserviceable American - Disposal of	†78/44
- Weekly Report of Stock	472,589/43
- by Shore Establishments on Form A.O.5Z	
- 20 M.M. Oerlikon - Clearing Charges	151/44
- 20 M.M. and 2-Pdr. - 20 M.M. Oerlikon H.E. - Liability to Caps of Cartridges Blowing Out, when Modified Breech Face Piece (Mark II) are Fitted - Withdrawal of Certain Lots - Reports	142/44
- 20 M.M. Oerlikon H.E. Lot H.N.C.13 - Withdrawal ..	309/44
N.F.E.404 - Withdrawal	310/44
Tracer Lot N.F.H.2257 F - Withdrawal	307/44
10B/45 - Withdrawal	308/44
- .303" for A.A. Machine Guns - Annual Practice Allowance of	†7/43
A.M.S. Vessels - Additional Kit Lockers	†41/44
Ventilation to Galley and Commanding Officer's Cabin	†157/43
- Alterations and Additions	50,106/43
- 389/43	†32/44
- Asdic Installations - Fairing of Shell Plat- ing C.A.F.O.2163/43	†102/44
- Depth Charge Throwers Mark II Replacement by Mark IV - C.A.F.O.1964/43, Paragraph 2 (a)	†86/44
- Fitted for Minesweeping - Spur for Additional Signal Halliards	†118/44
- Fitting of D/F Equipment A.W.A. Type C.143A	†85/44
- Hailing Equipment - A.F.O.3963/43	†108/44
- Lockers for Firefighting and Action Repair Materials	†63/44
- Modification to Auxiliary Steam Line in Boiler Room	†49/43
- Stiffening of Seatings - Kelly and Lewis Steam Driven Generators	†104/44
- Voice Pipe Communications	†103/44
- Anchor Buoys in	622/43
- And Frigates - Modification to Evaporator System	†68/44
- Armament	113/43
- A/S Type 128 or 128A Where Fitted - Conversion to A/S Type 128B or 128C	†139/44

† Denotes C.C.N.O.

Subject

A - contd.

A.M.S. Vessels - contd.

- Canvas Flag Wallet for	114/44
- Contamination of Boiler Feed Water with Oil Fuel	275/44
- Deterioration of Cast Iron Condenser Doors	11/44
- Efficiency of	†48/43
- Fitted with L.L.Sweeping Equipment - Protection of L.L. Sweep Switchboards	25/45
- Fitting of Balance Weights to Crankshaft of Kelly and Lewis Steam Driven Generators	†103/43
V.H/F. R/T Set	†117/43
- Gunnery Communications	†7/44
- Installation of Permanent D.G.	†58,†82/43
- Kelly and Lewis Steam Driven Generating Sets - Governors	310/43
- Landing of Awnings, etc.	361/43
- L.L. 57/5 Cells for L.L. Sweeps	†8/44
- Machinery of - Necessity for Purity of Seawater	86/43
- Modification of - to Steam Driven Boiler Room Fans	195/44
- Monthly Report of Consumption of Fuel Oil	237/43
- P.A.C. Projectors	†151/44
- Rocketts	88/44
- Packing for Auxiliary Machinery	415/43
- Parallel Running of Steam Driven Generators in	54/43
- Fitting in Engine Room Bilges	†69/44
- Propeller Shafts	†62/44
- Radar in	†9/44
- Refrigerating Plant for Gold Room	210/44
- Refit at Port Adelaide - Replenishment of Naval Stores	54/44
- Repainting of	110/44
- Stability	†69,†111/43
- Steam Drenching Arrangements in Engine Room and Boiler Room	†15/43
- Steel Chests for	417/43,†182/44
- Towing Hawser	401/43
- Use of Fore Peak for Trimming Ship	†45/44
- Ventilation of Naval Stores	†51/43
- Wardroom Pantries	†89/44
- Vibration of Steam Driven Boiler Room Fan Engine	†123/44
Anchor Buoys in A.M.S. Vessels	622/43
Annual Census - Office Machinery	22/44
Inspection of Explosives ex H.M.A. Ships	111/44
Practice Allowance of .303" Ammunition for A.A. Machine Guns	†7/43
Anti-Aircraft Targets - Kites and Drogues for - Discontinuance of Supply	146/44
- Gas Clothing - Oilskin - Upkeep and Repair	21/44
- Eyeshields and Ointment - Revision of Allowances	209/44
Respirators - Containers	†145/43
Tubes connecting	†73/43
- Glare Spectacles - Pattern 4074 - Supply	30/44
- Polarised Sun Glasses - Replacement by	281/44
- Malarial Measures - Supply of Stores for	15/44
- Sabotage Measures by H.M.A. Ships in Harbour	†76/43
Apparatus A.D. Type D. Rocketts Mark III - Restriction on Lots 452, 480, 511 and 513	399/43
Testing Adjuster - Modification for Marks XIII A and XIII* Depth Charge Pistols	345/43

† Denotes C.C.N.O.

Subject

A - contd.

C.N.O. or
C.G.N.O. No.

Appliances, Lifesaving - Provision	252/43
Application(s) for Payment of Difference in Pay to Ratings performing Higher Duties - Naval Financial Regulations and Instructions, Article 74	365/43
from Naval Personnel for Release or Leave	527/43
Discharge	205/44
Appointment(s)	316/44
and Instructions - Rehabilitation Officers of Naval Control Service Officer, Gladstone	213/43
73/43	
Apprentices - War Service	291/44
Armament - Additional - Gate Vessels and Boom Working Vessels	†57/44
- Depot, R.A.N. Fremantle and Mine Depot, Byford	†89/43
- Naval Depot, Darwin	†146/44
- H.M.A. Ships - Additional Fitting of	†46/44
- Material and Ammunition - Failures of - Rendering of Forms S1148(h),(i) and (j)	294/44
- Store Accounting Officers	438/43
Accounts, Naval - To be transmitted by Registered Parcel Post	355/43
Matters - Naval - Correspondence on - Naval Officer-in-Charge, Brisbane	174/44
Arms, Small - Establishment for Shore Bases	†20/44
Army Form W.5192 "Duty Free Concessions for Gift Parcels sent to the United Kingdom from H.M. Forces Overseas	444/43
Salvage Service - Salvage of Condemned, Unserviceable etc. Stores	267/44
Arrangements in respect of the Agreement between U.K. and Australian Governments for H.M. Ships transferred to R.A.N. for manning	†51, 227/44
Arrests of Deserters and Absentees - Warrants for	451/43
Articles Duty-free for H.M.A. Seagoing Ships	28/43
Artificers, Electrical and Ordnance and Shipwrights - Difference of Pay	248/43
A/S Dromes - Losses of and Damage to	†18/43
Equipment - Half-Yearly Reports on - Record of Personnel	†148/44
in M/Ls - R/T Interference	†61/44
Sets, Type 128 - Directing Gear	†84/43
or 128A where fitted - Conversion	†10/44
- A.M.S. Vessels - Conversion to A/S Type 128B or 128C	†139/44
Testing Equipment - Fairmiles and H.D.M.Ls	†74/43
, W/T, Radar, etc. Equipment - Establishment Lists	311/43
Asbestos Clothing for Fire-fighting	621/43
Asdic Equipment Half-Yearly Reports on	†19/43
Gear etc. - Precautions to be taken to prevent damage to	
Drydocking H.M.A. Ships	325/44
Installations Types 144/5 - Training of Personnel	†70/44
Recorder Paper Rolls	†55/44
Stores - Packages Containing - Marking	†98/44
Ashes and Garbage from H.M.A. Ships at Outer Harbour and Port Adelaide. Disposal of	313/44
Assessment of Efficiency	120/44
Atebrin - Suppressive Treatment (Prophylaxis) for Malaria	240/44
Attache Cases - Restriction in the use of	432/44
Attacks by Surface Craft on Enemy Submarines	†5/44
Australian Defence Canteens Service Clubs	47/44
Military Forces - Flag of Water Transport Units of	640/44
Naval Liaison Officer, Noumea	†53/44

† Denotes C.C.N.O.

Subject

A - contd.

C.N.O. or
C.G.N.O. No.

Authorities under National Security Regulations -	
Administration of Oaths etc. to Members of Certain Forces	322/43
Entry to Enclosed Wharves	493/43
Protection of Shipping (Accommodation for Defence Personnel) Order	614/43
Authorized Allowances of Accessories (Test Equipment) For Australian Type Radar	†140/44
Kits - Uniform and Clothing - Royal Australian Naval Women's Services	375/43
Automatic Morse Operators and T/P Visual Signallers, Coders -	
W.R.A.N.S. - Advancement	20, 53, 128, 204/44
Auxiliary Minesweeping Vessels Fitted with D.G. and S.A. Equipment - Voltage Regulation in	†14/43
Vessels - Naval Armament Store Accounts of	73/43
Store Accounts	479/43
War Vessels - Magazine Logs	221/43
Awards, Decorations and Honours to Naval Personnel	12, 83, 211, 335/43;
200/44	
Awnings, etc. - Landings of - A.M.S. Vessels	561/43

B

Badge Special for Bomb Disposal Squad	17/43
Badges - Controlled and Observation Mining Ratings	96/43, 7/44
- D.E.M.S. Gunnery Ratings	93/44
- for W.R.A.N.S. Ratings	95/43
- Flying	647/43
- Good Conduct	486/43
- Service, R.A.N.R. - Deprivation and Restoration	61/44
- Metal Cap for Chief Petty Officers and Petty Officers	254/43
- Officers' Cap	45, 244/43
Ball Ammunition .303" : Replenishment from Army Stocks at Out Ports and Roller Bearings - Procurement	202/43
4/44	
Ballast - Carriage of Shale or Colliery Refuse in Ships carrying Explosives	158/43
Band Instruments - Ceremonial - Naval Reserve Depots	409/43
- Orchestral - Percentage Charge and Grants-in-Aid	197/44
Bank Agencies - Commonwealth Savings - Commission	85/44
"Basegram" and "Deferred" Prefixes - Need for Greater Use of	†2/43
Battle Dress	151, 265/43
Beacon(s) - Radar	†141/44
- Euston Reef - Radar Reflector	119/44
Beckets - Reeving of - Clips Cartridge No.25	164/44
Bed Linen - Clothes Rationing	183/44
Bedding for Naval Personnel in Forward Island Naval Bases	315/43
Issued to Chief Petty Officers, Petty Officers and	
W.R.A.N.S. - Naval Store Accounting Procedure in	
H.M.A. Shore Establishments	506/43
W.R.A.N.S.	169, 218/44
Belts and Swords for Masters-at-Arms	346/43
- Waterproof Coats	298/43
Bicycles - Losses of	426/43
- Departmental - Branding of	611/43

† Denotes C.C.N.O.

Subject

B - contd.

Bigamous Marriages, Prevention of	274/43
Bilges - Fitting in Engine Room - A.M.S. Vessels	†69/44
Bills - Quarter - Amendments	189/44
Binoculars - for D.E.M.S.	232/44
- Pattern 1900A	35/43
- Temporary Reduction in Full Approval Scales of Allowances	423/43
"Bishopdale" R.F.A. - Fitted for Oiling at Sea by British Buoyant Hose Method	†71/43
Blankets and Mess Gear - Issue to Personnel Travelling	170,264/44
- Duffel Coats and Towels for Survivors	500/43
- for Loan Issue - Prices for Losses by Neglect	59/43
- Officers' (Naval Stores) Lost by Neglect - Charges for Bleaching Powder for H.M.A. Naval Establishments under conditions of Actual Gas Warfare in Australia	†165/43
Blocks - Steel and Wood	312/43
Blue Caps for Ratings	191/43
Trousers - Alternative types	37/43
Blouette Combination Suits - Loan Issue of - N.A.P.	36/43
Board of Trade Certificates - R.A.N. Officers	306/43
Bofors - 4 m.m. Gun Mountings	559/43
- Guns - Care and Maintenance	163/44
Boiler Tube Cleaning Apparatus - Flexible Shafting for Feed Water - Contamination of by Oil Fuel - A.M.S. Vessels	15/43
Boilers - Combustion Cones for - Permanent Naval Stores	275/44
Bolts Gunmounting - Holding down	91/44
Bomb Disposal Squads - Special Badge	184/43
Bombs and Mines, Rendering Safe - Organization round the Australian Coast	17/43
Books and Forms	187,240,276,309,617/43
	19,29,38,61,82,100,208,260,
	302,318,350,373,408,434,478,
	510,568,650/43;55,78,102,129,
	185,198,247,268,299/44
- Ships' Library - Purchase Price Limit	223/43
- Supply to Small Ships	207/43
Boom Defence Depots - Darwin, Fremantle, Sydney and Brisbane	277/43
- Establishments of, at Cairns, Townsville, Port Kembla and Port Moresby	58/44
Working Vessels and Gate Vessels - Additional Armament	†57/43
Bore Telescopes for Q.F. 4" Mark XIX Guns	269/43
Boots - Football	550/43
- Rubber Sea - Oilskin Clothing - Storage of	530/43;245/44
Boxes Ammunition C.222 and C.199	2,278/44
Complete Tools and Spare Parts, Marks IV and IV** Pistols - Boxes Complete Testing Sets, Marks IV and IV** Pistols	43/43
For Gas Cylinders	619/43
Magnetic Compasses - Return when Empty	454/43
B.R.637 - Mersigs Vol.I	353/43
274/41 - Handbook and Drill for 20 m.m. Oerlikon Gun - Amendments to Drill	371/43
Branch-Coding	339/43
- Pass Professional Examination	60/44
- Re-examination of Ordinary Coder	16/44
Special R.A.N.V.R.	224/43
Branches - Ordnance and Electrical Mechanic	82/44
Branding of Departmental Bicycles	611/43

† Denotes C.C.N.O.

Subject

B - contd.

Bread - Supply of, at Melbourne	551/43
Bren Machine Guns - .303" Mark I - Springs, Return Mark II	185/43
Bridge Chart Table Modification to - Escort Vessels fitted with Radar	†134/44
Bristles, Economy in - Care of Paint Brushes	348/43
the use of - Discontinuance of Purchase of Pattern C.280 and C.281 Sash Tool Brushes during Hostilities	658/43
British - U.S. Communications - Flags	557/43
B.S. and R.M.S. Equipment - Afloat	†13/43
Organization - Confidential Outfits of Tools	†27/43
Burials, Graves, Registration, Identification of Bodies and Burial of Enemy Dead	13/43
Burnett Prize	411/43
Burning of Oil Fuel	293/43
Burns - X-ray - Prevention	456/43
"Burrabra" H.M.A.S. - Paying off	†127/44
Business Member - Naval Board of Administration	21/43;105/44
Butter - Economy in Consumption of	115/44
Butts for .303" Vickers Machine Guns on Single A.A.Mounting	39/44

C

C.A.F.O.2363/42 - Reduction of Fire and Smoke Risks in H.M.A. Ships - Application in the R.A.N.	†45/43
Cameras - Use in Northern Territory and other Advanced Bases - Control of Photography	23,436/43
Camouflage and External Painting - Standardization of Colour Shades and Introduction of A1 and A2 Class Qualities Paint	400/43
Candidates for Examination for Higher Rating in the Sick Berth Branch	64/43
Canned Meats - Warranty period for	567/43;68,235/44
Cans for Meat Packs - Embossing of	174/43
Canteen and Mess Stocks - Insurance of	140/43
Funds - Accounting for Articles Purchased	649/43
Stores for H.M.A. Ships	153/43
Canteens - Naval - Chocolate and Confectionery for	596/43
- Sale of Proprietary Medicines in	329/43
- Stores - Supply of	285/44
- Supplies of Citric Acid for	281/43
Canvas Flag Wallet for A.M.S. Vessels	114/44
Hose Gaiters to Prevent Chafing	193/43
Tubing - Prolonging Life	92/44
Cap Badge(s) - Metal, for Chief Petty Officers and Officers	234/43
- Officers'	244/43
- Ribbons	299/43
"Cape Leeuwin" - H.M.A.S.	†109/43
Caps - Blue for Officers and Men Proceeding to the United Kingdom Ratings	46/44
191/43	
Captain of Heads Allowance	238/44
Carbon Paper and Typewriter Ribbons	427/43
Cards, Signal - A.B.R. 232 - Issue to Ordinary Seamen, V/S	288/43
Care and Maintenance of Bofors Guns	†163/43
- 20 M.M.	121/43
of Stores	282/43

† Denotes C.C.N.O.

Subject

C - contd.

Carriage of Shale or Colliery Refuse as Ballast in Ships carrying Explosives	158/43
Carriers - Ammunition, Double, for O.Q.F.4" Mk XIX and O.Q.F.4" Mk.XVI*	328/44
- Quadruple, Ammunition and Carriers	
Shell Quadruple - Transfer to Gunmounting Department	182/43
Cars - Allowance for Use of Private Motor	277/43
Cartridges - Cases - Q.F.4" XVI* Gun - Withdrawal	44/44
- Repair of	150/43
- Marking of, with Sub-lot XJ	54/44
- M.L.9.5 in D.C.T. Cordite h.s.c.t.134-055, 4 oz.0 drms. Mk XII Introduction of	†75/44
124/058, 5 oz.14 drms. Mk. - Withdrawal	65/44
- Q.F. 2-Pdr. H.V. Mark VIII Gun H.E. Mark X.L. Filled Glascoed 8/41 and 9/41 - Restricted	55/43
- S.A., Ball 9 m.m. of D.I.L. Manufacture - Restriction .303" Land Service	95/44
.455" Ball, Revolver - Mark II Cartridges to be replaced by Mark VI	250/43
- Signal 1" Red of M.E. 1942 Manufacture :	
To be landed	181/43
With Sub-Lot XJ - Marking of	74/43
141/43	141/43
Case Markings - Shipment of Mining Stores	216/44
Cases - Cartridge - Repair of	150/43
of Sea Sickness - Medical Surveys on	†137/43
- Packages etc. for Port Moresby, Marking of	320/43
Cash Advances to Fighting French Warships	†75/44
H.M.A.Ships from U.S. Ships	303/44
Vouchers and Forms - Captains Signature	150/44
Categories - Drafting	90/43
Cells - LL.57/3 - For LL.Sweeps - A.M.S. Vessels	78/44
Censorship - Naval	25,98,177/44
Census - Annual - Office Machinery	22/44
Ceremonial Band Instruments - Naval Reserve Depots	409/43
Certificates - Board of Trade, R.A.N. Officers	306/43
- Disposal of, on Reversion - R.N. Ratings on Loan to the R.A.N.	190/44
- Naval Watchkeeping - Naval Reserve Officers	256,319/44
- P.M.G. - Examination for - Eligibility of Telegraphist Ratings for Exemption in Certain Subjects	75/44
- Service and Pay Accounts - H.M.A. Ships attached to Eastern Fleet	57/44
Change of Name - Channel Patrol Boat "Egeria"	256/43
- H.M.A.S. "June"	517/43
Address - Directorate of Medical Services of Netherlands East Indies	584/43
Class of Uniform - Outfit Gratuities on	548/43
Channel Patrol Boat "Egeria" - Change of Name	256/43
Chapel Equipment	680/43
Charge - Transfer of, between storekeeping officers, Naval Store Accounts	251/43
Charges for Blankets lost by neglect	59/43
Officers' (Naval Stores)	253/43
Reduced - use of, for Practice - Q.F.4" Mks.XVI - XVI* Guns	†80/43
Charter - Stores remaining on requisitioned vessels on termination of	574/43

† Denotes C.C.N.O.

Subject

C - contd.

Charts - Admiralty - Correction of - in H.M.A.Ships	101/43
Chemical Warfare Training	361/43
Chests - Labelling and Marking of	37/43
- Steel, for A.M.S. Vessels	182/44
Custody of Confidential Books in Fairmiles	†21/45
Chevrons for War Service	219/44
- Issue of - Summer Uniform - Naval Dockyard Police	190/43
Chief Petty Officer - Advancement to - R.A.N.R. Petty Officers	290/44
Shipwright - Advancement to - Qualification	322/44
China, Earthenware, and Glassware - Shortage of Supplies	532/43
Chocolate and Confectionery for Naval Canteens	596/43
and Messes	138/44
- Condemnation of	175/43
Cholera - Innoculation Against	†149/44
Christmas and New Year Greetings - Telegrams	604/43
Cinematograph Projectors	636/43
Circulating Water Systems in Fairmiles Motor Launches - Modifications to	326/43
Citric Acid for Canteens, Supplies of	281/43
Civil Gaols, Subsistence of Persons in	227/43
Claim Forms for Compensation - for Total Loss of Uniform Clothing - Ratings - Introduction of Forms A.S.103Y and A.S.103Z	242/44
Classes and Examination for Seaman Petty Officer and Leading Seaman	215,305,653/43
Cleaning Gear, Economy in the Use of	295/43
Clearing Charges - Ammunition - 20 M.M. Oerlikon	151/44
Clips Cartridge No.25 - Reeving of Beckets	164/44
- Inglefield and Unserviceable Flags - Return to Store	69/44
Cloak Room - Military - Adelaide Railway Station	515/43
Close Range Weapons and Small Arms - Precautions	467/43
Clothes Rationing	480/43
Clothing - Additional Tropical Khaki - Supply to Ratings serving in Northern Areas	624/43
and Uniform - Issues of on repayment to Personnel of Allied Navies	369/43
- Royal Australian Naval Women's Services - Authorized Kits	375/43
- Gymnastic Shoes	19/44
- Supplies	189,464/43
Articles and Uniform - Ratings - Compensation for Loss of or Damage to	204/43
- Asbestos for Fire-fighting	621/43
- Civilian - Supply of, to Members of the Naval Forces on Discharge	214/44
- Issue of Loan Protective Clothing to Gunners of Maritime Troop, Royal Artillery	389/43
- Issued on Repayment - Form A.S.1048 - Daily abstract of	156/43
- Issue of, to Survivors	529/43
- Special - for Personnel in Forward Island Areas	224,282/44
- Khaki, Tropical	402/43
- R.A.N. Auxiliary Service Ratings	461/43
Maintained for Issue on Repayment to Ships' Companies - Amendment to Official Memorandum	51/44
- Oilskin Anti-Gas - Upkeep and Repair	21/44
and Rubber Sea Boots - Storage of	550/43,245/44
- Prices of - Maintained for Issue on Repayment to Ships Companies - Official Memorandum	285/43

† Denotes C.C.N.O.

Subject

C - contd.

Clothing - contd.	
- Protective	231/44
for Fire and Repair Parties	280/45
- Loan - for Boom Depots	349/45
- Rationing - Bed Linen	185/44
- Special - for Mosquito and Sand Fly Infested Areas	168/45
Issues for Personnel in Forward Island Areas	625/45
to D.E.M.S. Ratings - Lifesaving Waist-	
coats and Torches	505/45
- Supplies and Uniform - Repayment Issues of Materials	171/44
- Supply of Civilian Clothing to Members of the Naval	
Forces on Discharge	390/45
- Tropical	171/45
Clubs - Australian Defence Canteens Service	47/44
Coal for H.M.A. Ships - Procedure Governing Supplies	32/44
Coastal Craft - Fire Precautions	70/45
Coats, Waterproof - Belts	298/45
Code and Cypher Machines - Installation in H.M.A. Ships	†112/44
Coder Ratings - Temporary Commissions	582/45
Coder's History Sheet - Form A.S.1246 V	627/45
Coders, Visual Signallers, T/P and Automatic Morse Operators,	
W.R.A.N.S. - Advancement	204/44
Coding Branch	359/45
- Pass Professional Examination	60/44
- Re-examination for Ordinary Coder	16/44
Machines and Spare Parts - Transport of	†24/44
Coil, Sisal and Manila Cordage	504/45
Cold Room - Refrigerating Plant for A.M.S. Vessels	210/44
Combination Suits - One and Two Piece - Cutting of Sleeves	370/45
Combined Operations - Advancement of Ratings Trained in	221/44
Combustion Cones for Boilers - Permanent Naval Stores	91/44
Comforts - War	525/45
Command - Naval - New Guinea Area	†67/45
Commander-in-Chief, Eastern Fleet - Address of	†90/45
Commercial Type Pyrotechnics Landed from Requisitioned Ships	588/45
Commission - Commonwealth Savings Bank Agencies	85/44
- Ships not in	†1/45
Commissioning of H.M.A. H.D.M.L. 1521	†156/45
1522	†18/44
1523	†19/44
1524	†157/44
1525	†149/45
1526	†23/44
1529	†158/44
1538	†129/44
1539	†147/44
1540	†110/44
1552	†109/44
M.L. 809	†124/45
810	†154/45
811	†148/45
812	†161/45
817	†162/45
824	†159/45
825	†29/44
826	†4/44
827	†91/44

† Denotes C.C.N.O.

Subject

C - contd.

Commissioning of - contd.	
H.M.A.S. "Alatna"	†28/44
"Arcadia"	†6/44
"Barcoo"	†17/44
"Bombo"	†27/44
"Borough Belle"	†172/45
"Cowra"	†146/45
"Forceful"	†156/45
"Gasooyne"	†158/45
"Gunbar"	†152/45
"Harman"	188/44
"Junee"	†76/44
"Kanimbla"	†171/45
"Kiama"	†22/44
"King Bay"	†155/45
"Krait"	†77/44
"Marynong"	†119/45
"Parkes"	†124/44
"Poyang"	†166/45
"Sprightly"	†59/44
"Strahan"	†59/44
"Valangen"	†153/45
"Vigilant"	†90/44
"Westralia"	†5/44
"Whangpu"	†120/44
Tug "Toorong"	†155/45
Commissions - Temporary - Selection of Ratings from Lower Deck	105/45
Committees Welfare	247/45
Commonwealth Savings Bank - Agencies	85/44
Communications - Branch - Advancement	105/45
- British - U.S. - Flag	557/45
- Depth Charge	†21/44
with the Press	153/44
Compass Equipment - Sperry, Commercial Gyro - Maintenance	†51/45
(Gyro) Mark XIV - Instructions - Mod.I Oiling Chart, Item 15	598/45
- Sperry Mk.XIV Mod.I Gyro - Incorrect Fitting of Transmitter	
Connecting Cables	514/44
Compensation for Loss of or Damage to Uniform and Clothing Articles	204/45
Tools	184/44
Total loss of Uniform and Clothing - Ratings	147/44
Components - A/S - Defective	502/45
Compulsory Making of Wills	47/45; 220/44
Concession Fares - Victorian Railways, on Suburban Lines and to	
and from certain Country Stations - N.A.P.	14/45
Messages - to and from Naval Personnel	514/45
Travel - for Members of the Forces - in N.S.W.	50/45
Warrants - Leave Travelling - Issue of	273/45
Condemnation of Chocolate	173/45
Condemned, Unserviceable etc. Stores - Salvage of - Army Salvage	
Service	267/44
Condition of Stores and Equipment returned to Victualling Yards	167/45
Confidential Admiralty Fleet Orders and Admiralty Fleet Orders	178/45
and Secret Correspondence - Security	†99/44
Books in Fairmiles - Steel Chests for Custody of	†21/45
- Instructions for the Accounting, Custody, etc.	
of	†170/45
Commonwealth Navy Orders - Issue of	196/45
Correspondence - Registration	300/44

† Denotes C.C.N.O.

Subject	C.N.O. or C.C.N.O. No.
C - contd.	
Confidential Messages - Transmission in Plain Language over Teleprinter Channels	98,133/44
Navy Orders - Issue of	†1/44
Reports on Naval Reserve Officers	360/43;257/44
Confirmation and Promotion of Naval Reserve Officers	301/44
Provisional Promotion for R.A.N.R. and R.A.N.V.R. Officers in Time of War	538/43
Qualifications for Stoker Petty Officer - Acting Leading Stokers	518/43
Conjugal State of Service Personnel - Disclosure of Information regarding	542/43
Conservation of Tyres and Tubes	279/43
Consignments of Victualling Stores Delivered in H.M.A. Ships in a Deficient or Damaged Condition - Accounting for	256/43
Consulting Oral Specialist to the R.A.N.	161/43
Consumable Naval Stores in Merchant Vessels Commissioned for Naval Service - Accounting for	366/43
- Issue of to H.M.A. Motor Patrol Boats and Small Vessels in which Accounts of Consumable Naval Stores are not required to be maintained	573/43
Store Ledger Sheets - Amendment of Form A.S.151	246/44
Consumption of Butter - Economy	115/44
Containers - Anti-Gas Respirators	†145/43
Contract(s) at Adelaide - Ratings' Made-to-Measure Uniforms	257/43
Prices, Reduction in - Alteration to Jackets of Petty Officers and Men not Dressed, as Seamen	264/43
Rates - Fresh Provisions - At Melbourne	194/43;101/44
- At Sydney	194,356/43
Supply of Ratings' Made-to-Measure Uniforms by private outfitters at Hobart	115/43
Perth	116/43
Sydney and Melbourne	39,114/43
Continuation of Allotments of Members of the R.A.N. who are Re- ported Killed, Missing - Presumed Killed, Missing or Prisoners of War	199/43
Control of Photography - Cameras - Use in Northern Territory and other Advanced Bases	436/43
Veneral Disease - Melbourne Area	†40/44
- Prophylactic Centres	†132/44
Controlled and Observation Mining Ratings - Badges	96/43;7/44
Convalescent Home for Women's Services	284/44
Leave Prior to Discharge - "Invalided" from R.A.N.	440/43
Convoy Escort Organization	†121/43;†31/44
Protection - Liaison between Naval and Air Force Officers engaged on	599/43
Signal Ratings	48/43
Cooks - Officers' and Ships' - Special Issue of Boots to	460/43
- W.R.A.N.S. - Galley Shoes for	77/44
Cordage - Coir, Sisal and Manilla	504/43
Cordite Landing	26/43; 30,180/44
- Quarterly Return of Temperatures of - Form S.1147A - Non-Rendering	101/43;100/44
Records - Maintenance on Board H.M.A. Ships	89/44
Correction of Admiralty Charts in H.M.A. Ships	101/43
Correspondence and Mails for N.O.I.C. Hobart	362/43
Courses - at Sydney and Melbourne Technical Colleges	146/43

† Denotes C.C.N.O.

Subject	C.N.O. or C.C.N.O. No.
C - contd.	
Correspondence Courses - contd.	
- Vocational Training during War	340/43
on Naval Armament Store Matters - Naval Officer- in-Charge, Brisbane	174/44
Orderlies and Postmen	239/44
- Secret and Confidential - Instructions reacknowledg- ment, Custody, Disposal, etc.	†56/44
Corrigendum to Navy Order 26 of 1943	†96/43
69 of 1943	119/43
84 of 1943	†107/43
103 of 1943	157/43
144 of 1943	209/43
168 of 1943	262/43
215 of 1943	334/43
248 of 1943	303/43
360 of 1943	410/43
404 of 1943	567/43
411 of 1943	465/43
458 of 1943	515/43
528 of 1943	226/44
24 of 1944	96/44
54 of 1944	131/44
66 of 1944	103/44
71 of 1944	116/44
169 of 1944	216/44
Corvettes, "River" Class - Reclassified as Frigates	†42/43
Cots - Stretcher - Pattern 474 - Supply	243/44
Counter - Measures to Acoustic Homing Torpedo - F.X.R. Gear	†120/44
Coupons - Food - Naval Personnel	266/44
Courses - Navigation	59/44
Cremation of Deceased Service Personnel	323/44
Crystal Control - W/T Transmitters Fitted for - A.W.A. Type	104/43
Cuff Lacing Worn by Lieutenant-Commanders R.A.N.R. and R.A.N.V.R. - Uniform	127/43
"Current Affairs Bulletin" and Journal "Salt"	155/43
Custody of Keys of Safes and Chests in Small Ships	†52/44
Naval Stores	131/43
C.W.I. Forms - Forwarding of	79/43
Cylinder Liquid - Test of Recoil - Gun Mountings	192/44
Cylinders - Gas - Contractors - Return of	99/44
- Empty - Return of	48/44
For Engineering and Medical Purposes - Marking	254/43
Industrial Gases	262/44
Medical Purposes	328/43
- Water Pressure Test	289/43;295/44
Cypher and Signal Logs - Disposal of	†44/44

D

Daily Abstract of Clothing Issued on Repayment - Form AS.1048	156/43
Damage to or Loss of Uniform and Clothing Articles - Compensation for - Rations	204/43
Railway Property and Accidents Sustained by Members of the Services - Personnel travelling by Train	200/43

† Denotes C.C.N.O.

Subject

C.N.O. or
C.C.N.O. No.

D - contd.

Dark Adaptation - Night Vision - Supply of Dark Adapting Goggles	†164/43
Darwin - Naval Armament Depot	146/44
Base - Organization	197,†112/43
Hospital	52/43
Dating of Passing Professional Examination for Higher Rating ..	179/43
D.C. Pistols - Expenditure Six Monthly Ending 30th June, 1943 -	
Analysis	†79/43
- Fitted Diaphragms, I.R. St. No.6067 - Test of "Safe"	
Positions	419/43
- (M) Type B-B* - Introduction of Klingerite Washers	441/43
Deaths - Information to be forwarded where Personnel die from	
disease or injury	229/44
Deceased Personnel - Letters Found Amongst Effects of	56/44
Service Personnel - Cremation of	523/44
Deck Log and Ship's Log - Instructions for compiling	337/43
Decorations, Awards and Honours	12,85,211/43
"De Facto" Wife - Change of Term	490/43
Defective A/S Components	502/43
Defences - Seaward - Addresses	†22,†60,†110, †150/43;†136/44
"Deferred" and "Basegram" Prefixes - Need for greater use of ..	2/43
Pay	†167/43
of Mobilized Personnel	27/44
on "transfer to Another Arm of the Services	225/43
Defensively Equipped Merchant Ships - Paravane Towing Ropes ..	6/43
Dehydrated Vegetables	175/43
Delegation of Authority - Supply of Spectacles	297/44
Powers -	
National Security (General) Regulations -	
Control of Lighthouses, Buoys, Beacons, etc. (Reg.46) ..	536/43
Traffic at Ports (Reg. 64)	536/43
General Control of Navigation (Reg.45)	536/43
Handling and Conveyance of Ammunition in Ports (Reg.66) ..	536/43
Immobilization of Vessels (Reg.45D)	536/43
Measures for Safety of Australian Ships (Reg.47)	536/43
Navigation Order (Reg.45)	536/43
Power to arrest and hold in Custody certain Seamen	536/43
Prohibited Places (Reg.4)	536/43
Restrictions on Departure of Ships (Reg.45B)	536/43
Stoppage of Ships (Reg.24)	536/43
Demands for Naval Stores	635/43
Replenishment of Naval Stores	99/43
Victualling Stores - Economy in Use of Forms	255/43
D.E.M.S - Binoculars for	232/44
- Gunnery Equipment - Painting of	330/44
Ratings - Badges	93/44
- Issue of Loan Protective Clothing to Gunners of	
Maritime Troop, Royal Artillery	368,389/43
Whistles and Lanyards	657/43
- Oerlikon Ammunition Outfits for	†56/43
- Personnel - Liability for Pay, etc.	159/43
- Ratings, Drafting Records, etc.	320/44
D.E.M. Ships and Small Ships - Handling Explosives in	397/43
- Ratings recommended for Service in	65/43
Dentures and Spectacles - Loss through Active Service	347/43
Dependant Allowance - Payment of - "Dependent Female" (Formerly	
termed "De Facto" Wife)	668/43

† Denotes C.C.N.O.

Subject

C.N.O. or
C.C.N.O. No.

D - oontd.

Dependants of Members of the Forces who have married abroad -	
Passages to Australia for	600/43
Depth Charge(s) and Associated Stores - Weekly Stock Reports ..	†72,†135/44
at Australian Ports and in Armament Store Issuing	
Ships - Reserves of	†37,†66/43
Chutes - Modification to Method of Securing to	
Deck - Motor Launches	†16/44
- Repositioning - M.Ls.	152/44
Communications	†21/44
- Dummy - For Exercise Purposes	†11/43
Equipment - Modification of Depth Charge Rails and	
Templates	†125,620/43
Expenditure, Six Months Ending 31st December,	
1942 - Analysis	†8/43
1943 - Analysis	†42/44
Mark VII - VII* Filled Minol	†106/44
- Minimum Speeds of Ships and Depth Settings for	
Dropping	†9/43
Pattern Control - Introduction - Alterations and	
Additions	121/44
Pistols - Diaphragms I.R. St. No.6067 - Precautions	267/43
- "Half Cook" Position	†143/43
- History Sheets	34/43
and Keys, Depth Adjuster -	
Disposal	149/43
- Details required	145/44
- Form O426	94/44
- Mark VII - IX - Locking Screws	124/43
VIII* - Distribution	†12/43
- VIII*	†10/43
- Distinguishing Markings	55/43
- Modification for Marks XIII A and XIII* -	
Apparatus Testing Adjuster	345/43
- Routine Tests	421/43
- Plugs Wood, Primer - Tube Stamp No.6053	165/44
- Practice Expenditure	122/44
- Precautions in Hot Climates	75/43
- Preservation of Markings	605/43
Thrower Pistols - Spares	65/44
(A.F.O.1934/43)	501/43
Throwers - Firing Trials - Ships Fitted with Four	
Throwers	†126/43
- H.M.A. Ships - Position, Angling and	
Clearances from Ship's side	†116/43
- Mark II - Replacement	†25/44
Traps - Modification to Check Pawls	560/43
Type (M) and Depth Charges Mark VIII - Defective	
Bungs Charge Case	196/44
With Split Charge Cases - Reports required	162/43
Deserters and Absentees - Warrants of Arrest for	451/43
Recovered - Advancement of	26/44
Despatch of Naval Armament, Gunmounting and Torpedo Stores to	
Melbourne	420/43;43/44
Personnel to Sydney for Medical Observation or	
treatment not requiring Hospitalization	258/44
Destroyers - R.A.N. Accounts	257/44
Detention or Imprisonment - Disposal of Ratings after Sentence	
- Personnel sentenced to	250/43
- Quarters - Sydney	5/43
† Denotes C.C.N.O.	487/43

D - contd.

Deterioration of Cast Iron Condenser Doors - A.M.S. Vessels ..	11/44
Detonators - No.25, Mark I Lot 55, Filled M.E. 8/41	292/45
- Withdrawal of	98/45;100/44
- Percussion, Watertight, Mark VI and VII	16/45
VII Lot 141 B.R.8/41 - Withdrawal	41/44
D/F Equipment A.W.A. Type C. 143A - Fitting of - Alteration and Addition - A.M.S. Vessels	†85/43
D.G. Permanent - Installation of, on A.M.S. Vessels	†82/45
Diagonal Serge	532,565/45
Diaphragms I.R. - to be Fitted to Depth Charge Pistols	29/44
Dies, Stocks and Taps - Adoption of Commercial Type for Use in H.M.A. Ships and Establishments	367/45
Difference in Pay to Ratings Performing Higher Duties - Naval Financial Regs. and Instrns., Art.74	365/45
of Pay - Electrical Artificers, Ordnance Artificers and Shipwrights	248/45
Directing Gear - A/S Sets Type 128	†84/45
Direction(a) for Principal Naval Overseers, Overseers and Inspecting Officers	569/45
Under the Wireless Stations Control Order	210/45
Directorate of Medical Services of Netherlands East Indies Forces - Change of Address	584/45
Discharge - Applications from Naval Personnel for	205/44
from R.A.N. on Account of Physical Unfitness for Service	93/45
- Retention of Kit on	549/45
Discharged Naval Personnel - Rehabilitation Procedure for	14/44
Discharges to Hospitals Abroad	585/45
Disclosing of Information regarding Congugal State of Service Personnel - Service Matters	542/45
Discontinuance of Supply of Certain Items - Mess Gear	307/45
Discrepancies in Stores Shipped	10,66/45
- Reports A.D.690 and O.9	51/44
Disposal of Cypher and Signal Loss	684/45
Mines Rendered Safe	†44/44
by R.M.S. Parties	251/44
Obsolete and Unserviceable Films - Instructional Films	164/45
Ratings after Sentence of Detention or Imprisonment	296/44
Unserviceable American Ammunition	250/45
Divers - Selection of Ratings for	†78/44
Diving Equipment	149/44
Dockyard Police Naval. - Summer Uniform - Issue of Chevrons	†115/45;†105/44
Domes A/S - Losses of, and Damage to	190/45
Draft - Medical Examination Prior to	†18/45
Orders and Instructions	120/44
Drafting, Categories	541/45
and Personnel found Medically Unfit	90/45
of Personnel - Malaria Control	24/45
- W.R.A.N.S.	118/44
Dragnets - Allowance	159/44
Drawing and Painting Schools, Victoria	311/45
Dress, Battle	138/45
Officers'	151,265/45
Drill - Amendments to - B.R. 274/41 - Handbook and Drill for 20 m.m. Oerlikon Machine Gun	†50/44
Tunics with Blue Facings	371/45
Drogues and Kites for Anti-Aircraft Targets - Discontinuance of Supply	71/44
Drydocking H.M.A. Ships - Precautions to be observed to Prevent Damage to Asdic Gear, etc.	146/44
	525/45

† Denotes C.C.N.O.

Subject

D - contd.

Duffel Coats, Blankets and Towels for Survivors	300/45
Dummy Depth Charge for Exercise Purposes	†11/45
Duplicate Keys etc	†41/45
Duplicators - Spirit - Use of Methylated Spirit	407/45
Duty Free Articles for H.M.A. Seagoing Ships	28/45
E	
Earthenware, China and Glassware - Shortage of Supplies	552/45
Plates	81/45
Eastern Fleet - Address of the Commander-in-Chief	†90/45
- H.M.A. Ships attached to - Service Certificates and Pay Accounts	57/44
Echo Sounding Equipment - Periodical Material Reports	†16/45
Economy in Bristles - Care of Paint Brushes	348/45
Consumption of Butter	115/44
Expenditure	598/45
the use of Bristle - Discontinuance of Purchase of Pattern C.280 and C.281 Lash Tool Brushes during Hostilities	65E/45
Cleaning Gear	295/45
Coal, Coke, Gas and Electricity	608/45
Cordage and Coir Fenders - "Apple-ring" Type Fenders - Manufacture of	634/45
Educational Test 1 - Results - December 1942	71/45
- March 1943	272/45
- June 1943	468/45
- September 1943	81/44
- December 1943	203/44
- March 1944	318/44
- Higher - R.A.N. - October 1942	104/45
- April 1943	338/45
- October, 1943	156,248/44
Efficiency - Assessment of	120/45
of A.M.S. Vessels	†48/45
"Egeria", Channel Patrol Boat - Change of Name	236/45
Electric Fans - H.D.M.Ls	279/44
Electrical and Ordnance Mechanic Branches	82/44
Electrodes, Securing of Floats to - "LL" Sweepers	†20/45
Eligibility of Telegraphist Ratings for Exemption in Certain Subjects of the Examinations for P.M.G. Certificates	75/44
Embossing of Cans for Meat Packs	174/45
Emergency Rations for Aircraft Operating from H.M.A. Ships	67/44
Water Ration for Personnel at Sea - Supply of Water Bottles	156/44
Employment and hours of Work for Skilled Tradesmen	65/45
Empty Gas Cylinders - Return of	48/44
Enemy Submarines - Attacks by Surface Craft on	†3/45
Engine Operating Hours between Overhauls - Fairmile Motor Launches	344/45
Register - M.Ls.	386/45;162/44
Room Bilges - Fitting in - A.M.S. Vessels	†69/44
Ratings - Examination of	198/45
- Results April, 1942	92/45
1943	652/45

† Denotes C.C.N.O.

Subject

E - contd.

Engine Room Ratings - Examination of - Results - contd.	
- Training of	13/44
September, 1943	4/43
Entry into the Naval Forces - Examination and Record Form -	
Form A.M.6	455/43
to Enclosed Wharves - Authority under National Security	
(General) Regulation 7A	493/43
Equipment and Fittings - New Constructions	431/43
- A/S in M/Ls. - R/T Interference	†61/44
- Asdic, Half-Yearly Reports on	†19/43
- D.G. and S.A. Voltage Regulation in Auxiliary Minesweeping	
Vessels fitted with	†14/43
- Diving	†115/43;105/44
- D/F - Alteration and Addition - Fitting of D/F Equip-	
ment A.W.A. Type C143A - A.M.S. Vessels	†85/43
- Echo Sounding - Periodical Material Reports	†16/43
- Fire Fighting - Advanced Base Ports	512/43
- Trials - Reports	161/44
- I.F.F. - Return of Type A.B.K. Sets to Store on Re-place-	
ment by Radar Type 253	†96/44
- Life Saving - Red Distress Signals and Benzadrine Tablets	
- Sleeves and Torches for Inflatable Lifebelts	†154/43
of Small Ships - Maintenance of	126,212/44
- Radar - Allocation of	42/43
- Test - A.M.S. Vessels	†142/44
- R.M.S. and B.S. - Afloat	†14,†71/44
- Sperry and Commercial Gyro Compass - Maintenance	†13/43
- Testing A/S - Fairmiles and H.D.M.Ls	†31/43
- U.S.N. Type Radar - Spares for	†74/43
- Web - Pattern 1937	†33/44
- W/T Testing - for Frigates	137/44
- W/T Testing - for Frigates	194/44
Escapes from Enemy Territory	51/43
Escort Organization - Convoy	†121/43;†31/44
Refresher Training Organization	†55/44
Vessels Fitted with Radar - Modification to Bridge Chart	
Table	†134/44
Establishment Lists - W/T, A/S, Radar etc. Equipment	311/44
Establishments - H.M.A. Shore - Name Ships	270/44
- Payment of Allowance for Charge	
of Naval Armament Stores	235/43
- of Small Arms for Shore Bases	†20/44
- R.A.N. - Naval Stores	135/44
Euston Reef Beacon - Radar Reflector	†119/44
Evaporator Systems - Modifications to H.M.A. Frigates	†150/44
Examination and Classes for Seaman Petty Officer and Leading	
Seaman	215,305/43
for the Rank of Paymaster Lieutenant-Commander, R.A.N.	
of Engine Room Ratings	212/43;202/44
- August, 1942 - Results	198/43
- April, 1943	92/43
- September, 1943	437,652/43
- Sick Berth Staff - November, 1942 - Results	13,191/44
- May, 1943 - Results	91/43
- November, 1943 - Results	483/43
- Professional for Higher Rating - Date of Passing	
Warrant Engineers and Warrant	
Mechanicians	104/44
Mechanicians	179/43
Mechanicians	286/43

† Denotes C.C.N.O.

Subject

E - contd.

Examination - Professional for Writers and Warrant Supply Officers	304/43
- Sick Berth Staff - Results - November, 1943	104/44
Excessive Temperatures of R.U. Ammunition	186/43
Executive Officers - Radar Courses for	†115/44
Exercise of Powers of Arrest under National Security Act 1939-1943	23/43
Exhaust Pipes - Modification of - Fairmile M.Ls.	†152/43
Exhaustion of Supply of Rubber	296/43
Expenditure - Abnormal - Accumulators	181/44
- D.C. - Six Months Ending 31st December, 1942 -	
Analysis - 1942	†8,79/43
1943	†42/44
on Behalf of Netherlands - Classification	187/44
Explosive Charges in Patrol Craft	†99/43
Explosives ex H.M.A. Ships - Annual Inspection	111/44
in Small Ships and D.E.M. Ships - Handling	†397/43
- Periodical Examination of	277/44
- in Shore Establishments other	
than Naval Armament Depots	488/43
External and Camouflage Painting - Standardization of Colour Shades	
and Introduction of A1 and A2 Class Qualities Paint	400/43
Extra Issues of Provisions - Fruit and Tomato Juices	672/43
Extractors - O.Q.F. 4-in. Mark XVI* Guns	†11/44
Eye Shields - Anti-Gas - and Ointment - Revision of Allowances	209/44
Eyeshooting Sights - Short Range A.A. Weapons	148/43

F

Failure of Armament Material and Ammunition - Rendering of Forms	
S.1148 (h) (i) and (j)	294/44
Gun Armament Material and Ammunition	144/44
on 2-in. U.P. Pillar Box Mountings	377/43
Failures - P.A.C. Rockets	3/44
Fairfax, Naval Officer-in-Charge	†33/43
Fairmile Identification Lettering	552/43
Motor Launches - Engine Operating Hours between Overhauls	
- Modification of Exhaust Pipes	344/43
to Circulating Water Systems	†152/43
- Permissible Revolutions	326/43
Personnel - Periodical Medical Examination of	343/43
Rudders	540/43
Type "B" Motor Launches - Slipping of	293/44
Type "B" Motor Launches - Slipping of	12/44
Fairmiles H.D.M.Ls. and A/S Rescue Boats - Supply of Medical Stores	
- Testing Equipment	44/43
- Testing Equipment	†74/43
Fan Engine - Steam Driven Boiler Room - Vibration of - A.M.S. Vessels	
Ventilating - Loss of	†123/44
Fans - Electric - H.D.M.Ls.	66/44
- Steam Driven Boiler Room - Modification to A.M.S. Vessels	
Fans - Electric - H.D.M.Ls.	279/44
Fans - Electric - H.D.M.Ls.	195/44
Fares of Relatives attending Funerals of Deceased Service Personnel -	
Payment of	274/44
Fenders - Wattle Rod	280/44
Fighting French Warships - Cash Advances for	†75/44
Filling Recoil Cylinders - 4-in. Gunmountings Marks XXIII and XXIII*	
Films - Instructional - Disposal of Obsolete and unserviceable Films	
- Radar Instructional	143/44
- Radar Instructional	296/44
- Radar Instructional	†153/43

† Denotes C.C.N.O.

Subject

F - contd.

Fire and Repair Parties, Protective Clothing for	280/43
Smoke Risks in H.M.A. Ships, Reduction of - C.A.F.O.2363/42 - Application in the R.A.N.	†45/43
Control Higher - Payment of Allowance	180/43
Extinguishers - Radar Offices	416/43
- for Motor Launches	124/44
Fighting - Asbestos Clothing for	621/43
Equipment - Advanced Base Ports	512/43
- Trials - Reports	161/44
in H.M.A.Ships - Alterations and Additions - A.F.O.5593/43	†97/44
Precautions - Coastal Craft	70/43
- Prevention of - in Motor Boats	238/43
Firearms, Private	229/43
Firings, Full Calibre	4/43
First Aid Medical Kits	70/44
Fitting of Additional Armament in H.M.A. Ships	†46/44
Foam Equipment for Fire Fighting	378/43
Spare Parts Supplied for O.Q.F.4" Mark XVI* 20 m.m. Oerlikon Barrels	†93/43 572/43
Five lb. T.N.T. Charges for Harbour Defence	†43/43
Flag of Vessels of Water Transport Units of the Australian Military Forces	640/43
Wallet - Canvas - For A.M.S. Vessels	114/44
Flags - British U.S. Communications	557/43
on Commonwealth Buildings	6/44
- Unserviceable and Inglefield Clips - Return to Store	69/44
Flashless Propellant	†144/44
Fleet Attendant Oilers - Use by Torres Strait Pilots	†70/43
- Eastern - Address of Commander-in-Chief	†90/43
Flexible Shafting for Boiler Tube Cleaning Apparatus	15/45
Floats, Securing of, to Electrodes - "LL" Sweepers	†20/43
Flour	132/43
Food Coupons - Naval Personnel	266/44
- Hygienic Handling and Proper Cooking of	80, 133/43
Rationing and Food Economy - General Instructions	265/44
- Wastage of	†16/44
Foodstuffs and Cooking Arrangements - Inspection of	154/43
Football Boots	550/43
Form A.D.495 (Report of Docking) and Form A.D.488 (Propellers and Underwater Fittings) - Procedure	354/43
A.M.6 Medical Examination and Record Form for Entry into the Naval Forces	455/43
A.M.177G Medical Store Account for Scale 'C' Medical Store	222/44
A.O.52 - Weekly Ammunition Stock Reports	589/43
A.S.23 - Safeguarding of Personal Money	106/43
A.S.98 - Revision of	126/43
A.S.98a - Revision of	126/43
A.S.103y and A.S.103z - Introduction of	242/44
A.S.151 - Consumable Naval Store Ledger Sheets - Amendment of	246/44
A.S.155x - Record of Naval Store Ledgerkeepers - Introduction of	298/44
A.S.214 - Use during Hostilities	195/43
A.S.288a - "Annual Diving Return" - Rendition of	110/45
A.S.539z - "Long Leave Book"	7/44
A.S.542 - Route Order and Travelling Expense Claim	135, 433/43
A.S.1048 - Daily Abstract of Clothing Issued on repayment	156/43
A.S.1246v - Coder's History Sheet	627/43

† Denotes C.C.N.O.

Subject

F - contd.

Form - contd.	
D.E.M.S.16 - Local Rendering for Paravane Losses due to failure of Towing Ropes	32/43
N.A.5 - Consecutive Number of Paid Voucher to be Inserted by Paying Office	255/44
O.426 - History Sheets for D.C. Pistols	94/44
S.1147a - Cordite Temperature Return - R.A.F.A's., Auxiliary A/S and M/S Vessels	†101/43
- Quarterly Return of Temperatures of Storage of Cordite - Non-Rendering	†100/44
S.1516 - Reports on - R.M.S.	163/43
T.406 - Overtime and Extra Payment	372/43
Forms and Cash Vouchers - Captain's Signature	130/44
Books	19, 29, 38, 61, 82, 100, 176, 208, 260, 302, 318, 350, 373, 408, 434, 478, 510, 566, 650/43; 49, 79, 185, 186, 198, 225, 247, 268, 315/44
- Economy in Use of - Demands for Victualling Stores	255/43
Forwarding of C.W.I. Forms	79/44
Free Kits - Issue of, to Ratings on Entry	154/44
Fremantle - Torpedo Depot	†65/44
Fresh Provisions - Contract Rates - at Melbourne	101/44
- Supply of - at Melbourne	194/43
- at Sydney	194/43
Frigates and A.M.S. Vessels - Modification to Evaporator System	†68/44
- H.M.A. - Modification to Evaporator Systems	†150/44
- Naval Store Accounting Procedure	244/44
- "River" Class Corvettes - Reclassified as	†42/43
With Reciprocating Main Engines - Maximum Continuous Power	†53/44
Fruit - Accounting for Purchases and Issues of - in Provision Accounts of Ships and Establishments	301/43
and Tomato Juices - Extra Issues of Provisions	672/43
Fuel Oil(s) - Burning of	293/43
- Measuring Tapes	270/43
- Naval Stocks in Australia	†15/44
- Nomenclature of	474/43
Full Calibre Firings	†4/43
Funds - Ships'	219/43
Funerals of Deceased Service Personnel - Payment of Fares of Relatives Attending	274/44
- Payment of Contractors' Claims in connection with	553/43; 230/44
Furniture - Wooden - Replacement by Steel, in Cruisers, Destroyers, A.M.S. Vessels and "Warrego", "Swan" and "Moresby"	503/43
Fuze No.127 Mark I, I* and II, Keys, Modified Setting Stud	291/43
Fuzes - No.401, Mark II Lot 146 V.A.O. Filled 10/41 - Withdrawal from Service for 100 per cent Examination	53/44
- No.720 - For use with U2" H.E.Shell	655/43
- Percussion D.A. No.230 - Marks to be used for guns in Twin Mountings	†65/43
- Returned from Ships - Time Mechanical - Amendment of C.B. 3063 (N.M.E.R.)	†144/43
- Time No.401 Marks I and IA	153/44
- On Board H.M.A.Ships - Annual Percentage in Wartime	253/44
F.X.R. Gear - Counter Measures to Acoustic Homing Torpedo	†120/44

† Denotes C.C.N.O.

Subject

G

Gaiters - Canvas Hose to Prevent Chafing	193/43
Galley Shoes for Cooks - W.R.A.N.S.	77/44
Gaols - Civil - Subsistence of Persons in	227/43
Garbage and Ashes from H.M.A. Ships at Outer Harbour and Port Adelaide - Disposal of	313/43
Gas Cylinders	430/43
- Boxes for	619/43
for Engineering and Medical Purposes - Marking Medical Purposes	254/43
.. .. .	328/43
- Loss of - Reports	67/43
- Return of Empty	48/44
Contractors'	99/44
- Water Pressure Test	99/43;295/44
- Use of by Enemy - Responsibility for Identification and Procedure for Reporting	†24/43
Cases - Industrial Cylinders for	262/44
Gate Vessels - and Boom Working Vessels - Additional Armament	†57/43
Gear - Cleaning, Economy in the Use of	295/43
General Instructions - Food Rationing and Food Economy	265/44
Message of "H" and "I" Series Remaining in Force	140/44
Generating Sets - Kelly and Lewis Steam Driven - A.M.S. Vessels - Governors	310/43
Generators - Stiffening of Seatings of Kelly and Lewis Steam-driven - A.M.S. Vessels - Alterations and Additions	†104/44
Gift Parcels sent to the United Kingdom from H.M. Forces Overseas - Duty Free Concessions - Army Form W.5192	444/43
Girl Guides' Holiday Gift to the R.A.N. Patriotic Fund of Victoria	535/43
"Gippeland" - H.M.A.S. - Paying off	†126/44
Glassware, Earthenware and China - Shortage of Supplies	532/43
Goggles - Protective - For Sun Sector Lookouts - Introduction	459/43
Gold Lace and other Articles made of Gold Bullion - Renovation of	8/43
Good Conduct Badges	486/43
Service Badges - R.A.N.R. - Deprivation and Restoration	61/44
Government Stores - Misappropriation - Reports to Civil Police	72/44
Governors - Kelly and Lewis Steam-Driven Generating Sets - A.M.S. Vessels	310/43
Grant for Tropical Kit	77/43
of Full and Modified "Qualified Officer" Status in the R.A.N.	74,132/44
- Special Uniform - to Officers travelling with a minimum of Baggage	159/43
Grants-in-Aid and Percentage Charge - Orchestral Band Instruments	197/44
Gratuities - Outfit - on Change of Class of Uniform	250/44
Gratuitous Replacement of Officers' Mess Traps and Seamen's Mess Utensils	8/43
Gratuity, Outfit, Tropical - Sydney	297,476/43
- Lieutenant (Emergency or Retired) - Payable on Promotion from Commissioned Warrant Officer or Warrant Officer	211/44
Graves Registration Burials - Identification of Bodies and Burial of Enemy Dead	13/43
Greatcoats - Naval Auxiliary Patrol	381/43
Grenades, Drill No.36 M.	524/43
Gun Ammunition - Reserves of, at Australian Ports and in A.S.I. Ships	†6,†100/43
and Gun Mounting - Range Tables - O.U. Books and Books of Reference	†68/43
Armament Material and Ammunition - Failure of	144/44
in Small Ships - Maintenance of	31/43
- Reports on Failure of	500/43
† Denotes C.C.N.O.	

Subject

G - contd.

Gun - contd.	
Mounting Holding Down Bolts	184/43
Mountings - Test of Recoil Cylinder Liquid	192/44
- 12-pdr.	183/43
Trials - Procedure	38/44
- Reports - 4-inch Gunmounting Marks XXIII and XXIII*	†57/44
Gunfire A.A. from H.M.A. Ships in Harbour	†77/43
Gunmounting, Naval Armament and Torpedo Stores - Despatch of, to Melbourne	420/43
- 40 m.m. Bofors	559/43
Gunmountings 4-inch Marks XXIII and XXIII* - Filling Recoil Cylinders	143/44
Gunnery Communications - A.M.S. Vessels	†7/44
Equipment - D.E.M.S. - Painting of	330/44
Ratings - D.E.M.S. - Badges	93/44
- Higher - Qualifications at Sea	228/43
- Qualifications at Sea	296/43
Guns and Gun Mountings - Bofors - Care and Maintenance	103/44
- Issues, Receipts and Inspections - Details to be Treated as Confidential	253/43
- Inspection after Firing	†140/43
- Machine, 20 m.m. Oerlikon - Gauges Striker Protrusion and High Diameter	395/43
.30" - Gauges Plug Bore Low Limit for Provisional Condemna- tion M.G. Mark I and Rods Plug Bore .30" M.C. Mk.I	587/43
.303" Bren Mark I - Springs Return Mk.II	185/43
Shoulder Shooting Lewis Vickers on Single A.A. Mountings - Butts for	39/44
- Oerlikon	523/43
- 20 m.m. - Tool, Loading Magazine - Introduction	123/43
- Oerlikon - Ammunition for - Pools Maintained at Ports and Outfits to be supplied	5/43
- Modification of Shoulder Rest	290/43
- Spare Parts	†28/43
- 20 m.m. - Care and Maintenance	220/43
- Locking of Barrels	179/44
- O.Q.F., 4-inch XIX - Assembly of Sear to Case Striker, Mark I	396/43
XVI*	266/43
- Extractors	†11/44
- Q.F. 40 m.m. - Method of Testing Blow of Striker	306/44
- Sub-machine Thompson 0.45-in., Tool Recoil Spring - Instructions for	†44/43
- 4-in. XIX, Rearming with, on H.A.L.A. XXIII*	
Mounting - H.M.A. Ships	260/44
- 4-in. Mark XXIII and XXIII*	208/44
Gymnastic Shoes for W.R.A.N.S.	19/44
Cyro Compass Equipment, Mark XIV - Instructions - Mod.1. Oiling Chart, Item 13	398/43
- Sperry Commercial - Maintenance	†31/43

† Denotes C.C.N.O.

Subject

G - contd.

C.N.O. or
C.C.N.O. No.

Gyro Compass - contd.

Mod. I - Sperry Mk. XIV - Incorrect Fitting of Transmitter Connecting Cables	514/44
Gun Sights - Modification to 20 m.m. Oerlikon Mountings ..	†139/43
- Housing Oerlikon Guns Fitted with Mk. XIV ..	254/44

H

"H" and "I" Series - General Message of - Remaining in Force ..	140/44
Hailing Equipment - A.M.S. Vessels - Alteration and Addition Item - C.A.F.O. 3963/45	†108/44
"Half-Cock" Position - Depth Charge Pistols	†143/43
Half-Yearly Reports on Asdic Equipment	†19/43
A/S Equipment - Record of Personnel	†148/44
Hammocks - Labelling and Marking of	57/43
Handbook and Drill for 20 m.m. Oerlikon Machine Gun - B.R. 274/41 - Amendment to Drill	371/43
Harbour Defence - 5 lb. T.N.T. Charged for	†43/43
Signals to denote Air Raid Warnings	†23/43
Hawser - Towing - A.M.S. Vessels	401/43
Haze Screens - R.A.N. Pattern - Modification	134/44
H.D.M.Ls. and Fairmiles - A/S Testing Equipment	†74/43
- Extraction of Fumes from Refrigerator	679/43
- Operating Hours	643/43
Heat Treatment of Shuttle Valves of Reciprocating Pumps	107/44
Hedgehog - Nomenclature to be used when demanding Stores	†182/43
Heeling Error Instruments for D.G. Purposes	546,659/43
Helmets - Sun and Khaki Covers	192/43
Higher Duties - Applications for Payment of Difference in Pay to Rating Performing - N.F.R.I., Art. 74	365/43
Educational Test - Results - October, 1942	104/43
- April, 1943	358/43
- October, 1943	156,248/44
Fire Control - Payment of Allowance	180/43
Gunnery Ratings - Qualification at Sea	228/43
Rating, Professional Examination for - Date of Passing	179/43
History of the War - Naval Medical	73/44
Sheets and Keys, Depth Charge Pistol, Depth Adjuster - Disposal	149/43
- Depth Charge Pistol	34/43
- Details Required	145/44
- Form O. 426	94/44
H.M.A. H.D.M.L. 1161 - Paying Off	†50/44
1321 - Commissioning	†156/43
1322 - Commissioning	†18/44
1323 - Commissioning	†19/44
1324 - Commissioning	†137/44
1325 - Commissioning	†149/43
1326 - Commissioning	†23/44
1329 - Commissioning	†139/44
1338 - Commissioning	†129/44
1339 - Commissioning	†147/44
1340 - Commissioning	†110/44
1352 - Commissioning	†109/44

† Denotes C.C.N.O.

Subject

H - contd.

C.N.O. or
C.C.N.O. No.

H.M.A. H.D.M.L. 809 - Commissioning	†124/43
810 - Commissioning	†134/43
811 - Commissioning	†148/43
812 - Commissioning	†161/43
817 - Commissioning	†162/43
824 - Commissioning	†159/43
825 - Commissioning	†29/44
826 - Commissioning	†4/44
827 - Commissioning	†91/44
H.M.A. Ships - Aircraft Operating from - Emergency Rations for and Establishments - Photographic Material for Use in - Reduction of Kits in	67/44
Attached to Eastern Fleet - Service Certificates and Pay Accounts	8/44
- Coal for - Procedure Governing Supplies	241/44
- Code and Cypher Machines - Installation in	57/44
- Depth Charge Throwers - Position, Angling and Clearances from Ship's Side	52/44
- Drydocking - Precautions to be Observed to Prevent Damage to Asdic Gear etc.	†112/44
- Firefighting in - Alteration and Addition - A.F.O. 5595/43	†116/43
- Fitting of Additional Armament in	325/43
- Fuzes, Time, on Board - Annual Percentage Landing in Wartime	†97/44
In Harbour - Anti-Sabotage Measures by	†46/44
- Maintenance of Upper Deck Fitting	253/44
- Photographic Record of	†76/44
- Re-Arming with 4" XIX Guns on H.A.I.A. XXIII* Mounting	178/44
- Sun Reflecting Device for	641/43
- Shore Establishment - Name Ships	260/44
- Payment of Allowance for Charge of Naval Armament Stores	33/44
H.M.A.S. "Alatna" - Commissioning	177,629/43
"Allura" - Commissioning	255,374/43
"Arcadia" - Commissioning	†28/44
"Arista" - Paying off	†111/44
"Barcoo" - Commissioning	†6/44
"Bermagui" - Re-commissioning	†92/44
"Bombo" - Paying off into Reserve	†17/44
- Commissioning	†5/44
"Borough Belle" - Commissioning	†147/43
"Burrabra" - Paying off	†27/44
"Cape Leeuwin" - Commissioning	†172/43
"Coolebar" - Re-commissioning	†127/44
"Cowra" - Commissioning	†109/43
"Emilea" - Paying off	†58/43
"Forceful" - Paying off	†146/43
"Gascoyne" - Commissioning	†86/44
"Gippsland" - Paying off	†136/43
"Gunbar" - Paying off	†156/43
- Re-commissioning	†126/44
"Harman" - Commissioning	†52/43
"June" - Change of Name	†132/44
"Junee" - Commissioning	188/44
"Kanibla" - Commissioning	517/43
	†76/44
	†171/44

† Denotes C.C.N.O.

Subject	C.N.O. or C.C.N.O. No.
H - contd.	
H.M.A. "Kiama" - Commissioning	†22/44
"King Bay" - Commissioning	†155/43
- Paying off	†54/44
"Krait" - Commissioning	†77/44
"Kuranda"	256/44
"Kweena" - Paying off	†60/44
"Ladava" - Commissioning	†108/43
"Larrakia" - Paying off	†49/44
"Lookout" - Re-naming	666/43
"Maroubra" - Paying off	†52/43
"Marynong" - Commissioning	†118/43
"Matoma" - Paying off	†94/44
"Parkes" - Commissioning	†124/44
"Pedare" - Paying off	†114/44
"Pioneer" - Paying off	†150/44
"Poyang" - Commissioning	†166/43
"Rathane" - Paying off	†93/44
"Reserve" - Commissioning	†102/43
"Rushcutter" - Organization	102/43
"Silver Cloud" - Paying off	†72/43
"Shropshire" - Transfer to R.A.N.	†47/43
"Sprightly" - Commissioning	†39/44
"Starfish" - Paying off	†163/43
"Strahan" - Commissioning	†59/44
"Sylph" - Paying off	†95/44
"Tasma" - Paying off	†43/44
"Tongkol" - Paying off	†131/44
"Topsy A" - Paying off	†101/44
"Valangen" - Commissioning	†135/43
- Paying off	†85/44
"Vigilant" - Commissioning	†90/44
- Re-naming	285/44
"Viking" - Re-naming	286/44
"Wallaroo" - Paying off	†40/43
"Westralia" - Commissioning	†3/44
"Whang Pu"	†84/44
- Commissioning	†120/43
"Wongalere" - Paying off	†125/44
Submarine "K9" - Commissioning	†59/43
- Paying off	†67/44
Tug "Toorong" - Commissioning	†135/43
Victualling Yard, Port Melbourne	552/43
H.M. Ships transferred to R.A.N. for Manning - Arrangements in respect of the Agreement between the U.K. and Australian Governments	†51,227/44
Hobart - Naval Officer-in-Charge - Mails and Correspondence for	362/43
Holding Down Gun Mounting Bolts	184/43
Homing Torpedo - Acoustic - Counter Measures to - F.S.R. Gear	120/44
Honorary Membership for Officers - Royal South Yarra Lawn Tennis Club, Melbourne	112/43
Honours, Awards and Decorations - R.A.N. Personnel	10,05,011,535,494/43
	200,288/44
Hose Couplings - India Rubber Washers for - use of correct patterns	144/43
Tubing - Canvas - Prolonging Life	92/44
Hospital Claims - Newcastle	55/43
- Naval, Darwin	52/43

† Denotes C.C.N.O.

Subject	C.N.O. or C.C.N.O. No.
H - contd.	
Hospitals - Private - Approved - Rates of treatment in	217/43
- for Naval Officers	305/44
Housing Oerlikon Guns fitted with Mk.XIV Gyro Sights	254/44
Hygiene and Sanitation - General - including the Prevention of	
Malaria - Preservation of Health	269/44
Hygienic Handling and proper cooking of Food	80,135/43
Hypodermic Outfit - Individual Morphine Sulphate Gr. $\frac{1}{2}$ or Omnopon Gr. $\frac{2}{5}$ (Tubunic Ampoule or Syrette)	379/43
I	
Ian Macdonald Memorial Prize	580/43
Identification Lettering - Fairmile	352/43
of bodies and burial of enemy dead, graves registration - burials	15/43
I.F.F. Equipment - Return of Type A.B.K. Sets to Store on Replacement by Radar Type 253	†96/44
Igniters, Torpedo, Mark XI - Lat No.144, Filled S.W.Y.N. 9/41 - withdrawal	64/44
No.217 Filled B.R.12/41 - withdrawal	155/44
Withdrawal (A.F.O.4082/43)	590/43
Illuminating Rockets 5 $\frac{1}{2}$ lb. - Prematures	40/44
Illumination of Sight Dials - 4" Mark XXIII* Mountings	327/44
Important Keys	268/43
Imprisonment or Detention - Disposal of Ratings after sentence of	250/43
Income Tax Returns	577/43
India Rubber Washers for Hose Couplings - Use of correct patterns	144/43
Industrial Gases - Cylinders for	681/43;262/44
Infantry, Landing Ships - Administration	†117/44
Inflatable Lifebelts - Torches and Sleeves for - Life Saving Equipment	126,212/44
Information - Disclosure of - Service Matters	307/43
Inglefield Clips and Unserviceable Flags - Return to Store	69/44
Innoculation against Cholera	149/44
Inspecting Accountant Officer	428/43
Officers, Principal Naval Overseers and Overseers - Directions for	569/43
Inspection - Annual - Explosives ex H.M.A. Ships	111/44
of Foodstuffs and Cooking arrangements	154/43
Guns after firing	†140/43
Service Certificates	556/43
Installations - Asdic - Types 144/5 - Training of Personnel	†70/44
Installation of Permanent D.C. - A.M.S. Vessels	†38/43
Instructions for Accounting, Custody, etc. of Secret and Confidential Books	†170/43
Compiling the Deck Log and Ship's Log	357/43
Naval Armament Store Accounting at certain Shore Establishments	20/43
- Rehabilitation Officers	601/43
Insurance of Canteen and Mess Stocks	140/43
Intercommunication - Mixed Squadron - Installation of V.H.F. R/T Set - Alteration and Addition	†95/43

† Denotes C.C.N.O.

Subject	C.N.O. or C.C.N.O. No.
I - contd.	
Interference - R/T - A/S Equipment in M.Ls.	†61/44
With W/T and R/T Reception - Radar Type A286 P/Q	†48/44
Interior - Department of - Naval Stores Expended on Naval Works - Discontinuance of Recovery of Cost of Material for Minor Repairs and Jobbing	404/43
Interstate Rail Travel - Wives and families of Naval personnel	524/43
Introduction of Cartridges M.L. 9.5-in. D.C.T. Cordite H.S.C.T.134 - D35, 4-oz. O-D.R.M.S. Mk.XII	†73/44
Rating - Ordnance Artificer (O) - For duties in connection with repair and maintenance of Optical Instruments	72/43
"Invalided" from R.A.N. - Convalescent Leave Prior to Discharge Personnel - Procedure in regard to - Rehabilitation Officers	440/43
Invalids - Use of Army Medical facilities in transfer of ..	356/43
Irregular wearing of Class III Uniform - Acting Petty Officers	259/44
Issue A.C.B.247 (R)	106/44
of Clothing to Survivors	83/44
Confidential Navy Orders	529/43
Consumable Naval Stores to H.M.A. Motor Patrol Boats and Small Vessels in which Accounts of Consumable Naval Stores are not required to be maintained	196/43;†1/44
Free Kits to Ratings on entry	573/43
Leave Travelling Concession Warrants	154/44
Loan Protective Clothing to Gunners of Maritime Troop, Royal Artillery, D.E.M.S.	273/43
Long Khaki Clothing in the Royal Australian Navy	389/43
Materials - Repayment - Uniform and Clothing Supplies ..	593/43
Mess Gear and Blankets to Personnel Travelling	171/44
Navy Orders	170/44
Uniform and Clothing on Repayment to Personnel of Allied Navies	1/43
Whistles and Lanyards to D.E.M.S. Personnel	369/43
Issues, Receipts and Inspections of Guns and Gun Mountings ..	657/43
Issuing Prices of Khaki Tropical Clothing	253/43
	27/43

J

Jackets of Petty Officers and Men not dressed as seaman - Alteration to	243/43
Joist Adjuster Rings I.R.	453/43
Journal "Salt" and "Current Affairs Bulletin"	155/43
"June" H.M.A.S. - Change of Name	517/43
"June" - H.M.A.S. - Commissioning	†76/44
Junior Writer and Supply Ratings - Typewriting experience ..	176/44

K

K.9 - H.M.A. Submarine - Commissioning	†59/43
- Paying off	†67/44

† Denotes C.C.N.O.

Subject	C.N.O. or C.C.N.O. No.
K - contd.	
Kelly and Lewis Steam-Driven generating sets - Governor - A.M.S. Vessels	310/43
Generators - Stiffening of seatings - Alteration and addition - A.M.S. Vessels	†104/44
Keys, Duplicate, etc.	†141/43
- Fuze No.127 Mk.I, I* and II - Modified Setting Stud ..	291/43
- Important	268/43
of Safes and Chests in small ships	†52/44
Khaki Covers and Sun Helmets	192/43
Tropical Clothing	402/43
- Additional Supply to Ratings serving in Northern Areas	170,624/43
- Issuing Prices of	127/43
Kitbags - Labelling and marking of	57/43
- Small	238/43
Kit - Authorized - Uniform and Clothing - W.R.A.N.S.	20,55/44
Lockers - Additional - A.M.S. Vessels	†41/44
- Medical First Aid	70/44
- Modification of Ratings'	172/43
- of Ratings drafted to Darwin, Thursday Island, New Guinea or other forward Areas in the South West Pacific	263/44
- Prevention of Deterioration in Northern Areas	443/43
- Reduction of - in H.M.A. Ships and Shore Establishments	241/44
- Variations in - Small Blue Kit Bags and Suit Cases ..	234/44
Kites and Drogues - for use as Anti-Aircraft Targets - Discon- tinuance of Supply	146/44
Klaxon Horns - Motor Patrol Vessels	418/43
"Knock for Knock" - Navy Vehicles	108,319,445/43

L

Labelling and Marking of Kitbags, Hammocks, Chests and Suitcases	57/43
Lacing of Jackets, Greatcoats and Tunics - Alteration of - Officers of Special Branch	382/43
- Uniform worn by Lieutenant Commanders, R.A.N.R. and R.A.N.V.R.	259/43
Landing Cordite	241/43;90/44
Craft Signalman (Sig.L.C.) - Institution of Non- Sub- stantive Rate	539/43
Parties - Pioneers' Tools for	558/43
Ships, Infantry - Administration	117/44
Lanterns - Plywood - Radar Types 271/3, A.272 - Maintenance ..	†38/44
Launches - Fairmile Motor - Engine Operating hours between overhauls	344/43
- Modifications to Circulating Water Systems	326/43
- Permissible Revolutions	343/43
- Motor - Engine Register	162/44
Leave or Release - Applications from Naval Personnel for	527/43
- Travelling Concession Warrants - Issues of	273/43
Ledger Sheets - Consumable Naval Store - Amendment of Form A.S.151	246/44
Legacy Club, The	625/43
Lettering, Fairmile Identification	352/43
Letters - Found amongst effects of deceased personnel	36/44
Liability for Pay, etc. - D.E.M.S. personnel	159/43

† Denotes C.C.N.O.

Subject

C.N.O. or
C.C.N.O. No.

L - contd.

Liaison between Naval and Air Force Officers engaged on convoy protecting	599/43
- Pay arrangements	141/44
Librarian (Female) - Vacancy for - Department of Defence, Melbourne	628/43
Library Books - Purchase Price Limit	225/45
- Supply to small ships	207/43
Lieutenant Commander R.A.N. - Paymaster - Examination for the Rank of - Naval Reserves - Promotion of Naval Reserve Officers to Rank or Relative Rank of	202/44
Lieutenant (Emergency or Retired List) - Outfit Gratuity payable on promotion from Commissioned Warrant Officer or Warrant Officer	359/43
Lifesaving Appliances - Provision	211/44
- Reports	252,491/43
Equipment - Red Distress Signals and Benzadrine Tablets	555/45
- Sleeves and Torches for Inflatable Lifebelts	†154/43
Linen - Bed - Clothes Rationing	126,212/44
- Table and Table Napkins - Allowances of	185/44
Liquid Human Serum - Supply of	317/43
Listening Watch - Modification for - Radar Types A.296 P/Q ..	85/43
L.L. Minesweepers - Venner Time Switch	†115/44
Sweepers - Securing of Floats to Electrodes	87/43
Sweeping Equipment - A.M.S. Vessels fitted with - Protection of L.L. Sweep Switchboards	†20/43
57/3 Cells for L.L.Sweeps - A.M.S. Vessels	25/43
Loan Issue - Blankets - Prices for Losses by neglect	†8/44
of Blue Combination Suits - N.A.P.	59/43
Brown Dungaree Combination Suits to Officers ..	36/43
Rope-soled shoes on H.M.A. Motor Patrol Boats and Naval Auxiliary Patrol Boats	58/43;112/44
Protective Clothing for H.M.A. Boom Depots	88/43
Local Rendering for Paravane losses due to failure of Towing Ropes - Form D.E.M.S.16	349/43
"Lockers for Fire Fighting and Action Repair Materials" - A.M.S. Vessels - Alterations and Additions	32/43
- Kit - Additional - A.M.S. Vessels	†63/44
Locking of Barrels - 20 m.m. Oerlikon Guns	†41/44
Screws of Depth Charge Pistols, Mark VII - IX ..	179/44
Log(s) - Cypher and Signal - Disposal of	124/43
- Magazine - Auxiliary War Vessels	†44/44
- Ship's - and Deck - Instructions for compiling ..	221/43
Long Khaki Clothing in the Royal Australian Navy - Issue of ..	337/43
Loss(es) - Anti-gas Respirators	337/43
- Bags and Hammocks during Rail Transit	593/43
- Bicycles	353/43
- Dentures and Spectacles through Active Service ..	677/43
- Gas Cylinders - Reports	426/43
- Naval Stores from H.M.A. Ships due to theft during re-fit, etc., at H.M.A. Naval Yard, Sydney	347/43
- Paravanes - Merchant Ships - Action by D.E.M.S. Staff Officers	67/43
- Pistols, Revolver	76/43
- Tools - Compensation for	18/44
- Ventilating Fan	184/44
Lubricating Grease for A.M.S. Vessels	66/44
Oil for Hall Scott Engines	670/43
H.M.A. Ships "Kybra", "Wilcannia" and "Reserve"	378/43
	109/44

† Denotes C.C.N.O.

Subject

C.N.O. or
C.C.N.O. No.

M

Machine Guns, A.A. - Annual Practice Allowance of .303" Ammunition for	†7/43
- Bren, .303" Mark I - Springs, return Mark II ..	185/43
- Oerlikon 20 m.m. - Tool Loading Magazine - Introduction	123/43
- Shoulder Shooting Lewis .303"	56/43
- Vickers .303" - Loss in transit	†78/43
.30" - Gauges Plug Bore Low Limit for provisional con- demnation M.G. Mark I and Rods Plug Bore .30" M.C. Mark I	587/43
Machinery - Coding - Transport of	†24/44
- Forms for new construction vessels	638/43
- Machine tools etc. supplied for Naval Workshops - Accounting for	108/44
of A.M.S. Vessels - necessity for purity of feedwater	86/43
- Office - Annual Census	22/44
Magazine Logs - Auxiliary War Vessels	221/43
Magazines - unlocking	276/44
Magnetic Compasses - Boxes for - return when empty ..	454/43
Mail Bags - Return of	626/43
- Correspondence for the N.O.I.C., Hcbart	362/43
- Re-direction of	137/43
Maintenance and Care - Oerlikon Guns 20 m.m.	121/43
of Bofors Guns	163/44
of Adequate Stocks of Provisions	206/43
Cordite Records on Board H.M.A. Ships	89/44
Equipment of small ships	42/43
Fittings - Upper Deck - H.M.A. Ships	178/44
Gun Armament Material in small ships	31/43
Radar Types 271/3 A.272 Plywood Lanterns	†38/44
Malaria Cases - Description of Categories	631/43
- Control - Drafting of Personnel	118/44
- Including the prevention of - Preservation of health - General hygiene and sanitation	269/44
- Measures for prevention and control	603/43
- Prevention of Spread of	275,520/43
- Supply of Stores for measures for prevention and control	15/44
- With Atebrin - Suppressive treatment (Prophylaxis) for	240/44
Marking and Labelling of Kitbags, Hammocks, Chests and Suitcases of cartridges with Sub-Lot XJ	57/43
- M.L's.	141/43
Cases, Packages, etc. for Port Moresby	54/44
Packages containing Asdic Stores	320/43
Markings - Case - Shipment of Mining Stores	†98/44
"Maroubra" H.M.A.S. - Paying off	216/44
Marriages - Prevention of Bigamous	†32/43
Master-at-Arms - Swords and Belts for	274/43
Mats and Table Cloths	346/43
Measuring Tapes - Oil Fuel	5/44
Meat Packs - Embossing of Cans for	270/43
Mechanic Branches - Ordnance and Electrical	174/43
Mechanicians - Advancement in Wartime	82/44
Medal Ribbons - Wearing with Tropical Dress	448/43
Medical Attendance of W.R.A.N.S. at Melbourne by a female medical practitioner	312/44
Cabinet - A.M.S. Vessels	616/43
Charges - Rates to be paid for services afforded by civilian practitioners	442/43
	218/43

† Denotes C.C.N.O.

Subject

U.N.O. or
C.C.N.O. No.

M - contd.

Medical - contd.	
Examination and Record Form for entry into the Naval Forces - Form A.M.6	455/43
of Fairmile personnel - periodical	540/43
prior to draft	120/44
Facilities - Use of Army, in transfer of invalids	259/44
History Documents of Personnel appointed to or on draft to R.A.N. Ships serving in the Eastern Fleet of the War - Naval	†129/43 73/44
Observation or Treatment not requiring hospitalization - Despatch of personnel to Sydney for	258/44
Officers, unmobilized - provision of service uniform	203/43
Organization in Sydney	62/43
Services - Netherlands East Indies - Directorate of - Change of Address	584/43
Store Account for Scale "C" Medical stores - Form 177G	222/44
Stores - Supply of - Fairmiles, H.D.M.Is. and Air Sea Rescue Boats	44/43
Medicines, Proprietary - Sale of, in Canteens	529/43
Members of the Forces suffering from active Pulmonary Tuberculosis Royal Netherlands Navy treated in R.A.N. hospitals and sick quarters	485/43 299,471/43
W.R.A.N.S. discharged on account of pregnancy	†116/44
Memorandum, Official - Prices of clothing, etc. maintained for issue on repayment to ship's companies	285/43
- Amendment	51/44
Memorial Prizes and Testimonials	25/44
Mental Disorder - Certification of members of R.A.N. suffering from - Members of the Forces suffering from - National Security (Supplementary) Regulations	435/43 160/44
Hospitals or Receiving Houses - Admission of Naval personnel to Merchant Vessels commissioned for Naval service - Accounting for consumable Naval stores in	566/43
Mersigs, Vcl.I - B.R.637	533/43
Mess Gear and Blankets - issue of, to personnel travelling	170,264/44
- Discontinuance of supply of certain items	10,66,425/43
for W.R.A.N.S. - Amendments to scales	205/43
- Issue of - personnel travelling to or from Darwin by the Overland route	154/43
Traps and utensils - Gratuitous replacement of	8/43
- Officers' - Replacement allowances - applicable for 1942-43	166/43
Utensils for Chief Petty Officers', Petty Officers' and Men's Messes - replacement allowances - Applicable for - 1942-43	152/43
1943-44	661/43
Messages - Concession	514/43
Metal Cap Badges for Ratings - Class III	475/43
Method of Marking Packages - Naval Stores	129/43
Microphotographic X-ray Examinations	529/44
Midshipmen, R.A.N.F. and R.A.N.V.R.	667/43
Military Cloak Room - Adelaide Railway Station	513/43
Defences in Harbour - A.A. Co-operation with	†88/43
Milne Bay - Shipment of Stores to	403/43
Mine(s) and Bombs - Rendering safe - organization round the Australian Coast	187,240,276, 309,617/43

† Denotes C.C.N.O.

Subject

C.N.O. or
C.C.N.O. No.

M - contd.

Mine(s) and Bombs - contd.	
- Rendered safe by R.M.S. Parties - disposal	164/43
- Washed Ashore - Awards for Reporting	107/43
- Depot, Byford and R.A.N. Armament Depot, Fremantle	†89/43
Rendered Safe - Disposal	252/44
Rendering Safe - Employment of personnel other than Officers	251/44
Sabotage	†54/43
Washed Ashore - Rendering of Reports	45/44
Minesweeping - A.M.S. Vessels fitted for - alteration and addition - Spur for additional Signal Halliards	†118/44
Minimum Speeds of ships and depth charge settings for dropping depth charges	†9/43
Minol filled depth charges Mk.VII - VII*	†106/44
Misappropriation of Government Stores - reports to civil police	18/43; 72/44
Misalignment between engines and propeller shafting	545/43
M.L.s. - Repositioning of depth charge chutes	†152/44
809 - Commissioning of	†124/43
810 - Commissioning of	†134/43
811 - Commissioning of	†148/43
812 - Commissioning of	†161/43
817 - Commissioning of	†162/43
824 - Commissioning of	†159/43
825 - Commissioning of	†29/44
826 - Commissioning of	†4/44
827 - Commissioning of	†91/44
Modification(s) for Listening Watch - Radar type A.286 P/Q	†113/44
of depth charge rails and templates - depth charge equipment	†125/43
Procedure for Accounting for Naval Stores incorporated in W/T, A/S Radar, etc., sets	159/44
R.A.N. pattern haze screens	134/44
- Ratings' kits	172/43
to Aerial Training System A/SI and A/S3, - Radar Types A.272, A.286 P/Q	†81/44
Bridge Chart Table - Escort Vessels fitted with Radar	†134/44
Evaporator systems - H.M.A.Frigates	†150/44
and A.M.S.Vessels	†68/44
- Method of Securing depth charge chute to dock - Motor Launches	†26/44
- Steam Driven Boiler Room fans	195/44
- Type AT5/AR8 W/T - R/T set	†80/44
Modified setting stud keys, fuze No.25 Mk.I, I* and II	291/43
Monthly Report of Proceedings	†97/43
Morse Operators - Automatic - Visual Signallers, Coc-ers and T/P - W.R.A.N.S. advancement	204/44
Mosquito and Sandfly infested areas - special clothing for	168/43
Nets	142/43; 213/44
Motor Cars - Allowance for use of private	277/43
Launches - Engine Register	162/44
- Fairmile - Engine Operating Hours between overhauls	544/43
- Modifications to circulating water systems	526/43
- Permissible revolutions	543/43
- Type "B" - slipping of	12/44
- Prevention of fire in	238/43; 124/44
Patrol vessels - Klaxon Horns	418/43
Transport Forms	49/44

† Denotes C.C.N.O.

Subject	C.N.O. or C.C.N.O. No.
M - contd.	
Motor vehicles - Naval - accidents	56/44
Movements of personnel - reporting and record of	201/43
N	
Name ships - H.M.A. Shore Establishments	177,629/43;270/44
Napkins - Table and Table Linen - allowances for	317/43
National Security Regulations -	
- Administration of Oaths, etc. to Members of certain Forces	322/43
- Delegations and Authorities to officers holding particular appointments to the R.A.N.	210,375,536/43
- Members of the Forces suffering from mental disorder	455/43
- Orders	89,210,614/43
Naval Armament Depot, Darwin	146/44
Gummounting and Torpedo Stores - Despatch of, to Melbourne	420/43
Store Accounting at certain Shore Establishments - Instructions for	20/43
Accounts - to be transmitted by registered parcel post	355/43
Stores - Accounts of Auxiliary Vessels	73/43
- in D.E.M.S. - Accounting procedure	315/44
Auxiliary Patrol - Concession fares on suburban lines and to and from certain country stations - Victorian Railways	14/43
- Loan Issue of Bluette Combination Suits	36/43
- Personnel - special tropical clothing for	79/43
Naval Base, Darwin - Organization	197,112/43
Board of Administration - Business Member	21/43,105/44
Canteens and Messes - Chocolates and Confectionary for	138/44
Censorship	23,98,177/44
Command - New Guinea Area	167/43
Control Service Officer, Gladstone - appointment of	173/43
Craft requisitioned - Radios fitted in	109/43
Dockyard Police - Summer uniform	287,365,404,462/43
- Issue of Chevrons	190/43
Financial Regulations and Instructions - Art.74 -	
Applications for payment of difference in pay to ratings performing higher duties	365/43
Forces - Form A.M.6 - Medical Examination and Record Form for entry into	455/43
Hospital, Darwin	52/43
Liaison Officer - Australian - Noumea	153/43
Medical History of the War	73/44
Military and Air Force Club, Adelaide	578/43
Officer(s)-in-Charge	495/43
- Brisbane - Correspondence on Naval Armament Store matters	174/44
- Fairfax	133/43
- Hobart - Mails and Correspondence for	362/43
- New Guinea and Port Directors	597/43
Personnel - Admission to Mental hospitals or Receiving Houses	160/44
- Applications from, for release or leave discharge	527/43
† Denotes C.C.N.O.	205/44

Subject	C.N.O. or C.C.N.O. No.
N - contd.	
Naval Personnel - contd.	
- Concession messages	514/43
- Food coupons	266/44
- in Forward Island Bases - bedding for	315/43
- Interstate rail travel by wives and families of	324/43
- Repatriated - liability for further active service	206/44
- Representations by - Procedure	141/43
- Telephone Trunk Line calls by	492/43
Reserve Depots - Ceremonial Band Instruments	409/43
Officers - Confidential reports on	257/44
- Naval Watchkeeping Certificates	256,319/44
- Promotion and confirmation of	301/44
to rank or relative rank of Lieutenant Commander Reserves	359/43
Store Accounting - Documents - Documents	533/43
- Procedure - Frigates	244/44
in H.M.A. Shore Establishments - Bedding issued to Chief Petty Officers, Petty Officers and W.R.A.N.S.	506/43
- Requisitioned vessels	111/43
Accounts and Accounting - Responsibility of Storekeeping Officers and personnel	610/43
- Auxiliary Vessels	499/43
- Transfer of charge between storekeeping officers	231/43
Department, Admiralty, in South-West Pacific - Supply officers of	162/43
- Replenishment of Stocks of consumable naval stores	271/43
Stores - Accounting for - H.M.A. Motor Patrol Boats and other small vessels in which accounts of consumable naval stores are not required to be maintained	632/43
- Consumable in Merchant Vessels commissioned for Naval service - accounting for	366/43
- Ledger Sheets - Amendment of Form A.S.151	246/44
- Custody of	151/43
- Demands for Replenishment of	99/43
- Expended in Naval Works - discontinuance of recovery of cost of material for minor repairs and jobbing from Department of the Interior	404/43
- Interstate and Overseas Shipments and Consignments by rail and air freight to Naval Establishments in Victoria	547/43
- Method of Marking Packages	129/43
- Quality of	316/43
- R.A.N. Establishment of	135/44
- Reduction in Establishment Allowances	69/43
- Stowage in A.M.S. vessels	595/43
Navigation Courses	59/44
- Navigational Courses to qualify for command of an A.M.S. - R.A.N.R. Officers	228/44
Navy Orders - Confidential Commonwealth - Issue of	196/43
- Issue of	1/43
Vehicles - "Knock for Knock" Agreements	108,445/43
Need for greater use of prefixes "Basegram" and "Deferred"	12/43
Netherlands - Expenditure on behalf of - classification	187/44
† Denotes C.C.N.O.	

Subject	C.N.O. or C.C.N.O. No.
N - contd.	
Nets, mosquito	143/43; 212/44
Neutral Countries - Prisoners of War and Personnel Interned in - Pay and Allowance	469/43
New Construction - Equipment and fittings	451/43
Guinea Area - Naval Command	†67/43
Next-of-kin particulars - insertion in September Quarter Ledger	385/43
Night Vision - Dark Adaptation - Supply of Dark Adaptation Goggles	†164/43
Nomenclature of Fuel Oils	474/43
Non-substantive acting rates for V/S I and W/T I - Granting of	239/43
Northern Bases - Ammunition supply to	†145/44
- Personnel serving at	150/44
Operational Bases - Stores consigned by sea or air freight to	167/44
Noumea - Australian Naval Liaison Officer	†53/43
Numbers claimed for victuals in Provision Account with Ship's Ledger - Reconciliation of	283/43
Nurses and W.R.A.N.S. Officers - Agreement for supply of uniforms for	222,530/43

O

Oaths, etc. - Administration of, to members of certain forces - Regulation 63 of the National Security (Supplementary) Regulations	322/43
Observation and controlled mining parties - badges for	96/43
Oerlikon Ammunition Outfits for D.E.M.S.	†56/43
Barrels - Fitting of Spare 20 m.m.	572/43
Guns	523,656/43
- Ammunition for - Pools maintained at ports and outfits to be supplied	†5/43
- Housing - fitted with Mk.XIV Gyro Sights	254/44
Machine Guns - 20 m.m. - Care and maintenance of	121,220/43
- Gauge Striker Protrusion and High Diameter Mark I	395/43
- Handbook and Drill for, B.R.274/41- Amendments to Drill	371/43
- Modification of Shoulder Rest	290/43
- Spare Parts	†28/43
- Tool Loading Magazine - Introduction	123/43
20 m.m. H.E. Lot H.N.C. 13 - Withdrawal	309/44
N.F.E.404 - Ammunition - Withdrawal	310/44
Tracer Lot N.F.H. 2257F - Ammunition - Withdrawal	307/44
10B/45 - Ammunition - Withdrawal	308/44
- Locking of Barrels	179/44
- One Man Cocking Device	261/44
Offences committed by ratings on passage to and before joining H.M.A.S. "Melville"	83/44
Office Machinery - Annual Census	22/44
Machines - Method of Packing	168/44
Officers and Ratings - Waterproof Coats	391/43
- Blankets (Naval Stores) Lost by neglect - charges for	232/43
- Cap Badges	45,244/43
- Dress	†30/44
- Executive - Radar Courses for	†115/44

† Denotes C.C.N.O.

Subject	C.N.O. or C.C.N.O. No.
O - contd.	
Officers - contd.	
- Mess Traps - Gratuitous replacement of	8/43
- Replacement allowances applicable for 1942-43	166/43
1943-44	660/43
- Naval Reserve - Confidential reports on	257/44
- Naval Watchkeeping Certificates	256,319/44
- Promotion of, to rank or relative rank of Lieutenant Commander Naval Reserves	359/43
of Special Branch - Alteration to lacing of jackets, greatcoats and tunics	382,458/43
- R.D.F.	†26/43
- Rehabilitatic. - Appointment and Instruction	213/43
- Procedure in regard to invalidated personnel	336/43
- Travelling with a minimum of baggage - special uniform grant to	139/43
- Uniform - supply of	169,233/43
- Warrant, appointed in lieu of those who have passed Advanced Gunnery Course - Non-specialist Allowance	214/43
Official Memorandum - Prices of clothing, etc. maintained for issue on repayment to Ships' Companies	285/43
- Amendment	31/44
Oil Fuel - Burning of	293/43
Measuring Tapes	270/43
- Monthly Report of consumption of, by A.M.S. Vessels	237/43
- Naval Stocks in Australia	†15/44
- Supplies of, to H.M.A. Ships from Naval and Commercial Oil Fuel Installations	387/43
- Lubricating - for Hall Scott Engines	378/43
- H.M.A. Ships "Kybra", "Wilcannia" and "Reserve"	109/44
Oilers - Fleet Attendant - use by Torres Strait Pilots	†70/43
Oilskin Anti-Gas Clothing - Upkeep and Repair	21/44
Clothing and Rubber Sea Boots - Storage of	530/43; 245/44
Ointment and Anti-Gas Eye Shields - Revision of Allowances	209/44
One and Two Piece Combination Suits - cutting of sleeves	370/43
Operating Tables	278/43
Operators - Teleprinter	62,271/44
O.Q.F. 2-pdr. XIV - Gauges to be maintained at Bases	654/43
4-inch Mark XVI*	122/43
Guns - Extractors	†11/44
Oral Specialist - Consulting to R.A.N.	161/43
Orchestral Bank Instruments - Percentage charge and grants-in-aid	197/44
Orders under National Security Regulations - Protection of Shipping (Accommodation for Defence Personnel) Order	614/43
Registration of Small Vessels	89/43
Regulation 55 of National Security (General) Regulations	89/43
Wireless Stations Control Order - Revocation of certain directions thereunder	393/43; 80/44
Ordnance and Electrical Mechanic Branches	82/44
Artificers (O) - for duties in connection with repair and maintenance of Optical Instruments - introduction of rating	72/43
Organization - Darwin Naval Base	197/43
- Rendering Mines and Bombs safe - round the Australian Coast	240,276,309/43

† Denotes C.C.N.O.

Subject	C.N.O. or C.C.N.O. No.
O - contd.	
Oscillator Unit - Local - Radar Set A272 Mark I	†79/44
Oscillators - Particulars re	†17/43
O.U.5409 - "Rate Book for Naval Stores"	261/43
Outfit Gratuities on change of class of uniform	548/43; 250/44
- Tropical Outfit - Officers	77/43
- Sydney	297,476/43
Payable on promotion from commissioned	
Warrant Officer or Warrant Officer - Lieutenant (Emergency or Retired List)	211/44
Hypodermic, individual Morphine Sulphate Gr. 2 or Omnopon Gr. 2/3 (Tubonic Ampoule or Syrette)	379/43
Outfits - Confidential of Tools - R.M.S. and B.S. Organization	†27/43
Overseers, Principal Naval Overseers and Inspecting Officers - Directions for	569/43
"Overtime and Extra Payment" - Form T.406	372/43

P

P.A.C. and Snowflake Rockets - Precautions when carrying out practices or demonstrations	52/44
Projectors - A.M.S.	†151/44
Rocket failures	6/44
Rockets - A.M.S. Vessels	88/44
Packages containing Asdic Stores - marking	†98/44
Packeted Bone-out Beef	671/43
Packing for Auxiliary Machinery - A.M.S. Vessels of office machines - method	415/43
Paid Acting Non-Substantive Ratings - condition of award by Captain	168/44
Paint Brushes - Care of - Economy in Bristles	586/43
Painting and Drawing Schools Victoria	348/43
D.E.M.S. Gunnery Equipment	138/43
- External and Camouflage - standardization of colour shades and introduction of A1 and A2 Class qualities paint	350/44
Parallel running of steam driven generators in A.M.S. Vessels	400/43
Paravane(s) - Losses by Merchant Vessels - action by D.E.M.S. Staff Officers	54/43
- Replacement or Repair - facilities at Australian ports	76/43
- Towing Ropes - Defensively Equipped Merchant Ships	†118/43
Particulars re Oscillators	6/43
Passages to Australia for dependants of members of the Forces who have married abroad	†17/43
Passports for wives and fiancées - Service personnel overseas	600/43
Patrol Channel Boat "Egeria" - Change of name	157/44
Craft - Explosive charges in	236/43
Vessels - Motor Klaxon Horns	†99/43
Pattern VI Targets - Replacement by "Excellent" Pattern	418/43
172 Lamps for 20-inch Signalling Projectors - maintenance	637/43
474 Stretcher Cots - Supply	†181/43
1900A - Binoculars	243/44
1937 - Web Equipment	35/43
1937 - Web Equipment	137/44
Pay Accounts and Service Certificates of H.M.A. Ships attached to Eastern Fleet	57/44
and Allowances - Prisoners of War and personnel interned in neutral countries	469/43

† Denotes C.C.N.O.

Subject	C.N.O. or C.C.N.O. No.
P - contd.	
Pay - contd.	
- Arrangements - Liaison between Naval and Air Force Officers	141/44
- Deferred - Mobilized personnel	27/44
- On Transfer to another arm of the Services	225/43
- Difference of - Electrical Artificers, Ordnance Artificers and Shipwrights	248/43
Paying off - H.M.A.S. "Arista"	†92/44
"Bombo"	†147/43
"Burrabra"	†127/44
"Emilea"	†66/44
"Forceful"	†136/43
"Gippsland"	†126/44
"Gunbar"	†52/43
"King Bay"	†54/44
"Kweena"	†60/44
"Larrakia"	†49/44
"Maroubra"	†32/43
"Matoma"	†94/44
"Pedare"	†114/44
"Pioneer"	†130/44
"Rathane"	†93/44
"Silver Cloud"	†72/43
"Starfish"	†165/43
"Sylph"	†95/44
"Tasma"	†43/44
"Tongkol"	†131/44
"Topsy A"	†101/44
"Valangen"	†85/44
"Wallaroo"	†40/43
"Wongalere"	†125/44
Paymaster Lieutenant-Commander - Examination for rank of Sub-Lieutenant - Acting - Promotion from the lower deck	212/43; 202/44
Payment of Allowance - Higher Fire Control	496/43
Contractors' claims in connection with funerals	180/43
Dependant Allowance - "Dependent Female" - Formerly termed "de facto wife"	555/43; 250/44
Fares of relatives attending funerals of deceased service personnel	668/43
Pilotage of H.M.A. Ships and Vessels	274/44
Traders' Account for Supplies to H.M.A. Ships	†151/43
Percussion Detonators - Watertight, Mark VII Lot 141, B.R.8/41 - Withdrawal from service	534/43
Fuzes D.A. No.230 - Marks to be used for guns in twin mountings	41/44
Periodical examination of explosives in shore establishments other than Naval Armament Depots	†65/43
Permissible revolutions - Fairmile Motor Launches	487/43
Personnel appointed or drafted to R.A.N. Ships serving in the Eastern Fleet - Medical History - Documents of	343/43
at sea - Emergency ration for - supply of water bottles	†129/43
- Awards and Honours to Naval	136/44
- Deaths from Disease or Injury - information to be forwarded	12,83,211,355, 494/43; 200,288/44
- Deceased - Cremation of	229/43
- Letters found amongst effects of	323/44
	36/44

† Denotes C.C.N.O.

Subject	C.N.O. or C.C.N.O. No.
P - contd.	
Personnel - contd.	
- D.E.M.S. - Liability for Pay etc.	159/43
- Despatch of, to Sydney for Medical Observation	258/44
- Discharged - Clothes rationing	118/43
- Rehabilitation Procedure for	14/44
- Drafting - Malaria Control	118/44
- Employment of, other than officers - rendering mines safe	251/44
- For Discharge - Applications from	205/44
- Found Medically Unfit - drafting categories	24/43
- In Forward Island Areas - special clothing issue for	623/43;
	224,282/44
- Naval - Food Coupons	266/44
- In Forward Island Bases - Bedding for	315/43
- Liability for further active service	206/44
- Procedure in regard to invalided - Rehabilitation	
Officers	336/43
- Record of and reporting movements of	201/43
- Half-yearly reports on A/S equipment	†148/44
- Release of - for the dairying industry	304/44
- Representations by Naval - Procedure	†41/43
- R.M.S., for Service Afloat	158/44
- Sentenced to detention	5,341/43
- Serving at Northern Bases	150,321/44
- Suffering from Mental Disorder - Certification	2/43
- Technical information - promulgation to	3/43
- Training of - Asdic installations Types 144/5	†70/44
- Travelling by train - damage to railway property and	
accidents sustained by members of the	
services	200/43
- Issue of Mess Gear and Blankets to	170/44
- To or from Darwin by the Overland route -	
Issue of gear	134/43
- In uniform - transportation of	37/44
- Unclaimed effects of	216/43
Petty Officers - R.A.N.R. - Advancement to Chief Petty Officer	290/44
Photographic material for use in H.M.A. Ships and Establishments	8/44
Records of H.M.A. Ships	641/43
Photographs for Intelligence purposes	147/43
Photography - control of cameras - use in Northern Territory and	
other Advanced Bases	436/43
Pillar Box Mountings - Failure of 2" U.P.	377/43
Pillow Slips and Sheets - Conservation of	215/44
Pilotage - Payment to H.M.A. Ships and Vessels	†151/43
Pilots - Torres Strait - Use by Fleet Attendant Oilers	†70/43
Pioneers' Tools for Landing Parties	558/43
Pistols - Depth Charge - Diaphragms I.R. St.No.6067 - Precautions	267/43
- Test of "Safe"	
Positions	419/43
- Mark(s) VII - IX: Locking Screws	124/43
- VIII* - Distribution	†12/43
- VIII* - VIII**	†10/43
- (M) Type B - B* - Introduction of	
"Klingerite" Washers	441/43
- Routine Tests	421/43
- Thrower - Spares (A.F.O.1934/43)	501/43
- Revolver - Losses of	18/44

† Denotes C.C.N.O.

Subject	C.N.O. or C.C.N.O. No.
P - contd.	
Pitting in Engine Room Bilges - A.M.S. Vessels	†69/44
Plates - Earthenware	81/43
Plugs Fuzehole 2" Nos.11 and 14 - Return of	678/43
P.M.G. Certificates - Eligibility of Telegraphist Ratings	
for exemption in certain subjects of the examination for	75/44
Polarized Sun-Glasses - Replacement by Pattern 4074 Anti-Glare	
Spectacles	125,281/44
Police - Civil - Reports to - misappropriation of Government	
Stores	72/44
- Naval Dockyard - Summer uniform	462/43
Port Adelaide - refit of A.M.S. Vessels at - replenishment of	
Naval Stores	34/44
Port Directors	526/43;148,199,
	317/44
and Naval Officer-in-Charge, New Guinea	597/43
Moresby - Marking of Cases, Packages, etc.	320/43
- Ship's Water Supply at	363/43
Postal Articles - Treatment of Undeliverable	351/43
Postmen and Orderlies - Correspondence	259/44
Powder - Bleaching Powder for H.M.A. Establishments - under	
conditions of actual gas warfare in Australia	†165/43
Powers of arrest under the National Security Act, 1939-1943 -	
Exercise of	22/43
Practice Expenditure - Depth Charges	†122/44
Practitioners, Civilian - Rates to be paid for Services	
afforded by - Medical Charges	218/43
Precautions when carrying out practices - demonstrations with	
P.A.C. and Snowflake Rockets	52/44
in hot climates - Depth Charges	75/43
Prefixes "Basegram" and "Deferred" - Need for greater use of	†2/43
Preservation of Health - General Hygiene and Sanitation -	
including the prevention of malaria	269/44
Tools	125/43
Press Advertisements	294/43
- Communications with	133/44
Prevention of bigamous marriages	274/43
Deterioration of kits in Northern Areas	443/43
Fire in Motor Boats	238/43
Spread of Malaria	275,520/43
X-ray burns	456/43
Prices of Clothing, etc., maintained for issue on repayment to	
Ship's Companies	285,575/43
- Amendments of Official Memorandum	31/44
Principal Naval Overseers, Overseers, and Inspecting Officers -	
Direction for	569/43
Printed Forms	313/44
Prisoners of War and Personnel interned in Neutral Countries -	
Pay and Allowances	469/43
Private Firearms	229/43
Procedure in regard to invalided personnel - Re-habilitation	
Officers	336/43
- Representations of Naval Personnel	†41/43
Professional examination - Warrant Electrician, R.A.N.	570,602/43
Engineers and Warrant	
Mechanicians	286/43
Promotion and Confirmation of Naval Reserve Officers	301/44
from Lower Deck - Acting Paymaster Sub-Lieutenant	496/43

† Denotes C.C.N.O.

Subject

C.N.O. or
C.C.N.O. No.

P - contd.

Promotion - contd.		
- to Temporary Warrant Rank	119/44	
Warrant Writer and Warrant Supply Officer - Conditions	289/44	
Propellant - Flashless	†144/44	
Propeller Shafts - A.M.S. Vessels	†62/44	
Prophylactic Centres - control of venereal disease	†132/44	
Outfits	†114/45	
Prophylaxis - Tetanus	87/44	
Proprietary Medicines, Sale of, in Canteens	329/45	
Protection of L.L. Sweep Switchboards - A.M.S. Vessels fitted with L.L. Sweeping Equipment	25/45	
Shipping (Accommodation for Defence Personnel) - Order and Authority thereunder	614/45	
Protective Clothing	231/44	
For Fire and Repair Parties	280/45	
Goggles for Sun Sector Lockouts - Introduction	459/45	
Loan Clothing for H.M.A. Boom Depots	349/45	
Provision - Life Saving Appliances	492/45	
Provisions - Accounts for - Necessity for prompt payment	217/44	
- Canned - Warranty Period of	68,235/44	
- Fresh - Contract Rates at Melbourne	101/44	
- Supply of, at Melbourne and Sydney	194,511/45	
- Maintenance of Adequate Stocks	206/45	
or other Victualling Stores - Report of Survey - Form A.S.330 - Rendition of	127/44	
- Revised Fixed Issuing Price List for	565/45	
- Supplementary Fixed Issuing Price List for	564/45	
- Warranted	128/45	
Ptergium - Candidates suffering from, to be medically rejected	544/45	
Pulmonary Tuberculosis - Active - Members of the Forces suffering from	485/45	
Pumps - Reciprocating - Shuttle Valves - Heat Treatment	107/44	
- Stirrup - Care of Rubber Hose	142/45	
Purchase of Naval Stores - Introduction of Form A.S.133Z in R.A.N. Shore Establishments and Base Depots	609/45	
Wreaths	364/45	
Pyjama Suits	613/45	
Pyrotechnics and Rockets, Signal - Ammunition - Star Shell - All Calibres - Minimum Range at which satisfactory functioning can be expended	193/44	

Q

Quadruple Carriers, Ammunition Carriers, Shell Quadruple - Transfer to Gun-mounting Department	182/45
Qualification(s) - Advancement to Chief Shipwright	322/44
of Specialists	447/45
Qualified Officer "Status" - Full and Modified Grant of	74,152/44
Quality of Naval Stores	316/45
Quarter Bills - Amendments	189/44
Quarterly Return of Temperatures of Storage of Cordite - Forms S.1147a - non-rendering	†100/44

† Denotes C.C.N.O.

Subject

C.N.O. or
C.C.N.O. No.

Q - contd.

Q.F. 4" Mark XVI* Guns	266/43
XIX Guns - Bore Telescopes for	269/43

R

Radar - Australian Type - Authorized Allowances of Accessories (Test Equipment)	140/44
- Beacons	†141/44
Branch - Advancement	519/43;84/44
Courses for Executive Officers	†115/44
Equipment - Allocation of	†142/44
- Spares for U.S.N. Type	†35/44
- Escort Vessels fitted with - Modification to Bridge Chart Table	†134/44
in A.M.S. Vessels	†9/44
Instructional Films	†153/43
Offices - Fire Extinguishers	416/43
Operators - Care of Eyes	†113/43
Personnel - Standards of Vision	†92/43
Ratings	249/44
Reflector - Euston Reef Beacon	†119/44
Security	†82/44
Set A.272 Mark I Local Oscillator Unit	†79/44
Sets - Spares for - Particulars required in demands	591/43
Stores - Custody, Issue and Accounting at Ports other than those at which a Naval Store Office is established	477/43
Transponder, Instructions for fitting at R.A.N. Bases - Type 253	†107/44
Type(s) 253	†96/44
271/3, A.272, Flywood Lanterns - Maintenance	†38/44
A.272 Mark I, Improved Valve Type NTA 98	†34/44
Obsolence of Aerial, Transmitter - Modulator, and Aerial Control Units	†87/44
286 P/Q - Modification to Aerial Training System A/S 1 and A/S 3	†81/44
A.286 P/Q - Interference with W/T and R/T Reception - Modification for Listening Watch	†48/44
†113/44	
A.286 Q	†88/44
W/T, A/S etc. Equipment Establishment List	311/44
Radio Mechanic Branch - Adoption in the R.A.N.	414/43
Sets fitted in Requisitioned Craft, etc.	109,160/43
Rail Accommodation - Adelaide to Melbourne	97/44
Travel Interstate - Wives and Families of Naval Personnel	324/43
Railway Property, Damage to and accidents sustained by members of the Services - Personnel travelling by train	200/43
Warrants - Exchange of, for Tickets	342/43
R.A.N. Accounting Officer, Kilindini	†91,249/43
Armament Depot, Fremantle and Mine Depot, Byford	†89/43
Auxiliary Services, Ratings - Khaki Tropical Clothing	461/43
Destroyers - Accounts	237/44
Establishments of Naval Stores	135/44
Higher Educational Test - Results - October 1942	104/43
- April 1943	338/43
- October 1943	156,248/44
Pattern Haze Screens - Modification	134/44

† Denotes C.C.N.O.

Subject	C.N.O. or C.C.N.O. No.
R - contd.	
R.A.N. Personnel - Honours, Decorations, Awards	355/43
- U.S.N. arrangements for supply of common and other Naval stores	†105/43
Range Tables, Gun and Gun Mounting - O.U. Books and Books of Reference	†68/43
R.A.N.V.R. Able Seamen - Allocations of, to General Service ..	176/44
and R.A.N.V.R. Officers - Confirmation and Provisional Promotion in time of war	538/43
- Watchkeeping Certificate	256,519/44
Officers - Confidential Reports upon	257/44
- Navigational Course to qualify for Command of an A.M.S. ..	228/44
- Watchkeeping Certificate	256,519/44
Petty Officers - Advancement to Chief Petty Officer	290/44
R.A.N.V.R.(S), Officers - Promotion to Sub-Lieutenant	581/43
R.A.N.V.R. Special Branch	224/43
Telegraphists - Advancement of	429/43
"Rate Book for Naval Stores" - O.U.5409	261/43
Rates of Treatment in approved Private Hospitals	305/44
Ratings - Advancement of, during the War	376/43
- Serving in Small Ships	413/43
- Training in Combined Operations	449/43;221,292/44
and Officers - Waterproof Coats	391/43
- Blue Caps for	191/43
- Claim Forms for Compensation for Total Loss of Uniform - Forms A.S.103y and A.S.103z	242/44
- Compensation for Loss of or Damage to, Uniform and Clothing Articles	204/43;147/44
- Controlled and Observation Mining - Badges	7/44
- Convoy Signal	49/43
- D.E.M.S. Gunnery - Badges	93/44
- Disposal of - after sentence of detention or imprisonment ..	250/43
- Engine Room - Examination of - Results	198/43
- April, 1943	437/43
- September, 1943	13,191/44
- Higher Gunnery - Qualification at Sea	228/43
- Kits, drafted to Darwin, Thursday Island and New Guinea Areas	263/44
- Free - Issue on Entry	154/44
- Modification	172/43
Made-to-Measure Uniforms - Contract at Adelaide	257/43
Brisbane	522/43
- Metal Cap Badges for Class III	475/43
- Offences committed by - on passage to and before joining H.M.A.S. "Melville"	83/44
- Paid Acting Non-Substantive - Condition of Award by Captain Performing Higher Duties - Application for payment of difference in pay to - N.F.R. & I. rt.74	586/43
- Radar	365/43
- R.A.N. Auxiliary Service - Khaki Tropical Clothing	249/44
- R.A.N.V.R. - Transfer to the Permanent Naval Forces (Seagoing) Recommended for Service in D.E.M.Ships	461/43
- R.N. on Loan to the R.A.N. - Disposal of Service Certificates on reversion	498/43
- Selection of, for Divers	65/43
from the Lower Deck - Temporary Commissions	190/44
Serving in Northern Areas - Additional Supply of Khaki Tropical Clothing to	149/44
.. ..	412/43
.. ..	170/43
† Denotes C.C.N.O.	

Subject	C.N.O. or C.C.N.O. No.
R - contd.	
Ratings - contd.	
- Supply	484,571/43,17,172/44
- Telegraphist	75/44
Trained in Combined Operations - Advancement of ..	449/43;221,292/44
- V/S and W/T - Training and Advancement during the war ..	323/43
- Young Seamen in H.M.A. Ships - Training of	48/43
Rationing - Clothes	480/43
- Bed Linen	183/44
- Food and Food Economy	265/44
Rations - Emergency - Operating from H.M.A. Ships	67/44
R.D.F. Officers	†26/43
Re-arming with 4" XIX Guns on H.M.L.A.XXIII* Mounting - H.M.A.Ships	260/44
Recall of Ships' Companies from Short Leave	450/43
Reciprocating Main Engines - Frigates	†53/44
Recoil Pumps - Shuttle Valves - Heat treatment	107/44
Cylinder Liquid - Gun Mountings - Test of	192/44
Tool Spring, Thompson Sub-Machine Guns 0.45-in. - Instructions for use	†44/43
Recommendations for Torpedo Non-Substantive Rates	97/43
Reconciliation of Numbers claimed for victuals in Provision Account with Ship's Ledger	283/43
Reconditioned Q.F. 2 pdr. H.E. H.V. Ammunition	†143/44
Record Form and Medical Examination for Entry into the Naval Forces - Form A.M.6	455/43
of, and Reporting Movements of personnel	201/43
Naval Store Ledger Keepers - Introduction of Form A.S.155x ..	298/44
Records - Cordite - Maintenance on board H.M.A.Ships	89/44
Rectifier Units, Patt.No.Aust.A.846	†122/43
Reduction of Mails	137/43
Fire and Smoke Risks in H.M.A. Ships - C.A.F.O.2363/42 - Application in the R.A.N.	†45/43
Kits in H.M.A. Ships and Shore Establishments	241/44
Reductions in Establishment Allowance - Naval Stores	69/43
Reeving of Beackets - Clips Cartridge No.25	164/44
Refresher Escort Training Organization	†55/44
Refrigerating Plant for Cold Room - A.M.S. Vessels	210/44
Register Sheets for C.B. Form "R"	665/43
Registration - Confidential correspondence	300/44
Regulations and Instructions for the R.A.N.V.R.	479,579/43
W.R.A.N.S.	30/43
Rehabilitation Officers - Appointments and Instructions ..	213,601/43
Procedure for Discharged personnel	14/44
Relatives attending funerals of deceased service personnel - Payment of fares	274/44
Release or Leave - Applications from Naval personnel for ..	527/43
of personnel for the Dairying Industry	304/44
Re-naming - H.M.A.S. "Vigilant"	285/44
- H.M.A.S. "Viking"	286/44
Rendering Mines and Bombs safe - Organization round the Australian Coast	187,240,276,309,617/43
Safe - Employment of Personnel other than officers of Forms S.1148(h),(i) and (j) - Failures of Armament Material and Ammunition	251/44
.. ..	294/44
Rendition of Form A.S.288A - "Annual Diving Return"	110/43

† Denotes C.C.N.O.

Subject	
R - contd.	
Renovation of Gold Lace and other articles made of Gold Bullion	9/43
Repainting of A.M.S. Vessels	110/44
Repair of Cartridge Cases	150/43
Repatriated Naval Personnel - Liability for further active service	206/44
Repatriation benefits for Members of the Naval Forces and their Dependants	615/43
Repayment Clothing on Tenders	664/43
Issues of Materials - Uniform and Clothing supplies	171/44
Replacement Allowances applicable for 1942-43 - Officers' Mess Traps	166/43
or Repair - Paravanes - facilities at Australian Ports	†118/43
Parts - W/T Equipment of Australian Manufacture	473/43
Replenishment of Naval Stores by A.M.S. Vessels refitting at Port Adelaide	34/44
Reporting Mines washed ashore - Awards for	107/43
Movements of personnel and record of	201/43
Reports - Ammunition - 20 m.m., 40 m.m., 2-pdr. - 20 m.m. Oerlikon H.E. - Withdrawal of certain Lots	142/44
- Confidential, on Naval Reserve Officers	257/44
- Firefighting Equipment Trials	161/44
- Half-yearly on Asdic Equipment	†19/43
- Record of Personnel	†148/44
- Loss of Gas Cylinders	67/43
- of Survey on provisions or other Victualling Stores - Form A.S.330	127, 223/44
on Failure of Gun Armament material	500/43
- Periodical Material - Echo Sounding Equipment	†16/43
- Rendering of - Mines Washed Ashore	45/44
- Stocks of Ammunition	166/44
- Weekly stock - Depth Charges and Associated Stores	†46/43; †47, †64, †72, †135/44
Repositioning of Ballast - A.M.S. Vessels - use of Forepeak - Use of after Trimming Tank	†142/43
Representations by Naval Personnel - Procedure	†41/43
Requisitioned Naval Craft, etc. - Radio Sets fitted in	160/43
Ships - Commercial Type Pyrotechnics landed from	588/43
Vessels - Naval Store Accounting	111/43
- Stores remaining on board on termination of Charter	574/43
"Reserve" - H.M.A.S.	†102/43
Reserves of Depth Charges at Australian Ports and in A.S.I. Ships	†37, †66/43
Gun Ammunition at Australian Ports and in A.S.I. Ships	†6, †100/43
Respirators - Anti-gas - Containers	†145/43
- Issues to W.R.A.N.S.	†178/43
- Losses of	353/43
- Tubes connecting	†75/43
Responsibility of Storekeeping Officers and Personnel - Naval Store Account and Accounting	610/43
Restriction in use - Attache Cases	432/43
Results - Educational Test I - December, 1942	71/43
- March, 1943	272/43
- June, 1943	468/43
- September, 1943	81/44
- December, 1943	203/44
- March, 1944	318/44
- Examination of - Engine Room Ratings - November, 1942	91/43
- September, 1943	13, 191/44

† Denotes C.C.N.O.

Subject	
R - contd.	
Results - Examination of - contd.	
Sick Berth Staff - May, 1943	483/43
- November, 1943	104/44
- Higher Educational Test - October, 1942	104/43
- April, 1943	338/43
- October, 1943	156/44
Retention of Kit on Discharge	549/43
Return of Empty Gas Cylinders	48/44
Stores to Victualling Yards	188/43
Vessels, Lighters, Pontoons, Motor Launches and Boats	642/43
Revised Fixed Issuing Price - List of Provisions	563/43
Revision of Forms A.S.98 and A.S.98A	126/43
Revocation of certain orders under the Wireless Stations Control Order	393/43; 80/44
Revolver, Ball Cartridge S.A. .455" - Mark II Cartridges to be replaced by Mark VI	181/43
Pistols - Losses of	18/44
Revolvers - Accidents	86/44
R.F.A. "Bishopdale" - fitted for oiling at sea by British Buoyant Hose Method	†71/43
Ribbons - Cap	299/43
- Medal - Wearing with Tropical Dress	312/44
"River" Class Corvettes - Reclassified as "Frigates"	†42/43
R.M.S. and B.S. Equipment - Afloat	†13/43
Organization - Confidential Outfits of Tools	†27/43
Parties - Disposal of Mines Rendered safe by	164/43
Personnel for Service Afloat	158/44
Reports on Form S.1516	163/43
R.N. Ratings on loan to the R.A.N. - Disposal of Service Certificates on Reversion	190/44
Ships and Authorities - Address of	543/43
Rockets - Apparatus A.D. - Type D - Restriction on Lots 452, 480, 511 and 513	399/43
- Illuminating - 3½lb. - Prematures	40/44
- P.A.C. - A.M.S. Vessels	88/44
and Snowflake - Precautions when carrying out Practices or Demonstrations	52/44
- Failures	3/44
- Target Practice Mark I*, Lots 129 and 144 - withdrawal - Reports	320/44
2" U.P. Failure	121/44
Roller and Ball Bearings - Procurement	4/44
Rope - Soled Shoes	117/43
for H.M.A. Motor Patrol Boats and Naval Auxiliary Patrol Boats - Loan issue of	88/43
Route Order and Travelling Expense Claim - Form A.S.542	135, 433/43
Royal Australian Naval Volunteer Reserve - Regs. and Instrns. for Women's Services - Uniform and Clothing Authorized Kit	479/43
375, 424, 612, 633/43; 55, 103, 128/44	
Nursing Service - Wearing of Shoulder Straps	175/44
Netherlands Navy in Australia - Telegrams for	50/44
South Yarra Lawn Tennis Club, Melbourne - Honorary Membership for Officers	112/43
R/T Interference - A/S Equipment in M/Ls	†61/44
Sets - V.H.F. - Fitting of - Alteration and Addition	†123/43

† Denotes C.C.N.O.

Subject

C.N.O. or
C.C.N.O. No.

R - contd.

R/T Sets - V.H/F. - contd.	
- Installation of - Intercommunication - Mixed Squadrons - Alteration and Addition	†95/43
R.U. Ammunition - Excessive Temperatures of	186/43
Rubber Sea Boots and Oilskin Clothing - Storage of	530/43; 245/44
- Shortage	68/43
Rudders - Fairmile	293/44
"Rushcutter" H.M.A.S. - Organization	102/43

S

Sabotage - Anti-sabotage measures by H.M.A. Ships in Harbour ..	†76/43
Safeguarding of personal money - Form A.S.23	106/43
Safety Rail - Training - 20 m.m. Oerlikon	7/43
Sale of Proprietary Medicines in Canteens	329/43
"Salt" Journal and "Current Affairs Bulletin"	155/43
Salvage of Condemned Unserviceable etc. Stores - Army Salvage Service	267/44
Sanitation and General Hygiene - Preservation of Health, including the Prevention of Malaria	269/44
S.A. .303" Cartridges - Land Service	230/43
Scale "E" - Chest of Medical Equipment - Accounting Procedure	685/43
Schools - Drawing and Painting - Victoria	138/43
Scientific Section - Tropical	271/44
Sea Boots and Oilskin Clothing - Rubber - Storage of	530/43; 245/44
Sickness - Cases of - Medical Survey on	†137/43
Seamen's Mess Utensils - Gratuitous Replacement of	8/43
Seaward Defences - Addresses	†22, †60, †110, †150/43; †156/44
Secret and Confidential Books - Instructions for the Account- ing, Custody of etc.	†170/43
Correspondence - Instructions re Acknow- ledgment, Disposal, etc.	†56/44
- Security of	†99/44
Selection for Accountant Officers' Training Course	497/43
of Ratings for Divers	149/44
Serge - Diagonal	332, 565/43
Service Afloat - R.M.S. personnel for	287/43
- Definition of - 1939-43 Star - Persons eligible	201/44
Buildings - Terne Iron - use of	651/43
Canteens	165/43
Certificates and Pay Accounts of H.M.A. Ships attached to Eastern Fleet	57/44
- Examination of	630/43
- Inspection of	556/43
- On reversion - disposal of - R.N. ratings on loan to the R.A.N.	190/44
Shale or Colliery refuse as Ballast in Ships carrying Explosives - Carriage of	158/43
Sheets and Pillow Slips - Conservation of	215/44
Shipment of Mining Stores - Case Markings	216/44
Stores to Milne Bay	403/43

† Denotes C.C.N.O.

Subject

C.N.O. or
C.C.N.O. No.

S - contd.

Ships carrying Explosives - Carriage of Shale or Colliery refuse as ballast	158/43
Fitted with "L.L." and "S.A." Sweeps - Care and Maintenance Reports	†81, †127/43
Funds	219/43
- Landing - Infantry - Administration	†117/44
Library Books - Purchase Price Limit	223/43
- Supply to Small Ships	207/43
Log and Deck Log - Instructions for compiling	337/43
Not in Commission	†1/43
- Small - Supply Assistants	482/43
Water Supply at Port Moresby	363/43
Shipwrights, Electrical Artificers, Ordnance Artificers - Difference of Pay	248/43
Shoes - Galley for Cooks - W.R.A.N.S.	77/44
- Gymnastic for W.R.A.N.S.	19/44
- Rope-soled	117/43
Shore Establishments and H.M.A. Ships - Reduction of Kits in ..	241/44
H.M.A. - Name Ships	177/43; 270/44
- Payment of Allowance for Charge of Naval Armament Stores	374/43
Weekly Report of Stock by - Ammunition - Form A.O.52	326/44
Short Leave - Recall of Ship's Companies from	358, 450/43
Range A.A. Weapons - Eyeshooting Sights	148/43
Shortage of Rubber Sea Boots	68/43
Shorts - Tropical Khaki - Additional Sizes	78/43
Shoulder Straps - Wearing of	175/44
"Shropshire" H.M.A.S.	†47/43
Shuttle Valves of Reciprocating Pumps - Heat Treatment ..	107/44
Sick Berth Branch - Candidates for Examination for Higher Rating in Manuals and Addenda - B.R.888 and B.R.888(1)	64/43
Staff - Examination Results - November, 1942	676/43
- May, 1943	91/43
- November, 1943	483/43
Signal and Cypher Logs - Disposal of	104/44
Card, 1942, - A.B.R. 232 - Issue to Ordinary Seamen V/S	†44/44
Letters of British Ships	288/43
Traffic	321/43
Signals - Harbour, to denote Air Raid Warnings	207/44
"Silver Cloud" H.M.A.S. - Paying off	†23/43
Skilled Tradesmen - Employment and Hours of Work	†72/43
Sleeves and Torches for Inflatable Lifebelts - Life Saving Equipment	65/43
Small Arms and Close Range Weapons - Precautions	212/44
- Establishments for Shore Bases	467/43
- Live Throwers, Shoulder, Coaton - Replacement by Rifles M.L.E. Line Thrower	†20/44
- Revolvers - Accidents	123/44
- Rifles and Sub-Machine Guns - Allowances	86/44
Kitbags	†138/44
Ships Ammunition Outfit of - Arrangements for Periodical Exchange, Examination etc.	258/43
and D.E.M.S. Ships - Handling Explosives in	325/44
Soda Ash - Use of, in lieu of Soda Crystals	397/43
Spare Parts supplied, for O.Q.F.4" Mark XVI* - Fitting of ..	113/44
Spares - Depth Charge Thrower Pistols	†93/43
for Radar Sets - Particulars required in demands	65/44
	591/43

† Denotes C.C.N.O.

Subject

C.N.O. or
C.C.N.O. No.

S - contd.

Spares for U.S.N. Type Radar Equipment..	†33/44
Special Badge - Bomb Disposal Squads	17/43
Branch - Officers of - Alteration to Lacing, Greatcoats and Tunics	458/43
- R.A.N.V.R.	224/43
Clothing for Mosquito and Sandfly Infested Areas	168/43
Issues for personnel in Forward Island Areas	625/43;224, 282/44
Issue(s) - Boots to, Ship's Cooks and Officers' Cooks	460/43
- Clothing to D.E.M.S. Ratings - Lifesaving Waistcoats and Torches	505/43
Tropical Clothing for N.A.P. Personnel	79/43
Uniform Grant to Officers travelling with a minimum of Baggage	139/43
Specialist(s) - Consulting Oral, to R.A.N.	161/43
- Qualification of	447/43
Spectacles and Dentures - Loss through active service	347/43
- Anti-glare - Pattern 4074 - Supply	30,125,281/44
Speeds, minimum, of Ships and Depth Charge Settings for dropping Depth Charges	†9/43
Sperry Commercial Gyro Compass Equipment - Maintenance	31/43
Mark XIV - Mod.I Gyro Compass - Incorrect fittings of transmitter connecting cables	314/44
Spirit Duplicators - use of Methylated Spirits	407/43
Split Charge Cases, Depth Charges with - Reports required	162/43
Spur for Additional Signal Halliards - A.M.S. fitted for Mine-sweeping - Alteration and Addition	†118/44
Stability - A.M.S. Vessels	†69/43
Star (1939-43) and South Africa Star and Mention in Despatches	466/43
Emblem	201/44
- Persons eligible, and definition of "Service Afloat"	†128/44
Shell Allowances	193/44
Pyrotechnics and Rockets, Signal - Ammunition - All Calibres - Minimum Range	10/44
Statutory Rules governing the Administration of Women's Services - R.A.N.	15/43
Steam Drenching arrangements in Engine Room and Boiler Room of A.M.S. Vessels	†123/44
Driven Boiler Room Fan Engine - Vibration of - A.M.S. Vessels	512/43
Steel and Wood Blocks	417/43;181/44
Chests for A.M.S. Vessels	21/43
Custody of Confidential Books in Fairmiles	142/43
Stirrup Pumps - Care of Rubber Hose	†15/44
Stocks of Naval Oil Fuel in Australia	367/43
, Taps and Dies - Adoption of Commercial Type for use in H.M.A.Ships and Establishments	507/43
Stop Watches - Reduced Allowances	†100/44
Storage of Cordite - Quarterly Return of Temperatures of - Non-Rendering - Form S.1147a	530/43;245/44
Storage of Oilskin Clothing and Rubber Sea Boots	610/43
Store Accounts and Accounting - Naval - Responsibility of Storekeeping Officers and Personnel	355/43
- Naval Armament - Registered Parcel Post	231/43
- Transfer of Charge between Store-keeping Officers	499/43
- Auxiliary Vessels	

† Denotes C.C.N.O.

Subject

C.N.O. or
C.C.N.O. No.

S - contd.

Storekeeping, Naval - Replenishment of Stocks of Consumable Naval Stores	271/43
Store - Naval - Accounting Procedure - Frigates	244/44
Stores and Equipment returned to Victualling Yards - Condition of	167/43
- Canteen, for H.M.A.Ships	153/43
- Care of	282/43
Condemned, unserviceable, etc. - Salvage of - Army Salvage Service	267/44
- Government - Misappropriation of - Reports to Civil Police	18/43;72/44
- Medical - Form A.M. 177G Medical Store Accounts for Scale "C"	222/44
- Mining - Shipment of - Case Markings	216/44
- Naval Armament - Accounting for	385/43
- Gunmounting and Torpedo - Despatch of to Melbourne	43/44
- In D.E.M.S. - Accounting Procedure	315/44
Consumable, in Merchant Vessels Commissioned for Naval Service - Accounting for	366/43
- Custody of	151/43
- Demands for Replenishments of	99/43
- Incorporated in W/T, A/S, Radar etc. sets - Modification of Procedure for Accounting for	139/44
- Losses of, from H.M.A.Ships, due to theft during refit etc. at H.M.A. Naval Yard, Sydney	406/43
- Method of marking packages	129/43
- Purchases of - Introduction of Form A.S.133Z in R.A.N. Shore Establishments and Base Depots	609/43
- Quality of	316/43
- Reductions in establishment allowances	69/43
- Replenishment by A.M.S. Vessels refitting at Port Adelaide	34/44
- Ventilation of - A.M.S. Vessels	†51/43
- Permanent Naval - Combustion Cones for Boilers	91/44
- Radar - Custody, Issue and Accounting at Ports other than those at which a Naval Shore Officer is established	477/43
- Remaining on Board requisitioned vessels on termination of Charter	574/43
- Return of, to Victualling Yards	188/43
- Returned to the Royal Edward Victualling Yard	405/43
- Shipped - Discrepancies in	51/44
- Supply of Naval, Naval Armament and Naval Victualling for Naval Drafts	551/43
- U.S.N. - R.A.N. - Arrangements for supply of common and other Naval Stores	†105/43
- Victualling - Demands for - Economy in use of Forms - Delivered to H.M.A. Ships in a deficient or damaged condition - Accounting for consignments of	256/43
Stretcher Cots - Pattern 474 - Supply	243/44
Sub-Lieutenant - Promotion to - R.A.N.R. (S) Officers	381/43
- Machine Guns - Thompson 0.45" - Tool Recoil Spring - Instructions for use	†44/43
Submissions to Naval Board by Tenders	94/43
Subsistence of Persons in Civil Gaols	227/43
Suitcases and Small Blue Drill Kit Bags - Variations in Kit	254/44
- Labelling and Marking of	57/43

† Denotes C.C.N.O.

Subject

S - contd.

Suits - Bluette Combination - Issue to Supply Ratings ..	648/43
- Brown Dungaree Combination - Loan Issue to Officers ..	58/43;112/44
Summer Uniform - Naval Dockyard Police - Issue of Chevrons ..	190/43
Sun Glasses - Polarised - Replacement by Pattern 4074 Anti-glare Spectacles	125,281/44
Helmets and Khaki Covers	192/43
Reflecting Device for H.M.A. Ships	35/44
Sector Lookouts - Protective Goggles for - Introduction ..	459/43
Supplementary Fixed Issuing Price List for Provisions	564/43
Supplies of Citric Acid for Canteens	281/43
Oil Fuel to H.M.A. Ships from Naval and Commercial Oil Fuel Installations	387/43
- Shortage of - China, Earthenware and Glassware ..	532/43
- Uniform and Clothing	189/43
Supply Assistants for Small Ships	482/43
of Anti-glare Spectacles Pattern 4074	30/44
Bread at Melbourne	551/43
Canteen Stores	283/44
Civilian Clothing to Members of the Naval Forces on Discharge	390/43;214/44
Coal for H.M.A. Ships - Procedure	32/44
Fresh Provisions at Melbourne and Sydney - Contracts for	194,356/43
Liquid Human Serum	85/43
Low Power W/T - R/T Transceiver Installation - Type R.C.8	†30,†35,†87/43; †12,†37/44
Naval Armament, Naval and Victualling Stores for Naval Draughts	551/43
Officers' Uniforms	169,233/43
Rubber - Exhaustion of	296/43
Spectacles - Delegation of authority	297/44
Stores for Anti-Malarial Measures	15/44
Towels in Victorian State Hostels	463/43
Victualling Stores for A.M.S. Vessels, Frigates, Fairmiles, and H.D.M.Ls. on Commissioning	673/43
Officers of the Naval Store Department, Admiralty in the South West Pacific	†62/43
Rating (A.S.) - New Rating	17/44
Ratings	484,571/43
and Junior Writers - Typewriting Experience ..	172/44
- Issue to - Suits, Combination, Bluette	648/43
Suppressive Treatment (Prophylaxis) for Malaria, with Atebrin	240/44
Surface Craft - Attacks by, on Enemy Submarines	†3/43
Surplus Naval Stores at Commercial Yards	384/43
Survey on Provisions and other Victualling Stores - Reports of Form A.S.350	127,223/44
Survivors - Blankets, Duffel Coats and Towels for	508/43
- Issues of Clothing to	529/43
Suspension of Adjustments between War Departments and State Railways	554/43
Inter-Departmental Adjustments in War Time	429/43
Sweepers "L.L." - Security of Floats to Electrodes	†20/43
Swords and Belts for Masters-at-Arms	346/43
- Naval	242/43
Sydney Command	11,537/43
Detention Quarters	487/43

† Denotes C.C.N.O.

Subject

T

Tablecloths and Mats	5/44
Table Linen and Table Napkins - Allowances of	317/43
Tables - Operating	278/43
Tails Propelling Rocket U.2" Mark II - Not to be used	42/44
Tapes for measuring Oil Fuel	270/43
Taps, Stocks and Dies - Adoption of Commercial Type for use in H.M.A. Ships and Establishments	367/43
Target Practice Mark I*, Rockets, Lot S.129 and 144 - Withdrawal - Reports	324/44
Rockets 1 lb.	452/43
Targets - Anti-Craft - Kites and Drogues for - Discontinuance of Supply	146/44
Technical Colleges, Melbourne and Sydney - Correspondence Courses at Information - Promulgation to personnel	146/43
Information - Promulgation to personnel	3/43
Telegrams - Christmas and New Year Greetings	604/43
Telegraphist Ratings - Eligibility for Exemption Subjects of the Examinations for P.M.G. and Certificates	75/44
Telephone Trunk Line Calls by Naval Personnel	492/43
Teleprinter Operators	439/43;60,272/44
Telescopes, Bore, for Q.F.4" Mark XIX Guns	269/43
Temporary Commissions - Coder Ratings	582/43
- Selection of Ratings from the Lower Deck	103,412/43
Warrant Rank - Promotion to	119/44
Tenders - Submissions to Naval Board by	94/43
Terne Iron - Use of - Service Buildings	651/43
Test of Recoil Cylinder Liquid - Gun Mountings	192/44
Testimonials and Memorial Prizes	25/44
Testing Equipment, A/S - Fairmiles and H.D.M.L's	†74/43
- W/T - R/T Set - Modification	†80/44
Tests - Routine - Depth Charge Pistols	421/43
Tetanus - Prophylaxis	87/44
Text Books - Vocational Training	287/44
The Legacy Club	625/43
Thompson Sub-Machine Guns 0.45-in. - Tool Recoil Spring - Instructions for use	†44/43
Thrower Pistols - Depth Charge - Spares	65/44
Throwers - Depth Charge Mark II - Replacement of	†25/44
Tickets - Exchange of Railway Warrants for	342/43
Time Fuzes No.401 Marks I and IA	153/44
on Board H.M.A. Ships - Annual Percentage landing in War Time	253/44
Mechanical Fuzes returned from Ships - Amendment of C.B. 3063 (N.M.E.R.)	†144/43
Tyres and Tubes - Conservation of	279/43
T.N.T. Charges for Harbour Defence - 5 lb.	†43/43
- Use of Blocks, T.N.T.8 oz. Signal Mark I	†169/43
Tool Loading Magazine: Introduction - Oerlikon Machine Guns 20 mm.	125/43
Tools - Compensation for loss of	184/44
- Confidential Outfits of - R.M.S. and B.S. Organization	27/43
- Pioneers', for Landing Parties	558/43
- Preservation of	125/43
Torches and Sleeves for Inflatable Lifebelts - Life Saving Equipment	212/44
Torpedo - Acoustic Homing - Counter Measures to - F.X.R. Gear Depot, Fremantle	†120/44
Igniters, Mark XI - Lot 144, Filled SWYN 9/41 - Withdrawal	65/44
Withdrawal	64/44

† Denotes C.C.N.O.

Subject

C.N.O. or
C.C.N.O. No.

T - contd.

Torpedo - Igniters, Mark XI - contd.	
- Lot No. 217, Filled B.R.12/41 - withdrawal	155/44
Non-substantive Rates - Recommendations for Stores, Gunmounting and Naval Armament - Despatch of, to Melbourne	97/43
Torres Strait Pilots - use by Fleet Attendant Oilers	420/43
Total Loss of Uniform and Clothing - Compensation for - Ratings	170/43
Towels, Blankets and Duffel Coats for Survivors for Survivors	147/44
- Supply of, in Victorian State Hostels	300/45
Towing, Hawser - A.M.S. Vessels	349/45
Traders' Account for Supplies to H.M.A. Ships Payment of	465/43
Training - Chemical Warfare	401/43
of Engine Room Ratings	534/43
Personnel - Acting Installations Types 144/3	361/43
Young Seamen Ratings in H.M.A. Ships	4/45
- Vocational during the War - Correspondence Courses	70/44
Transfer of R.A.N.R. Ratings to the Permanent Naval Forces (Seagoing)	48/45
Invalids - Use of Army Facilities in	340/43
Transfers from one branch to another	498/43
Transmission of Confidential Messages in plain language over Teleprinter Channels	259/44
Transponder - Radar - Type 253 - Instructions for Fitting at R.A.N. Bases	251/43
Transport of Coding Machines and Spare Parts	198/43; 1133/44
Transportation - Overseas Air	1107/44
- Service Personnel Travelling in Uniform	124/44
Travel Concessions in New South Wales for Members of the Forces - Interstate, Rail - Wives and Families of Naval Personnel	84/45
Travelling Expense and Route Order Claim - Form A.S.542	37/44
Treatment in Approved Private Hospitals - Rates of	50/45
of ex-members of the Forces suffering from malaria which did not manifest itself during the member's service	524/45
Undeliverable Postal Articles	435/45
Trials - Gun - Procedure	305/44
Tropical Clothing	175/44
- Khaki - Additional Supply to Ratings Serving in Northern Areas	351/45
- R.A.N. Auxiliary Service Ratings	38/44
Dress - Medal Ribbons	171/45
Outfit Gratuity - Sydney	170/45
- Grant for	461/45
Scientific Section	512/44
Trousers - White Duck	297,476/45
Tubes and Tyres, Conservation of	77/45
Vent, Electric 1-in. I.C.I. Manufacture	271/44
Tunics, Drill, with Blue Facings - Shedding of Dye	271/44
Twelve Pdr. Gun Mountings	514/45
Twenty M.M. Oerlikon Guns - Care and Maintenance	279/45
Training Safety Rail	1153/44
Twin Mountings - Marks to be used for Guns in - Fuzes Percussion D.A. No.250	665/43; 71/44
Type AT5/AT8 W/T - R/T Set - Modification	183/45
A272 Mk.I Radar - Obsolescence of Aerial, Transmitter - Modulator and Aerial Control Units	220/45
	7/45
	165/45
	180/44
	187/44
	† Denotes C.C.N.O.

Subject

C.N.O. or
C.C.N.O. No.

T - contd.

Type - contd.

- 253 - Radar Transponder, Instructions for Fitting at R.A.N. Bases	1107/44
Typewriter Ribbons and Carbon Paper	427/43

U

Unclaimed Effects of Personnel	216/43
Undeliverable Postal Articles - Disposal	351/43
Unfitness, Physical, for Service - Discharge from R.A.N. on account of	93/45
Uniform(s) and Clothing - Authorized Kits - R.A.N. Women's Services	375,424,612,635,645,646,662,675,683/43;
	55/44
- W.R.A.N.S.	20,128/44
- Compensation for Total Loss of - Ratings	147/44
- Issue of, on repayment to personnel of Allied Navies	369/43
- Ratings - Compensation for Loss or Damage to	204/43
- Supplies	189,464/43
- Repayment Issues of Materials	674/43
Grant - Special - to Officers Travelling with a Minimum of Baggage	159/43
- Lacing worn by Lieutenant Commanders R.A.N.V.R.	127,259/43
- Officers' - Agreement for the supply of - Inclusion of Uniforms for Nurses and W.R.A.N.S. Officers	222,350/43
- Held for Disposal at Royal Edward Victualling Yard, Sydney	509/43
- Supply of	169,253/43
- Outfit Gratuities on change of class of	548/43; 150/44
- Provision of Service - Unmobilized Medical Officers	203/43
- Ratings' - Made-to-Measure - Contracts for Supply of, by Private Outfitters - at Adelaide	257/43
	Hobart
	115/43
	Melbourne and Sydney
	39,114/43
	Perth
	116/43
- Summer - Naval Dockyard Police	462/43
	- Issue of Chevrons
	190/43
Unmobilized Medical Officers - Provision of Service Uniform	203/43
Unserviceable American Ammunition - Disposal of	178/44
Condemned etc. Stores - Salvage of - Army Salvage Service	267/44
Flags and Inglefield Clips - Return to Store	69/44
Upper Deck Fittings - H.M.A. Ships - Maintenance of	178/44
Use of Army Medical Facilities in Transfer of Invalids	259/44
Form F.A.50 - Naval Armament Store Accounts in Small Craft Gas by Enemy - Responsibility for Identification and Procedure for Reporting	295/43
Reduced Charges for Practice Q.F. 4" Marks XVI - XVI* Guns	124/43
	180/43

† Denotes C.C.N.O.

Subject

C.N.O. or
C.C.N.O.No.

U - contd.

Use of - contd.

Union Jack or Australian Flag at Funerals of Members of the Australian Services	568/45
U.S.N. - R.A.N. arrangements for supply of common and other Naval Stores	†105/45
Utensils, Mess for C.P.O's., P.O's. and Mens' Messes - Replacement Allowances for 1942-43	152/45
V	
Vacancy for Librarian (Female) Secretariat, Department of Defence, Melbourne	628/45
Vaccination and Re-vaccination	308/45
Valedictory - Vice Admiral A.S. Carpenter, U.S.N.	24/44
Valve - Improved Type N.T.A.98 for Radar Type A272 Mark I	†34/44
Valves - Shuttle - Reciprocating Pumps - Heat Treatment	107/44
Variations in Kit - Small Blue Kit-Bags and Suit Cases	254/44
Vegetables - Dehydrated	173,457/45
Vehicles - Naval Motor - Accidents	56/44
Venereal Disease - Control of - Prophylactic Centres	†152/44
- Melbourne Area	40/44
Venner Time Switch L.L.Minesweepers	87/45
Ventilating Fan - Loss of	66/44
Ventilation of Naval Stores - A.M.S. Vessels	†51/45
Wardroom Pantries - A.M.S. Vessels	†89/44
Vessels - A.M.S. - see A.M.S. Vessels.	
- Auxiliary - Naval Store Accounts	499/45
V.H/F. R/T Set - Fitting of - Alteration and addition	†125/45
- A.M.S. Vessels	†117/45
Vibration of Steam-driven Boiler Room Fan Engine - A.M.S.Vessels	†123/44
Vickers Machine Guns .303" - Loss in transit	78/45
On Single A.A.Mountings - Butts for	39/44
Victorian Railways - Concession Fares on Suburban Lines and to and from certain country towns - N.A.P.	14/45
Victory Loan	117/44
Victualling Stores Consignments of	256/45
- Supply of, for A.M.S. Vessels, Frigates Fairmiles and H.D.M.Ls. on Commissioning	673/45
Yards - Condition of Stores and Equipment returned to	167/45
- Return of Stores to	188/45
Victuals in Provision Account with Ship's Ledger - Reconciliation of Numbers claimed for	283/45
Vision - Standards of - Radar personnel	†92/45
Visual Signallers, Coders, T/P and Automatic Morse Operators - W.R.A.N.S. - Advancement	204/44
Vocational Training during the War - Correspondence Courses	340/45
- Text Books	287/44
Voice Pipe Communication - A.M.S. Vessels - Alteration and Additions	†103/44
Voltage Regulation in Auxiliary Minesweeping Vessels fitted with D.G. and S.A. Equipment	†14/45
V/S and W/T Ratings - Training and Advancement during the war	325/45
V/S 1 and W/T 1 - Granting of Acting Non-Substantive Rates	259/45

† Denotes C.C.N.O.

Subject

C.N.O. or
C.C.N.O.No.

W

War Comforts	525/45
Service - Apprentices	291/44
- Chevrons for	219/44
Warrant Electrician - R.A.N. Professional Examination for the rank of	570,602/45
Mechanicians - Professional Examination	286/45
Officers appointed in lieu of those who have passed Advanced Gunnery Course - Non-Specialist Allowance	214/45
Rank - Temporary - Promotion to	119/44
Allowance	214/45
Writers and Warrant Supply Officers - Professional Examination	304/45
- Promotion to - Conditions	289/44
Warranted Provisions	128/45
Warrants for Arrest of Deserters and Absentees	451/45
- Leave Travelling Concession - Issue of	275/45
- Railway - Exchange of, for Tickets	342/45
Warranty Period for Canned Meats	562/45
Provisions	68,255/44
Wartime - Advancement of Mechanicians in	448/45
Washers - India Rubber, for Hose Couplings - use of Correct Patterns	144/45
Watchkeeping Certificate - R.A.N.R. Officers	256,319/44
Water Bottles - Emergency Water Ration for personnel at Sea - Supply of	136/44
Pressure Test - Gas Cylinders	289/45, 295/44
Supply, Ships' at Port Moresby	363/45
Waterproof Coats - Belts	298/45
- Officers and Ratings	591/45
Watertight Percussion Detonators - Mark VII Lot 141 B.R.8/41 - Withdrawal from service	41/44
Wattle Rod Fenders	280/44
Weapon Maintenance - Admiralty Fleet Orders 1024 and 1025/43	606/45
Weapons - New - Action to be taken on receipt of	618/45
Wearing of Shoulder Straps - Royal Australian Naval Nursing Service	175/44
Web Equipment - Pattern 1957	157/44
Weekly Report of stock by Shore Establishments	326/44
Stock Reports - Depth Charges and Associated Stores	†46/45; †72, †155/44
Welfare Committees	247/45
White Duck Trousers	514/45
Wife "De Facto" - Change of Term	490/45
Wills - Compulsory making of	47/45, 220/44
Wireless Stations Control Order - Revocation of direction under	80/44
Wiremen - Ratings - Advancement	156/45
Wives and Fianceses - Passports for - Service personnel overseas	157/44
Women's Royal Australian Naval Services - Convalescent Home for - Statutory Rules	284/44
- Uniform and Clothing	10/44
- Author- ized Kit	424,612,655,645, 646,662,675/45
Wood and Steel Blocks	683/45; 20,55, 105,128/44
Wooden Furniture - Replacement by Steel, in Cruisers, Destroyers, A.M.S. Vessels, and "Warrego", "Swan" and "Moresby"	512/45
	505/45

† Denotes C.C.N.O.

Subject

C.N.O. or
C.C.N.O.No.

W - oontd.

W.R.A.N.S. - Bedding for	169/44
- Drafting	159/44
- Galley Shoes for Cooks	77/44
- Gymnastic Shoes for	19/44
- Members of - Discharged on Account of Pregnancy	†116/44
- Mess Gear - Amendments to Scales	205/43
Officers and Nurses - Agreement for Supply of	
Uniforms for	222,330/43
Ratings - Badges for	95/43
Regulations and Instructions	30/43
- Uniform and Clothing	375,612,633,645,646, 662,675/43;20,55,103, 128/44
- Visual Signallers, Coders, T/P and Automatic	
Morse Operators - Advancement	204/44
- W/T Ratings - Advancement	470/43;273/44
Wreaths - Purchase of	564/43
Writer Junior and Supply Ratings - Typewriting experience ..	172/44
W/T and V/S Ratings - Training and Advancement during the war	323/43
A/S, Radar etc. Equipment - Establishment List	511/44
Equipment of Australian Manufacture - Replacement Parts ..	473/43
Ratings W.R.A.N.S. - Advancement	470/43;273/44
- R/T Set - Type AT5/AR8 - Modification	†128,†176/43
- R/T Transceiver Installation, Type R.C.8 - Supply of Low	
Power	†50,†35/43
Testing Equipment for Frigates	194/44
Transmitters fitted for Crystal Control - A.W.A. Type ..	†104/43
1 and V/S 1 - Granting of Acting Non-Substantive Rates ..	239/43

X

X-ray Burns - Prevention	456/43
Examinations - Microphotographic	329/44

† Denotes C.C.N.O.

LIST OF NAVY ORDERS ISSUED BETWEEN 1st JANUARY, 1939, AND
30th JUNE, 1944, WHICH HAVE BEEN CANCELLED.

Cancelled Order	Superseded by	Cancelled Order	Superseded by
1939		1941 - contd.	
39	30/40	155	366/41
50	420/43	157	234/42
85	107/39	164	380/43
96	420/43	185	334/42
156	37/40	206	136/43
139	91/40	216	351/43
		228	103/43
		228	103/43
		261	334/42
1940		263	212/42
2	249/40	519	342/42
34	332/42	326	429/43
37	132/41	340	410/42
41	58/41	368	410/42
89	342/42		
90	155/40		
91	23/41	1942	
104	282/42	2	103/43
120	39/41	18	256/44
146	285/40	28	429/43
150	393/42	38	448/42
167	61/44	60	230/42
188	250/40	75	446/43
213	578/43	82	230/42
216	504/42	86	230/42
228	489/43	89	446/43
232	328/43	104	339/43
240	304/42	107	230/42
250	73/42	119	263/44
257	498/43	133	342/42
275	359/43	147	518/43
301	315/41	158	446/43
		160	332/42
		170	332/43
		177	448/42
1941		183	519/43
4	64/41	184	414/43
9	362/43	219	134/43
10	513/43	230 - Part 2(b)(iii)	375/42
22	601/43	- Part 2(q)	210/43
23	232/43	239	339/43
42	355/41	248	263/43
54	232/41	230	480/43
103	412/42	282	149/43
113	601/43	283	146/44
127	351/41	288	339/43
129	355/41	292	263/43
133	136/43	293	448/42
134	23/44	299	471/43
135	393/42	303	149/43
148	103/43	304	601/43
154	239/41	321	525/43

Cancelled Order	Superseded by	Cancelled Order	Superseded by
<u>1942 - contd.</u>		<u>1945 - contd.</u>	
352	480/45	†151	†36/44
358	446/45	†142	†45/44
360	256/44	145	359/45
361	525/45	†160	†141/44
375(b)	210/45	†174	†141/44
389	265/45	†175	†36/44
394	197/45	†176	†80/44
398	519/45	†179	†71/44
455	390/45	226	158/44
440	351/45	245	265/44
446	265/45	246	446/45
449	102/45	265	266/44
453	525/45	284	127/44
461	480/45	331	241/44
		360	257/44
<u>1945</u>		392	266/44
25	456/45	446	25/44
†25	†20/44	521	265/44
†29	†57/45	576	265/44
†34	†56/44	594	265/44
†36	†85/44		
40	519/45	<u>1944</u>	
41	229/44	†2	†117/44
†46	†72/44	†10	†159/44
46	127/44	†15	†36/44
†61	†117/44	†14	†71/44
†64	†158/45	†15	†80/44
†83	†151/45	†35	†141/44
†86	†118/45	†36	†72/44
†94	†125/45	†47	†72/44
118	480/45	†64	†140/44
†128	†80/44	†71	278/44
†150	†85/44	76	

† Denotes C.C.N.O.

RESTRICTED.

(FOR OFFICIAL USE ONLY.)

Commonwealth Navy Orders.

Navy Office, Melbourne,
4th January, 1944.

The following Orders, having been approved, are hereby promulgated for information and guidance, and necessary action.

By direction of the Naval Board,

J. P. Macandee

Secretary.

*The Rear-Admiral Commanding H.M.A. Squadron,
and Commanding Officers of H.M.A. Ships,
Officers in Charge of H.M.A. Naval
Establishments, and others concerned.*

TABLE OF CONTENTS.

No.	Subject.
1.	Issue of Navy Orders.
2.	Boxes Ammunition C.222 and C.199.
3.	P.A.C. Rocket Failures.
4.	Ball and Roller Bearings Procurement.
5.	Table Cloths and Mats.
6.	Flags on Commonwealth Buildings.
7.	Badges—Controlled and Observation Mining Ratings.
8.	Photographic Material for Use in H.M.A. Ships and Establishments.
9.	Form A.S. 539Z "Long Leave Book."

1.

ISSUE OF NAVY ORDERS.

The last Navy Order issued for 1943 was No. 685.

2.

BOXES AMMUNITION C.222 AND C.199.

It has been decided that, as far as possible, Q.F. 4-in. XVI* gun ammunition packed in boxes C.222 (steel box to hold 2 rounds) will be reserved for ammunitioning ships *ex* main armament depots only, and boxes ammunition C.199 (wood, tin-lined box to hold 4 rounds) utilized for the despatch of ammunition to other bases, A.S.I. Ships and forward areas.

2. This action is necessary because of the superior weather-proof qualities of Box C.199.

3. All empty boxes C.222 and C.199 surplus to requirements are to be returned to the nearest naval armament depot as early as practicable.

(421/202/756.)

3.

P.A.C. ROCKET FAILURES.

Cases have occurred where the wire of P.A.C. apparatus has parted near the rocket and investigation has shown that this may have been due to displacement of the asbestos sleeve on the rocket tail.

2. The asbestos sleeve on the tails of P.A.C. rockets is meant to protect the wire from the flame of the rocket. It is found that, if the wire is directly exposed to the flame, it may be so weakened that it sometimes breaks under the stress of lifting the lower parachute, and it will certainly not stand up to the impact of a colliding aircraft.

3. As at present fitted, the top end of the asbestos sleeve is secured by asbestos twine. This lashing may get loose or broken by rough handling so that the sleeve can slip down when the blast of the rocket impinges on it, thus exposing the top end of the wire tail to the flame.

4. A warning should be issued to all users that, when shipping a P.A.C. rocket for use, the lashing on the top end of the asbestos sleeve is to be inspected. If there is any doubt about the firmness of this asbestos twine lashing, it is to be reinforced by two turns of copper wire, gauge 20.

(471/208/872.)

4.

BALL AND ROLLER BEARINGS PROCUREMENT.

The procurement of ball and roller bearings from overseas has become progressively more difficult, and unless each order is supported by complete information as to necessity, end use, &c., there is little prospect of supply being obtained.

2. In future, all demands for ball and roller bearings are to be accompanied by the necessary data to enable the information indicated in the subjoined schedule to be furnished to the Ministry of Munitions when supply is ordered:—

SCHEDULE.

1. Maker's name.
2. Type No. or full description if of special type.

3. Production rate of unit for which required and date of commencement of manufacture.

4. Description and number of machines or units for which required.

5. Number of bearings in machine or unit.

6. Position in machine or unit (location).

7. Whether new machine or unit or replacement of spares.

8. Full particulars of end use.

(532/201/1133.)

5.

TABLE CLOTHS AND MATS.

The allowances of table cloths promulgated in Navy Order 317 of 1943 are superseded by the following allowances, which are to operate forthwith:—

Flag and Commanding Officers' Messes.

(a) 4 No. cloths per table, or

(b) 2 No. cloths per table, plus up to 24 No. cotton mats and 12 No. lino mats as required.

Other Officers' Messes.

(a) 3 No. cloths per table, or

(b) 1 No. cloth per table, plus 2 No. cotton mats and 1 No. lino mat for each officer. In addition, 25 per cent of the total number of cotton mats and 10 per cent. of the total number of lino mats as spares, subject to a minimum allowance for spares of 4 No. cotton mats and 2 No. lino mats per table.

2. The cotton mats measure 13 in. by 9 in., while the lino mats, which are made of heat-resisting material, measure 7 inches in diameter.

3. All cloths, at present held in excess of the revised allowances at (a) in paragraph 1 above, are to be withdrawn from use, and are to be returned to the nearest H.M.A. Victualling Yard unless they will be required within a reasonable time as replacements to maintain the authorized allowances of cloths. In demanding replacements from Victualling Yards, cloths or mats may be demanded as preferred.

4. Demands for new Ships and Establishments commissioning should indicate the numbers and sizes of tables, and the numbers of cloths and mats, if any required.

5. The arrangements under which table mats may be purchased, as set out in B.R. 93, Manual of Victualling, Volume 1, Chapter XIII, Section A, paragraph 26, are suspended for the period of the war.

(530/201/502.)

6.

FLAGS ON COMMONWEALTH BUILDINGS.

With reference to C.O.R., Article 67, when directions are issued on special occasions that flags are to be displayed on Commonwealth buildings, such directions will apply only to those civilian establishments which normally fly the Commonwealth Flag, and not to other Naval Establishments which wear the White Ensign.

(476/201/722.)

7.

BADGES—CONTROLLED AND OBSERVATION MINING RATINGS.

The following are the repayment issuing prices for badges for controlled and observation mining ratings, *vide* Navy Order 96 of 1943:—

- Pattern 126A, Leading Watchkeepers C.M. and Watchkeeper C.M., red, each 7d.
- Pattern 126B, Leading Watchkeepers C.M. and Watchkeeper C.M., blue, each 6½d.
- Pattern 131A, Letters C.M., red, each 4d.
- Pattern 131B, Letters C.M., blue, each 4d.
- Pattern 132A, Letters C.M.S., red, each 5d.
- Pattern 132B, Letters C.M.S., blue, each 5d.

2. The necessary additions are to be made to the "Official Memorandum—Prices of Clothing, &c., Maintained for Issue on Repayment to Ships' Companies" dated 1st May, 1943, details as above, under the heading "Controlled and Observation Mining Ratings," being inserted on page 13 after the item "badges pattern 134b."

(416/201/915.)

8.

PHOTOGRAPHIC MATERIAL FOR USE IN H.M.A. SHIPS AND ESTABLISHMENTS.

Consideration has been given to the question of procurement of photographic material to permit the taking of photographs of interest for official records by personnel in H.M.A. Ships and Establishments in possession of private cameras.

2. Approval is given for the Commanding Officers of H.M.A. Ships other than M.Ls., also the Naval Officers-in-Charge at the following ports to purchase direct on official orders small quantities of photographic material for issue to the rating in each ship, &c., selected as the ship's photographer for the purpose indicated in paragraph 1:—

Cairns.	Port Moresby.
Townsville.	Milne Bay.
Thursday Island.	Oro Bay.
Darwin.	

3. Purchases of photographic material should be confined to those necessary for the purpose referred to in this Order and are not, in the case of any ship, to exceed £2 per quarter.

(560/201/948.)

9.

FORM A.S. 539Z "LONG LEAVE BOOK."

In view of the need of economy, Form A.S. 539Z "Long Leave Book" will not be reprinted during the period of hostilities. A suitable manuscript record is to be kept in lieu.

(480/202/4494.)

By Authority: H. E. DAW, Government Printer, Melbourne.

RESTRICTED.

10-22

(FOR OFFICIAL USE ONLY.)**Commonwealth Navy Orders.**

Navy Office, Melbourne,

11th January, 1944.

The following Orders, having been approved, are hereby promulgated for information and guidance, and necessary action.

By direction of the Naval Board,

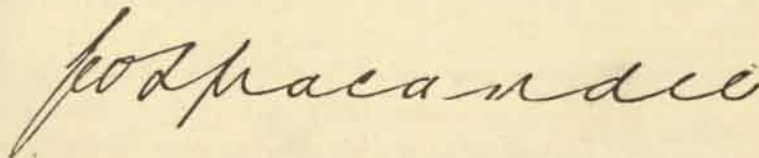

Secretary.

*The Rear-Admiral Commanding H.M.A. Squadron,
and Commanding Officers of H.M.A. Ships,
Officers in Charge of H.M.A. Naval
Establishments, and others concerned.*

TABLE OF CONTENTS.

No.	Subject.
10.	Women's Services—R.A.N.—Statutory Rules Governing the Administration of.
11.	A.M.S. Vessels—Deterioration of C.I. Condenser Doors.
12.	Motor Launches—Type "B" Fairmiles.
13.	Examination of Engine Room Ratings—September, 1943—Results.
14.	Rehabilitation Procedure for Discharged Personnel.
15.	Malaria—Measures for Prevention and Control—Supply of Stores.
16.	Coding Branch.
17.	Supply Rating (A.S.)—New Rating.
18.	Losses of Pistols, Revolver.
19.	Uniform and Clothing for Wrens—Gymnastic Shoes.
20.	Women's Royal Australian Naval Service—Uniform Clothing—Authorized Kit.
21.	Oilskin Anti-gas Clothing—Upkeep and Repair.
22.	Office Machinery Annual Census.

**WOMEN'S SERVICES—R.A.N.—STATUTORY RULES GOVERNING
THE ADMINISTRATION OF.**

The following Statutory Rules, providing for the administration of the Women's Services of the Royal Australian Navy, are promulgated for information.

(a) STATUTORY RULES 1943, No. 66.

REGULATIONS UNDER THE NATIONAL SECURITY ACT 1939-1940.*

I, the Governor-General in and over the Commonwealth of Australia, acting with the advice of the Federal Executive Council, hereby make the following Regulations under the *National Security Act 1939-1940*.

Dated this twenty-third day of March, 1943.

GOWRIE,
Governor-General.

By His Excellency's Command,

JOHN CURTIN,
Minister of State for Defence.

**NATIONAL SECURITY (WOMEN'S SERVICES)
REGULATIONS.**

1. These Regulations may be cited as the National Security (Women's Services) Regulations.

2. These Regulations shall be administered by the Minister of State for Defence.

3. (1) In these Regulations, "Women's Service" means any Women's Service constituted under the Naval Forces (Women's Services) Regulations, the Military Forces (Women's Services) Regulations or the Air Force (Women's Services) Regulations.

(2) Unless the contrary intention appears, words used in these Regulations shall have the same meaning as in the *Defence Act 1903-1941*.

4. Notwithstanding anything contained in the *Defence Act 1903-1941*, the *Naval Defence Act 1910-1934*, the *Air Force Act 1923-1941*, any regulation made under any of those Acts, or any Imperial Act, rule or regulation which by any of those Acts or regulations made thereunder is applied to the Defence Force or any part or members thereof, a member of a Women's Service shall not—

(a) have a right to elect to be tried or be liable to trial by court-martial for any offence; or

(b) be eligible to sit or otherwise act as a member of a court-martial.

5. (1) A member of a Women's Service which forms part of the Naval Forces shall not do any act or be guilty of any conduct which, by sections 3 to 16 (both inclusive), 19, 20, 21, 25, 26, 29, 33, 34 and 35 of the Imperial Act called the Naval Discipline Act, is prescribed to be an offence or to be punishable under that Act.

* Notified in the *Commonwealth Gazette* on 24th March, 1943.

(2) A member of a Women's Service which forms part of the Military Forces or the Air Force shall not do any act or be guilty of any conduct which, by sections 4, 5, 6, 7, 12, 14, 17, 23, 24, 25, 35 and 36 of the Army Act or the Air Force Act, as the case may be, is prescribed to be an offence or to be punishable under that Act.

6. A member of a Women's Service who has been acquitted or convicted of a breach of these Regulations or any other offence against the *National Security Act 1939-1940* shall not be punished summarily under the *Defence Act 1903-1941*, the *Naval Defence Act 1910-1934*, the *Air Force Act 1923-1941*, or any regulations made under any of those Acts, for the same offence:

Prohibition of dual punishment for the same offence.

Provided that nothing in this regulation shall prevent the dismissal or discharge from the Defence Force of any member convicted of any such offence.

7. Notwithstanding anything contained in the *Naval Defence Act 1910-1934*, a member of a Women's Service which forms part of the Naval Forces who is appointed or enlisted for service within the limits of Australia only shall not be required to serve beyond those limits unless she voluntarily agrees so to serve.

Limits of service of members of the Naval Forces.

(b) STATUTORY RULES 1943, No. 67.

REGULATIONS UNDER THE NAVAL DEFENCE ACT 1910-1934.*

I, the Governor-General in and over the Commonwealth of Australia, acting with the advice of the Federal Executive Council, hereby make the following Regulations under the *Naval Defence Act 1910-1934*.

Dated this twenty-third day of March, 1943.

GOWRIE,
Governor-General.

By His Excellency Command,

NORMAN J. O. MAKIN,
Minister of State for the Navy.

NAVAL FORCES (WOMEN'S SERVICES) REGULATIONS.

PART I.—INTRODUCTORY.

1. (1) These Regulations may be cited as the Naval Forces (Women's Services) Regulations.

Citation and Administration.

(2) These Regulations shall be administered by the Minister of State for the Navy.

2. These Regulations are divided into Parts, as follows:—

Parts.

Part I.—Introductory.

Part II.—Royal Australian Naval Nursing Service.

Part III.—Women's Royal Australian Naval Service.

Part IV.—Discipline.

Part V.—General.

* Notified in the *Commonwealth Gazette* on 24th March, 1943.

Definitions.

3. In these Regulations, unless the contrary intention appears—

“Director of Naval Medical Services” means the officer appointed by the Naval Board to administer the Medical Services of the Royal Australian Navy;

“member” means a woman appointed to or enlisted in a Women’s Service under these Regulations;

“officer” means any member other than an enlisted member;

“rating” means an enlisted member;

“Women’s Service” means one of the Services specified in Regulation 4 of these Regulations.

Establishment
of Women’s
Services

4. There shall be the following Services, composed of women, appointed or enlisted in accordance with these Regulations, which shall form part of the Naval Forces:—

The Royal Australian Naval Nursing Service.

The Women’s Royal Australian Naval Service.

PART II.—ROYAL AUSTRALIAN NAVAL NURSING SERVICE.

Constitution.

5. The Royal Australian Naval Nursing Service shall consist of officers appointed to that Service for the performance of such duties in connexion with nursing of members of the Naval Forces as the Naval Board determines.

Appointments.

6. The Minister may, on the recommendation of the Naval Board, recommend to the Governor-General suitable candidates for appointment as officers of the Royal Australian Naval Nursing Service.

Reserve List.

(Inserted
S.R. 1943/201)

6A. An officer, appointed to the Royal Australian Naval Nursing Service and awaiting allotment to duty, may be placed on a Reserve List, and whilst on the Reserve List shall not be entitled to any pay or allowances.

Eligibility.

7. A woman may be appointed an officer of the Royal Australian Naval Nursing Service, if she—

(a) is not less than twenty-one or more than forty-five years of age;

(b) is a nurse registered as such under the provisions of any law of the Commonwealth, or of any State or Territory of the Commonwealth; and

(c) has had not less than three years’ service and training in medical and surgical nursing in a hospital approved by the Director of Naval Medical Services;

(d) has passed such medical examination as is approved by the Naval Board.

Provided that a woman who is more than forty-five years of age may be appointed as a Matron or Superintending Sister, if the Naval Board certifies that she has special qualifications or that it considers that special circumstances warrant her appointment.

8. The grades of officers of the Royal Australian Naval Nursing Service shall be those set out in the first column of the following table and, for the purpose of determining relative rank, they shall correspond with the ranks of male officers of the Naval Forces specified opposite thereto respectively in the second column of the table:—

Matron	Lieutenant-Commander.
Superintending Sister	Lieutenant.
Sister (Grade I.) or Staff Masseuse (Grade I.)	}		Sub-Lieutenant.
Sister (Grade II.) or Staff Masseuse (Grade II.)			

9. (1) An officer of the Royal Australian Naval Nursing Service may be promoted to a higher grade if she is selected for promotion thereto by the Naval Board upon a recommendation by the Director of Naval Medical Services.

(2) Subject to sub-regulation (1) of this Regulation—

(a) a Sister (Grade II.) or Staff Masseuse (Grade II.) may be graded as Sister (Grade I.) or Staff Masseuse (Grade I.), as the case may be, upon her completion of twelve months’ continuous and satisfactory service.

(b) an officer may be graded as Superintending Sister or Matron if a vacancy in the grade exists in the authorized establishment.

10. In a Naval hospital and in its vicinity, a member of the Royal Australian Naval Nursing Service shall, in matters of medical service, have authority next after officers of the Medical Branch of the Royal Australian Navy and shall at all times be obeyed accordingly.

11. Members of the Royal Australian Naval Nursing Service shall be under the command of the Commanding Officer of the Establishment to which they are attached, but the control of the nursing staff shall be the responsibility of the Matron, or, if there is no Matron in charge for the time being, the Superintending Sister.

PART III.—WOMEN’S ROYAL AUSTRALIAN NAVAL SERVICE.

12. The Women’s Royal Australian Naval Service shall consist of female officers and ratings appointed to, or enlisted in, that Service for the performance of such duties in relation to the Naval Forces as the Naval Board determines.

13. The Minister may, on the recommendation of the Naval Board, recommend to the Governor-General suitable candidates for appointment as officers of the Women’s Royal Australian Naval Service.

14. A woman shall be eligible for appointment to, or enlistment in, the Women’s Royal Australian Naval Service, if she has—

(a) attained the age of eighteen years, but has not attained the age of forty years; and

(b) passed such medical examination as is approved by the Naval Board:

Provided that a woman who has attained the age of forty years, but has not attained the age of fifty years, may be appointed to, or enlisted in, the Women's Royal Australian Naval Service, if the Naval Board certifies that she has special qualifications or that it considers that special circumstances warrant her appointment or enlistment.

15. Ratings of the Women's Royal Australian Naval Service shall be enlisted for the period of the duration of the war and six months thereafter or two years, whichever period is the greater.

16. The ranks of officers in the Women's Royal Australian Naval Service shall be those set out in the first column of the following table, and, for the purpose of determining relative rank, they shall correspond with the ranks of male officers of the Naval Forces specified opposite thereto in the second column of that table:—

Chief Officer	Commander.
First Officer	Lieutenant-Commander.
Second Officer	Lieutenant.
Third Officer	Sub-Lieutenant.
Third Officer (on probation)	Acting Sub-Lieutenant.

17. The ratings of women enlisted in the Women's Royal Australian Naval Service shall be those set out in the first column of the following table, and, for the purpose of determining relative rating, they shall correspond with the ratings of men of the Naval Forces specified opposite thereto in the second column of that table:—

Wran	Able Seaman.
Leading Wran	Leading Seaman.
Petty Officer Wran	Petty Officer.
Chief Petty Officer Wran	Chief Petty Officer.

18. Women may be entered with such rating as the Naval Board, having regard to the qualifications of the candidates and the vacancies in the authorized establishment, approves.

19. (1) An officer may be promoted to a higher grade, if she is recommended for promotion by the Naval Board and a vacancy in that grade exists in the authorized establishment.

(2) The Naval Board may advance any servicewoman to a higher rating, if she is recommended for advancement by her Commanding Officer, or possesses special qualifications for advancement to that rating, and a vacancy in that rating exists in the authorized establishment.

20. The Naval Board may for any reason discharge a rating from the Women's Royal Australian Naval Service at any time.

21. An officer or rating of the Women's Royal Australian Naval Service shall not exercise command over any person other than members of the Women's Royal Australian Naval Service or members of the Naval Forces detailed or attached for duty under her command and inferior in rank or rating to herself.

PART IV.—DISCIPLINE.

22. (1) Subject to these Regulations, any officer of the Naval Forces who is authorized to deal summarily with a charge against a member of the Naval Forces of having committed any offence may, if he finds a member of a women's service guilty of an offence, award to her any one or more of the following punishments:—

- (i) disrating or reduction to the ranks;
- (ii) deprivation of good conduct badges;
- (iii) a fine not exceeding Five pounds or forfeiture of all ordinary pay for a period not exceeding fourteen days;
- (iv) extra duties for a period not exceeding fourteen days;
- (v) stoppage of leave for a period not exceeding fourteen days;
- (vi) reprimand;
- (vii) any deduction from ordinary pay which he may lawfully order to be made in respect of the offence of which the member has been found guilty,

but no other punishment.

(2) An officer authorized to deal summarily with a charge against a member of a Women's Service may, as to any member found by him to be guilty of an offence—

- (a) in addition to, or in lieu of awarding any of the punishments specified in that sub-regulation, if he considers the offence or the circumstances in which it was committed to be of such a nature as to warrant, recommend that she be dismissed or discharged; or
- (b) if he considers that she has committed an offence under the *National Security Act 1939-1940*, adjourn the case and take the necessary steps for her prosecution for that offence.

(3) Where a recommendation that a member of a Women's Service be dismissed or discharged is made in pursuance of sub-regulation (2) of this Regulation, an authority having power to dismiss or discharge the member may, in lieu of giving effect to the recommendation, in addition to any punishment already awarded her by the officer making the recommendation, award her any one or more of the other punishments specified in sub-regulation (1) of this Regulation.

23. A member under close arrest and awaiting the disposal of a charge against her shall be guarded by female guards unless female guards are unavailable.

PART V.—GENERAL.

24. Leave of absence may be granted to members for such periods and upon such conditions as the Naval Board, from time to time, directs.

25. The uniform to be worn by members shall be as approved by the Naval Board.

26. The Naval Forces Regulations for the time being in force shall, subject to such modifications and adaptations as are expressly provided or necessarily implied by these Regulations, apply to and in relation to any Women's Service and the members thereof.

Disposal of charges summarily.

Guarding of members in study

Leave of absence.

Uniform.

Application of the Naval Forces Regulations.

Period of enlistment.

Ranks of officers.

Ratings.

Rating upon entry

Promotion and advancement.

Discharge.

Command.

11.

A.M.S. VESSELS—DETERIORATION OF C.I. CONDENSER DOORS.

It has been reported that the cast iron condenser doors in an A.M.S. Vessel are showing signs of rapid deterioration. Administrative authorities are to ensure that the provisions of the Engineering Manual, Art. 80 (4), are carried out at regular intervals.

2. Where doors are removed for descaling and gauging in accordance with the above instructions, they are to be coated with "Apexior" before replacement.

(603/279/286.)

12.

MOTOR LAUNCHES—TYPE "B" FAIRMILES.

Should circumstances necessitate the slipping of Fairmile Type "B" Motor Launches on short length slips, care is to be taken to ensure that all removable heavy weights are landed from the overhanging portions of the hull before the vessel is slipped.

(603/294/796.)

13.

EXAMINATION OF ENGINE ROOM RATINGS.

SEPTEMBER, 1943.—RESULTS.

O.N.	Name.	Present Rating.	Application Received From.	Result.
E.R.A. FOR C.E.R.A.				
<i>Mechanician I. for Chief Mechanician.</i>				
23302 ..	Bennetts, C. D. W.	E.R.A., III ..	<i>Melville</i> ..	Passed Sat. 58·5 per cent.
19802 ..	Charlesworth, R. L.	Mechanician I.	<i>Australia</i> ..	Passed Sat. 64·8 per cent.
S/476 ..	Calvert, F.	E.R.A., III ..	<i>Glenelg</i> ..	Passed Supr. 71·5 per cent.
23068 ..	Dyson, A. R.	E.R.A., III ..	<i>Stawell</i> ..	Passed Sat. 67·1 per cent.
23816 ..	Knowles, F. M. ..	E.R.A., III ..	<i>Castlemaine</i> ..	Passed Supr. 70·0 per cent.
23999 ..	McDonald, A. K.	E.R.A., III ..	<i>Arunta</i> ..	Passed Supr. 70·6 per cent.
S/3329 ..	McDonnell, M. L.	E.R.A., III ..	<i>Innisfail</i> ..	Passed Supr. 76·0 per cent.
22901 ..	McGregor, L. J. ..	E.R.A., III ..	<i>Penguin</i> ..	Passed Supr. 75·3 per cent.
12266 ..	Powell, E. E.	E.R.A., II ..	<i>Penguin</i> (Hawkesbury)	Passed Supr. 79·1 per cent.
23380 ..	Rainbow, G. R.	E.R.A., III ..	<i>Australia</i> ..	Passed Supr. 81·6 per cent.
F/2907 ..	Rollinson, S. E.	E.R.A., III ..	<i>Leeuwin</i> (Medea)	Passed Sat. 68·8 per cent.
20811 ..	Robertson, C. J.	E.R.A., II ..	<i>Lithgow</i> ..	Passed Sat. 66·8 per cent.

O.N.	Name.	Present Rating.	Application Received From.	Result.
E.R.A. ACTING 4TH CLASS FOR CONFIRMATION.				
<i>Mechanician II. for Mechanician I.</i>				
F/2717 ..	Ayres, C. H.	A/E.R.A., IV.	<i>Kybra</i> ..	Passed Exceptional
20633 ..	Algie, A.	Mechn. II. ..	<i>Adelaide</i> ..	Passed Supr.
F/2544 ..	Britnell, R. D.	A/E.R.A., IV.	<i>Adelaide</i> ..	Passed Supr.
W/1221 ..	Boyce, T. E.	A/E.R.A., IV.	<i>Ararat</i> ..	Passed Supr.
S/7019 ..	Berwick, R. W.	A/E.R.A., IV.	<i>Boom Darwin</i> ..	Passed Sat.
PM/2063	Barrett, O. J.	A/E.R.A., IV.	<i>Pirie</i> ..	Passed Sat.
PA/2359	Boord, L. V.	A/E.R.A., IV.	<i>Innisfail</i> ..	Passed Supr.
F/4310 ..	Barker, J.	A/E.R.A., IV.	<i>Leeuwin</i> (Altie Cam)	Passed Supr.
PM/3899	Brattle, A. J.	A/E.R.A., IV.,	<i>Cerberus</i> ..	Passed Sat.
PM/4859	Conibear, W. K.	A/E.R.A., IV.	<i>Platypus</i> ..	Passed Sat.
PA/2861	Cameron, D. W.	A/E.R.A., IV.	<i>Allenwood</i> ..	Passed Supr.
F/4666 ..	Creighton, W. E.	A/E.R.A., IV.	<i>Kapunda</i> ..	Passed Supr.
S/6264 ..	Conway, G. T.	A/E.R.A., IV.	<i>Penguin</i> ..	Passed Sat.
S/6161 ..	Crooks, J.	A/E.R.A., IV.	<i>Melville</i> ..	Passed Supr.
F/4090 ..	Dodd, A. C.	A/E.R.A., IV.	<i>Ararat</i> ..	Passed Supr.
S/5981 ..	Dalbv, S. G.	A/E.R.A., IV.	<i>Penguin</i> (Patterson)	Passed Supr.
F/4387 ..	Duthie, W. A. ..	A/E.R.A., IV.	<i>Boom Darwin</i> ..	Passed Supr.
F/3351 ..	De Rooy, H. S.	A/E.R.A., IV.	<i>Leeuwin</i> ..	Passed Sat.
F/4684 ..	Duncan, A. B.	A/E.R.A., IV.	<i>Glenelg</i> ..	Passed Sat.
PM/4615	Ellsworth, N. R.	A/E.R.A., IV.	<i>Melville</i> ..	Passed Exceptional
PM/2540	Fountain, C.	A/E.R.A., IV.	<i>Boom Darwin</i> ..	Passed Sat.
19934 ..	Goddard, G. J.	Mechn. II. ..	<i>Hobart</i> ..	Passed Exceptional
PM/4115	Gilbert, K. McL.	A/E.R.A., IV.	<i>Westralia</i> ..	Passed Supr.
PM/2265	Gay, D. L.	A/E.R.A., IV.	<i>Leeuwin</i> (Horsham)	Passed Supr.
H/1716	Geard, R. J. I. ..	A/E.R.A., IV.	<i>Coombar</i> ..	Passed Sat.
PM/4479	Giles, R. E.	A/E.R.A., IV.	<i>Swan</i> ..	Passed Supr.
H/1795	Higgs, E. G. ..	A/E.R.A., IV.	<i>Platypus</i> ..	Passed Supr.
PM/5180	Houston, W. D.	A/E.R.A., IV.	<i>Platypus</i> ..	Passed Sat.
B/3465 ..	Hayes, B. E. ..	A/E.R.A., IV.	<i>Boom Darwin</i> ..	Passed Sat.
PM/4019	Harrison, R. F. ..	A/E.R.A., IV.	<i>Torrens</i> (Warrawee)	Passed Supr.
PA/2699	Kittell, W. E.	A/E.R.A., IV.	<i>Doomba</i> ..	Passed Sat.
PM/4255	Kingsley, A. S. J. E. K.	A/E.R.A., IV.	<i>Latrobe</i> ..	Passed Sat.
PM/1297	Legg, R. C.	A/E.R.A., IV.	<i>Hobart</i> ..	Passed Exceptional
F/4104 ..	Laing, A. C. E. ..	A/E.R.A., IV.	<i>Leeuwin</i> (Horsham)	Passed Supr.
B/3662 ..	Ludford, C. E. ..	A/E.R.A., IV.	<i>Melville</i> (Tolga)	Passed Sat.
PA/2607	Lewis, H. R.	A/E.R.A., IV.	<i>Platypus</i> ..	Passed Sat.
S/6273 ..	Lamb, D. H.	A/E.R.A., IV.	<i>Penguin</i> ..	Passed Supr.
PM/3453	McKechnie, D. A. D.	A/E.R.A., IV.	<i>Magnetic</i> ..	Passed Sat.
W/1404 ..	McLennan, R. A.	A/E.R.A., IV.	<i>Arunta</i> ..	Passed Sat.
PM/4444	McMullen, J.	A/E.R.A., IV.	<i>Bundaberg</i> ..	Passed Sat.
S/4689 ..	M. Donnell, J. J.	A/E.R.A., IV.	<i>Kybra</i> ..	Passed Sat.
PM 3205	McLean, I. M.	A/E.R.A., IV.	<i>Lithgow</i> ..	Passed Sat.
H/2155	Mathew, T. Y.	A/E.R.A., IV.	<i>Kapunda</i> ..	Passed Supr.
PM/4179	Mauger, R. D. C.	A/E.R.A., IV.	<i>Fremantle</i> ..	Passed Sat.
PM/4143	Metcalfe, A. E. ..	A/E.R.A., IV.	<i>Basilisk</i> (Wareo)	Passed Supr.
PM/2005	Moreton, L.	A/E.R.A., IV.	<i>Doomba</i> ..	Passed Supr.
H/2018	Miller, L. R.	A/E.R.A., IV.	<i>Penguin</i> ..	Passed Supr.
PM/5000	Neylon, G. L.	A/E.R.A., IV.	<i>Platypus</i> ..	Passed Sat.
PM/3930	Oakes, C. W. L. ..	A/E.R.A., IV.	<i>Moreton</i> ..	Passed Sat.
F/1109 ..	Pengilly, G. L. ..	A/E.R.A., IV.	<i>Australia</i> ..	Passed Sat.

O.N.	Name.	Present Rating.	Application Received From.	Result.
E.R.A. ACTING 4TH CLASS FOR CONFIRMATION—continued.				
<i>Mechanician II. for Mechanician I—continued.</i>				
B/3737 ..	Payne, C. G. ..	A/E.R.A., IV.	Colac ..	Passed Supr.
H/2290 ..	Richards, E. W. ..	A/E.R.A., IV.	Burrabra ..	Passed Sat.
PM/2325	Stevenson, H. R. ..	A/E.R.A., IV.	Warramunga ..	Passed Sat.
S/7262 ..	Straatman, T. C. ..	A/E.R.A., IV.	Mildura ..	Passed Sat.
PA/2773	Snoswell, F. O. ..	A/E.R.A., IV.	Melville .. (Coolebar)	Passed Supr.
H/1718 ..	Seidenburg, L. H. ..	A/E.R.A., IV.	Melville ..	Passed Exceptional
PA/2512	Shearer, R. E. ..	A/E.R.A., IV.	Boom Darwin ..	Passed Supr.
F/4091 ..	Stuart, E. G. ..	A/E.R.A., IV.	Moreton ..	Passed Supr.
F/4082 ..	Sweeting, G. G. ..	A/E.R.A., IV.	Westralia ..	Passed Supr.
S/5856 ..	Twomey, G. H. ..	A/E.R.A., IV.	Lithgow ..	Passed Sat.
PM/5485	Taafe, G. Y. ..	A/E.R.A., IV.	Torrens ..	Passed Sat.
PA/4693	Taylor, J. A. ..	A/E.R.A., IV.	Melville .. (Coolebar)	Passed Sat.
PA/3382	Tregonning, G. J. ..	A/E.R.A., IV.	Platypus ..	Passed Sat.
PM/4256	Valentine, L. P. ..	A/E.R.A., IV.	Vendetta ..	Passed Sat.
20675 ..	White, H. M. ..	Mechn. II. ..	Hobart ..	Passed Supr.
F/4156 ..	West, R. C. ..	A/E.R.A., IV.	Hobart ..	Passed Supr.
PM/2281	White, R. I. ..	A/E.R.A., IV.	Boom Darwin ..	Passed Exceptiona
<i>Stoker Petty Officer for Chief Stoker.</i>				
20537 ..	Doggett, S. G. ..	Sto. P.O. ..	Cerberus ..	Passed Supr.
19935 ..	Gunn, E. J. ..	Sto. P.O. ..	Australia ..	Passed Sat.
21524 ..	Hallard, C. ..	Sto. P.O. ..	Glenelg ..	Passed Sat.
19851 ..	Holdsworth, A. H. ..	Sto. P.O. ..	Bendigo ..	Passed Supr.
20997 ..	Michael, H. ..	Sto. P.O. ..	Inverell ..	Passed Supr.
20049 ..	Page, E. H. ..	Sto. P.O. ..	Lithgow ..	Passed Sat.
16950 ..	Smith, G. R. ..	Sto. P.O. ..	Lithgow ..	Passed Supr.
20986 ..	Upton, H. N. ..	Sto. P.O. ..	Adelaide ..	Passed Supr.
19697 ..	Williams, A. ..	Sto. P.O. ..	Australia ..	Passed Supr.
13697 ..	Wilkie, R. ..	Sto. P.O. ..	Kalgoorlie ..	Passed Supr.
20406 ..	Waller, A. H. ..	Sto. P.O. ..	Deloraine ..	Passed Supr.

2. The necessary notation should be made on Forms A.S. 1233g and 1246a.

3. Forms A.S. 442 for successful and unsuccessful candidates will be forwarded to Ships and Establishments concerned for signatures by the candidates. The original is to be retained by the candidate and the duplicate forwarded to the Naval Officer-in-Charge, Flinders Naval Depot.

(465/207/1228.)

(This Order will be reprinted for posting on Notice Boards.)

14.

REHABILITATION PROCEDURE FOR DISCHARGED PERSONNEL.

With reference to Navy Order 213 of 1943, a Special Service Section has now been established within the Directorate of Man Power which will be responsible for the rehabilitation of all discharged Servicemen. Personnel discharged from the Naval Service are to be referred to this section through Rehabilitation Officers.

2. The handbook "Rehabilitation Procedure for the Australian Defence Forces," dated 1st November, 1943, a copy of which has been distributed to all Rehabilitation Officers, sets out full details of the rehabilitation procedure.

3. Normally, the Rehabilitation Officer in the home port of the State in which a member will reside after discharge should carry out the rehabilitation procedure. This officer is to arrange with the Man Power Section in his State as to the division of responsibility for the compilation of the necessary documents and the issue of civilian ration books and identity cards. In this regard, paragraphs 15 and 17 of Navy Order 480 of 1943, are to be amended to read that application is to be made to the Rehabilitation Officers concerned.

4. In order that personnel about to be discharged may benefit fully from this organization, it is important that full details are made available to the Rehabilitation Officer concerned.

5. The procedure to be followed for those to be discharged invalided is detailed in Navy Order 336 of 1943.

6. In cases where a member is discharged from the Service for any reason, prior to proceeding to his home port, the Commanding Officer of the ship from which discharge takes place is to ensure that full details are forwarded, if possible with the member, showing reasons for discharge, issue of civilian suit (*vide* Navy Order 390 of 1943), or any other rehabilitation action taken, in addition to the certificate required by Navy Order 409 of 1942.

7. Personnel released temporarily from the R.A.N. should be referred similarly to the Rehabilitation Officer in the home port concerned. This officer will ensure that the procedure detailed in Navy Order 480 of 1943, paragraph 20, is carried out.

(350/301/32.)

15.

MALARIA—MEASURES FOR PREVENTION AND CONTROL— SUPPLY OF STORES.

With reference to Navy Order 603 of 1943, arrangements have been made with the Department of the Army for Naval requirements of stores for anti-malarial measures to be supplied from Army stocks in areas where anti-malarial measures are necessary, and at Sydney, Brisbane, Townsville and Cairns, for issue to Ships and Naval parties, &c., proceeding to malarious areas.

2. Supply may be obtained by demand direct on the local Army authorities in the area concerned.

3. Demands for requirements are to be prepared in accordance with the following allowances:—

Item.	Denomination of Quantity.	Allowance.
Mosquito spray	Gallons	Malarious areas—9 gallons per 100 men for 28 days Potentially malarious areas or areas where there is an outbreak of dengue fever—6 gallons per 100 men for 28 days—issue to be made on authority of medical officer
Fly sprayers (fit guns)	Number	Highly malarious areas—20 per cent. unit strength. Other areas where mosquito spray is issued—10 per cent. unit strength
Insect repellent lotion	Bottles	1 No. 4 oz. bottle per man (2½ gallons per 100 men) per 28 days, with double issue when in ground contact with enemy; to be issued in malarious and potentially malarious areas only. For scrub typhus, 5 gallons per 100 men per 28 days on authority of medical officer
Malaria oil	Gallons	Malarious areas—50 gallons per 100 men for 28 days Potentially malarious areas—25 gallons per 100 men for 28 days Non-malarious areas—10 gallons per 100 men for 28 days (The authority of the medical officer is required for supply in potentially malarious and non-malarious areas)

(612/219/211.)

16.

CODING BRANCH.

The following amendment is to be made to Navy Order 339 of 1943:—

Paragraph 5 is omitted and the following paragraph inserted in its stead:—

“An Ordinary Coder who fails to pass his qualifying course is to be re-examined after a further period of instruction.”

(349/16/316.)

17.

SUPPLY RATING (A.S.)—NEW RATING.

It has been decided, as a temporary war measure, to adopt the rating of Supply Rating (A.S.) to meet requirements in the various Armament Stores and Armament Store Issuing Ships.

2. The rating will be open only to personnel serving under R.A.N.R. or R.A.N.V.R. engagements. R.A.N.V.R. ratings will be required to transfer to R.A.N.R. engagement.

3. (a) Supply ratings R.A.N.R. and other R.A.N.R. or R.A.N.V.R. personnel will be allowed to transfer to the new rating subject to recommendation and vacancies existing, retaining their present relative rate and seniority.

(b) Transfer is not open to men holding non-substantive ratings other than those unfit for general service, and is in all cases subject to manning requirements.

4. As the positions to be filled are mainly in northern bases, ratings must be medically fit for tropical service.

5. Direct entries from shore will be in the rating of Supply Probationer (A.S.).

6 Advancement.

Supply Probationer (A.S.) to Supply Assistant (A.S.)

Probationary time to be a minimum period of three months, including four weeks' training at Spectacle Island. Advancement to be made on completion of probationary period.

Supply Assistant (A.S.) to Ldg. Supply Assistant (A.S.).

(a) Authority to give rating:—Naval Officer-in-Charge, Flinders Naval Depot.

(b) Nine months' service as Supply Assistant not including probationary time.

(c) Certificate of proficiency in A.S. duties.

(d) Recommended on Form A.S. 507.

Leading Supply Assistant (A.S.) to Supply Petty Officer (A.S.)

(a) Authority to give rating:—Naval Officer-in-Charge, Flinders Naval Depot.

(b) Twelve months' actual service as Leading Supply Assistant (A.S.).

(c) A certificate of proficiency in A.S. duties.

(d) Recommended on Form A.S. 507.

All advancement to be on a temporary basis.

7. Rates of pay are to be those laid down in Naval Financial Regulations and Instructions for the Supply Branch.

8. Applications for transfer are to be dealt with in accordance with Navy Order 251 of 1943, including recommendation, stating time served in armament store duties.

9. In the event of a rating being transferred from armament store duties, he is to be automatically reverted to the rating held immediately prior to transfer to Supply Assistant (A.S.); direct entries from shore are to be reverted to Supply Assistant.

(568/202/857.)

(This Order will be reprinted for posting on Notice Boards.)

18.

LOSSES OF PISTOLS, REVOLVER.

The Naval Board are concerned at the numerous losses of pistols, despite the instructions issued for their safe keeping. Losses of pistols must be treated as a most serious matter, in view of the grave risk of the pistols falling into the hands of criminals or persons ill-disposed to the country's war effort, the temporary disarming of members of the Service required to go armed, and the difficulty of replacing weapons lost.

2. Further, the loss of time and energy expended on investigations and Boards of Enquiry can be ill afforded at present.

3. For these reasons, the importance of the matter is again emphasized, and Commanding Officers, and other authorities concerned, are to ensure that officers and ratings who now hold pistols, or to whom they are issued, are impressed with their personal responsibility for safeguarding such weapons against loss, and that in war, loss of such weapons through negligence is a serious offence.

4. Attention is called to the provisions of K.R. & A.I., Article 1130, which are to be carefully followed, and the disciplinary action taken or, in doubtful cases recommended, should be reported. It is stressed that in every case of loss there is an individual who should be responsible for the safe custody of the weapon, and every endeavour is to be made to establish that responsibility.

5. A large proportion of the losses is due to theft or suspected theft made possible by negligence. Losses in ships frequently are due to insufficient precautions for safeguarding weapons temporarily stowed in "ready use" positions handy for immediate action, to thefts from cabins, or to failure to use a lanyard. When it is necessary to remove pistols from the normal locked stowage racks, special precautions, particularly in harbour, are necessary to prevent easy opportunity of theft.

6. When pistols are not actually being worn, they should be locked up in, for instance, the Quartermaster's desk or similar lock-up, and arrangements made for the key to be secure and instantly available. Where this precaution is not practicable, pistols should be placed in the personal charge of a responsible rating on watch. Attention is called to K.R. & A.I., Articles 1936 and 1938.

7. In shore establishments, losses are almost invariably due to theft, facilitated by the negligence of individuals or by insecure storage arrangements. Special instructions concerning safeguarding of stocks of pistols in Naval Armament Depots and Shore Bases were issued in Navy Office memorandum 109303, dated 12th November, 1943.

8. Scrutiny of Forms A.S. 126 at Navy Office reveals doubt in many cases as to the amount to be charged when pistols are lost by neglect. The cost of replacement of a pistol, revolver, No. 1, is the vocabulary price—£5, plus the percentage charged by Admiralty for issues to Dominion Governments (at present 15 per cent.), plus exchange, the total amount being therefore £7 4s. 2d. In view of Admiralty Fleet Order 349/43, it is approved for the charge to be assessed on this basis, instead of that prescribed in Naval Financial Regulations and Instructions, Article 219, Third Schedule, clause (g). The attention of Commanding Officers and other authorities, however, is drawn to Admiralty Fleet Order 137/43, paragraphs 3 (b) and 4.

9. Attention is drawn also to C.O.R., Article 417, setting out the action to be taken in cases of misappropriation of Government stores, and to Navy Order 18 of 1943, which directed that, when loss of Government stores may be attributable to theft, particulars of the loss are to be reported to the police.

(412/204/212.)

19.

UNIFORM AND CLOTHING FOR WRANS—GYMNASTIC SHOES.

Owing to the rubber position, future purchases of gymnastic shoes for Wran ratings will comprise shoes made of suede leather fitted with reclaimed rubber soles and these shoes will, on exhaustion of existing stocks of the normal type shoes, be issued to meet demands.

2. In order to conserve supplies which are extremely difficult to procure, care is to be taken to ensure that issues of gymnastic shoes are restricted solely for recreational and physical training, *vide* Navy Order 373 of 1942, and the wearing of gymnastic shoes for any other purpose is not permitted.

(420/201/1088.)

20.

WOMEN'S ROYAL AUSTRALIAN NAVAL SERVICE—UNIFORM CLOTHING—AUTHORIZED KIT.

The authorized loan issue of overalls to Range Markers is increased from 1 No. to 2 No.

2. The authorized loan clothing issue to Hairdressers is as follows:—

1 No. Overall.

1 No. Fatigue Hat

2 No. Gowns (S.B. & D.A. pattern).

2 No. Caps (S.B. and D.A. pattern).

3. All copies of Navy Order 375 of 1943 are to be amended accordingly.

(516/201/593.)

21.

OILSKIN ANTI-GAS CLOTHING—UPKEEP AND REPAIR.

In future, 10 per cent. of ratings undergoing instruction in the Gas School at Flinders Naval Depot will receive practical training in the technique of repairing oilskin anti-gas clothing and notation will be made accordingly on page 3 of their Service Certificates. Ratings so trained will then be available to train additional ratings in repair technique.

2. This action has been taken in order that oilskin anti-gas clothing may be repaired on board H.M.A. Ships and in Establishments where ratings having the necessary qualifications are available. *Such repairs are, however, not to be attempted where garments require repairs of a major nature or are considered to be beyond repair. In such cases the normal procedure of return to Victualling Yards for replacement is to be continued.* The question of reconditioning such garments through trade channels will be dealt with by the Victualling Yards.

4. A.F.O. 4086/1943 contains full information regarding the subject.

(434/214/535.)

22.

OFFICE MACHINERY ANNUAL CENSUS.

In order that a complete record of all typewriters, duplicators and other office machinery in use, or on charge, in H.M.A. Ships and Shore Establishments may be maintained, reports are to be forwarded in duplicate through the appropriate Administrative Officers to the Secretary, Naval Board, Victoria Barracks, Melbourne, as soon as possible after 1st February, 1944, giving the following information:—

(a) *Typewriters.*

(i) Office or department where machine is located.

(ii) Size and make of machine.

(iii) Statement showing whether the machines are in full use and whether by centralizing typing or by re-allocating the typewriters any machine may be surrendered.

Note.—The retention of a typewriter over the number fixed by Establishment is not justified unless it can be employed for a minimum period of five hours per diem.

(b) *Duplicators, Press Copying Machines and Printing Presses, Calculating Machines.*

(i) State factory number, size and make.

- (ii) Whether worked by hand or electrically driven.
- (iii) Whether flat or rotary.

(c) *Guillotines.*

Factory number and length of knife.

(d) *Addressograph Machines.*

State factory number.

Note.—Before any machine is included in the report, the description and factory number must be verified by actual inspection. Reports must not be compiled from existing records.

2. All machines surplus to requirements are to be returned to the Naval Store Officer, H.M.A. Naval Yard, Garden Island, Sydney, or the nearest Naval Store Depot.

3. As considerable difficulty is being experienced in obtaining typewriters and having repairs effected, it is necessary that the greatest care be taken of typewriters supplied for official use. Observance of the following procedure will result in longer and more efficient service being obtained:—

- (i) Typewriters should be regularly oiled and cleaned by the operators of the machines, and officers controlling staff should keep a record of all typewriters in use and obtain a statement weekly from each operator certifying that the machine has been cleaned and oiled.
- (ii) Keep the machine covered and *free from dust.*
- (iii) Do not allow stencil sheets to remain in machine overnight. Machines with rubber fitments are damaged when stencil sheets remain in contact with this rubber for any length of time, because of the action of the cellulose solvent used in manufacturing the sheets.
- (iv) Oiling. After the machine has been well brushed out and made clean, then it is advisable to use oil on all bearing parts, sparingly. This should be done at least once a week—even more frequently on machines where the carriage bears on a rod, such as Underwood, Imperial, &c.
- (v) Eraser dust should not be allowed to fall into the centre part of the machine—when erasing, push carriage to one side.
- (vi) Keep the type face thoroughly brushed. Old ink in the type will soon effect the good ink of new ribbons, and shorten the life of the ribbons.
- (vii) At no time use force on any part of the machine. The back space key should not be struck as an ordinary key is struck, not even lightly. It should be pushed. A great amount of mechanical trouble is caused by the impulsive use of the back space key.
- (viii) Whatever make of typewriter is in use, it is important that ribbon spools meant for the left-hand side of the machine should not be placed on the right-hand side, and vice versa. This mistake leads to untold ribbon reverse troubles, and often a breaking of the tension strap and mainspring.

(524/209/706.)

By Authority: H. E. DAW, Government Printer, Melbourne.

RESTRICTED.

(FOR OFFICIAL USE ONLY.)

Commonwealth Navy Order.

Navy Office, Melbourne,

14th January, 1944.

The following Order, having been approved, is hereby promulgated for information and guidance and necessary action.

By direction of the Naval Board,

J. O. Spence
Secretary.

*The Rear-Admiral Commanding H.M.A. Squadron,
and Commanding Officers of H.M.A. Ships,
Officers in Charge of H.M.A. Naval
Establishments, and others concerned.*

TABLE OF CONTENTS.

No.	Subject.
23.	Naval Censorship.
C.360/44.	

NAVAL CENSORSHIP.

These instructions are to be explained to all Naval personnel and the special reprint of this Order for posting on Notice Boards is to be read to the ship's company at least once per quarter. Copies of the reprint are to be kept posted on Notice Boards in Ships and Establishments. New entries are to be informed of these instructions at an early date after their entry.

It is important that all personnel understand that censorship is not applied as a disciplinary measure but as a security precaution to deny to the enemy information of value. Small items of information which appear harmless to the writer, and which in themselves are not of great value, may be of considerable value to the enemy, when added to other small items of information in his possession. It is not sufficient to leave it to censors to cut out doubtful pieces of information from letters and telegrams. Officers and men are to refrain from writing such information in the first place, and are to seek the advice of the ship's censor if they are in doubt. Disobedience or evasion of these censorship instructions is liable to bring disaster to the writers, other personnel, or even the civilian population.

3. Writers, signalmen, telegraphists and messengers are to be specially cautioned to keep silence on board and ashore on matters they may see or hear in the course of their duties.

4. The families and friends of officers and men come to know a good deal about their movements. It is important that they should maintain strict reticence, and that the movements of H.M.A. Ships and other confidential service matters should not be the subject of discussion or correspondence amongst them. Officers and men are to see to the best of their ability that their families and friends observe this rule. The disclosure of Naval and Military information, even when innocently made, is a serious offence, punishable under the laws of the Commonwealth.

GENERAL IMPOSITION OF CENSORSHIP.

5. Censorship is to be established in all H.M.A. Ships as soon as they become ready for sea, whether for trials or on completion, and in all H.M.A. Naval Establishments.

MAIL.

6. The term mail comprises telegrams (which includes internal telegrams, cablegrams and wireless messages), letters, postcards, photographs, sketches, printed matter, packets and parcels.

7. (a) Mail for despatch is to be handed open to the ship's censor except where censorship has been suspended in accordance with paragraphs 14 and 16.

If, however, letters are enclosed in privilege envelopes (see paragraph 28) they may be sealed by the writer.

(b) Mail is to bear the name, rank or rating and official number of the writer except when addressed to a prisoner of war in enemy hands (see paragraph 43).

8. All mail censored in H.M.A. Ships and Establishments is to bear the standard official censor's stamp. The censor's name is to be inserted, but not the date.

9. Telegrams for despatch are to be handed to the ship's censor, and if no objection is seen to the contents and the ship is in a British or Allied port, he is to forward them to the nearest post office in an envelope, marked—"Telegrams from H.M.A. Ship for Transmission," the envelope being closed, dated and signed by the censor and accompanied by the necessary payments. The censor is to endorse on the face of each telegram "Delete Office of Origin," in addition to the "Passed by Censor" Stamp.

10. However, in order that personnel may derive the greatest value from short and unexpected periods of leave, telegrams indicating the whereabouts of the sender may be sent on arrival in port, provided that the ship's name is not mentioned. The approval of the Commanding Officer is to be obtained before the despatch of such telegrams is permitted, and approval is to be given only where the telegram appears desirable in accordance with this paragraph. Telegrams or other communications from which the intended movements of H.M.A. Ships could be deduced, are not to be sent in anticipation of arrival.

11. Parcels are to be handed to the ship's censor wrapped in such a manner as to render examination of their contents convenient.

H.M.A. SHIPS.

12. In all ships having a normal complement exceeding 100, a commissioned officer is to be detailed to carry out the duties of censor. This officer, when it is practicable, is to be one whose ordinary duties are of such a nature as not to be seriously interfered with by his duties as censor, and, if necessary, he is to have a staff detailed to assist him. The entire mail is to be passed through his hands, and he is to witness personally the making up and sealing of the mail bags.

13. In vessels carrying a normal complement of 100 or less, ship-board censorship will not ordinarily be imposed, but all mail is to be handed or forwarded by safe-hand means to the Naval Officer-in-Charge nearest to the port at which the mails are landed, who is to detail an officer to perform the duties of censor. In cases where it is not practicable for mail to be handed or forwarded by safe-hand means to a Naval Officer-in-Charge for censoring, censorship is to be carried out in the ship.

14. In ships giving regular leave in Australia, south of Latitude 20°S., censorship may be suspended at the discretion of the Commanding Officer as soon as regular leave commences. When censorship has been suspended, the posting of mail or the despatch of telegrams on shore is permitted, but it is an offence to divulge in such communications any information which would not be passed by the ship's censor, other than the writer's location as disclosed by the postmark on mail posted ashore. No mention is to be made of the location of the ship. When censorship has been suspended, advice is to be signalled to Naval Board in order that District Censors may be kept informed. Naval Board is to be advised when censorship is re-imposed.

15. The attention of all concerned is to be drawn to the fact that it is advisable to post mail on board; firstly, because postage is free on letters despatched from H.M.A. Ships, whereas full postage must be paid on all letters posted ashore, and, secondly, because mail posted on shore may come into the hands of civil censorship who may not know that censorship has been suspended in the ship. Therefore, this mail will appear to have been posted irregularly, and this may cause delay in delivery.

H.M.A. NAVAL ESTABLISHMENTS.

16. In H.M.A. Naval Establishments situated south of Latitude 20°S., the Commanding Officer may suspend censorship. When naval censorship has been suspended, mail is still liable to civil censorship.

17. Where the normal complement exceeds 100, the same censorship procedure is to be followed as is set out in paragraph 12 for H.M.A. Ships. Uncensored mail for Establishments with a complement of 100 or less is to be forwarded by safe-hand means, for censorship, to the Naval Officer-in-Charge where the least mail delay will be involved.

18. Concession rates of postage are not available for letters posted ashore as the use of the stamp "Naval Service" on envelopes is to be confined to letters posted in the Establishment.

GUIDE TO CENSORABLE MATTER.

19. With a view to indicating the type of information which is classed as censorable matter, the following list has been compiled. Personnel are not to write or otherwise record or pass such information regarding:—

- (i) the past or future movements or the position at time of writing of any ships, whether warships or merchant ships, unless such past movements have been published in the Allied press. This prohibition is to be regarded as covering such movements or locations even though they be only rumoured or surmised, and also covers disclosures of movements or locations by means of references to persons whose location may be known to the addressee of a letter;
- (ii) the routine under which ships' companies are being worked;
- (iii) the conditions of and arrangements at any ports visited;
- (iv) plans of future operations whether rumoured, surmised or known;
- (v) the conditions of the writer's ship or any other ship and of the crews. This does not in any way prohibit general comment on life in ships or establishments, particularly as it relates to the individual, providing it does not convey information of specific value to the enemy, or general encouragement to him;
- (vi) actions or engagements, except as provided hereunder—
 - (a) Mention is not to be made of Fleet actions or other major operations, until they have been disclosed in the press; therefore, where practicable, Commanding Officers of the Ships concerned will be

advised by signal when such information has been published, so that shipboard censorship may be relaxed accordingly.

(b) As actions involving only an individual ship or a small detached group of ships are unlikely to be published in the press, the Commanding Officer may grant permission to personnel to mention such actions in their correspondence. The Naval Board and the Naval Officer-in-Charge where mails are landed for censorship are to be notified by signal when such permission has been granted in order that shore censors may be aware of the relaxation, but in no case are personnel permitted to mention the locality or the date of an action on which there has been no publicity.

(c) Permission is not to be granted by the Commanding Officer in the case of action against enemy submarines.

- (vii) personnel casualties—except with the express permission of the Commanding Officer;
 - (viii) losses of or damage to ships of any sort prior to any official announcement;
 - (ix) information concerning aerodromes, fortifications, search-lights, listening posts, barracks, camps, W/T telephone, signal or cable stations, wharves, docks, or any information relating to the activities of other Services;
 - (x) criticism of the Naval, Military or Air Force of His Majesty or any of His Majesty's Allies, in such a manner as to bring them into disrepute; or
 - (xi) information that may convey to the enemy the efficiency of any other branch of the Fighting Services.
20. It is strictly forbidden for any Naval personnel, unless permitted by other paragraphs of this Order, to—
- (i) keep a diary of any written record of events;
 - (ii) post or give to any other person to post or deliver or receive for posting or delivery a private letter, parcel, or post-card other than through the Naval channels prescribed in this Order;
 - (iii) send, or give to, or request any other person to send a private telegram without first obtaining the approval of the officer detailed for censorship duties;
 - (iv) originate a telephone call other than a local call, without the prior approval of the officer detailed for censorship duties;
 - (v) use note paper bearing any mark which indicates the locality in which a ship is or has been; or

- (vi) send a photograph, picture, postcard or souvenir of a place visited by the ship or send any other article which might disclose a ship's location, past or future movements, without the approval of the Commanding Officer.

Sub-paragraphs (ii), (iii) and (iv) shall not apply to personnel in Establishments where censorship has been suspended, or on long leave.

PHOTOGRAPHY.

21. The Commanding Officer of an H.M.A. Ship or Establishment is to appoint a commissioned officer who will be responsible for the censorship of photographs.

22. It is strictly forbidden, under any circumstances, to—

- (i) take a photograph of any Naval, Military, Air Force or other defence subject, except as prescribed in this Order;
- (ii) take photographs of prisoners of war, except for the purposes of official records and under the instructions of the Commanding Officer;
- (iii) have on board or in a Naval Establishment a camera unless it is registered at the Regulating Office;
- (iv) have, or arrange through any other person to have, except under the conditions prescribed in paragraph 25 below, any photographic film (including cinema film) developed and/or printed in any place other than—
 - (a) on board one of H.M.A. Ships;
 - (b) in one of H.M.A. Naval Establishments; or
 - (c) through nearest Naval Intelligence Office or the Director of Naval Intelligence, Melbourne, when it is impracticable for it to be done on board or in the Establishment;
- (v) send or take any photograph out of the Ship or the Establishment to which a member belongs, unless it has been stamped "Suitable for transmission through the Post—Not for Publication" and signed by the officer appointed by the Commanding Officer to censor photographs.
- (vi) enclose any photographs (whether passed by the censorship officer or not) in a privilege envelope;
- (vii) send any photograph to any newspaper or journal unless it has been stamped by Naval Intelligence Division, Melbourne, as suitable for publication; or
- (viii) take any photograph in any dockyard without the authority of the appropriate Naval Authority; or have any such photograph developed and/or printed except through the channels set out in sub-paragraph (iv) above.

23. When photographs submitted for censorship in a Ship or Establishment are considered unsuitable for transmission through the post, such photographs and relevant negatives are to be impounded and forwarded to the Director of Naval Intelligence, Melbourne.

24. If they are required for intelligence or historical purposes, the owner will be reimbursed to the extent of his out-of-pocket expenses. To avoid waste of material, personnel are to prepare only one print of each exposure before submitting material to the censoring officer.

25. All additional copies taken from photographs which have been stamped in accordance with sub-paragraph (v) of paragraph 22 are also to bear the censorship stamp before being sent or taken out of the Ship or Establishment. This applies also to any photographs or post-cards offered for sale in a Ship or Establishment. When photographs have been stamped in accordance with sub-paragraph (v) of paragraph 22 and personnel on leave, &c., wish to obtain extra copies, under circumstances where Service facilities are not available, they may do so, but the onus of proof that the negatives concerned have been approved by the Ship's censor shall rest with the individual. Otherwise, additional copies of photos must be obtained through the channels set out in sub-paragraph (iv) of paragraph 22 above.

26. The taking of photographs by officers and men of the Royal Australian Navy on board H.M.A. Ships or within H.M.A. Naval Establishments under the rules set out in the preceding paragraphs will be considered as constituting compliance with the terms of the Control of Photography Order; and it will not be necessary for written permits to be given to individuals in possession of cameras.

ADDRESSES FOR MAIL.

27. (i) Special arrangements are made by the Australian Postal Authorities in order to ensure the most expeditious delivery of mails to and from H.M.A. Ships.
- (ii) Mail to be sent ashore in Australian ports is to be headed simply:—H.M.A.S. (Name of Ship), G.P.O.
- (iii) Mail to be sent ashore for posting in foreign ports, where postage stamps and postmarks may be insisted upon by postal officials is not to carry the ship's name, but is to be headed—"Same Address."
- (iv) Any officer or rating who receives notice of draft, from one H.M.A. Ship or Establishment to another is to notify his correspondents promptly that his new address is H.M.A.S. (Name of ship to which drafted), G.P.O.

NOTE.—Personnel of any of H.M.A. Ships should advise their correspondents not to specify any particular G.P.O. such as Melbourne, Sydney, &c. This may lead to letters being sent to that G.P.O., when actually they could have gone forward from the G.P.O. in the State in which the letters were originally posted.

- (v) Officers or men who are proceeding abroad on draft are to advise their correspondents prior to departure to address letters to them, "C/o Senior Naval Officer" or "C/o Fleet Mail Officer" at the base to which they are proceeding.

If such officers or men know the name of the H.M. or H.M.A. Ships to which they will be allotted upon arrival, they are to advise their correspondents to use the address: "H.M.S. (or H.M.A.S.) (Name of Ship), G.P.O."

Correspondents writing to officers or men who are proceeding on draft to the United Kingdom may also address their letters—"C/o Australian Naval Liaison Officer, Australia House, London."

PRIVILEGE ENVELOPES.

28. The system of privilege envelopes will apply to all H.M.A. Ships and Establishments. It is important that all personnel realize that these envelopes are intended solely to enable the writing of private and family matters which it would be undesirable to subject, or which would be embarrassing to the writer if subjected, to naval censorship. Under no circumstances is any other matter or information to be enclosed. Attention is drawn to the danger involved in letters containing other than private and family matters being permitted to leave a ship without censorship. The privilege envelope bears on its face the following certificate, which is to be signed by the sender:—

"I certify on my honour that the contents of this envelope refer to nothing but private and family matters."

29. If the certificate is not signed by the sender, the envelope and its contents are to be destroyed. The envelope is large enough to contain several letters, the contents of which will be covered by the certificate on the outer cover, but, when so used, it is to contain only letters from the person who signs the certificate.

30. Privilege envelopes are to be issued to all ranks and ratings, irrespective of character or class for conduct. Not more than one privilege envelope per officer or man per week is to be issued. In cases where these envelopes are misused, the Commanding Officer may withhold further issues to the offender.

31. Correspondence contained in privilege envelopes is not to be censored by the ship's censor, but will be censored ashore.

32. Under no circumstances are photographs to be enclosed in privilege envelopes, even if the photographs have been passed by the ship's censor, and any photographs so enclosed will be confiscated.

33. The use of privilege envelopes to contain letters which do not refer exclusively to private and family matters is a very serious offence.

34. Privilege envelopes are not to be recovered from the addressees for further use as such envelopes will bear the "Passed by Censor" stamps of civil censorship.

35. All letters enclosed in privilege envelopes leaving a ship are to be forwarded by safe-hand means if there is any danger of their being intercepted and captured by the enemy.

CENSORSHIP PROCEDURE.

36. "Passed by Censor" stamps will ordinarily only be issued to those Ships and Establishments in which censorship is in force, but stamps will also be issued to small ships if they are on detached duties which prevent the landing of mail for censoring by Naval Officers-in-Charge as described in paragraph 13. Stamps will be on charge to the officer appointed as censor and are to be kept locked up when not in use.

The stamp is to be impressed only on envelopes the contents of which have been read and approved by the censor, likewise only on the outer covers of such other mail, the contents of which he has examined and approved.

37. Any system by which officers censor mail written by men of their own division, is to be avoided where practicable. Officers are not to censor their own mail, except with the permission of the Commanding Officer. Censorship is to be done in a place as private as possible, and under no circumstances are the contents of mail being censored to be disclosed to any person other than to an officer authorized for the purpose of dealing with breaches of censorship instructions.

38. Censorship of private mail is instituted solely for security purposes, and it is most undesirable that information obtained thereby should be used as the foundation of a disciplinary charge against any person, except for a breach of security rules. This does not, however, preclude Commanding Officers from taking suitable action should it come to light in the course of censorship that an officer or rating has been guilty of an offence against the ordinary laws of the land.

39. Censorable parts of airgraph letters are to be obliterated. The only safe method of cancelling parts of all other letters is to cut them out. Obliteration by the use of ink, pencil, or crayon is never to be used as a substitute for excision. Alternatively, the letter may be destroyed, the sender being informed so that he can re-write the letter without the matter which it is desired to suppress.

DISCIPLINARY ACTION.

40. In cases where disciplinary action is taken and it becomes necessary for the letter to be produced as evidence, a request is to be made to the Naval Board, or to the Naval Officer-in-Charge, in cases being dealt with locally, for production of the letter.

41. As every effort is being made to avoid delay in Naval mail, it is seldom that the original letter will be available and, therefore, the following procedure will be followed:—

The District Censor will furnish a photograph of the portion of the letter which is the subject of disciplinary action, together with a certificate that the original was part of a letter addressed to the named addressee. The certificate will also give particulars of the date of the letter, the identity of the writer, and the method of posting.

42. This photograph and certificate is to be accepted as *prima facie* evidence in any disciplinary proceedings. This is the procedure prescribed in National Security Regulations, for dealing with civil offences of a like nature.

LETTERS TO PRISONERS OF WAR IN ENEMY HANDS.

43. Writers of mail to prisoners of war are not to indicate in any way that they are naval personnel. The address given for any reply is to be that of a civilian relative or friend. The ship's name is not

to be given. Mail to prisoners of war is not to be subjected to censorship treatment (such as excision, &c.), but is to be stopped or returned to the writer for re-writing if it contains censorable matter.

(The prevention of identification of letter writers as naval personnel is important so that Allied prisoners-of-war addressees will not be subject to undue questioning under pressure by the enemy. The disclosure of ship's names provides information to the enemy as to the composition of our Naval Forces.)

44. The provisions of the whole of this Order are to be thoroughly understood and kept uppermost in mind when writing to prisoners of war. Every care is to be taken not to include any information which may be directly or indirectly of value to the enemy.

DISPOSAL OF MAILS.

45. At ports in Australia, censored correspondence from H.M.A. Ships and Establishments is to be put in a mail bag which is to be tied, sealed and labelled, with a tie-on label marked with the word "Navy," and the address to which the bag is to be sent. The bag is to contain inside (not outside) the identity of the ship. The bag is to be addressed to the Superintendent of Mails at the nearest, or most convenient, General Post Office in Australia, and is to be delivered to the postmaster at the port, by hand, by a selected member of the ship's company.

46. The following letter is to be handed to the postmaster with the mail bag, if the bag is addressed to a place other than where it is put ashore:—

"In pursuance of the arrangements agreed upon between the Navy and the Postal Departments of the Commonwealth of Australia, the bag of the ship's mail now presented should please be forwarded to its destination enclosed in a covering mail bag fastened and addressed in the same manner as an ordinary bag of letter mail."

47. At ports outside Australia, it is not always possible to observe the above procedure as Postal Authorities may insist upon the use of local postage stamps and cancellation of the stamps by postmarks, &c. At ports abroad, therefore, it is the responsibility of the ship's censor to ascertain the requirements of the local post administration. If free postage, or bulk payment, enables the adoption of the sealed bag method of forwarding, as in Australian ports, this is to be used. If, however, postage stamps and postmarks are insisted upon, the ship's name is not to appear in or upon any letters so posted.

48. At all times every care is to be exercised to ensure that no single article of mail or bag of mail, if intercepted, will disclose the position upon any given date of any of H.M.A. Ships.

49. Navy Orders 134 of 1941 and 446 of 1943 are hereby cancelled.
(1835/2/534.)

(The principal provisions of this Order will be reprinted for posting on Notice Boards.)

RESTRICTED.(FOR OFFICIAL USE ONLY.)

Commonwealth Navy Orders.

Navy Office, Melbourne,
18th January, 1944.

The following Orders, having been approved, are hereby promulgated for information and guidance, and necessary action.

By direction of the Naval Board,

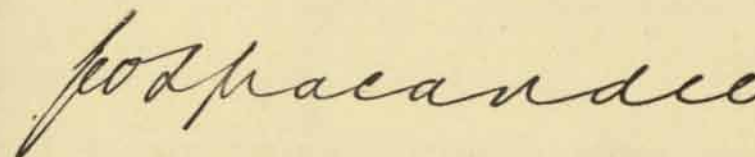

Secretary.

*The Rear-Admiral Commanding H.M.A. Squadron,
and Commanding Officers of H.M.A. Ships,
Officers in Charge of H.M.A. Naval
Establishments, and others concerned.*

TABLE OF CONTENTS.

No.	Subject.
24.	Vice-Admiral A. S. Carpenter, U.S.N.—Valedictory.
25.	Memorial Prizes and Testimonials.
26.	Advancement of Recovered Deserters to Able Seaman or Equivalent Rating.
27.	Deferred Pay of Mobilized Personnel.
28.	Guns—Accidents.
29.	Depth Charge Pistols—I.R. Diaphragms to be Fitted.
30.	Anti-glare Spectacles, Pattern 4074—Supply.
31.	“Official Memorandum—Prices of Clothing, &c., Maintained for Issue on Repayment to Ships’ Companies”. Dated 1st May, 1943—Amendment.
32.	Coal For H.M.A. Ships—Procedure governing Supplies.
33.	Sun Reflecting Device for H.M.A. Ships.
34.	Re-fit of A.M.S. Vessels at Port Adelaide—Replacement of Naval Stores.
35.	Books and Forms.

24.

VICE-ADMIRAL A. S. CARPENTER, U.S.N.—VALEDICTORY.

The following is an extract from a letter addressed to the Prime Minister by Vice-Admiral A. S. Carpenter, U.S.N., on his relinquishment of the command of the Allied Naval Forces in the South-west Pacific Area:—

“On relinquishing command of the Allied Naval Forces, South-west Pacific Area, I wish to express to you my very sincere appreciation of the honour and privilege it has been to me to command the Naval Forces of your country.

The highly efficient performance of duty, splendid co-operation, and loyal support which your officers and ratings have given, has been a direct and superb contribution to the Allied cause, and is but another example of the friendship and mutual respect which is so real between your country and mine.”

(443/202/196.)

(This Order will be reprinted for posting on Notice Boards.)

25.

MEMORIAL PRIZES AND TESTIMONIALS.

Information has been received from the Admiralty that, with the concurrence of the respective Trustees, personnel of the Dominion and Royal Indian Navies are to be regarded as eligible for the award of the following prizes:—

- The John Crocker Memorial Prize Fund.
- The Commander Egerton Prize.
- The Goodenough Medal and Fund.
- The Graham Naval History Prize.
- The Eardley Howard Crockett Prize.
- The Henry Leigh Carslake Prize.
- The Ronald Megaw Memorial Prize.
- The Ogilvy Medal.
- The Robert Roxburgh Memorial Prize.
- The Shadwell Testimonial Prize.
- The Harold Tennyson Memorial Prize.

2. Officers of the Dominion and Royal Indian Navies are already eligible for the following prizes under the terms of the respective Trust Deeds:—

- The Gedge Medal and Prize.
- The Jackson Everett Prize.
- The Boyle Somerville Memorial Prize.

3. By the terms of the Trust Deeds &c. governing the remaining prizes mentioned on pages 164-168 of the Appendix to the Royal Navy List, the Admiralty are precluded from extending them to personnel of the Dominion and Royal Indian Navies.

(448/201/1557.)

26.

ADVANCEMENT OF RECOVERED DESERTERS TO ABLE SEAMAN OR EQUIVALENT RATING.

The advancement of recovered deserters is to be made under the conditions of K.R. and A.I., Articles 406 (4) and 410 as amended by A.F.O. 3614/1942 and A.F.O. 3671/1943.

2. With reference to A.F.O. 3614/1942, paragraph (d), the period of service in the previous branch which may be counted towards the advancement of a rating in his new branch is four to eight weeks, *vide* Navy Order 103 of 1942.

3. In addition to Rear Admiral Commanding, His Majesty's Australian Squadron, Naval Officers-in-Charge and Senior Naval Officers of Ports are authorized to approve of such advancements.

4. Any cases which do not appear to be covered by this Order should be referred to Naval Board for consideration.

(432/221/2894.)

27.

DEFERRED PAY OF MOBILIZED PERSONNEL.

Deferred Pay, accrued in respect of mobilized service of members of the Naval Reserve Forces, will, in future, be paid to members entitled thereto, only on final discharge to shore.

2. Payment will not be made on promotion to Commissioned or Warrant Rank, or on temporary demobilization.

3. This applies also to members of the Women's Royal Australian Naval Service and the Royal Australian Naval Nursing Service.

(556/201/1937.)

(This Order will be reprinted for posting on Notice Boards.)

28.

GUNS—ACCIDENTS.

An accident has recently occurred at an Ordnance Q.F. 40mm. Bofors gun because an attempt was made to sponge out the gun without seeing the bore clear. Attention is drawn to Admiralty Fleet Order 2851/43 wherein it will be seen that accidents are largely due to carelessness.

(432/216/1467.)

29.

DEPTH CHARGE PISTOLS—I.R. DIAPHRAGMS TO BE FITTED.

With reference to Admiralty Fleet Order 4201/43, diaphragms, I.R. Stamp No. 6066, are being re-introduced for use with Marks VII and IX types of depth charge pistols.

2. The following table shows the Stamp No. of diaphragms to be fitted in the marks of pistols indicated:—

Mark of Pistol.	Stamp No. of diaphragm.
† VII-VII**	6066
† VIIA-VII**A	6066
VIII*-VIII***	6067
† IX-IX***	6066
XIII*	6067
XIV-XIV*	6495
XVI-XVI*	6067
(M) Type B-B*	6067

† Diaphragms Stamp No. 6067 may be fitted until diaphragms Stamp No. 6066 are available.

A notation is to be made on the pistol history sheet showing the type of diaphragm fitted.

3. Attention is drawn to Navy Orders 459 of 1942, and 267 and 419 of 1943, regarding precautions to be taken when fitting diaphragms, Stamp No. 6067.

(471/205/1804.)

30.

ANTI-GLARE SPECTACLES PATTERN 4074—SUPPLY.

Stocks of pattern 4074 anti-glare spectacles are now available for issue to replace the polarized sun glasses at present in use.

2. To avoid undue delay in the distribution of the spectacles, a first supply will be made to all ships by the Superintending Naval Store Officer, Sydney. On receipt of this supply, any additional quantities which may be required to complete the allowances shown in Confidential Admiralty Fleet Orders Nos. 1515/40, 1874/40 and 1537/41 should be demanded from appropriate Storing Yards.

(612/236/7507.)

31.

“ OFFICIAL MEMORANDUM—PRICES OF CLOTHING, &c. MAINTAINED FOR ISSUE ON REPAYMENT TO SHIPS' COMPANIES ” DATED 1st MAY, 1943—AMENDMENT.

With reference to Navy Order 265 of 1943, paragraph 3, the following addition is to be made to the abovementioned publication under the heading “ Class II ” on page 6:—

	£	s	d.
Trousers, drill, khaki	0	13	8

(516/201/573.)

32.

COAL FOR H.M.A. SHIPS—PROCEDURE GOVERNING SUPPLIES.

With reference to C.O.R., Article 514A, some doubt has arisen in regard to responsibility for the ordering of, and payment for, coal for H.M.A. and H.M. Ships at certain northern ports. As a general principle, coal requirements should be ordered and paid for in the State in which supply is required, but coal cargoes loaded at Newcastle specifically for Naval purposes, are in all cases to be arranged by the Superintending Naval Store Officer, Garden Island and paid for at Sydney, irrespective of the port of discharge.

2. The responsibility for placing orders and arranging payments at the undermentioned ports is therefore as follows:—

Port.	Nature of Supply.	Officer Responsible for Placing Order and Arranging Payment.
Newcastle, N.S.W.	(a) Bunker coal for H.M.A. and H.M. Ships at Newcastle (b) Naval cargoes of coal for other ports, including — Periodical shipments to Port Moresby “ “ “ Thursday Is. “ “ “ (Bagged coal) “ “ “ Darwin “ “ “ Fremantle	Naval Officer-in-Charge, Newcastle Superintending Naval Store Officer, Sydney
Brisbane, Q'ld	(a) Bunker coal for H.M.A. and H.M. Ships at Brisbane (b) Naval cargoes for northern ports from commercial stocks at Brisbane (c) Naval cargoes or bulk supplies from Bowen coal mines to other ports	Naval Store Officer, Brisbane
Townsville, Q'ld	Bunker coal for H.M.A. and H.M. Ships from commercial stocks at Townsville and Bowen	Naval Officer-in-Charge, Townsville
Cairns, Q'ld	Bunker coal to H.M.A. and H.M. Ships from commercial stocks at Cairns	Naval Officer-in-Charge, Cairns

3. When supplies of coal are effected from bunkers of merchant vessels to H.M.A. and H.M. Ships and/or Naval shore stocks, claims for the cost of the coal so transferred are in all cases to be forwarded to the Director of Naval Stores, Navy Office, for necessary action as regards payment.

(401/213/478.)

33.

SUN-REFLECTING DEVICE FOR H.M.A. SHIPS.

Approval has been given to the addition of the under-mentioned item to the Lists of Special Allowances of Naval Stores for all H.M.A. Ships, excluding those employed on harbour duties, as indicated hereunder:—

Patt. No.	Description.	Qty.	Remarks.
—	Sun-reflecting device	1(a)	(a) For each 50 men in complement. Minimum quantity to be provided:— 1 No. for Air Sea Rescue Vessels and M.Ls. 2 No. for larger vessels

2. Supply of these items to all H.M.A. Ships concerned, in accordance with the above allowances, will be effected without demand as follows:—

To Vessels based on Brisbane—By the Naval Store Officer, Brisbane.

To Vessels based on Fremantle—By the Naval Store Officer, Fremantle.

To Vessels based on Melbourne—By the Officer-in-Charge, Naval Store Depot, Melbourne.

To all vessels other than those referred to above—By the Superintending Naval Store Officer, Sydney.

(514/201/2551.)

34.

**RE-FIT OF A.M.S. VESSELS AT PORT ADELAIDE—
REPLENISHMENT OF NAVAL STORES.**

It is desired that A.M.S. Vessels proceeding to Port Adelaide for re-fit purposes should replenish with naval stores, in accordance with established procedure, before arrival at Port Adelaide. Requirements of naval stores should, therefore, be obtained by such vessels, from the nearest Naval Store Depot before proceeding to the above-mentioned port for re-fit.

(612/201/5423.)

35.

BOOKS AND FORMS.

The under-mentioned forms have been revised. Distribution will be effected, on demand, by the Superintending Naval Store Officer, Sydney, when stock of the existing form is exhausted:—

A.S. 66 (inside).—Remittance List.

(480/202/4443.)

A.S. 329r.—Teleprinter Check Sheet.

(480/202/4490.)

A.S. 1124.—Return of Wireless Telegraph Ratings Qualified or Requalified.

(480/202/4498.)

R.A.N.R. 11.—Application for Volunteer Officers' Decoration or Volunteer Long Service and Good Conduct Medal.

(480/203/500.)

2. The under-mentioned forms have been revised and renumbered. Distribution will be effected, on demand, by the Medical and Dental Store Officer, Sydney, when stock of the existing forms is exhausted:—

A.M. 46 (late A.S. 446).—Medical History Sheet for Naval Ratings.

A.M. 46 (late A.S. 446).—Medical History Sheet for Naval Ratings. Continuation.

A.M. 46w (late A.S. 446w).—Medical History Sheet. Officers.
A.M. 46x (late A.S. 446x).—Covers for Medical History Documents. Officers.

A.M. 46y (late A.S. 446y).—Medical History Sheet. Officers.

A.M. 46z (large) (late A.S. 446z).—Receipt for Medical History Documents.

(480/201/3174.)

3. The under-mentioned forms have been introduced for use in the R.A.N. in lieu of the Admiralty Forms S. 576 and S. 576s. First supply will be issued, without demand, by the Medical and Dental Store Officer, Sydney:—

A.M. 121w (late S. 576).—Gonococcal Case Sheets.

A.M.S. 121z (late S. 576s).—Syphilis Case Sheet.

(A.F.O. 6138/1942.)

(480/202/4347.)

RESTRICTED.(FOR OFFICIAL USE ONLY.)

Commonwealth Navy Orders.

Navy Office, Melbourne,

25th January, 1944.

The following Orders, having been approved, are hereby promulgated for information and guidance, and necessary action.

By direction of the Naval Board,

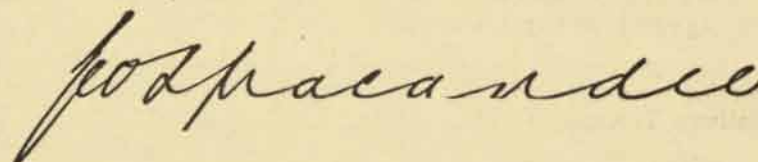

Secretary.

*The Rear-Admiral Commanding H.M.A. Squadron,
and Commanding Officers of H.M.A. Ships,
Officers in Charge of H.M.A. Naval
Establishments, and others concerned.*

TABLE OF CONTENTS.

No.	Subject.
36.	Letters Found Amongst Effects of Deceased Personnel.
37.	Travel by Rail of Members of the Defence Forces Whether Travelling on Duty or Home Leave, or Paying Their Own Fare.
38.	Gun Trials—Procedure.
39.	Butts for Guns Machine Vickers .303-in. on Single A.A. Mountings.
40.	Rockets Illuminating 3½ lb.—Prematures.
41.	Detonators, Percussion, Watertight, Mk. VII, Lot 141, B.R. 8/41—Withdrawal from Service.
42.	Ammunition—Miscellaneous A.A.D. Weapons—Tails, Propelling Rockets U., 2 inch, Mark II filled Cordite, Lot B.S. 7911—Restriction.
43.	Despatch of Naval Armament, Gun-mounting and Torpedo Stores to Melbourne.
44.	Cartridges Q.F. 4-inch XVI* Gun—Assembled with Unsuitable Cases—Withdrawal.
45.	Mines Washed Ashore—Rendering of Reports.
46.	Blue Caps for Officers and Men Proceeding to the United Kingdom.
47.	Australian Defence Canteen Service Clubs.
48.	Return of Empty Gas Cylinders.
49.	Motor Transport Forms.
50.	Telegrams for Royal Netherlands Navy in Australia.
51.	Discrepancies in Stores Shipped—Reports A.D. 690 and O. 9.
52.	Rockets, P.A.C., and Snowflakes—Precautions When Carrying Out Practices or Demonstrations.
53.	Fuzes, No. 401, Mk. II, Lot 146 V.A.D. Filled 10/41—Withdrawal From Service for 100 per cent. Examination.
54.	Marking of Cartridges With Sub-Lot XJ—M.Ls.
55.	Royal Australian Naval Women's Services—Uniform and Clothing—Authorized Kit.
56.	Naval Motor Vehicles—Accidents.

36.

LETTERS FOUND AMONGST EFFECTS OF DECEASED PERSONNEL.

Correspondence found amongst the effects of deceased personnel is to be carefully examined by a responsible officer and, as considered advisable, returned to sender, sent to next-of-kin or destroyed.

2. As a general rule, private letters which do not contain any important matter are to be destroyed.

(557/201/169.)

37.

TRAVEL BY RAIL OF MEMBERS OF THE DEFENCE FORCES WHETHER TRAVELLING ON DUTY OR HOME LEAVE, OR PAYING THEIR OWN FARE.

In order to effect proper control of travel, the transportation of all Service personnel travelling in uniform is to be arranged through the Railway Transport Officer.

(631/201/975.)

(This Order will be reprinted for posting on Notice Boards.)

38.

GUN TRIALS—PROCEDURE.

It is observed from reports of gun trials that the standard procedure is not followed in all cases.

2. The attention of D.E.M.S. Staff Officers and Port Gunnery Officers is drawn to B.R. 292, Instructions for the Maintenance of Naval Ordnance and Gun Mountings 1942, Appendix IV, Notes on Gun Trials

(490/201/1848.)

39.

BUTTS FOR GUNS MACHINE VICKERS .303-IN. ON SINGLE A.A. MOUNTINGS.

A shoulder butt has been designed to facilitate the use of 0.303-in. Vickers guns on A.A. Mountings.

2. To attach the butt, remove the oil brushes from the handle grips, place the holes in the butt over the top of the handle grips and secure by screwing in the oil brushes tightly.

3. Butts required by H.M.A. Ships and D.E.M. Ships are to be demanded from the nearest base.

4. Bases are to demand their requirements from the Armament Supply Officer, Sydney.

(490/212/802.)

40.

ROCKETS ILLUMINATING 3 $\frac{3}{4}$ LB.—PREMATURES.

As experience has shown that a proportion of prematures is to be expected when firing rockets, illuminating, 3 $\frac{3}{4}$ lb., these rockets are, in future, to be fired, the following precautions being observed:—

- (i) Clamp the Schermuly pistol at approximately 70° elevation to a fixed rest and fire by lanyard, keeping well clear.
- (ii) As an added precaution anti-flash helmet and gloves should be worn.

(471/208/1059.)

41.

DETONATORS. PERCUSSION, WATERTIGHT. MARK VII. LOT 141, B.R. 8/41—WITHDRAWAL FROM SERVICE.

Appended for information and action as necessary is a copy of Admiralty Fleet Order 5234/43 which has not yet been promulgated on the Australia Station:—

- “All detonators, percussion, watertight, Mark VII of Lot 141, B.R. 8/41, in service are to be withdrawn.
2. All ships are, therefore, to land detonators, percussion, watertight, of this lot at the nearest Naval armament depot at next opportunity, and to draw a similar quantity of another lot in replacement.
3. All detonators of the above lot landed from ships or held in store are to be destroyed in accordance with R.N.A.S. Part II, Article 782.”

(471/201/1459.)

42.

AMMUNITION — MISCELLANEOUS A.A.D. WEAPONS — TAILS, PROPELLING ROCKETS U, 2-IN., MARK II, FILLED CORDITE, LOT B.S. 7911—RESTRICTION.

Appended for information and action as necessary, is a copy of Admiralty Fleet Order 5227/43, which has not yet been promulgated on the Australia Station:—

- “Owing to missfires, tails, propelling rocket U, 2-in., Mark II, containing cordite of Lot B.S. 7911, filled KBY. 9/42 are not to be used. Any rockets of this lot on board ships should be landed at nearest N.A. Depot, where they should be retained pending disposal instructions.”

(471/208/1058.)

43.

**DESPATCH OF NAVAL ARMAMENT, GUNMOUNTING AND
TORPEDO STORES TO MELBOURNE.**

The following amendments are to be made to Navy Order 420 of 1943:—

Paragraph 1. After "Victorian Ports" add:—

"and for onward shipment to Tasmania"

Delete "Assistant Armament Supply Officer" and insert "Deputy Armament Supply Officer"

Paragraph 2. After "Victorian Ports" add:—

"and for onward shipment to Tasmania"

Delete "Assistant Armament Supply Officer" and insert "Deputy Armament Supply Officer"

Paragraph 4. Add:—

"Signals relating to such consignments should be repeated to the Deputy Armament Supply Officer, Maribyrrnong."

(612/202/3238.)

44.

**CARTRIDGES Q.F. 4-IN. XVI* GUN—ASSEMBLED WITH
UNSUITABLE CASES—WITHDRAWAL.**

Appended for information and action as necessary is a copy of Admiralty Fleet Order 5226A/43, which has not yet been promulgated on the Australia Station:—

"Cartridge cases for Q.F., 4-in., Mark XVI* guns, Mark II, Lot 87, of Bull Point manufacture, restricted for use with star shell charges only, have been inadvertently assembled with S.A.P.T., H.E., H.E.T., and Practice Projectiles H.A. and L.A. at Glascoed between May, 1943, and August, 1943.

2. All ammunition on board ships for Q.F., 4-in., Mark XVI* guns, other than star cartridges, assembled at Glascoed between May, 1943, and August, 1943, should be examined, and any found to be made up with cases Mark II, Lot 87, of B.P. manufacture is to be returned to the nearest N.A. depot at the first opportunity and other ammunition drawn in lieu. This ammunition may be regarded as coming under Category (b) of C.A.F.O. 991/42.

3. N.A. depots are to set aside any in store and/or subsequently received, reporting to D.A.S., Room 95, Block "B", Einsleigh Hutments, Bath, as requested by A.S. 14264/43/B. 95, dated 16th October, 1943, particulars of quantities set aside. Nil returns are not required.

(C.A.F.O. 991/42.)"

(408/207/2221.)

45.

MINES WASHED ASHORE—RENDERING OF REPORTS.

With reference to Navy Order 448 of 1942, reports on mines rendered safe are being received with the following common errors:—

- (i) No reference made to the position of the A.E. switch in case of German Y* mines.
- (ii) Reports not being forwarded on Form S. 1516, which has been issued to Naval Officers-in-Charge.
- (iii) Serial numbers, or other markings, omitted.

2. With reference to sub-paragraph (iii) above, in the case of British Mark XIV mines, serial numbers will be found as follows:—

- (a) On the edge of the rim of the top flange.
- (b) On the mechanism plate.
- (c) On the charge case.

All three numbers should be reported, if possible, but any one number is sufficient to identify the mine.

(549/201/139.)

46.

**BLUE CAPS FOR OFFICERS AND MEN PROCEEDING TO THE
UNITED KINGDOM.**

With reference to Navy Order 191 of 1943, it has been decided that, in future, provision of the blue caps referred to is to be made before personnel—officers and men—leave Australia.

2. Paragraphs 3 and 4 of the above Order are cancelled.

(494/203/526.)

47.

AUSTRALIAN DEFENCE CANTEEN SERVICE CLUBS.

It is notified for the information of all concerned, that the following clubs have been established by the Australian Defence Canteens Service—

Officers (Residential).

No. 1	A.D.C.S. Officers' Club,	Townsville.
2	" "	Cairns.
3	" "	Atherton, North Queensland.
4	" "	Savoy Hotel, Perth.
5	" "	Port Moresby.
7	" "	Hotel Daniel, Brisbane.

Other Ranks (Residential).

No. 9	A.D.C.S. Club,	Marcus Clark Building, Railway-square, Sydney.
10	" "	Craig's Building, Elizabeth-street, Mel- bourne.
11	" "	St. Oswald's, 137 North Quay, Brisbane.
12	" "	Wickham-terrace, Brisbane.

Other Ranks (Non-Residential).

No. 13	A.D.C.S. Club,	Port Moresby.
14	" "	Milne Bay.
15	" "	33-36 Mile Area, Adelaide River, Northern Territory.
16	" "	56 Mile Area, Adelaide River, Northern Territory.
17	" "	67-69 Mile Area, Adelaide River, Northern Territory.
18	" "	Atherton, North Queensland.

(This Order will be reprinted for posting on Notice Boards.)

(462/201/2274.)

48.

RETURN OF EMPTY GAS CYLINDERS.

Considerable difficulty is still being experienced in satisfying requirements of gas, owing to the shortage of gas cylinders. The attention of all concerned is drawn to the provisions of Navy Order 372 of 1942, and to the necessity for the prompt return of all empty gas cylinders to the nearest Naval Store Depot.

(437/201/712.)

49.

MOTOR TRANSPORT FORMS.

Form N.M.T. 1 "Requisition for Use of Official Motor Car" has been revised and is now printed on paper instead of cardboard as hitherto and made up in pads of 100 sheets.

2. Form N.M.T. 2 "Daily Record—Motor Trucks" is also printed on paper and made up in pads of 100 copies.

3. Stocks will be maintained at Navy Office and supplies will be issued on demand as required.

4. Existing stocks of Forms N.M.T. 1 and N.M.T. 2, printed on cardboard, are to be used until exhausted.

(584/201/475.)

50.

TELEGRAMS FOR ROYAL NETHERLANDS NAVY IN AUSTRALIA.

The Senior Officer, Royal Netherlands Navy in Australia, has requested that, in order to avoid confusion, telegrams regarding purely Naval matters be addressed to the Senior Officer, Royal Netherlands Navy in Australia (M.C.A.), Melbourne, and that addresses such as "Commander, Netherlands Forces in Australia (CNF)" or "Onderbevelhebber Strijdkrachten Oosten" be not used for this purpose.

(443/203/517.)

51.

DISCREPANCIES IN STORES SHIPPED—REPORTS A.D. 690 AND 0. 9.

With reference to Navy Order 684 of 1943, paragraph 1, for "naval victualling and ordnance stores" read "Naval, Naval Victualling and Naval Ordnance Stores."

(612/254/162.)

52.

ROCKETS, P.A.C., AND SNOWFLAKES—PRECAUTIONS WHEN CARRYING OUT PRACTICES OR DEMONSTRATIONS.

Appended for information and necessary action is copy of Admiralty Fleet Order 5484/43 which has not yet been promulgated on the Australia Station:—

"Rockets of the P.A.C. and Snowflake type may, in exceptional cases, prematurely explode.

When practice firings or demonstrations with these rockets are carried out, precautions should be taken against this contingency, personnel being kept under cover so far as is practicable."

(471/208/1063.)

53.

FUZES No. 401, MARK II, LOT 146 V.A.D. FILLED 10/41—WITHDRAWAL FROM SERVICE FOR 100 PER CENT. EXAMINATION.

Appended for information and necessary action, is copy of Admiralty Fleet Order 5481/43, which has not yet been promulgated on the Australia Station:—

"All fuzes No. 401, Mark II, Lot 146, V.A.D. 10/41 on board H.M. ships and D.E.M.S. at home and abroad are to be landed at the first opportunity for examination. These fuzes are to be regarded as coming under Category (b) (C.A.F.O. 991/42).

2. D.E.M.S. Staff Officers should make the necessary arrangements in regard to merchant vessels.

3. At naval armament depots, home and abroad, all fuzes of this description, together with any received under this order from ships, are to be forwarded to Naval Armament Supply Officer, Woolwich, for Inspector of Naval Ordnance, Woolwich, the packages being marked "C.I.N.O. 4397/43 for 100 per cent. examination." Despatch to be reported to Director of Armament Supply (B. 89), Bath."

(471/209/1282.)

54.

MAKING OF CARTRIDGES WITH SUB-LOT XJ—M.L'S.

It has been decided that the provisions of Navy Order 316 of 1942 are to apply to 3-pdr. ammunition issued to motor launches.

2. Action is therefore to be taken in accordance with the above Order to have the XJ marking applied to ammunition already on board these vessels, and for future supplies to be marked XJ prior to issue.

(471/202/1313).

55.

ROYAL AUSTRALIAN NAVAL WOMEN'S SERVICES—UNIFORM AND CLOTHING—AUTHORIZED KIT.

The authorized articles of loan clothing for V/Signallers, Telegraphists and Messengers on duty in Port War Signal Stations, *vide* paragraph 4 (g) of Navy Order 375 of 1943 have been increased to the following:—

- 1 no. jersey, seaman's;
- 2 prs. stockings, heavy, woollen;
- 2 prs. knickers, heavy, woollen;
- 2 no. overalls;
- 1 no. fatigue net.

2. All copies of the above Navy Order held are to be amplified accordingly. Note (iv) shown on page 6 is also to be amplified to read "Oilskin clothing, watchcoats and sea boots may be issued, on loan, as necessary."

(516/201/622.)

56.

NAVAL MOTOR VEHICLES—ACCIDENTS.

Several accidents have occurred recently in which Naval Motor Vehicles were involved and were caused by negligence on the part of the Naval driver. In some cases, serious bodily injury was caused to Naval personnel and civilians, and considerable expenditure was involved in the repair of damage sustained by the vehicles concerned.

2. The attention of Commanding Officers is drawn to the necessity of impressing on all concerned that the utmost care is to be taken in driving Naval vehicles and that Naval drivers must conform generally to Civil Traffic Regulations.

3. Where negligence is proved, suitable disciplinary action is to be taken against the driver concerned and consideration given to the cancellation or suspension of the rating's Naval Driving Licence.

4. An error of judgment or lack of care on the part of the driver whilst reversing is a frequent cause of accidents to motor vehicles. When this operation is unavoidable, the driver is to take every precaution, before driving in reverse, to ensure that the way is clear in order to avoid running back into another vehicle or object.

(638/202/1762.)

RESTRICTED.(FOR OFFICIAL USE ONLY.)**Commonwealth Navy Orders.**

Navy Office, Melbourne,
1st February, 1944.

The following Orders, having been approved, are hereby promulgated for information and guidance, and necessary action.

By direction of the Naval Board,

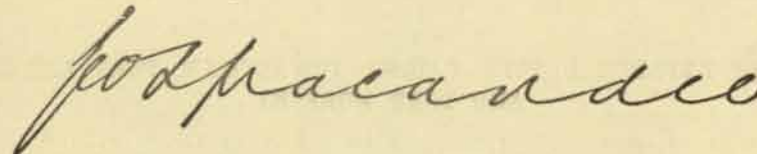

Secretary.

*The Rear-Admiral Commanding H.M.A. Squadron,
and Commanding Officers of H.M.A. Ships,
Officers in Charge of H.M.A. Naval
Establishments, and others concerned.*

TABLE OF CONTENTS.

No.	Subject.
57.	H.M.A. Ships Attached to Eastern Fleet—Service Certificates and Pay Accounts.
58.	Boom Defence Depots—Cairns, Townsville, Port Kembla and Port Moresby.
59.	Navigation Courses.
60.	Coding Branch.
61.	Deprivation and Restoration of Good Conduct Badges, R.A.N.R.
62.	Teleprinter Operators.
63.	Cartridges M.L. 9.5-in. D.C.T. Cordite H.S.C.T. 124/058 3 oz. 14 drms. Mk. II—Withdrawal.
64.	Igniters, Torpedo, Mark XI—Lot No. 144, Filled S.W.Y.N 9/41—Withdrawal (A.F.O. 5738/43).
65.	Depth Charge Thrower Pistols—Spares.
66.	Loss of Ventilating Fan.
67.	Emergency Rations for Aircraft Operating From H.M.A. Ships.
68.	Warranty Period of Canned Provisions.
69.	Inglefield Clips and Unserviceable Flags—Return to Store.
70.	First-Aid Medical Sets.
71.	Tunics, Drill With Blue Facings—Shedding of Dye.
72.	Misappropriation of Government Stores—Reports to Civil Police.

57.

**H.M.A. SHIPS ATTACHED TO EASTERN FLEET—SERVICE
CERTIFICATES AND PAY ACCOUNTS.**

H.M.A. Ships serving with Eastern Fleet are continually receiving correspondence concerning pay accounts and requests for service certificates from Ships and Establishments in Australia.

2. It should be noted that all requests for information concerning pay and service certificates are to be addressed to the R.A.N. Accountant Officer, Colombo.

(443/201/1256.)

58.

**BOOM DEFENCE DEPOTS—CAIRNS, TOWNSVILLE, PORT KEMBLA
AND PORT MORESBY.**

With reference to paragraph 4 (a) of Navy Order 277 of 1942, Boom Depots at Cairns, Townsville, Port Kembla and Port Moresby have been established, accounts being carried in *Platypus*, *Magnetic*, *Penguin* and *Basilisk* respectively.

2. The conditions of Navy Order 277 of 1942 are to apply to these Depots.

(449/202/270.)

59.

NAVIGATION COURSES.

A Navigation School has been established in H.M.A.S. *Penguin* and will be under the direction of the Port Educational Officer, Sydney.

2. The following (N) courses will be carried out:—

(a) Officers from Fairmile School.

(b) Officers from A/S School.

(c) Officers from the Senior Reserve Officers' Course, held at Flinders Naval Depot.

(d) N* Course.

(e) Midshipmen, R.A.N.R. (S).

3. Officers serving in H.M.A. Ships which may be in Sydney from time to time should be encouraged to make use of the instructional facilities of the School.

(600/209/139.)

60.

CODING BRANCH.

The following amendments are to be made to Navy Order 339 of 1943:—

Paragraph 2 (ii) (b). Cancel and substitute—

“Pass Professional Examination in accordance with A.F.O. 885/1943. The examination will be held on the 1st Wednesday in each quarter and all papers will be set by H.M.A. Signal School. The names of candidates are to reach the office of the Naval Officer-in-Charge, Flinders Naval Depot, by the 15th of the preceding month.

Where a Qualified Signal Officer, Base Signal Officer, or Communications Branch Warrant Officer is borne, worked papers should be corrected locally.

Forms A.S. 1124 should be forwarded in the usual manner.

If candidates sit for examination in Establishments where the above-mentioned officers are not available, worked papers are to be forwarded to H.M.A. Signal School for correction.”

2. Paragraph 2 of Navy Order 450 of 1942 is cancelled.

(349/16/316.)

61.

**DEPRIVATION AND RESTORATION OF GOOD SERVICE BADGES
R.A.N.R.**

The provisions of A.F.O. 1904/43 have been adopted for Deprivation and Restoration of Good Service Badges of mobilized personnel of the Royal Australian Naval Reserve.

2. Navy Order 167 of 1940 is cancelled.

(416/201/977.)

62.

TELEPRINTER OPERATORS.

The following amendment is to be made to Navy Order 258 of 1942:—

Paragraph 6.—Delete “A.F.O. 2015/1941, paragraphs 8 and 9” and substitute “A.F.O. 4794A/1943 paragraph 13.”

(349/16/355.)

63.

**CARTRIDGES M.L. 9.5-IN. D.C.T., CORDITE H.S.C.T. 124/058, 3 OZ.
14 DRS. MK. II—WITHDRAWAL.**

All cartridges M.L. 9.5-in. D.C.T., cordite H.S.C.T. 124/058 3 oz. 14 drs. Mk. II on board H.M.A. Ships are to be landed for return to the nearest Naval Armament Depot at the earliest opportunity and cartridges M.L. 9.5-in. D.C.T., cordite H.S.C.T. 134/055 4 oz. 0 drs. Mk. XII drawn in lieu. If the latter are not available, 3 oz. 12 drs. Mk. IX cartridges may be issued as a temporary measure.

2. Naval Armament Depots.

All stocks of the 3 oz. 14 drs. cartridges in store and returned from ships are to be broken down for recovery of components.

(471/205/2016.)

64.

**IGNITERS, TORPEDO, MARK XI—LOT No. 144, FILLED SWYN.
9/41—WITHDRAWAL (A.F.O. 5738/43.)**

Igniters, Torpedo Mark XI. of Lot No. 144 filled SWYN. 9/41 are to be withdrawn from service and appropriated for use in "Brake Machine only."

2. Any igniters of this lot number on board H.M.A. Ships are to be landed at the nearest Naval Armament Depot and others drawn in lieu.

(666/206/1534.)

65.

DEPTH CHARGE THROWER PISTOLS—SPARES.

Navy Order 501 of 1943 is to be amended as follows:—

Paragraph 1. Add:

"and to all other classes fitted with 4 throwers."

(471/205/1900.)

66.

LOSS OF VENTILATING FAN.

The disposal of Crossle Ventilating Fan, 12½-in., 2220 volt, Serial No. J.L. 490 cannot be traced.

2. Reports should be forwarded to the Director of Naval Stores, Navy Office, Melbourne, by all Ships and Establishments, stating whether this fan and the necessary spares are held.

3. Particulars of the serial numbers of all fans of this size and manufacture in H.M.A. Ships and Establishments should also be furnished.

(612/207/2704.)

67.

**EMERGENCY RATIONS FOR AIRCRAFT OPERATING FROM H.M.A.
SHIPS.**

All aircraft operating from H.M.A. Ships are to be supplied with the following Emergency Rations:—

Soya Beans in Tomato Sauce, in 8-oz. tins	..	3 lb.
Sardines in 4-oz. tins	3 lb.
Biscuits (Currant Luncheon) in 8-oz. packets	..	1 lb.
Acid Drops	1 lb.
Sultanas	1 lb.
Malted Milk Tablets (compressed) in 3¼-oz. bottles	6½ oz.	
Tablets, Water Sterilization complete (2 bottles)	..	1 tin (a)
Chewing Gum, 1d. packets	3 No.
Spoons, Tea, N.S.	1 No.
Tin-opener	1 No.
Knife, medium	1 No.
Matches, Safety	2 boxes
R.A.A.F. Form E/E 85	1 No.
Contained in		
Cover, fabric	1 No.
Container, tin, ½-pint with lever top	1 No.

Also

Water, 35-oz. cans, hermetically sealed 8 No. (b)

The 8 No. cans are to be enclosed in a tin box to be made on board measuring approximately 9 in. x 9 in. x 4½ in. with a readily removable top.

Notes:

(a) Water bottles of aluminium are best suited for using these tablets. One white tablet is added to the water bottle after filling from any source not definitely known to be pure and drinkable, and, after shaking, it is left to stand for half an hour. A blue tablet is then added and, after shaking, the water will be drinkable.

(b) In addition to this, one filled water bottle per person shall be carried.

2. To provide against the possibility of the Emergency Flying Ration carried in the aircraft not being available to aircrews if, and when, required, the following special Flying Ration is to be carried on the person by each member of an aircrew:—

Apricot Block	2 oz.
Nuts, Assorted, Shelled	2 oz.
Barley Sugar	2 oz.
Lexias, or Seeded Raisins or Muscatels	4 oz.
Chocolate Slab, American D type ration	4 oz.
Tomato or Pineapple Juice	8 oz.

3. Where possible, component parts of both Emergency Flying Ration and Special Flying Ration are to be drawn from Service Stocks in H.M.A. Ships, and the other items, if available, from the Ship's canteen. Items not available from either of these sources are to be obtained from R.A.A.F. stocks where possible. A small supply of cans, water, 35 oz. hermetically sealed, is being obtained and will shortly be available on demand from any H.M.A. Victualling Yard, or from the Base Accountant Officer at Darwin, Cairns, Townsville, Hobart or Adelaide.

4. The Emergency Flying Ration contains food and drinking water for one man for 12 days. It is for emergency use only and shall not be broached except under orders of the senior member present.

5. C.O.R., Article 425, will be amended accordingly in due course.

(668/201/2624.)

68.

WARRANTY PERIOD OF CANNED PROVISIONS.

It is not practicable, under present conditions, for all supplies of canned fruit and vegetable products to be warranted for the full periods shown in C.O.R., Article 440, and the following reduced warranty periods will apply to all purchases of these items effected after 22nd June, 1943:—

- | | |
|---|---|
| (a) Canned Fruit—(other than varieties in paragraph 3 below). | 12 months from 30th April in each year. |
| (b) Jams and Marmalade— | <p>Apricot—12 months from 28th February.</p> <p>Plum, Fig and Pear—12 months from 31st March.</p> <p>Berry Group, Mixed Berry varieties—12 months from 31st March.</p> <p>Peach, Quince, Quince Jelly—12 months from 30th April.</p> <p>Melon group, Apple Jelly—12 months from 31st May.</p> <p>Marmalade—12 months from 30th September.</p> <p>Jams made from pulp and special orders—13 months from the date of manufacture.</p> |
| (c) Tomato Products— | 12 months from 30th April in each year. |
| (d) Vegetables— | <p>Asparagus—12 months from 31st December.</p> <p>Canned Vegetables, Meat and Vegetables, Pork and Beans—13 months from date of manufacture.</p> |

2. No warranty period is applicable to such canned goods packed in cans larger than the 30-oz. size, but manufacturers are asked to guarantee that the contents of the larger-sized cans are of good quality and equal in every respect to the quality of goods packed in smaller containers.

3. Similar information relating to the warranty expiry dates of the following products will be notified as early as practicable:—

Tomato and Fruit Pulp
Canned Pineapples and Pineapple Products
Gooseberries, Strawberries, Raspberries, Loganberries
Plums, Blackberries, Cherries and Black Currants.

4. The date on which the warranty expires will continue to be inserted on all Supply Notes covering the supply of provisions from H.M.A. Victualling Yards and Depots.

(668/216/426.)

69.

INGLEFIELD CLIPS AND UNSERVICEABLE FLAGS—RETURN TO STORE.

A recent review of stocks of Patterns 100 and 101 Inglefield Clips indicates that there has been an unduly large wastage of these items.

2. Arrangements are to be made, therefore, to ensure that all unserviceable flags are returned, complete with Inglefield Clips, to the nearest Naval Store Depot at the first opportunity after they become unserviceable.

3. Any Inglefield Clips at present held on board surplus to requirements are also to be returned to the nearest Naval Store Depot.

(612/218/228.)

70.

FIRST-AID MEDICAL SETS.

The term—Scale “A”—as applied to the haversack of Medical First-Aid Stores has been abolished. Copies of the printed scale held by H.M.A. Ships and Establishments are to be destroyed and replaced.

2. The term—Scale “F.1.”—has been substituted therefor and copies of the revised scale may be obtained upon application to the Medical and Dental Store Officer, Royal Edward Victualling Yard, Pyrmont, New South Wales.

(612/213/2571.)

71.

TUNICS, DRILL WITH BLUE FACINGS—SHEDDING OF DYE.

With reference to Navy Order 663 of 1943, it is notified that the initial washing of tunics with blue facings, also other types of garments with blue facings, in 50 per cent. salt and 50 per cent. fresh water results in very little shedding of the blue dye.

(434/201/3473.)

**MISAPPROPRIATION OF GOVERNMENT STORES—REPORTS TO
CIVIL POLICE.**

Navy Order 18 of 1943 directed that, in all instances where loss of Government stores may be attributed to theft, particulars of the loss were to be reported to the Police Authorities. It has been observed, however, that reports are not being made to the Police in respect of losses of stores occurring in rail and steamer consignments where the loss is due to pillage.

2. Reports of such losses should be made to the Police when—

- (a) deficiencies are clearly due, or strongly suspected as being due, to pillage; and
- (b) the value of the stores lost exceeds £1.

3. Where the pillage is detected before delivery is taken, the responsibility for advising the Police will rest with the shipping company or Railway Department concerned; where the pillage is not detected until the packages are received in store, it will be the responsibility of the receiving officer to report the matter to the Police.

(612/254/302.)

RESTRICTED.

(FOR OFFICIAL USE ONLY.)

Commonwealth Navy Orders.

Navy Office, Melbourne,

8th February, 1944.

The following Orders, having been approved, are hereby promulgated for information and guidance, and necessary action.

By direction of the Naval Board,

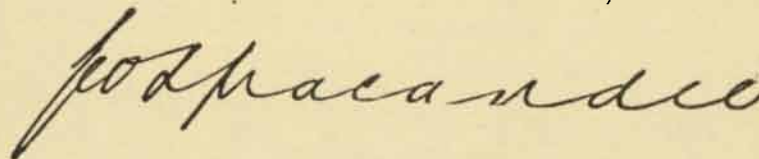

Secretary.

*The Rear-Admiral Commanding H.M.A. Squadron,
and Commanding Officers of H.M.A. Ships,
Officers in Charge of H.M.A. Naval
Establishments, and others concerned.*

TABLE OF CONTENTS.

No.	Subject.
73.	Naval Medical History of the War.
74.	Grant of Full and Modified "Qualified Officer" Status in the R.A.N.
75.	Eligibility of Telegraphist Ratings for Exemption in Certain Subjects of the Examinations for P.M.G. Certificates.
76.	Boxes, Ammunition, C.122 and C.199.
77.	Galley Shoes of Cooks—W.R.A.N.S.
78.	Books and Forms.
79.	Forwarding of C.W.I. Forms.
	C.1076/44.

73.

NAVAL MEDICAL HISTORY OF THE WAR.

It is desired to draw the attention of all R.A.N. Medical Officers to the fact that plans are being formulated for the production of a Medical History of the present war, including a Naval Medical Section.

2. The principal source of information will be Medical Journals and special reports or papers sent in by Naval Medical Officers. This history will constitute a permanent record, and its importance both as a record and for guidance in the future cannot be exaggerated. Medical Officers are requested to bear these facts in mind when compiling their Journals.

3. In addition, contributions of the following would be of great assistance and value:—narratives and comments on actions in which ships have taken part, with special reference to casualties and medical treatment; monographs or papers on subjects of medical importance from the Naval point of view; photographs of medical interest. All monographs, photos, &c., should be forwarded to the Director of Naval Medical Services, who will collect them and hand them over to the Editor of the Medical Statistical Section, who will be appointed shortly.

(527/201/882.)

74.

GRANT OF FULL AND MODIFIED "QUALIFIED OFFICER" STATUS IN THE R.A.N.

The provisions of A.F.O. 4916/43 are adopted in the R.A.N. for the purpose of grant of Full and Modified "Qualified Officer" status.

(568/201/913.)

75.

ELIGIBILITY OF TELEGRAPHIST RATINGS FOR EXEMPTION IN CERTAIN SUBJECTS OF THE EXAMINATIONS FOR P.M.G. CERTIFICATES.

With reference to Navy Order 107 of 1940—Request No. 87—the Postmaster-General's Department have notified that the concessions outlined therein will continue for the duration of the war and will then be reviewed.

2. The following summary is promulgated for information:—

SUMMARY.

Exemptions allowed Naval Personnel who desire to undertake Examination for the P.M.G. Certificate of Proficiency.

Naval Qualification.	Exemptions Allowed for P.M.G. Certificates.		Subjects Remaining After Exemptions Allowed.	
	First Class Commercial Operator's Certificate of Proficiency.	Second Class Commercial Operator's Certificate of Proficiency.	First Class Commercial Operator's Certificate of Proficiency.	Second Class Commercial Operator's Certificate of Proficiency.
W/T 2 (Higher Standard)	Sections E and F	Section A	Sections B, G, D, and H	Sections B, C, and D
W/T 3 (Higher Standard)	Nil	Section A	All subjects	Sections B, C, and D
W/T 2 (Lower Standard)	Nil	Section A	All subjects	Sections B, C, and D
W/T 3 (Lower Standard)	Nil	Nil	All subjects	All subjects

Section A.—A three-hour paper of seven questions on electrical and radio theory.

Section B.—A one-hour paper of six questions on Regulations.

Section C.—Two five-minute morse tests, one at 20 words per minute (plain language) and one other at 16 groups per minute (code), also a two and a half minute sending test of code at 16 groups per minute.

Section D.—Oral and Practical test on modern marine W/T installations and a traffic handling test.

Section E.—A two-hour paper of six questions on electricity and magnetism.

Section F.—A three-hour paper of seven questions on radio theory.

Section G.—Two five-minute receiving tests, one of 25 words per minute (plain language) and one of 20 groups per minute (code), also a two and a half minute sending test of code at 20 groups per minute.

Section H.—Oral and practical test on modern broadcast station equipment and resuscitation.

Notes.—(i) Copies of recent examination papers at a cost of 1s. per set, also a detailed syllabus for any certificate desired may be obtained on application to the Senior Radio Inspector, Wireless Branch, Postmaster-General's Department, in any State capital city of the Commonwealth.

(ii) Applications accompanied by the candidate's Wireless History sheet, certified by his Commanding Officer, should be forwarded to the Chief Inspector, Wireless Branch, Postmaster-General's Department, Treasury Gardens, Melbourne, C.2.

(437/202/79.)

76.

BOXES AMMUNITION C.222 AND C.199.

It has now been decided that Q.F. 4-in. XVI* gun ammunition issued to Armament Store Issuing Ships is to be packed in boxes C.222.

2. Paragraph 1 of Navy Order 2 of 1944 is to be amended accordingly.

(421/202/756.)

77.

GALLEY SHOES FOR COOKS—W.R.A.N.S.

The purchase of the wooden-soled clog type galley shoes for the loan use of W.R.A.N.S. cooks has been discontinued and future purchases will comprise leather-soled shoes specially constructed of stout design in sizes 2 to 8.

2. The wooden-soled shoes are to be issued and used until stocks are exhausted.

3. The price of the shoes for charge for losses by neglect, &c. (repayment issues are not to be made) is 17s. 6d. per pair and the necessary addition is to be made to the "Price List of Special Articles of Uniform and Clothing for personnel of the R.A.N. Women's Auxiliary Services."

(420/201/1096.)

78.

BOOKS AND FORMS.

First supplies of the under-mentioned publications have been distributed. Further supplies of B.R.797/43, B.R.853 and C.C.B.P.8 are being obtained to complete distribution:—

B.R.58.—International W/T Call Signs of United States Warships, Auxiliary Vessels, &c.

(571/202/1834.)

B.R.70/43.—Cumulative Supplement corrected to 30th June, 1943.

(A.F.O. 4882/43.)
(571/202/1654.)

B.R.150B, Amendments Nos. 1 and 2—Naval Manual of Aircraft Recognition—Part II.

(571/202/1646.)

B.R.172 (late O.U.5328).—Part I—Handbook of the Vickers 40 m.m. Automatic Gun Ordnance, Q.F., 2 pdr., Pom Pom, Mk. II*.

Part II—Notes for the Officer of Quarters.

B.R.172 (1).—Addendum No. 1 to B.R. 172.

(A.F.O. 3865/43.)
(571/202/1578.)

B.R.209/1935.—Drill for 2 pdr., Q.F., Mark II* Pom Pom Guns on H.A. Mark II Mountings.

(A.F.O. 3865/43.)
(571/202/904.)

B.R.232B.—Minor Landing Craft Signal Card, Signal Table I.

(A.F.O. 3006/43.)
(571/202/1791.)

Errata No. 11 to B.R.368 and Form D.129.—Establishment of Naval Stores for Sloops, Corvettes (Kittiwake types), &c., and Form D.129—List of Particulars.

(A.F.O. 533/43.)
(571/202/1548.)

B.R.767.—Notes for Medical Officers on Entry into the Royal Navy.

(A.F.O. 95/43.)
(571/202/1706.)

B.R.769.—A Guide to the Preservation of Life at Sea after Shipwreck.

(A.F.O. 659/43.)
(571/202/1778.)

Ministry of War Transport, Notice No. M.242.—Advice to those in Lifeboats and Rafts of Merchant Ships.

(571/202/1778.)

B.R.773.—Handbook for Echo-Sounding Set Type 760.

(A.F.O. 1622/43.)
(571/202/1758.)

B.R.785/43.—Handbook for 2 pdr. Mark VIII Gun on Marks VI A and V A Mountings.

(A.F.O. 1623/43.)
(571/202/1759.)

B.R.797/43 (late O.U.5532/40).—Handbook on Look-outs and Service Optical Instruments.

(A.F.O. 2208/43.)
(571/202/1743.)

B.R.821.—Preliminary Pamphlet for 4-in. Mark XIX Gun on Mark XXIII Mounting.

(A.F.O. 3349/43.)
(571/202/1794.)

B.R.825 (2) (late O.U.6384 D.G. Manual).—Operating Instructions for Vessels larger than Destroyers.

B.R.825 (3).—Operating Instructions for Destroyers and small Vessels using World-wide Settings.

B.R.825 (4).—Operating Instructions for Locally Based Minor War Vessels.

(A.F.O. 4237/43.)
(571/202/1833.)

B.R.826.—Drill for the Fuzekeeping Clock and Fire Control Box.

(A.F.O. 2899/43.)
(571/202/1790.)

B.R.828/43.—Medical War Research Council War Memorandum No. 10—"Sulphonamide Chemotherapy."

(A.F.O. 2077/43.)
(571/202/1745.)

B.R.843 (late C.B.3065).—Handbook for the 2-in. Rocket, Mark V, F.A.M. Mounting/1941.

(571/202/1819.)

B.R.844 (late C.B.4154).—Preliminary Handbook for the 2-in. Rocket, Mark IV, Gymbal Mounting/1941.

(571/202/1818.)

B.R.853.—Procedure for Oiling at Sea by the Buoyant Hose Method.

(A.F.O. 3641/43.)
(571/202/1805.)

O.U.6090L.—Diagram G.L. XXII A/43.

(571/203/2497.)

List of Errata No. 2.—Establishment of Naval Stores for Fair-mile Craft.

(A.F.O. 3353/43.)
(603/246/2427.)

A.T.3023.—Theory Notes for Radio Mechanics.

(571/201/4008.)

C.C.B.P.8.—Combined Panel System.

(571/201/4004.)

Artillery Training, Volume II, Pamphlet No. 17—Deployment of a Light A.A. Regiment, 1943.

(571/201/3995.)

"Spoken Japanese Simplified." (Peter V. Russo.)

(571/201/3987.)

Anti-Aircraft Procedure Instructions (Aust.) No. 11 (Amended).

Anti-Aircraft Procedure Instructions (Aust.) Amendments (No. 1).

(571/201/3921.)

Army Training Memorandum (War) (Australia) No. 25.

(546/201/443.)

Civil Defence Handbook No. 5—"The Operation and Maintenance of Trailer Pumps."

(449/203/327.)

Table X—Control Signals to Air Force Code (A.P.1927).

(571/201/3924.)

79.

FORWARDING OF C.W.1 FORMS.

Attention is drawn to Navy Order 103 of 1943, paragraph 6, concerning the forwarding of C.W. Form 1A. Copies of this Form are frequently sent to Secretary, Naval Board.

2. Forms should be prepared in duplicate, original being retained and duplicate forwarded direct to the Naval Officer-in-Charge, Flinders Naval Depot.

(432/205/5719.)

RESTRICTED.(FOR OFFICIAL USE ONLY.)

Commonwealth Navy Orders.

Navy Office, Melbourne,
15th February, 1944

The following Orders, having been approved, are hereby promulgated for information and guidance and necessary action.

By direction of the Naval Board,

J. P. Macandee
Secretary.

*The Rear-Admiral Commanding H.M.A. Squadron,
and Commanding Officers of H.M.A. Ships.
Officers in Charge of H.M.A. Naval
Establishments, and others concerned.*

TABLE OF CONTENTS.

No.	Subject.
80.	Revocation of Direction under the Wireless Stations Control Order.
81.	Educational Test I—September, 1943—Results.
82.	Ordnance and Electrical Mechanic Branches.
83.	Offences committed by Ratings on Passage to and before joining H.M.A.S. "Melville."
84.	Radar Branch Advancement.
85.	Commonwealth Savings Bank Agencies—Commission.
86.	Small Arms—Revolvers—Accidents.
87.	A.F.O. 5584/43—Tetanus Prophylaxis.
88.	A.M.S. Vessels—P.A.C. Rockets—Possible Fouling of Aerial Arrays.
89.	Maintenance of Cordite Records on board H.M.A. Ships.
90.	Cordite Landing.
91.	Combustion Cones for Boilers Manufactured from Heat Resisting Steel—To be dealt with as Permanent Naval Stores.
92.	Canvas Hose Tubing—Reduction of Demands and Rules for Prolonging Life.
93.	D.E.M.S. Gunnery Ratings—Badges.
94.	Form O.426—History Sheets for Depth Charge Pistols.
95.	Cartridges S.A., Ball 9 mm. of D I L Manufacture—Restriction.
96.	Corrigendum.

C.1263/44.

TOONE

2425-5

24857

80.

The following revocation of Direction under the Wireless Stations Control Order is promulgated for information:—

(*Commonwealth Gazette*, No. 23, dated 2nd February, 1944.)

COMMONWEALTH OF AUSTRALIA.

NATIONAL SECURITY (GENERAL) REGULATIONS.

REVOCATION OF DIRECTION UNDER THE WIRELESS STATIONS CONTROL ORDER.

The Direction under the Wireless Stations Control Order, made by the Chief of the Naval Staff, dated the twelfth day of April, One thousand nine hundred and forty-three, is hereby revoked.

Dated this 28th day of January, 1944.

G. C. C. ROYLE,
Chief of the Naval Staff.

81.

EDUCATIONAL TEST I: SEPTEMBER, 1943.—RESULTS.

The following ratings passed Educational Test I held on 28th September, 1943:—

Name.	Rating.	Official Number.
<i>H.M.A.S. Australia.</i>		
Bohme, Ronald A.	Stoker	24552
Ising, Howard A.	Bandsman	24631
Thompson, Eric S.	"	23066
<i>H.M.A.S. Broome.</i>		
Smith, Norman T.	Stoker	W/2516
<i>H.M.A.S. Cerberus.</i>		
Chapman, Ronald J.	Stoker, 3rd Class	S/8870
Clark, Donald N.	Stoker, 2nd Class	W/2790
Cousins, Leicester K.	"	F/5131
Duigan, Paul J.	"	W/2918
Feazey, Percival	Stoker, 3rd Class	F/5144
Gaskin, Gregory C.	"	B/4785
Kent, Walter J.	"	W/2856
Lane, Mervyn G.	"	B/4810
Lewis, Leonard J.	"	S/8791
McLeod, Donald	"	B/4771
McNab, Colin I.	"	B/4815
Patterson, Deveron R.	Stoker, 2nd Class	PA/4273
Reid, Thomas M.	Stoker, 3rd Class	PA/3443
Richards, Cyril J.	Stoker, 2nd Class	H/2621
Russell, Charles H.	"	S/8721
Schafer, John A.	"	W/2852
Thompson, Arthur C.	Stoker, 3rd Class	S/8783
Watson, Noel F.	"	S/8880

EDUCATIONAL TEST I: SEPTEMBER, 1943.—RESULTS—*continued.*

Name.	Rating.	Official Number.
<i>H.M.A.S. Colac.</i>		
Edgar, Robert W.	Stoker	S/5660
Fielding, Keith P.	Ordinary Seaman	H/2369
Milliss, Francis O.	Stoker, Petty Officer	22964
<i>H.M.A.S. Gladstone.</i>		
Mackenzie, Alan M.	Stoker	B/4715
Mashford, James G.	S/Assistant	PA/3104
Morrison, Kenneth M.	Stoker	PA/2323
Roberts, Donald B.	"	S/6914
<i>H.M.A.S. Leeuwin.</i>		
Brown, Edward	Writer	F/4088
<i>H.M.A.S. Magnetic.</i>		
Macartney, David E.	Stoker, 2nd Class	B/4512
<i>H.M.A.S. Manoora.</i>		
Reynolds, Leslie M.	A/Able Seaman	S/6713
<i>H.M.A.S. Mary Cam.</i>		
Knight, Alexander	Steward	PM/3726
Press, Frank E.	Ordinary Seaman	PA/3124
<i>H.M.A.S. Melville.</i>		
Baker, Frederick G.	Leading Std.	21550
<i>H.M.A.S. Moresby.</i>		
Ambrose, Leslie J.	Prob/Sy. Assistant	S/8661
Doyle, John K.	Writer	S/5357
Jones, Victor J.	Stoker, 2nd Class	S/7988
Lloyd, Frederick H.	"	S/8557
Munro, Robert J.	Leading S.B.A.	PM/1750
O'Connell, John H.	Ordinary Seaman	S/7420
<i>H.M.A.S. Orara.</i>		
Berry, John W.	Stoker	24871
Cowmeadow, Ronald	Stoker, 2nd Class	W/1846
Cunning, Keith R. J.	"	W/1512
Hopkins, John C.	Able Seaman	23377
Minton, Lawrence A.	"	W/1648
McCallum, Jack M.	"	W/1545
McDonald, William S.	"	W/1647
Roe, William A.	"	22772
Shipway, Stanley W.	Stoker, 2nd Class	PA/3392
Stirling, Kenneth D.	"	W/1586

EDUCATIONAL TEST I: SEPTEMBER, 1943.—RESULTS—continued.

Name.	Rating.	Official Number.
<i>H.M.A.S. Platypus.</i>		
Auld, Colin H.	Leading Stoker	23004
<i>H.M.A.S. Westralia.</i>		
Matheson, John D.	Able Seaman	S/6751
Opie, Ronald L.	Ordinary Seaman	PA/3666
Pötter, Edward T.	Able Seaman	F/2315
The following qualified educationally for Acting Leading Stoker:—		
<i>H.M.A.S. Cerberus.</i>		
Batger, Keith T.	Stoker, 2nd Class	S/8076
Campbell, Bruce M.	" "	S/8863
Chadwick, Ronald C.	" "	W/2910
Cooley, Leonard K.	Stoker, 3rd Class	S/8734
Edwards, Francis K.	Stoker, 2nd Class	S/8868
Foster, William J.	Stoker, 3rd Class	S/8897
Gardner, Ian	Stoker, 2nd Class	B/4748
Gentles, Albert H. G.	" "	26803
Higate, George F.	" "	F/4842
Morgan, John H.	Stoker, 3rd Class	B/4731
O'Brien, Joseph F.	Stoker, 2nd Class	S/8030
Stevens, John S.	" "	F/5133
<i>H.M.A.S. Colac.</i>		
Newton, Mervyn R.	Stoker, 2nd Class	B/4412
<i>H.M.A.S. Moresby.</i>		
Davey, Kevin J.	Stoker, 2nd Class	PA/3209
Halley, Ivan S.	" "	B/3464
New, Roy H.	" "	B/4155
<i>H.M.A.S. Orara.</i>		
Bailey, Ralph T.	Stoker, 2nd Class	W/2588
Hough, Cyril B.	Stoker	W/1694

(465/205/661.)

(This Order will be reprinted for posting on Notice Boards.)

82.

ORDNANCE AND ELECTRICAL MECHANIC BRANCHES.

It has been decided to introduce the new branch of Ordnance and Electrical Mechanics.

2. Seaman ratings with the non-substantive rate of Q.O. and Leading Wiremen and Wiremen are eligible to apply for transfer to this branch, provided they have completed 12 months' sea service.

3. The training of ratings selected for transfer will be commenced as early as practicable. Names of recommended volunteers should be forwarded to the Naval Officer-in-Charge, Flinders Naval Depot, giving details of mechanical knowledge or previous experience, if any.

4. Full details of rates of pay, which are higher than Artisan rates but lower than Artificer rates, conditions of service and advancement will be promulgated later.

(349/3/167.)

(This Order will be reprinted for posting on Notice Boards.)

83.

OFFENCES COMMITTED BY RATINGS ON PASSAGE TO AND BEFORE JOINING H.M.A.S. "MELVILLE."

It has been observed that offences committed by ratings on passage to and before joining H.M.A.S. *Melville* are sometimes stood over to be dealt with in that establishment, with consequent delays in the awarding of punishment. Offences for which detention is normally the correct punishment are, as a consequence, frequently further delayed by having to await vacancies in the Army Detention Quarters in Northern Territory.

2. In future when such offences are committed *en route* to Darwin, e.g., at Brisbane, Townsville, or Adelaide, they are to be investigated and dealt with in the establishment in which the rating is temporarily accommodated whilst awaiting onward passage.

(452/201/1470.)

84.

RADAR BRANCH ADVANCEMENT.

The following amendment is to be made to Navy Order 519 of 1943, paragraph 4 (d) (iii), line 10—

Delete word "when" and insert "until".

(568/202/906.)

85.

COMMONWEALTH SAVINGS BANK AGENCIES—COMMISSION.

With reference to Naval Account Regulations and Instructions, Article 140, the commission payable by the Commonwealth Savings Bank to R.A.N. Accountant Officers appointed as Agents of the Bank will be limited to a maximum of £200 for each commission year ending February. This limitation will be applied in respect of the year ending 29th February, 1944. Any adjustments necessary will be made in connexion with the next issue of Finance Authorities for payment of commission.

2. Commencing 1st March, 1944, the full amount of commission credited by the Bank to the end of each quarter will be authorized for payment from Navy Office, subject only to the limitation of £200 as the total amount which may be paid for each commission year.

(418/202/653.)

86.

SMALL ARMS—REVOLVERS—ACCIDENTS.

Attention is drawn to A.F.O. 3813/43.

2. Whenever it is necessary to arm a sentry or quartermaster with a loaded revolver, reliefs are to be posted by a responsible Officer or Petty Officer, who is to inspect the revolver on each occasion and also satisfy himself that the rating concerned has received adequate instruction in its use.

(432/221/3275.)

87.

A.F.O. 5584/43—TETANUS PROPHYLAXIS.

The attention of all Medical Officers is drawn to A.F.O. 5584 of 1943, the provisions of which are to be strictly carried out in the R.A.N.

2. Supply of Tetanus Antitoxin (Code Word DARK) is made in 1 c.c. ampoules and not in 10 c.c. containers as in the R.N.

3. Supply should be obtained from Medical Store, or, in urgent cases, from the Commonwealth Serum Laboratories.

(612/213/2584.)

88.

A.M.S. VESSELS: P.A.C. ROCKETS—POSSIBLE FOULING OF AERIAL ARRAYS

Owing to the possibility that P.A.C. rockets may foul radar and wireless aerials, all these rockets are to be landed by A.M.S. Vessels.

2. P.A.C. projectors are to be retained for use with snowflakes.

3. Ships' Warrants are to be amended.

(603/267/1447.)

89.

MAINTENANCE OF CORDITE RECORDS ON BOARD H.M.A. SHIPS.

Reference is made to Admiralty Fleet Order 4957/43 respecting the maintenance of modified cordite records on board H.M. Ships during the war.

2. It has been decided that the provisions of this Admiralty Fleet Order are to apply in the Royal Australian Navy.

(471/202/1399.)

90.

CORDITE LANDING.

All cartridges containing cordite of the following lots on board H.M.A. Ships and Auxiliary Vessels are to be landed before the 29th February, 1944:—

<i>Lot No.</i>			<i>Size.</i>
R.N. 2797	M.C.T. 15—13
R.N. 2797 Y	M.C.T. 15—13
R.N. 2813	M.C.T. 15—13
R.N. 2819	M.C.T. 15—13

2. At Depots, any cartridges or bulk cordite of the above lots so received, together with any in store, may be retained for a further period of six months from the due date for withdrawal.

3. *Care is to be taken that any cartridges of the lots shown in paragraph 1, but marked R.U., are also landed and similarly dealt with.*

(471/202/1898.)

91.

COMBUSTION CONES FOR BOILERS MANUFACTURED FROM HEAT-RESISTING STEEL—TO BE DEALT WITH AS PERMANENT NAVAL STORES.

Combustion Cones for Boilers and Palm Supports manufactured from heat-resisting steel, which are at present Engineers' Consumable Special Stores, are to be transferred to the List of Permanent Naval Stores in all H.M.A. Ships, and in future when defective beyond repair by ship's staff, they should be returned to store on the appropriate Survey Form A.S.331 for reconditioning or renewal as necessary.

(603/247/1679.)

92.

CANVAS HOSE TUBING—REDUCTION OF DEMANDS AND RULES FOR PROLONGING LIFE.

Attention is drawn to Admiralty Fleet Order No. 982/43 relative to the acute position existing in regard to the supply of Canvas Hose Tubing, and to the action which is to be taken for the conservation of supplies thereof.

2. Similar conditions exist in Australia, and it is essential that the instructions contained in the A.F.O. quoted above be closely observed by all concerned.

(612/229/188.)

93.

D.E.M.S. GUNNERY RATINGS—BADGES.

Action has been taken to procure stocks of the badges approved for wear by D.E.M.S. ratings qualified as Acting Gunlayers and Acting Seamen-Gunners, *vide* A.F.O. 3210/1943.

2. Requirements are to be demanded from Royal Edward Victualling Yard, Sydney, for supply as soon as stocks are available.

3. The issuing prices of the badges are as follows:—

	<i>s.</i>	<i>d.</i>	
Patt. 220A Acting Gunlayer D.E.M.S.	1	0	each
„ 221A Acting Seaman-Gunner D.E.M.S.	0	10	„
„ 222A Letters D.E.M.S.	0	4	„

4. The necessary addition is to be made to page 12 of the “Official Memorandum—Prices of Clothing, &c., maintained for Issue on Repayment to Ships’ Companies” dated 1st May, 1943, under a new sub-heading of “D.E.M.S. ratings.”

(416/201/1000.)

94.

FORM 0.426—HISTORY SHEETS FOR DEPTH CHARGE PISTOLS.

In future, demands for Forms 0.426, “History Sheet for Depth Charge Pistols,” are to be forwarded to the Superintending Naval Store Officer, Sydney.

(480/201/3229.)

95.

CARTRIDGES S.A. BALL, 9 M.M. OF D I L MANUFACTURE—RESTRICTION.

Information has been received that Cartridges S.A., ball, 9 m.m. of D I L manufacture are unserviceable, and must not be fired.

2. It is not certain whether cartridges S.A., ball, 9 m.m. of D I L manufacture are of English or American origin.

3. Any cartridges of this manufacture on board ships are to be returned to the nearest Naval Armament Depot and other cartridges drawn in lieu.

4. Naval Armament Depots are to set aside any of these cartridges in store, reporting to Navy Office the quantities involved.

(408/206/1375.)

96.

CORRIGENDUM.

With reference to Navy Order 24 of 1944, “Vice Admiral A. S. Carpenter, U.S.N.” is to be amended to read “Vice Admiral A. S. Carpender, U.S.N.”.

(443/202/196.)

By Authority: H. E. DAW, Government Printer, Melbourne.

RESTRICTED.(FOR OFFICIAL USE ONLY.)**Commonwealth Navy Orders.**

Navy Office, Melbourne,

22nd February, 1944.

The following Orders, having been approved, are hereby promulgated for information and guidance, and necessary action.

By direction of the Naval Board,

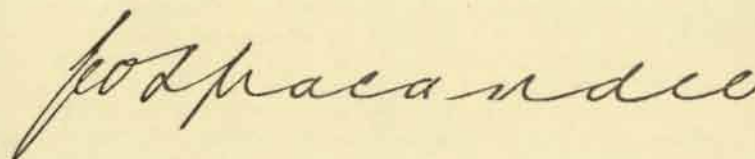

Secretary.

*The Rear-Admiral Commanding H.M.A. Squadron,
and Commanding Officers of H.M.A. Ships,
Officers in Charge of H.M.A. Naval
Establishments, and others concerned.*

TABLE OF CONTENTS.

No.	Subject.
97.	Rail Accommodation on West-East Express from Adelaide.
98.	Naval Censorship.
99.	Gas Cylinders—Return of Contractors’ Cylinders on Issue from H.M.A. Naval Establishments, Garden Island.
100.	Detonators—Mark I—Withdrawal.
101.	Fresh Provisions at Melbourne and Sydney.
102.	Books and Forms.
103.	Corrigenda.

C.1650/44.

97.

RAIL ACCOMMODATION ON WEST-EAST EXPRESS FROM ADELAIDE.

Owing to the difficulties in obtaining accommodation on trains from Adelaide to the Eastern States on Saturdays, it is desired that when Commanding Officers are granting leave to South Australian personnel, periods should, whenever practicable, be arranged to permit them to make return journey *ex-Adelaide* on days other than Saturday.

(632/202/1083.)

98.

NAVAL CENSORSHIP.

Paragraph 13 of Navy Order 23 of 1944—Naval Censorship—is cancelled, and the following paragraph is substituted in its stead:—

“13. In vessels carrying a normal complement of 100 or less, ship-board censorship will not ordinarily be imposed, but all mail is to be handed or forwarded by safe-hand means to the Naval Officer-in-Charge nearest to the port at which the mails are landed, who is to detail an officer to perform the duties of censor. In cases where it is not practicable for mail to be handed or forwarded by safe-hand means to a Naval Officer-in-Charge for censoring or where, in the opinion of the Naval Officer-in-Charge at the port at which the mails would normally be landed, circumstances render it impracticable that censorship of such mails be carried out on shore, censorship is to be carried out in the ship.”

(1835/2/601.)

99.

GAS CYLINDERS—RETURN OF CONTRACTORS' CYLINDERS ON ISSUE FROM H.M.A. NAVAL ESTABLISHMENTS, GARDEN ISLAND.

The following gas cylinders, which are the property of the Commonwealth Oxygen and Acetylene Company Pty. Ltd., have been on issue to H.M.A. Ships and Establishments from H.M.A. Naval Yard, Garden Island, for lengthy periods. Monthly charges are made in respect of these cylinders, and as it is anticipated that cylinders now

being purchased by the Department will be adequate for requirements, it is desired to arrange return of Contractors' cylinders as early as practicable:—

Cylinder No.	Type.	Cylinder No.	Type.
T478	Coal Gas.	50068	Acetylene.
AA270	" "	11564	" "
AA032	" "	1979	" "
10789	" "	13471	" "
T247	Oxygen.	12448	" "
T186	" "	12267	" "
T594	" "	A2414	" "
T494	" "	70428	" "
T557	" "	54812	" "
T485	" "	53169	" "
T502	" "	51997	" "
T582	" "	A2539	" "
T117	" "	17042	" "
T251	" "	A2778	" "
T380	" "	54735	" "
T295	" "	53185	" "
T286	" "	50086	" "
T503	" "	50236	" "
T451	" "	11584	" "
T144	" "	70600	" "
T398	" "	53270	" "
T260	" "	70279	" "
T565	" "	11345	" "
T552	" "	54789	" "
T133	" "	12437	" "
A17065	Acetylene.	12870	" "
70281	" "	54757	" "
A2461	" "		" "

2. A careful search for these cylinders is to be made in all H.M.A. Ships and Establishments, and arrangements made for them to be landed at the nearest Storing Yard for return to the Superintending Naval Store Officer, Sydney, at the first opportunity after they have been emptied of gas. Particulars of despatch of the cylinders should be forwarded direct to the Superintending Naval Store Officer, Sydney.

3. In view of the length of time that the cylinders have been on issue, a check of Store Ledgers should also be made to ascertain whether any of them have already been returned to the owners at a port other than Sydney, or have been otherwise disposed of. Particulars of any such returns, &c., should be forwarded direct to the Superintending Naval Store Officer, Sydney.

4. A return is to be forwarded to Navy Office by all Ships indicating any of the above cylinders which, on 7th February, were held on board or for which supply or advance notes indicating that cylinders were in transit had been received. Particulars of cylinders returned direct to Contractors should also be included. "NIL" returns are required.

(669/201/1052.)

100.

DETONATORS NO. 25 MK. I—WITHDRAWAL.

With reference to Navy Order 98 of 1943, stocks of detonators No. 25 Mk. II are now becoming available. If not already done, H.M.A. Ships are to demand replacements of Mk. II detonators from the nearest Naval Armament Depot, Mk. I detonators being landed on receipt.

2. Naval Officers-in-Charge of ports north of Brisbane are to demand from the Armament Supply Officer, R.A.N. Armament Depot, Spectacle Island, Sydney, stocks of detonators No. 25 Mk. II required to replace detonators No. 25 Mk. I, which are to be returned to Sydney on receipt of the Mk. II detonators.

3. Detonators No. 25 Mk. I are considered suitable for other areas, especially for Flinders Naval Depot and H.M.A.S. *Assault* for instructional purposes, &c., and are to be given priority in expenditure where possible.

4. For R.M.S. purposes in all areas, detonators No. 25 Mk. II only are to be used and detonators No. 25 Mk. I held for this purpose are to be replaced by Mk. II detonators.

(471/201/1290.)

101.

FRESH PROVISIONS AT MELBOURNE AND SYDNEY.

Appended are details of Contract Rates for supply of certain items of fresh provisions at Melbourne and Sydney during the period commencing 1st January, 1944.—

A. MELBOURNE.*Vegetables and Fruit.*

Period—1st January to 31st March, 1944.

Contractor—Pirrie Bros., 136-138 Exhibition-street, Melbourne, C.1.

Potatoes—Market Rates, plus 2½ per cent.

Onions—Market Rates, plus 1 per cent.

Contractor—Bailey Bros., Queen's Wharf-road, Melbourne, C.1.

Turnips, white—1½d. lb.

Turnips, swede—2d. lb.

Parsnips—2d. lb.

Marrows—1½d. lb.

Pumpkins—2d. lb.

Cabbages—2d. lb.

Carrots—2½d. lb.

Radishes—4d. lb.

Lettuce—4d. lb.

Beetroot—2d. lb.

Charge for bags, other than potato and onion, if not returned, 1s. each.

Dairy Produce.

Period—1st January to 31st December, 1944.

Butter and Cheese.

Contractor—Gippsland and Northern Co-op. Ltd., 492 Flinders-lane, Melbourne, C.1.

(*Ships and Naval Establishments except at Westernport.*)

Butter—in prints (cost of boxes to be included) "Sunny South" brand.—At Market Rates for bulk, plus ½d. per lb. for prints, then less 2½ per cent.

Cheese—Semi-matured, small.—At Market Rates for new cheese, plus 1d. per lb. for semi-matured—net.

Semi-matured, large.—At Market Rates for new cheese, plus 1d. per lb. for semi-matured—net.

Choice matured, mellow, small (loaf).—At Market Rates for new cheese, plus 1½d. per lb. for matured—net.

Choice matured, mellow, large (loaf).—At Market Rates for new cheese, plus 1½d. per lb. for matured—net.

The brands of cheese are "Sunny South" and "Loorana."

The prices quoted include delivery f.o.r. Melbourne, f.o.b. Victoria Dock. Cartage to Port Melbourne and Williamstown extra at cost.

An allowance of 4s. per dozen will be made on all butter and cheese cases returned in good order and condition.

Contractor—Holdenson and Neilson Fresh Food Pty. Ltd., 525 Flinders-street, Melbourne, C.1.

(*For Westernport only.*)

Butter—in prints (cost of boxes to be included), "Iceberg" brand.—Market Rates, minus 3 per cent.

Cheese—Semi-matured, small—Market Rates, plus ½d. per lb.

Semi-matured, large.—Market Rates, plus ½d. per lb.

Choice matured, mellow, large (loaf).—Market Rates, plus 1½d. per lb.

Choice matured, mellow, small (loaf).—Market Rates, plus 1½d. per lb.

Market Rates shall be the wholesale rates as quoted in the *Argus* newspaper on Friday of each week, such prices to govern supplies from the Saturday up to and including the Friday next following.

Bacon.

Contractor—Gippsland Co-op. Bacon Curing Co. Ltd., P.O. Box 42, Dandenong.

Bacon Sides—Weights 40 to 65 lb. per side "Dandy" brand.—

At 1s. 3d. per lb. (to nearest lowest ¼ lb.) (subject to adjustment from time to time, according to prices ruling.)

Eggs.

Contractor—Egg and Egg Pulp Marketing Board, 528 Collins-street, Melbourne, C.1.

Eggs, fresh.—At Market Rates net, plus ½d. per dozen, to cover cartage to Naval Depots at Melbourne, Williamstown, or to rail Melbourne.

Cases and Fillers 8s. each rebateable on return as follows:—

Cases complete with fillers and lids—8s. each.

Cases minus fillers and lids—4s. 10d. each.

Cases with fillers minus lids—6s. 6d. each.

Cases minus fillers—6s. 4d. each.

Period—1st January to 31st December, 1944.

Market Rates for Eggs shall be the wholesale market rate as published in the *Argus* newspaper on Monday of each week, such prices to govern supplies from the Monday up to and including the Sunday next following.

B. SYDNEY.

Meat.

Period—1st January to 30th June, 1944.

Contractor—Thomas Playfair Pty. Ltd., Argyle-street, Sydney.

Item; Fresh or Frozen.

Beef Fores—4 $\frac{3}{4}$ d. lb.
 Beef Hinds—8 $\frac{3}{4}$ d. lb.
 Beef Ribs, Boned and Rolled—8d. lb.
 Beef Topsides—9 $\frac{1}{2}$ d. lb.
 Beef Thick Flank—6d. lb.
 Beef Corned Rounds—9 $\frac{1}{2}$ d. lb.
 Beef Minced Steak—6d. lb.
 Veal Carcasses (1st quality only)—7 $\frac{1}{2}$ d. lb.
 Veal Sides, bone in—7 $\frac{1}{2}$ d. lb.
 Veal Hinds, bone in—9 $\frac{3}{4}$ d. lb.
 Veal Fores, bone in—5 $\frac{1}{2}$ d. lb.
 Veal Sides, boneless—9d. lb.
 Veal Hinds, boneless—11 $\frac{3}{4}$ d. lb.
 Veal Fores, boneless—7d. lb.
 Veal Legs, boneless—11d. lb.
 Mutton Sides—4 $\frac{3}{4}$ d. lb.
 Mutton Chops—8d. lb.
 Mutton Legs—6d. lb.
 Lamb Carcasses—8 $\frac{1}{2}$ d. lb.
 Pork Sides—11 $\frac{3}{4}$ d. lb.
 Pork Chops—1s. 3d. lb.
 Pork Corned—11 $\frac{1}{2}$ d. lb.
 Rabbits—2s. 0 $\frac{1}{2}$ d. pair.
 Sausages, Pork—10d. lb.
 Sausages, Mixed—7d. lb.
 Sausages, Luncheon—8 $\frac{1}{2}$ d. lb.
 Brawn—6d. lb.
 Kidneys, Ox—1s. 1d. lb.
 Kidneys, Sheep—2 $\frac{1}{2}$ d. each.
 Sheep's Fries—7d. lb.
 Tripe—5 $\frac{1}{2}$ d. lb.
 Dripping—4 $\frac{3}{4}$ d. lb.
 Saveloys—1s. 1d. dozen.
 Frankfurts—11d. lb.
 Ice—2s. 6d. cwt.

Less 1 per cent.—14 days.

Milk and Cream.

Period—1st January to 31st December, 1944.

Contractor—New South Wales Fresh Food and Ice Co. Ltd., Harbour-street, Sydney.

Pasteurized Milk—1s. 11 $\frac{1}{2}$ d. per gallon net.

Fresh Cream, if required (hospital patients only)—15s. per gallon net (bulk).

Vegetables.

Period—November, December, 1943, and January, 1944.

Contractor—C. G. Kellaway and Sons Pty. Ltd., 22 Quay-street, Sydney.

Item.	November.	December.	January.
	<i>s. d.</i>	<i>s. d.</i>	<i>s. d.</i>
Beetroot	20 0 bush.	23 0 cwt.	16 0 cwt.
Cabbages	21 0 cwt.	16 0 "	14 0 "
Carrots	25 0 "	25 0 "	25 0 "
Lettuce	57 0 "	37 4 "	30 11 "
Marrows	30 0 "	14 0 "	12 0 "
Onions, spring	56 0 "	37 4 "	5 0 doz. bchs
Parsley	0 10 bch.	0 9 bch.	1 0 bch.
Parasnips	28 0 cwt.	28 0 cwt.	25 0 cwt.
Pumpkin	12s. to 22s. 6d. cwt.	19 0 "	11 0 "
Radishes	0 3 $\frac{1}{2}$ bch.	0 3 bch.	0 3 bch.
Turnips, swede	12 0 cwt.	10 0 cwt.	10 0 cwt.
Turnips, white	12 0 "	10 0 "	10 0 "

Bags to be charged at 1s. each if not returned.

Dairy Produce.

Period—Butter and Cheese—1st January, to 31st December, 1944.

Eggs—1st January to 4th July, 1944.

Contractor—Foley Bros. Pty. Ltd., Sussex-street, Sydney.

Butter.—Market Rates net, delivered—"Foley" brand (including prints and boxes).

Contractor—Producers' Co-op. Distributing Society Ltd., Quay and Valentine Streets, Sydney.

Cheese—Market Rates net, delivered—"First Grade Australian" brand (loaf and/or large).

Contractor—Egg Marketing Board, Wattle-crescent, Pyrmont.

Fresh Eggs—Market Rates net.—Plus case maintenance charge 6d. per 30 dozen, 3d. per 15 dozen. Delivery *ex* Board's Floor, Pyrmont.

or alternatively

Fresh Eggs—Market Rates net.—Plus case maintenance charge 6d. per 30 dozen, 3d. per 15 dozen. Plus delivery charges.

In addition to the above charges, cases will be charged at 5s. each 30 dozen, 2s. 6d. each 15 dozen, such deposit to be credited in full on return of cases, lids, and fillers in good order and condition.

(668/201/2754.)

102.

BOOKS AND FORMS.

The under-mentioned form has been revised, and supplies will be issued, on demand, by the Superintending Naval Store Officer, Sydney, when stock of the existing form is exhausted:—

A.S.37 "Account of Money Deposited with Accountant Officer for Custody only."

(480/202/4482.)

2. The under-mentioned form has been adopted for use in the R.A.N., and first supply will be issued without demand:—

S.342A "Records of Defects Developed and made good in Small Craft."

(A.F.O. 221/43.)

(480/202/4511.)

3. The under-mentioned form has been introduced for use in the R.A.N. in lieu of the corresponding Admiralty Form. Supply will be issued, on demand, when stock of the existing form is exhausted:—

D.E.M.S.2 (R.A.N.)—"Return of Inspection of Ships Equipped as Fast Liners or D.E.M.S."

(480/201/3214.)

4. The under-mentioned form has been introduced for use in the R.A.N., and supplies will be issued, on demand, by the Superintending Naval Store Officer, Sydney:—

A.S.1332 "Advice and Receipt Note for use when Despatching Service Certificates, Transfer Lists, and other forms for which an acknowledgment is required."

(480/202/4496.)

5. The under-mentioned form has been introduced for use in connexion with the purchase of all items controlled by the Director of Machine Tools and Gauges. First supply will be issued, without demand, to H.M.A. Naval Establishments concerned by the Superintending Naval Store Officer, Sydney:—

Tool Demand.

(480/201/3296.)

6. The under-mentioned form has been introduced for use in H.M.A. Ships fitted with four boilers. Supply will be effected, on demand, by the Superintending Naval Store Officer, Sydney:—

A.S.467A "Record of Daily Treatment of Boilers (Fly Sheet to Engine Room Register)."

A.S.467z (late A.S.467A) "Tube History Sheet." The existing Form A.S.467A is to be retained in use and renumbered A.S.467z.

(480/202/4495.)

7. The under-mentioned form will not be reprinted during the term of hostilities:—

A.S.583 "Seaman Branch—Choice of Non-substantive Branch."

(480/202/4417.)

8. The latest Admiralty revision of the under-mentioned form has been introduced for use in the Royal Australian Navy. First supply will be issued, without demand, by the Superintending Naval Store Officer, Sydney:—

S.1203 "Report of Attack on U Boat."

(C.A.F.O. 1342/43.)

(480/202/4540.)

9. First supply of the under-mentioned form has been distributed by the Superintending Naval Store Officer, Sydney:—

S.1555 "Drawings of British and American Landing Craft."

(480/202/4530.)

10. The under-mentioned form has been revised. Supply will be effected, on demand, by the Superintending Naval Store Officer, Sydney, when stock of existing form is exhausted:—

A.D.448 Report of Inspection.

(480/201/3253.)

103.

CORRIGENDA.

(a) For "1 No. fatigue net" in Navy Order 55 of 1944—"Royal Australian Naval Women's Services—Uniform and Clothing—Authorized Kit"—read "1 No. fatigue hat."

(b) For "2,200 volts" in Navy Order 66 of 1944—"Loss of Ventilating Fan"—read "220 volts."

RECEIVED
3 MAR P.M.
Army Registry

(FOR OFFICIAL USE ONLY.)

Commonwealth Navy Orders.

Navy Office, Melbourne,

29th February, 1944.

The following Orders, having been approved, are hereby promulgated for information and guidance and necessary action.

By direction of the Naval Board,

Godfray
Secretary.

*The Rear-Admiral Commanding H.M.A. Squadron,
and Commanding Officers of H.M.A. Ships,
Officers in Charge of H.M.A. Naval
Establishments, and others concerned.*

TABLE OF CONTENTS.

No.	Subject.
104.	Examination of Sick Berth Staff—November, 1943—Results.
105.	Naval Board of Administration—Business Member.
106.	Acting Petty Officers—Irregular Wearing of Class III Uniform.
107.	Shuttle Valves of Reciprocating Pumps—Heat Treatment.
108.	Accounting for Machinery, Machine Tools, &c., Supplied for Naval Workshops.
109.	Lubricating Oils—H.M.A. Ships—"Kybra," "Wilcannia" and "Reserve."
110.	Repainting of A.M.S. Vessels.
111.	Annual Inspection of Explosives ex H.M.A. Ships.
112.	Loan Issue of Brown Dungaree Combination Suits to Officers.
113.	Use of Soda Ash in Lieu of Soda Crystals for Cleansing Purposes.
114.	Canvas Flag Wallet for A.M.S. Vessels.
115.	Economy in Consumption of Butter.
116.	Corrigendum.

EXAMINATION OF SICK BERTH STAFF—NOVEMBER. 1943—RESULTS.

The results obtained by candidates who passed in the examination for advancement in the Sick Berth Branch, held on 23rd November, 1943, are as given hereunder:—

Examination Number.	Name.	Present Rating.	O.N.	Percentage of Marks obtained at Examination.				Approximate Average Percentage for (a) Written, and (b) Oral and Practical.	Where Serving at Time of Examination.
				Paper No. 1.	Paper No. 2.	Written (Average Percentage).	Oral and Practical.		
19	Henstridge, M. E.	L.S.B.A.	23446	70	74	72	76	74	Cerberus
20	Whelan, F. L.	"	PM2730	69	75	72	76	74	Cerberus
69	Booth, L. S.	"	PM2647	69	82	75.5	72	74	Melville
88	Bennett, J. H.	L.S.B.A. (Ty.)	PA1382	78	69	73.5	70	72	Leeuwin
104	Stewart, F. S. R.	L.S.B.A.	21422	66	69	67.5	72	70	Rushcutter
105	Adam, T. R. H.	"	21698	86	63	74.5	77	76	Rushcutter
107	Farrelly, J. M.	"	21147	73	57	65	75	70	Penguin
108	Ingram, J. T.	"	S3027	71	75	73	72	72	Penguin
109	Barrell, A. A.	"	S5580	68	67	67.5	72.5	70	Penguin
135	Baker, M. J.	A/L.S.B.A. (Ty.)	B2621	88	82	85	73	79	Moreton
3	Lambeth, W. L.	S.B.A.	PM2774	78	73	75.5	73	74	Napier
15	Fuss, R. J.	"	PA2525	78	73	75.5	70	73	Manoora
16	Appel, L. E.	"	S6575	50	75	62.5	60	61	Manoora
17	Hill, A.	"	F4084	64	73	68.5	75	72	Manoora
22	Gothard, D. R.	"	PM5935	53	65	59	64	61	Cerberus
26	Batten, K. R.	"	PM6063	60	61	60.5	62	61	Cerberus
31	Robinson, D. W. F.	"	F4914	67	47	57	63	60	Cerberus
71	Noack, A. A. R.	"	F3757	56	60	58	87	72	Melville
80	Watters, R. C.	"	PM2990	60	90	75	85	80	Lonsdale
83	Majewski, R. T.	"	PM4141	50	72	61	65	63	Platypus
85	Owens, P. F.	"	F3696	53	77	65	66	65	Shropshire
86	Lucas, J. S.	"	PM2729	78	98	88	67	77	Adelaide
87	Hunt, R. H.	"	F3700	86	99	92.5	75	84	Adelaide
89	Bennett, C.	"	F3985	73	86	79.5	57	68	Leeuwin
94	Skewes, A.	"	PA1639	55	81	68	81	74	Torrens
95	Slec, R. H.	"	PA1912	48	60	54	67	60	Torrens
99	Hodgson, W.	"	S5927	50	63	56.5	70	63	Westralia
112	Webb, A. M.	"	22175	86	82	84	62	73	Rushcutter
113	Thompson, S.	"	S3872	75	87	81	68	74	Penguin
114	Mortimer, W. D.	"	S4512	65	75	70	64	67	Penguin
115	Wood, R.	"	S8188	62	81	71.5	58	65	Penguin
116	Boland, J. F.	"	S3271	67	79	73	60	66	Rushcutter
136	Cook, F. H.	"	22601	78	89	83.5	67	75	Moreton
137	Darley, D. L.	"	B3057	78	84	81	70	75	Moreton
111	Hallowell, L. J.	"	S6375	82	88	85	74	79	Rushcutter

2. The marks obtained by candidates who failed have been communicated to the Commanding Officer of the Ship or Establishment in which the rating was serving at time of the examination.

3. Papers from overseas vessels have, in some cases, not yet been received. If any examination papers should be forthcoming later, the results thereof will be published as soon as practicable.

4. The 23rd November, 1943, is to be regarded as the basic date for the passing of this examination.

5. The original copies of Forms A.S.1236 and A.S.1237 have been completed and forwarded to the Ships and Establishments concerned. Duplicate copies have been forwarded to the Naval Officer-in-Charge, Flinders Naval Depot. The necessary notation should be made on the Service Certificates of candidates.

(This Order will be reprinted for posting on Notice Boards.)

(465/207/952.)

105.

NAVAL BOARD OF ADMINISTRATION—BUSINESS MEMBER.

Mr. H. G. Brain, O.B.E., has been appointed Business Member of the Naval Board, as from 1st February, 1944, *vice* Mr. R. H. Nesbitt.

(712/205/306.)

106.

ACTING PETTY OFFICERS—IRREGULAR WEARING OF CLASS III UNIFORM.

It has been brought to the notice of the Naval Board that, contrary to the instructions contained in the Appendix to the Royal Navy List, a number of Acting Petty Officers are wearing Class III uniform (with gilt buttons) before being confirmed in the rating of Petty Officer.

2. On interrogation, certain of the ratings have stated that approval to wear this uniform was given by Commanding Officers for reasons of economy when nearing the due date for confirmation in rating, i.e., to avoid replacement of worn-out articles of uniform which would not be required with Class III uniform, or when ratings were being re-kitted following total loss of Class II uniform as a result of a Service casualty.

3. The wearing of Class III uniform by Acting Petty Officers is undesirable, and in no circumstances should an Acting Petty Officer be permitted to transfer from Class II to Class III uniform before being confirmed in the rating of Petty Officer.

4. Acting Petty Officers who, with Commanding Officer's approval, are now wearing Class III uniform are not required to transfer back to Class II uniform.

(434/215/1093.)

107.

SHUTTLE VALVES OF RECIPROCATING PUMPS—HEAT TREATMENT.

In view of the occurrence of a comparatively large number of defects attributed to distortion of the shuttle valves of reciprocating pumps fitted in A.M.S. Vessels and Frigates, it has been decided that these castings are to be heat treated during manufacture.

2. The castings, before machining, are to be heated to a temperature between 490° C. and 525° C. and held at this temperature for a period of about one hour per inch of mean thickness, and are then to be allowed to cool slowly in the furnace.

3. The treatment is to be given to the shuttle valve chests, shuttle valve and caps, and flat side valves, and contractors concerned have been informed of these requirements.

4. In the event of local arrangements being made for the manufacture of any of these parts, it should be ensured that this heat treatment is specified in the order.

(524/213/484.)

108.

ACCOUNTING FOR MACHINERY, MACHINE TOOLS, ETC., SUPPLIED FOR NAVAL WORKSHOPS.

1. The following procedure for accounting for Machinery and Naval Stores for Base Repair Workshops is to be observed.

2. Machinery, Machine Tools, Fixtures and Fittings are to be recorded in Fixture Lists which should be prepared on Forms D.792 and D.794 in triplicate. Certificates D.795 should be signed by the Officers concerned and the completed copies of the Fixture Lists disposed of as follows:—

Original.—For retention by the Officer responsible for the Workshops.

Duplicate.—To be forwarded to Naval Officer-in-Charge, Sydney (for information and reference purposes).

TriPLICATE.—To be forwarded to Director of Naval Stores, Navy Office.

3. Permanent stores required by the Workshops should be dealt with through the Naval Store Account of the Parent Ship or Depot in a similar manner to supplies for Services attached to the Parent Ship or Depot, the items being shown on permanent loan lists in the usual manner.

4. Base Repair Workshops should replenish stocks of consumable ready issue stores at regular monthly intervals. The stores should be drawn direct from the Base Naval Store by means of Form A.S.156, but it will not be necessary to quote the job numbers thereon. A simple form of record of such materials used for jobs should be maintained at the Workshops, care being taken that complete details of all material used for non Royal Australian Navy jobs, i.e., repayment services, are recorded. This procedure is designed to avoid the frequent demanding of small quantities of such stores, but where the quantities warrant it, stores should be drawn off for specific jobs, separate Forms A.S.156 being raised in such cases. This will simplify accounting and costing arrangements, particularly for repayment services.

NOTE.—The procedure outlined in paragraph 4 is not applicable at Sydney, Fremantle, Brisbane, Melbourne and Adelaide. Separate instructions as regards repair stores at these ports have been issued.

5. In view of the liability of items to rapid deterioration in the tropics, care is to be exercised that stocks in excess of those necessary for the efficient operation of the Workshops are not held in Base Repair Workshops in tropical areas. Particular care should also be taken by Base Accountant Officers in the regulation and preservation of stocks maintained in Base Naval Stores.

6. Upon receipt of machinery, machine tools, &c., at a Base, the Base Engineer Officer is to forward to the Director of Engineering (Naval) a certificate that the equipment has been received and recorded in his List of Fixtures, the page number of the Fixture List being indicated.

(612/212/2929.)

109.

**LUBRICATING OILS—H.M.A. SHIPS "KYBRA," "WILCANNIA"
AND "RESERVE."**

With reference to Navy Order 639 of 1943, the following Proprietary Brands of Lubricating Oil may continue to be used in H.M.A. Ships *Kybra* and *Wilcannia*:—

H.M.A.S. *Kybra*—Vacuum Oil Company Mineral Rarus Oil.
H.M.A.S. *Wilcannia*—Vacuum Oil Company D.T.E. "AA" Oil.

2. Approval has also been given for U.S. Navy Symbol 9370 Lubricating Oil to be used in H.M.A.S. *Reserve*.

(545/201/475.)

110.

REPAINTING OF A.M.S. VESSELS.

With reference to Navy Order 400 of 1943, it has been decided that, to ensure uniformity in the colour of A.M.S. Vessels, Chicago Blue Paint is to be used in future for the painting of these vessels.

(603/247/1698.)

111.

ANNUAL INSPECTION OF EXPLOSIVES EX H.M.A. SHIPS.

In connexion with the annual percentage examination and proof of explosive stores in accordance with Article 301 of Naval Magazine and Explosives Regulations (1941), it is observed that the following errors and omissions have been encountered by R.A.N. Armament Depots in dealing with samples landed from H.M.A. Ships:—

- (i) The appropriate forms, viz., S.1429A/O.27, S.1146, &c., are not rendered in numerous instances.
- (ii) Lines 5 and 8 of Form S.1429A/O.27, are frequently not completed.
- (iii) Incorrect quantities are often landed.
- (iv) In many cases, the provisions of Article 303 of Naval Magazine and Explosives Regulations have not been complied with, the packages being incorrectly marked and Return Notes not being suitably endorsed.

2. Such errors as the above, when committed by a number of ships, cause a great deal of avoidable delay and trouble in dealing with samples landed for test, and it is necessary that strict attention be paid to the full and correct compliance with the instructions concerned.

(471/201/1454.)

112.

**LOAN ISSUE OF BROWN DUNGAREE COMBINATION SUITS TO
OFFICERS.**

The provisions of Navy Order 58 of 1943 are extended to Officers of Base A/S Staffs engaged in *Ship fitting and maintenance*.

(434/214/543.)

113.

**USE OF SODA ASH IN LIEU OF SODA CRYSTALS FOR CLEANSING
PURPOSES.**

In the interests of economy, Granulated Soda Ash is being purchased for use in lieu of Soda Crystals as a cleansing agent.

2. The Soda Crystals at present in use are composed of 63 per cent. Water and 37 per cent. Soda Ash. When Soda Ash is being used, therefore, it should be borne in mind that more powerful alkaline solutions than are normally obtained when using Soda Crystals may be produced, and that such solutions are deleterious to linoleum, woodwork, and painted surfaces generally.

3. A satisfactory solution of Soda Ash for normal cleansing and boiling out purposes is four ounces of Soda Ash per gallon of water, and the use of a stronger solution should be avoided.

4. The attention of all concerned is to be drawn to the provisions of this Order.

(612/249/145.)

114.

CANVAS FLAG WALLET FOR A.M.S. VESSELS.

With reference to Navy Order 644 of 1943, approval has been given to the addition of the under-mentioned item to the list of special allowances of Naval Stores for A.M.S. Vessels to accommodate the Alarm Signal Flags referred to therein:—

Patt. No.	Description.	Qty.
12 (mod.)	Wallets, Canvas (3 tiers, each of 4 pockets).	1 No.

2. Supply of the above-mentioned item will be effected without demand by the Superintending Naval Store Officer, Sydney, as early as practicable.

(476/201/731.)

115.

ECONOMY IN CONSUMPTION OF BUTTER.

With reference to A.I.G. 103 signal No. 477 I, it has been decided to restrict as from 19th February, the issue of butter within the Naval Service in order to conform with the allowance applicable to A.M.F. and R.A.A.F.

2. Issues to General Mess and to Repayment Messes are therefore not to exceed a weekly total of $12\frac{1}{4}$ ounces per head, representing $1\frac{3}{4}$ ounces per diem for each officer or rating actually victualled.

(668/205/215.)

116.

CORRIGENDUM.

With reference to Navy Order 71 of 1943, for the words "50 per cent. salt and 50 per cent. fresh water" read "equal quantities of salt water and fresh water."

(434/201/3473.)

RESTRICTED.(FOR OFFICIAL USE ONLY.)

Commonwealth Navy Orders.

Navy Office, Melbourne,

7th March, 1944.

The following Orders, having been approved, are hereby promulgated for information and guidance, and necessary action.

By direction of the Naval Board,

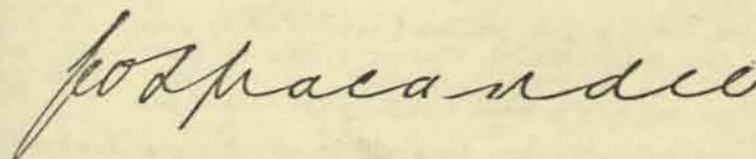

Secretary.

*The Rear-Admiral Commanding H.M.A. Squadron,
and Commanding Officers of H.M.A. Ships,
Officers in Charge of H.M.A. Naval
Establishments, and others concerned.*

TABLE OF CONTENTS.

No.	Subject.
117.	Victory Loan.
118.	Malaria Control—Drafting of Personnel.
119.	Promotion to Temporary Warrant Rank.
120.	Medical Examination Prior to Draft.
121.	Rockets 2" U.P. Failure.
122.	Ammunition Fuzes, Primers and Tubes—Tubes, Vent, Electric, 1 in. Mark IV, Lots 24, 28 and 35 of I.C.I. Manufacture, 1941.
123.	Small Arms—Line Throwers, Shoulder, Coston—Replacement by Rifles, M.L.E., Line Thrower.
124.	Fire Extinguishers for Motor Launches.
125.	Polarized Sun Glasses—Replacement by Pattern 4074 Anti-glare Spectacles.
126.	Life-saving Equipment—Torches and Sleeves for Inflatable Lifebelts.
127.	Report of Survey on Provisions or Other Victualling Stores—Form A.S.330—Rendition of.
128.	Women's Royal Australian Naval Service—Uniform and Clothing—Authorized Kits.
129.	Books and Forms.
130.	Forms and Cash Vouchers—Captain's Signature.
131.	Corrigendum.

C.2239/44.

117.

VICTORY LOAN.

The Government desires to emphasize that the success of the forthcoming Victory Loan is most important and desires that subscriptions should be made voluntarily by all sections of the community.

2. Approximately 750,000 of Australia's population are in the fighting Services and it is desired that every opportunity should be given to them to invest their savings in what is regarded as the best and safest investment in the Commonwealth.

3. Such money invested in War Loans not only bears the highest rate of interest now available, but also helps the finances of the country. Bonds and Certificates are always readily negotiable and provide a valuable addition to deferred pay and other savings which may be required to assist members in re-establishment in civil life after the war.

4. Bonds may be purchased outright or by instalments. Approval is given to the use of the allotment system where purchase of bonds by instalments is desired. Similarly, the purchase of War Savings Certificates may be made, *vide* Navy Order 59 of 1941.

5. The first Victory Loan will be open between March 28th and May 9th, 1944.

(This Order will be reprinted for posting on Notice Boards.)

118.

MALARIA CONTROL—DRAFTING OF PERSONNEL.

Instances have occurred in which personnel on draft to Darwin have been held up by the Military Authorities at staging camps *en route* and denied entry into the Northern Territory under Army regulations regarding malarial control.

2. Army Headquarters have now agreed to assume that, when personnel of other Services are drafted to the Northern Territory, due consideration has been given to the relative orders concerning malarial control by the Service concerned and such personnel will not henceforth be held up *en route*.

3. In view of the above, it is necessary that every care should be taken by Naval Authorities concerned to ensure compliance with Navy Order 275 of 1943.

4. With regard to service in sea-going ships in the north-eastern area, it has been approved that service in Cruisers, Destroyers, and L.S.I.'s employed in this area is not normally to be regarded as service in a malarious area for drafting purposes, nor is service in Sloops, Frigates or A.M.S. vessels, provided these are working from a base where there is a Commander (D) with a Medical Officer on his staff. Should, however, the nature of the duties on which any of these ships are employed lead to the contraction of malarial cases, or expose their personnel to abnormal risks of contraction of malaria, service in such ships will be regarded as service in a malarious area, and drafting authorities will be notified accordingly by Naval Board.

5. Service in M.L.'s, A.S.R. craft and other small vessels employed in the north-eastern area must be regarded as service in a malarious area.

(527/201/839.)

119.

PROMOTION TO TEMPORARY WARRANT RANK.

The following ratings are eligible for promotion to Temporary Warrant Rank subject to their being recommended and volunteers:—

- (a) Active Service Ratings.—Those who are within three years of completing their current engagement, have already completed last engagement, or have completed seventeen years' service.
- (b) R.A.F.R. Ratings.—Those who are recommended by their Commanding Officers and the Naval Officer-in-Charge, Flinders Naval Depot, as being fit to hold Warrant Rank.
- (c) R.N. Pensioners Mobilized for Service in the R.A.N.

2. It should be impressed upon Active Service Ratings volunteering for promotion that, after hostilities, they will be liable to demobilization as soon as their services are no longer required, provided that the period of their engagement current at date of promotion has expired; they will not be allowed to revert to their previous rating. This procedure also applies to Auxiliary Service ratings who may volunteer and be promoted.

3. A rating to be recommended for promotion to Temporary Warrant Engineer or Warrant Mechanician must be qualified in accordance with paragraph 2 of A.F.O. 5127/42.

4. Recommendations for Temporary Warrant Rank are to be made on Form A.S.198 in duplicate on 1st April and 1st October, the original being forwarded to Navy Office and the duplicate to the Naval Officer-in-Charge, Flinders Naval Depot.

5. On the first occasion on which a rating is recommended for Temporary Warrant Rank copies of his Service Certificate and History Sheet are to accompany the original and duplicate Forms A.S.198 to Navy Office and the Naval Officer-in-Charge, Flinders Naval Depot, respectively.

6. Returns rendered in respect of the Executive Branch should state whether recommendation is for Gunner, Gunner (T) or Boatswain. Those holding First class gunnery non-substantive rates are eligible for Gunner and those holding the T.G.M., L.T.O., or L.T.O. (L.P.) non-substantive rates are eligible for Gunner (T).

7. A rating to be eligible for promotion to Temporary Warrant Rank must be medically fit for general service, and this fact is to be noted on Form A.S.198. A further medical examination is to take place immediately before promotion.

8. No rating will be selected for promotion in order to fill a specific appointment; those promoted will be liable for appointment to any of H.M.A. Ships or Establishments where their services are required.

9. A roster of recommended volunteers will be kept at Navy Office and the following factors will be taken into consideration when determining position on the Roster:—

- (i) Seniority.
- (ii) Whether qualified professionally and/or educationally for Warrant Rank.
- (iii) Date of recommendation.
- (iv) Nature of recommendation.

10. In the event of a Commanding Officer deciding not to recommend a rating who has been previously recommended, the fact should be reported on the ensuing Half-Yearly Return; such rating will be automatically removed from the Roster until a further recommendation is received.

11. Whenever a petty officer or rating who has been recommended for promotion to Temporary Warrant Rank commits an offence which renders him ineligible for promotion to Warrant Rank (K.R. and A.I Article 306, clauses 2 and 8), the fact is to be reported by signal to the Naval Board and the Naval Officer-in-Charge, Flinders Naval Depot.

12. The Naval Officer-in-Charge, Flinders Naval Depot, may recommend to the Naval Board that the name of a rating should be removed from the Roster. If the recommendation of the Naval Officer-in-Charge, Flinders Naval Depot, be approved, the ship in which the rating is then serving will be informed.

13. If a rating whose name has been entered on the Roster subsequently declines promotion for any cause, his name will be removed from the Roster and will only be reinstated with the approval of the Naval Board on application through his Commanding Officer. He would then be placed at the bottom of the Roster.

14. The fact that a rating has been recommended is to be noted on page 2 of his Service Certificate and also on his History sheet.

(568/202/953.)

(This Order will be reprinted for posting on Notice Boards.)

120.

MEDICAL EXAMINATION PRIOR TO DRAFT.

It has come to notice that the instructions contained in C.O.R., Art. 566, clause 2, are not being fully carried out.

2. Commanding Officers of ships and establishments are to ensure that all personnel are medically examined in order to determine fitness for draft, both on receipt of appropriation and immediately prior to draft.

(527/203/756.)

121.

ROCKETS 2" U.P. FAILURE.

A case has recently occurred wherein a 2" rocket, one of four, failed when being fired from a Pillar Box.

2. Examination of this rocket established the cause as being due to loose and dirty connexions at the base of the rocket case.

3. Attention is drawn to B.R.816, paragraph 23, Tests and Maintenance of Ammunition.

(471/208/940.)

122.

AMMUNITION FUZES, PRIMERS AND TUBES—TUBES. VENT, ELECTRIC, 1-in. MARK IV, LOTS 24, 28 AND 35 OF I.C.I. MANUFACTURE, 1941.

Appended for information and action as necessary is copy of Admiralty Fleet Order 6237/43, which has not yet been promulgated on the Australia Station:—

"All tubes of the above description on board H.M. ships at home and abroad are to be landed at the nearest Naval Armament Depot at the first opportunity.

2. These tubes are to be regarded as coming under category (b) C.A.F.O. 991/42.

3. At Naval Armament Depots home and abroad, all tubes of this description, together with any received under this order, are to be brought to produce.

(C.A.F.O. 991/42.)"

(408/203/612.)

123.

**SMALL ARMS—LINE THROWERS, SHOULDER, COSTON—
REPLACEMENT BY RIFLES, M.L.E., LINE THROWER.**

In view of the fact that sufficient stocks of cartridges S.A. 50/70 Remington are available to meet requirements for a considerable time, the provisions of Admiralty Fleet Order 5228/43 are not to apply in the Royal Australian Navy. Ships holding Line Throwers Shoulder Coston are therefore to retain them.

(412/202/396.)

124.

FIRE EXTINGUISHERS FOR MOTOR LAUNCHES.

Approval has been given to the addition of the undermentioned item in the lists of Special Allowances of Naval Stores for Fairmiles and H.D.M.Ls. in the quantities indicated, for protection against fire in the galleys or refrigerating machines in these vessels:—

Patt. No.	Description.	Quantity.	
		Fairmiles.	H.D.M.Ls.
—	Fire Extinguishers, hand, CO ₂ , "Lux" type, 12 lb.	3 No.	2 No.

2. Approval has also been given to the provision of spare CO₂ Cylinders to all M.L. Bases, in quantities considered adequate for the number of Fairmiles and H.D.M.Ls. based thereon.

3. First supply of the above-mentioned extinguishers and spare cylinders will be effected without demand by the Superintending Naval Store Officer, Sydney, as soon as stocks become available.

(603/246/3488.)

125.

**POLARIZED SUN GLASSES—REPLACEMENT BY PATTERN 4074
ANTI-GLARE SPECTACLES.**

With reference to Navy Order 30 of 1944, Polarized Sun Glasses should be returned to the nearest Naval Store Depot, at the first opportunity after receipt of supplies of the Pattern 4074 Anti-Glare Spectacles.

(612/236/7507.)

126.

**LIFE-SAVING EQUIPMENT—TORCHES AND SLEEVES FOR
INFLATABLE LIFEBELTS.**

With reference to C.A.F.O's 191/43 and 1173/43, arrangements are now being made for the manufacture of R.A.N. requirements of Torches and Sleeves.

2. Issues will be made on the following basis:—

Cruisers—20 per cent. of ship's complement.

All other H.M.A. Ships, including H.D.M.L's and Air Sea Rescue Vessels—100 per cent. of ship's complement.

3. Demands should accordingly be made for—

(a) Torches and batteries—on Superintending Naval Store Officer, Garden Island, or nearest Naval Store Depot.

(b) Sleeves—on Victualling Store Officer, Royal Edward Victualling Yard.

(612/231/292.)

127.

**REPORT OF SURVEY ON PROVISIONS OR OTHER VICTUALLING
STORES—FORM A.S.330—RENDITION OF.**

The attention of Commanding Officers, and Accountant Officers where borne, is drawn to the instructions contained in C.O.R., Article 439, in regard to the preparation and rendition of Form A.S.330—Report of Survey on Provisions or Other Victualling Stores Damaged, Defective or Decayed.

2. Instructions for rendering these Reports of Survey are set forth at the top of Form A.S.330 and are to be strictly complied with in future. Special reference is made to the necessity for the original Form A.S.330 to be despatched to the Director of Victualling by first opportunity and for a certificate to be inserted in the body of the Form and signed by each Officer witnessing the destruction of condemned stores on board.

3. Navy Orders 46 and 284 of 1943 are hereby cancelled.

(612/243/975.)

128.

**WOMEN'S ROYAL AUSTRALIAN NAVAL SERVICE—UNIFORM
AND CLOTHING—AUTHORIZED KITS.**

The authorized articles of loan clothing for V/Signallers, Telegraphists and Messengers on duty in Port War Signal Stations, *vide* paragraph 4 (g) of Navy Order 375 of 1943 and Navy Order 55 of 1944 are increased by 1 No. cap (stoker ratings caps).

2. All copies of Navy Order 375 of 1943 held are to be amplified accordingly.

(516/201/622.)

BOOKS AND FORMS.

First supplies of the undermentioned publications have been distributed. Further supplies of B.R.638 and B.R.815 are being obtained to complete distribution:—

B.R.4, Part II.—Naval Storekeeping Manual—Naval Aircraft Instructions—Pages 1-4, Chapter IX.

(A.F.O. 4642/43.)
(571/202/1618.)

B.R.70/43.—Cumulative Supplement corrected to 30th September, 1943.

(571/202/1654.)

B.R.141/43.—R.M. Clothing Appointments, Issuing Prices, etc.

(571/202/1840.)

B.R.222.—Notes on W/T Sets—Issue of New Pages.

(A.F.O. 3758/43.)
(571/202/1584.)

B.R.318.—Regulations for the Conveyance of Government Explosives by the Railway Companies, 1942.

(571/202/1753.)

B.R.323.—Establishment of Naval Stores for Gunnery Purposes and Form D.128, 1—List of Particulars—Lists of Errata No. 9.

(A.F.O. 312/43.)
(571/202/1416.)

B.R.634G.—Dictionary of Naval Equivalents—German—English.

(A.F.O. 6086/42.)
(571/202/1683.)

B.R.638.—Handbook for Echo Sounding Sets, Types 758 N.P.S.Q.

(A.F.O. 3760/43.)
(571/282/1718.)

B.R.771 (Late A.S.1422).—Handbook for Echo Sounding Sets, Types 761 and 761P.

(A.F.O. 4507/43.)
(571/202/1838.)

B.R.815.—Handbook for Echo Sounding Sets, Types 762, 763 and 763A.

(A.F.O. 4507/43.)
(571/202/1820.)

B.R.832/43.—The Lanchester Carbine Manual (9 mm. Lanchester Machine Carbine).

(A.F.O. 3640/43.)
(571/202/1804.)

B.R.835/43 (Late B.R.7A/43).—Security of Shipping Information.

(A.F.O. 4882/43.)
(571/202/1842.)

B.R.846/43.—Drill for High Angle Control System, Mark IV.

(A.F.O's. 3868 and 4882/43.)
(571/202/1830.)

British Aeroplanes—Issue of Slips for Sheets B.4 and D.1, A3 and D1.

(A.F.O's. 2085 and 2559/43.)
(571/201/3544.)

Anti-Aircraft Procedure.

Instructions (Aust.) No. 1—Addendum No. 1.

Instructions (Aust.) No. 4—Addendum No. 1.

Instructions (Aust.) Nos. 8, 13, 14, 17 and 19.

(571/201/3921.)

Pamphlet—"Information for the Guidance of Officers engaged in the Transport of Service Explosives under Wartime Conditions."

(571/201/4012.)

British Survey, Volume IV.

Nos 22 to 26 and Volume 5.

No. 1 and Supplement.

(A.F.O. 4507/43.)
(571/201/4013.)

Aircraft Recognition Journal, Volume 1, Nos. 9 and 12.

(A.F.O. 4507/43.)
(415/201/1879.)

Aircraft Silhouettes (Large Wall Size).

Issue No. 1, April 1943 (Sets of 16).

Issue No. 2, July 1943 (Sets of 15).

(A.F.O. 4507/43.)
(415/201/1930.)

Form S.1098—Errata 6 and 7.—Alphabetical List of Consumable Naval Stores.

(A.F.O's. 5096/42 and 3500/43.)
(480/202/4156.)

2. The undermentioned publications are now obsolete, and all copies should be disposed of in accordance with instructions laid down in B.R.1—Books of Reference and I.D. Catalogue:—

B.R.149.—Methods of Artificial Respiration to be used in War-time according to the cause of Asphyxia.

(A.F.O. 5149/43.)
(571/202/1496.)

B.R.172.—Part I—(Late O.U.5328)—

Handbook of the Vickers 40 mm. Automatic Gun.
 Ordnance, Q.F. 2 pdr., Pom Pom, Mark II*.
 Part II—Notes for the Officer of Quarters.

B.R.172(1).—Addendum No. 1 to B.R.172.

(A.F.O. 3865/43.)
 (571/202/1578.)

B.R.209/1935.—Drill for 2 pdr. Q.F. Mark II*.

Pom Pom Guns on H.A. Mark II Mountings.

(A.F.O. 3865/43.)
 (571/202/904.)

130.

FORMS AND CASH VOUCHERS—CAPTAIN'S SIGNATURE.

With reference to Naval Account Regulations and Instructions, Article 56, in order to relieve Commanding Officers of clerical duties during the period of the war, it has been approved to dispense with their signatures on the following forms:—

A.S.22—Voucher for purchase.

A.S.22A—General expenses.

A.S.27—Petty Cash.

In addition to the certificates already given by him on these Forms, the Accountant Officer will complete the certificates at present given by the Commanding Officer by signing "for Captain".

2. The initials of the Commanding Officer on Form A.S.18 (Casual Payments) and of Captain on Form A.S.57 (Officer's Pay Sheet) may also be dispensed with.

3. The general responsibility of the Captain for all expenditure incurred remains, and particular attention is drawn to Naval Account Regulations and Instructions, Article 84, clause (1), regarding the necessity for examination of the Cash Account and supporting vouchers before transmission to the Director of Navy Accounts.

(404/201/638.)

131.

CORRIGENDUM.

The heading of Navy Order 54 of 1944 is to be amended to read "MARKING OF CARTRIDGES WITH SUB-LOT XJ-M.Ls."

RESTRICTED.(FOR OFFICIAL USE ONLY.)

Commonwealth Navy Orders.

Navy Office, Melbourne,
14th March, 1944.

The following Orders, having been approved, are hereby promulgated for information and guidance, and necessary action.

By direction of the Naval Board,

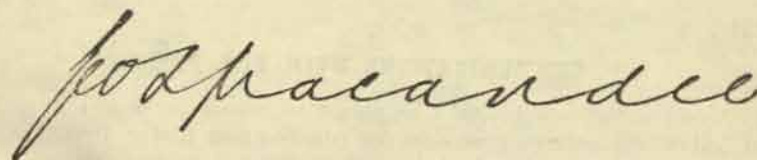

Secretary.

*The Rear-Admiral Commanding H.M.A. Squadron,
and Commanding Officers of H.M.A. Ships,
Officers in Charge of H.M.A. Naval
Establishments, and others concerned.*

TABLE OF CONTENTS.

No.	Subject.
132.	Grant of Full and Modified "Qualified Officer" Status in the R.A.N.
133.	Communications with the Press.
134.	R.A.N. Pattern Haze Screens—Modification.
135.	R.A.N. Establishments of Naval Stores.
136.	Emergency Water Ration for Personnel at Sea—Supply of Water Bottles.
137.	Web Equipment Pattern 1937.
138.	Chocolates and Confectionery for Naval Canteens and Messes.
139.	Modification of Procedure for Accounting for Naval Stores Incorporated in W/T, A/S, Radar, &c., Sets.

132.

GRANT OF FULL AND MODIFIED "QUALIFIED OFFICER" STATUS IN THE R.A.N.

The attention of Officers concerned is drawn to the necessity for full compliance with the provisions of A.F.O. 4916/43 concerning the grant of "Qualified Officer" status. A high standard of professional ability must be maintained.

2. In the case of Engineer Officers, it is brought to notice that the number who have obtained "Qualified Officer" status is comparatively small. The claims of Engineer Officers holding responsible appointments should be carefully examined and where Officers are considered to be qualified, recommendations should be forwarded to the Naval Board.

(568/201/913.)

133.

COMMUNICATIONS WITH THE PRESS.

Cases have been brought to notice in which personnel have failed to follow the correct procedure in contributing to the Press, or other publicity media, material on Service and non-Service subjects.

2. The attention of all personnel is directed to Consolidated Orders and Regulations, Article 230, and Navy Order 316 of 1941, which set out the procedure to be adopted in relation to publicity and to public comment.

(1835/2/608.)

134.

R.A.N. PATTERN HAZE SCREENS—MODIFICATION.

With reference to A.F.O. 4340/43, relative to the modification of the Admiralty Pattern 952 Haze Screen, the Haze Screen in use in the R.A.N. is of slightly different construction to the Admiralty Pattern, and only requires modification as follows:—

"See A.F.O. Diagram 266/43. Fit mask runners (Diag. 2, 6132), one on each side at the required distance apart (Diag. A. 6132); the mask (Diag. 1, 6132) should be a tight slide fit, and should remain in any required position without support."

2. Ships concerned are to make and fit the gear from their own resources.

(612/255/44.)

135.

R.A.N. ESTABLISHMENTS OF NAVAL STORES.

It is promulgated for information that the under-mentioned R.A.N. Establishments of Naval Stores, as distinct from Admiralty Printed Establishments, have been distributed to all Authorities concerned:—

Establishment of Naval Stores for H.M.A. Boom Defence Depots	L.E. 1
Establishment of Naval Stores for R.A.N. Shore Wireless Stations	L.E. 2
Establishment of Naval Stores for Air-Sea Rescue Vessels	L.E. 3
Establishment of Naval Stores for Controlled Mining (O) Laying Parties	L.E. 4
Establishment of Naval Stores for Controlled Mining Base	L.E. 5
Establishment of Naval Stores for C/M Minelaying Tenders	L.E. 6
Establishment of Naval Stores for C/M and C/M.O. Stations	L.E. 7
Establishment of Naval Stores for Maintenance of Motor Launches and Ford V8 Engines	L.E. 8
Establishment of Naval Stores for Motor Patrol Boats	L.E. 9
Establishment of Naval Stores for Base Repair Depots	L.E. 10
Establishment of Naval Stores for Naval Beach Parties	L.E. 11
Establishment of Naval Stores for Naval Beach Commando	L.E. 12
Establishment of Naval Stores for Ordnance Base Staffs	L.E. 13
Establishment of Naval Stores for Port Director Units	L.E. 14
Establishment of Base A/S Spares	L.E. 15
Establishment of Base E/S Spares	L.E. 16
Establishment of Base Spares for 25 KW. Diesel Generators	L.E. 17

2. Identification numbers have been allocated to R.A.N. local Establishments (L.E.) as indicated above, and all distributed copies of the various Establishments should be endorsed with the relevant L.E. No.

(612/226/1225.)

136.

EMERGENCY WATER RATION FOR PERSONNEL AT SEA—SUPPLY OF WATER BOTTLES.

To provide an emergency water ration for personnel at sea, H.M.A. Ships (M.L's and above) are in future to carry a water bottle for every person on board, with spare in the proportion of one per 20 men or less.

2. Additional web equipment (carrier and brace) will not be provided. Suitable arrangements for carrying the water bottle in an emergency are to be improvised on board.

3. Ships concerned are to forward demands to complete to the Administrative Authority, by whom requirements are to be consolidated as necessary and forwarded to the nearest Naval Armament Depot.

(668/201/2665.)

137.

WEB EQUIPMENT PATTERN 1937.

Stocks of web equipment Pattern 1937 are now sufficient to enable the following H.M.A. Ships to be outfitted with this type in exchange for Patterns 1908 and 1919:—

Cruisers.
Destroyers.
Sloops.

2. Amendments of ships' warrants will be issued by Superintending Armament Supply Officer, Spectacle Island, Sydney.

3. Ships concerned are to demand from the Naval Armament Depot, Sydney, at the next convenient opportunity, requirements of web equipment Pattern 1937 and are to return Patterns 1908 and 1919 on receipt of the new equipment.

(402/201/226.)

138.

CHOCOLATES AND CONFECTIONERY FOR NAVAL CANTEENS AND MESSES

With reference to Navy Order 596 of 1943, it is notified that purchases of chocolates and confectionery for naval canteens and messes are to be restricted to the following quantities of each item:—

- (a) In ships and establishments in forward operational areas—
24 lb. per head per annum.
- (b) In other sea-going ships and in other shore establishments north of the Tropic of Capricorn—12 lb. per head per annum.
- (c) In shore establishments south of the Tropic of Capricorn—
5 lb. per head per annum.

2. All orders for chocolates and confectionery placed by canteens of sea-going ships are to be submitted to the Deputy Director of Service Foodstuffs prior to lodgement with manufacturers, and are to be endorsed by the Commanding Officer, or an officer acting on his behalf, to the effect that the quantities ordered are within the authorized allowances as set out in paragraph 1 above.

3. Orders should normally be placed for one month's requirements at a time. Where, owing to the projected movements of a ship, it is necessary to place an order for more than one month's requirements, subsequent orders are to be reduced to keep the quantities purchased over a period within the authorized allowances.

(668/204/90.)

139.

MODIFICATION OF PROCEDURE FOR ACCOUNTING FOR NAVAL STORES INCORPORATED IN W/T, A/S, RADAR, ETC., SETS.

With reference to A.F.O. 3851/41, under the present procedure the various items of naval stores incorporated in W/T, A/S, &c., sets, and which, collectively, form the complete set, are accounted for in the naval store accounts of ships and establishments as individual units, each item being allocated a separate ledger page on which details of the items actually incorporated in the set as components, or working parts, are shown separately from quantities of similar items which may be held either in the naval store, or by the departmental officer concerned, as spares to be used in case of replacement of a component, or working part of the set.

2. It has been decided to simplify the accounting procedure for these equipments by dealing with the actual components of each individual set as one complete unit for store accounting purposes. The underlying principle is that the several individual components of each set are essential to its satisfactory performance, and that if the particular set is fulfilling its service function satisfactorily, it may be accepted that these essential components are duly present in the set. It is not desired that any alteration should be made to the accounting procedure in force in existing ships and establishments, except in the circumstances referred to hereunder, and the following modifications will, for the time being, be instituted only in vessels under construction, and in instances where it is necessary to prepare new naval store ledgers. The modified system may also be put into force in ships in commission, or under refit, and in shore establishments, where a set is replaced completely by another set, or where an additional set is supplied. In these latter instances, the services of an Inspecting Officer (Naval Storekeeping) may be applied for to assist in effecting the necessary alterations to the naval store ledgers.

3. The modified method of accounting will be as follows:—

- (a) One ledger page will be used for each complete set, the components of which are detailed in the relevant establishment list.
- (b) On receipt of supply notes indicating the separate components comprising the complete set, they should be compared with the relevant establishment list for the set, and the set then taken on charge as—

W/T Transmitting Set Type..... comprising
components as detailed in establishment list
No..... 1 No.

The ledger page should be noted on the vouchers for the several components, and the vouchers then bundled in the usual manner.

- (c) The complete set should be issued on permanent loan as a set, and shown in the appropriate permanent loan list as described on the ledger page *vide* (b) above, a copy of the relevant establishment list being filed with the loan list.

(d) Spares and accessories, both permanent and consumable, which are allowed by establishment, will continue to be accounted for as at present, i.e., a separate ledger page is required for each description of item. When an accessory of a permanent nature is issued on permanent loan, it should be recorded in the permanent loan columns of the ledger and recorded separately on the permanent loan list. When, however, a spare permanent item is issued in lieu of a defective component of a complete set, it should be issued outright and written off charge in the serviceable column of the ledger. The defective item should be taken on charge as unserviceable and later returned to the dockyard, a serviceable item being obtained in lieu to restore the spares carried in the ship to the authorized allowance as per the establishment list concerned.

Whilst all transactions in the spares and accessories should be recorded in the ledger, the establishment list for the particular set should only be noted when a reduction, or addition, to the original quantity of a component is involved, i.e., when a component is returned defective and replaced by a serviceable spare no alteration is necessary in the establishment list.

(e) In the event of a component of a set, a spare of which is not allowed *vide* the establishment list, requiring replacement, it will be necessary for the defective component to be taken on charge in the unserviceable ledger, and written off charge on return to a naval store depot. When the replacement is received from the Naval Store Officer, the item should be taken on charge in the serviceable stores ledger, issued outright and written off charge therein. It will be noted that such transactions will be recorded in the ledger, but the items will not remain on charge therein. In order to avoid raising a separate ledger page for each such item, a ledger page for each separate set or assembly should be raised, and all transactions in the components thereof for which spares are not carried recorded therein.

4. The appendix to this Order illustrates the ledger posting involved in the various transactions referred to.

5. The above procedure is applicable to each set comprised under the following headings, the details of the components of which are incorporated in establishment lists of stores:—

W/T.
Radar.
A/S.
E/S.
Wa/T.
Hydrophone.
Sound Reproduction.
VC/VF.

(612/212/2688.)

APPENDIX.

S.—153. LEDGER FOR PERMANENT STORES.

Complete Set vide Paragraph 3.

F.1.—W/T Transmitting Set Type 35S comprising Components as detailed in Establishment List No. T.17. No.

Date.	Voucher No.	Serviceable Stores.			Grand Total on Loan.	Unserviceable Stores.			Date.	Voucher No.	Torpedo W/T.		
		Re-ceipts.	Issues.	Re-mains.		Re-ceipts.	Issues.	Re-mains.			Issued.	Re-turned.	Total on Loan.
1944.	First Charge.								1944.				
Aug. 8	9713	1		1									
	9720				1				Aug. 15	8156 4003 W/T	1		1

NOTES.—A. Entry for receipt of set from Dockyard.
B. Entry for issue of set on Permanent Loan to W/T Department.

COMPONENT PARTS NOT CARRIED AS SPARE PER ESTABLISHMENT LIST OF STORES.
Patt. 4530A. Ammeter 4½" Dial Hot Wire.

Sept. 10	W/T 1051					1		1				
" 15	714							1		Nil		
" 18	9804	1		1								
" 18	W/T 4172		1									
								1		Nil		
Oct. 12	W/T 1162							1		1		
" 13	821									Nil		
" 27	10062	1		1								
" 27	W/T 5021		1									

NOTES.—A. Entry for return of unserviceable items from W/T Department to Naval Store.
B. Entry for return of unserviceable item from ship to Dockyard.
C. Entry for supply of serviceable item in lieu from Dockyard.
D. Entry for supply of serviceable item in lieu to W/T Department.

SPARES ALLOWED BY ESTABLISHMENT.

Aug. 8	8432	1		1				1*		1		
Aug. 31	W/T 1001											
Aug. 31	W/T 416		1	Nil								
Sept. 4	702							1		Nil		
" 15	9708	1		1								

NOTES.—A. Initial supply from Dockyard.
B. Return of unserviceable item from W/T Department and issue of serviceable item in lieu.
C. Return of unserviceable item to Dockyard.
D. Supply of serviceable item in lieu from Dockyard.

* Component incorporated in set and not on separate ledger charge.

ACCESSORIES ALLOWED BY ESTABLISHMENT.

Aug. 8	8434	1		1									
" 10	W/T 1005								Aug. 10	W/T 1005	1		1
Sept. 15	W/T 4057		1	Nil	Nil	1		1	Sept. 15	W/T 4057		1	Nil
" 17	704							1		Nil			
" 24	9031	1		1									
" 25	W/T 1020				1				Sept. 25	W/T 1020	1		1

NOTES.—A. Initial Supply from Dockyard.
B. Issue on Permanent Loan to W/T Department.
C. Return of unserviceable item to Naval Store from W/T Department.
D. Return of unserviceable item to Dockyard.
E. Receipt of serviceable item in lieu from Dockyard.
F. Issue of serviceable item to W/T Department on permanent loan.

By Authority: H. E. DAW, Government Printer, Melbourne.

RESTRICTED.(FOR OFFICIAL USE ONLY.)

Commonwealth Navy Orders.

Navy Office, Melbourne,
21st March, 1944.

The following Orders, having been approved, are hereby promulgated for information and guidance, and necessary action.

By direction of the Naval Board,

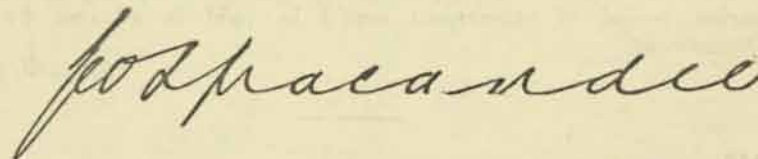

Secretary.

*The Rear-Admiral Commanding H.M.A. Squadron,
and Commanding Officers of H.M.A. Ships,
Officers in Charge of H.M.A. Naval
Establishments. and others concerned.*

TABLE OF CONTENTS.

No.	Subject.
140.	General Messages of "H" and "I" Series Remaining in Force.
141.	Liaison Between Naval and Air Force Officers Engaged on Convoy Protection—Pay Arrangements.
142.	Ammunition—20 mm., 40 mm. and 2 pdr.—20 mm. Oerlikon H.E.—Liability to Caps of Cartridges Blowing Out When Modified Breech Face Pieces (Mark II) Are Fitted—Withdrawal of Certain Lots—Reports.
143.	4-in. Gunmountings Marks XXIII and XXIII*—Fitting Recoil Cylinders.
144.	Failure of Gun Armament Material and Ammunition.
145.	D.C. Pistol History Sheets—Details Required.
146.	Kites and Drogues For Anti-Aircraft Targets—Discontinuance of Supply.
147.	Compensation for Total Loss of Uniform and Clothing—Ratings.

C.2685/44.

140.

GENERAL MESSAGE OF "H" AND "I" SERIES REMAINING IN FORCE.

A list will be promulgated monthly by mailgram to ships and authorities of A.I.G. 103 indicating General Signals of "H" and "I" Series no longer effective, or otherwise sufficiently promulgated, and which may consequently be cancelled.

(622/205/1464.)

141.

LIAISON BETWEEN NAVAL AND AIR FORCE OFFICERS ENGAGED ON CONVOY PROTECTION—PAY ARRANGEMENTS.

With reference to Navy Order 599 of 1943, the Department of Air has requested that no pay advances be made to R.A.A.F. Officers while attached to H.M.A. Ships during their leave, as any pay falling due during period of attachment would be paid in advance by that Department.

(559/223/59.)

142.

AMMUNITION—20 MM., 40 MM., AND 2 PDR.—20 MM. OERLIKON H.E.— LIABILITY TO CAPS OF CARTRIDGES BLOWING OUT WHEN MODIFIED BREECH FACE PIECES (MARK II) ARE FITTED—WITHDRAWAL OF CERTAIN LOTS—REPORTS.

Appended for information and necessary action is copy of Admiralty Fleet Order 300/44 which has not yet been promulgated on the Australian Station:—

"Twenty millimetre Oerlikon ammunition of the undermentioned lots has caused stoppages owing to the caps of the cartridges blowing out when using Mark II breech face pieces, and is to be withdrawn from service, viz.:—

American Lot of H.E.	N.F.E. 485H.
American Lot of H.E.	W.C.C. 64

(C.A.F.O. 1956/43
refers).

2. All ammunition of these lots on board ships is to be returned to the nearest Naval Armament depot at the first opportunity and ammunition of other lots drawn in lieu. D.E.M.S. Staff Officers are to arrange for similar action to be taken in merchant ships.

3. Naval Armament depots are to set aside any of these lots in store or subsequently received and report quantities available by 1st February, 1944, when disposal instructions will be given. Nil reports are not required.

(C.A.F.O. 1956/43.)"

(408/206/1347.)

143.

4-IN. GUNMOUNTINGS MARKS XXIII AND XXIII*: FILLING RECOIL CYLINDERS.

When filling or topping up the recoil cylinders of the above mountings, it is most important that at least 50 per cent. of glycerine is used.

2. Any cylinders which have been topped up with distilled water only should be drained, and the liquid replaced with liquid containing at least 50 per cent. glycerine in accordance with the instruction shown on the gun.

3. Base ordnance staffs are to instruct ratings responsible for this duty on small ships, should any doubt exist as to the procedure.

4. Ships' officers are to ensure that an ample supply of glycerine is carried on board for this purpose.

(674/205/2474.)

144.

FAILURE OF GUN ARMAMENT MATERIAL AND AMMUNITION.

Attention is directed to the procedure to be followed in rendering forms S.1148 (h) and (i).

2. This is laid down in B.R. 862, Naval Magazine and Explosives Regulations, Article 310 and 318 and on Form S.1148 (h) as reprinted in 1938, Notes 1 to 4.

(490/210/361.)

145.

D.C. PISTOL HISTORY SHEETS—DETAILS REQUIRED.

With reference to Navy Orders 348 of 1942 and 149 of 1943, history sheets of expended depth charge pistols continue to be received at Navy Office with essential details of expenditure omitted.

2. On all occasions when history sheets of expended depth charge pistols are forwarded to Navy Office, they are to be completed in all respects.

3. The following details are always to be clearly indicated:—

- (i) Allocation of pistol and date.
- (ii) Service on which expended, i.e., Action, Practice, Trials, &c.
- (iii) Was detonation satisfactory?
- (iv) Signature of Commanding Officer and name of ship.

(471/205/2092.)

146.

KITES AND DROGUES FOR ANTI-AIRCRAFT TARGETS. DISCONTINUANCE OF SUPPLY.

In view of the unrealistic target provided by kites and drogues for anti-aircraft practice, no further supplies of these items are being made, and the stocks at present held should be returned to the nearest Naval Store Depot.

2. Navy Order 283 of 1942 is cancelled.

(612/255/22.)

147.

**COMPENSATION FOR TOTAL LOSS OF UNIFORM AND CLOTHING
—RATINGS.**

It has been observed from Navy Office copies of Ships' Ledgers and Clothing Accounts that compensation in respect of uniform and clothing articles totally lost by ratings, as a result of a Service casualty, has been awarded in cash and/or kind by Commanding Officers under the provisions of Navy Order 47 of 1942, but no action has been taken in many instances to obtain the covering approval of the Naval Board to the compensation awarded, as required by paragraph 1 of the Navy Order quoted.

2. It is to be specially noted by Commanding Officers, therefore, that full particulars of compensation awarded, in cash and/or in kind, to R.N. or R.A.N. ratings under the above-mentioned authority, whether as advance or compensation pending finalization of claim by next Ship or Establishment, or in total satisfaction of the claim, are to be invariably reported without delay to the Naval Board, by separate memorandum, for covering approval.

(438/204/208.)

Library

RESTRICTED.

(FOR OFFICIAL USE ONLY.)

Commonwealth Navy Orders.

Navy Office, Melbourne,

28th March, 1944.

The following Orders, having been approved, are hereby promulgated for information and guidance, and necessary action.

By direction of the Naval Board,

J. O. Macandee

Secretary.

*The Rear-Admiral Commanding H.M.A. Squadron,
and Commanding Officers of H.M.A. Ships,
Officers in Charge of H.M.A. Naval
Establishments, and others concerned.*

TABLE OF CONTENTS.

No.	Subject.
148.	Port Directors.
149.	Selection of Ratings for Divers.
150.	Personnel Serving at Northern Bases.
151.	Ammunition—20-mm. Oerlikon—Clearing Charges.
152.	Ammunition—Miscellaneous A.A.D. Weapons—Tails Propelling Rockets U 2-in., Marks II and III, Filled, Kirby, Lots 32, 33, 136, 178, 179 and 182—Restriction.
153.	Fuzes Time No. 401 Marks I and IA.
154.	Issue of Free Kits to Ratings on Entry.
155.	Torpedo Igniters, Mark XI, Lot No. 217, Filled B.R. 12/41—Withdrawal. C.2956/44.

148.

PORT DIRECTORS.

With reference to Navy Order 597 of 1943, Port Directors have now been appointed at Saidor, Cape Gloucester and Arawe.

2. The title of "Port Director, Langemak" has been altered to "Port Director, Langemak Area".

3. The appointment of Port Director, Woodlark Island, has been cancelled.

(1937/2/231.)

149.

SELECTION OF RATINGS FOR DIVERS.

Care must be taken in the selection of a man if he is to be an efficient diver.

2. Before recommendation on Form A.S. 1303, he is to be examined in accordance with the following requirements:—

(a) General—

He must be—of good character,
of good physique,
less than 30 years of age,
less than 15 stone in weight,
less than 6 ft. 1 in., and more than 5 ft. 4 in.
in height.

He must not be—fat, or tend to fatness,
of a nervous or excitable temperament.

(b) He must pass the medical examination laid down in B.R. 155/1936, Article 543 (H).

(349/28/83.)

150.

PERSONNEL SERVING AT NORTHERN BASES.

With reference to paragraph 2 of Navy Order 43 of 1940, copies of reports of medical examinations are to be forwarded to the Naval Officer-in-Charge, Flinders Naval Depot.

(527/203/749.)

151.

AMMUNITION—20-MM. OERLIKON—CLEARING CHARGES.

The following is an advance copy of Admiralty Fleet Order 581/44 which has not yet been promulgated on the Australia Station:—

"(Part 1, G.0186/43—3rd February, 1944.)

The 20-mm. Oerlikon clearing charges, Mark I, referred to in Admiralty Fleet Order 4076/43 are to be used only in British, Mark II, III and III*, barrels. They are *not* to be used in American Barrels.

2. A clearing charge that can be used in any barrel is in production. Its advent will be announced by A.F.O.

3. D.E.M.S. staff officers should inform merchant ships".
(A.F.O. 4076/43.)"

(471/201/1446.)

152:

AMMUNITION—MISCELLANEOUS A.A.D. WEAPONS—TAILS, PROPELLING ROCKETS U 2-IN., MARKS II AND III, FILLED, KIRBY, LOTS 32, 33, 136, 178, 179 AND 182—RESTRICTION.

The following is an advance copy of Admiralty Fleet Order 583/44 which has not yet been promulgated on the Australia Station:—

"Owing to failures in service, tails, propelling rocket, 2-in., Marks II and III, Kirby, Lots Nos. 32, 33, 136, 178, 179 and 182, filled SU/D, are not to be issued. Any ammunition of these lots already issued should be withdrawn."

(471/208/1106.)

153.

FUZES TIME NO. 401 MARKS I AND IA.

Pending further instructions, no further issues of fuzes time No. 401 Mks. I and IA are to be made.

2. H.M.A. Ships, R.A.N. Armament Depots and ports at which stocks of Naval Armament stores are held are requested to forward to Navy Office early reports showing the quantities of fuzes time No. 401 Mks. I and/or IA held.

3. These instructions do not apply to fuzes time No. 401 Mark II or No. 401c Mark I.

4. Future weekly stock reports rendered in accordance with Navy Order 190 of 1942 are to distinguish the different marks of fuzes time No. 401, the next report rendered to show complete stocks of each mark.

(471/209/1321.)

154

ISSUE OF FREE KITS TO RATINGS ON ENTRY.

The attention of Accountant Officers is specially drawn to Consolidated Orders and Regulations, Article 463, clauses 2 and 3, strict compliance with which has not invariably been observed hitherto.

(516/301/651.)

155.

TORPEDO IGNITERS, MARK XI, LOT NO. 217, FILLED B.R. 12/41— WITHDRAWAL.

The following is an advance copy of Admiralty Fleet Order 436/44 which has not yet been promulgated on the Australia Station:—

“(A.S. 11698/43—27th January, 1944.)

Igniters, Torpedo, Mark XI of Lot No. 217, filled B.R. 12/41, are to be withdrawn from service.

2. Any igniters, torpedo, of this lot number on board H.M. Ships are to be landed at the nearest naval armament depot and others drawn in lieu.

3. Naval Armament Depots.—Igniters, torpedo, Mark XI, of Lot No. 217, filled B.R. 12/41, in store, together with any received from H.M. Ships, are to be emptied, certified free from explosive, and forwarded to S.A.S.O., Priddy's Hard”.

(666/206/1554.)

RESTRICTED.(FOR OFFICIAL USE ONLY.)

Commonwealth Navy Orders.

Navy Office, Melbourne,

4th April, 1944.

The following Orders, having been approved, are hereby promulgated for information and guidance and necessary action.

By direction of the Naval Board,

J. P. Macarandee
Secretary.

*The Rear-Admiral Commanding H.M.A. Squadron,
and Commanding Officers of H.M.A. Ships,
Officers in Charge of H.M.A. Naval
Establishments, and others concerned.*

TABLE OF CONTENTS.

No.	Subject.
156.	Higher Educational Test, October, 1943—Results.
157.	Service Personnel Overseas—Passports for Wives or Fiances.
158.	R.M.S. Personnel for Service Afloat.
159.	W.R.A.N.S.—Drafting.
160.	Admission of Naval Personnel to Mental Hospitals or Receiving Houses.
161.	Fire-fighting Equipment Trials—Reports.
162.	Motor Launches—Engine Register.
163.	Bofors Guns—Care and Maintenance.
164.	Clips Cartridge No. 25.—Reeving of Becketts.
165.	Depth Charges—Plugs Wood, Primer-tube, Stamp No. 6053.
166.	Ammunition Stock Reports.
167.	Stores Consigned by Sea or Air Freight to Northern Operational Bases.
168.	Office Machines—Method of Packing.
169.	Bedding for W.R.A.N.S.
170.	Issue of Mess Gear and Blankets to Personnel Travelling.
171.	Uniform and Clothing Supplies—Repayment Issues of Materials

HIGHER EDUCATIONAL TEST, OCTOBER, 1943—RESULTS.

The pass results obtained by candidates in the subjects taken by them in the Higher Educational Test held between the 19th and 22nd October, 1943, are as given hereunder. Included in these results are the pass marks obtained by each candidate at previous examinations where such marks are higher than those obtained at the October, 1943, examination.

Name.	Rating.	Official No.	Where Serving at Time of Examination.	Papers.									Remarks.
				I.	IA.	II.	III.	IV.	VII.	VIIA.	VIII.	IX.	
				General Knowledge.	English for A/Superintendent.	English History.	Geography.	Navigation.	Practical Mathematics.	Maths. for A/Pay, Superintendent.	Mechanics.	Merged in and Electricity.	
Behm, Patrick J. ..	Able Seaman (Radar) ..	B/3551 ..	<i>Arunta</i> ..	75	..	58	Awarded H.E. Certificate, 2nd Class
Little, Geoffrey B. ..	Able Seaman ..	PA/3002	56	56(<i>uu</i>)	91(<i>uu</i>)	75(<i>uu</i>)	
Ross, Bryan U.	PM/4051	64(<i>uu</i>)	93(<i>uu</i>)	Qualified for Warrant Rank and H.E. Certificate, 2nd Class
Rutherford, Ray A. ..	Petty Officer ..	21826	56	
Wardell, John R.	18900	63(<i>ss</i>)	..	61(<i>tt</i>)	..	65(<i>uu</i>)	96(<i>tt</i>)	Qualified for Warrant Rank and H.E. Certificate, 2nd Class
Dummett, Gordon ..	E.R.A., 4th Class ..	23388 ..	<i>Australia</i>	58	
Greaves, Laurence M. ..	Mech., 1st Class ..	20403	66(<i>ss</i>)	100(<i>rr</i>)	..	92	..	Qualified for Warrant Rank and H.E. Certificate, 2nd Class
Harriss, Wilfred L. ..	P.O. Tel. ..	20837	69	..	61	
Murray, Frederick M. ..	Yeo. of Sigs. ..	20100	70(<i>tt</i>)	77	80(<i>mm</i>)	Qualified for Warrant Rank and H.E. Certificate, 2nd Class
McIntosh, Charles I. ..	Mech., 2nd Class ..	20536	70	66(<i>tt</i>)	..	83(<i>ss</i>)	..	81(<i>uu</i>)	..	
Rainbow, George R. ..	E.R.A., 3rd Class ..	23380	68	63(<i>uu</i>)	..	92(<i>uu</i>)	..	04(<i>uu</i>)	..	Qualified for Warrant Rank and H.E. Certificate, 2nd Class
Symons, Leonard ..	Mech., 2nd Class ..	20535	83(<i>tt</i>)	..	87	..	
Caston, Joseph M. ..	E.R.A., 3rd Class ..	F/3271 ..	<i>Geraldton</i> ..	58	78	..	82	..	Awarded H.E. Certificate, 2nd Class
Impey, Ronald S. ..	A/Petty Officer ..	22381 ..	<i>Kapunda</i> ..	70	..	63	..	64	
Clarke, Frank ..	E.R.A., 3rd Class ..	22884 ..	<i>Magnetic</i>	58	Awarded H.E. Certificate, 2nd Class
Fisk, Thomas H. ..	Petty Officer ..	19948 ..	<i>Melville</i> ..	64	..	79	79	..	69	
Hare, John M. ..	P.O. Writer ..	23082	80	..	69	70	90(<i>uu</i>)	Awarded H.E. Certificate, 2nd Class
Huxley, Noel K. ..	Ch. E.R.A. ..	20227	59	
Mead, David D. ..	E.R.A., 3rd Class ..	22126	50(<i>rr</i>)	61	..	75(<i>nn</i>)	Qualified for Warrant Rank
Jerrett, Claude V. ..	S.B.P.O. ..	20379 ..	<i>Penguin</i>	58	71	
Stickney, Ralph E. ..	A/Ldg. Seaman ..	21596 ..	<i>Pirie</i> ..	55	Qualified for Warrant Rank
Williams, Patrick Y. ..	Petty Officer ..	21527 ..	<i>Rushcutter</i>	70	62	
Selman, John R. ..	P.O. Writer ..	PM/2047 ..	<i>Westralia</i> ..	81	..	78	75	Qualified for Warrant Rank
Gadaden, Neville E. ..	Ldg. Writer ..	S/3234 ..	<i>Thursday Is.</i>	56	76	

(*mm*) Marks obtained at March, 1939, examination.
 (*rr*) Marks obtained at October, 1941, examination.
 (*tt*) Marks obtained at October, 1942, examination.

(*nn*) Marks obtained at October, 1939, examination.
 (*ss*) Marks obtained at April, 1942, examination.
 (*uu*) Marks obtained at April, 1943, examination.

Maximum marks in each subject—100.
 75 per cent. of total marks is considered a first-class pass.
 55 per cent. of total marks is considered a second-class pass.

2. The marks obtained by candidates in subjects in which they did not pass are not shown above. Should any candidate desire to be informed of these marks, he should make application to the Commanding Officer of the ship or establishment in which he is serving, who has been supplied with a statement of the full results obtained at the examination. Notation of the award of Higher Educational Certificates and qualified for Warrant Rank (Q.W.R.) should be made on the Service Certificates of the ratings concerned.

(This Order will be reprinted for posting on Notice Boards.)

(465/204/667.)

157.

**SERVICE PERSONNEL OVERSEAS—PASSPORTS FOR WIVES
OR FIANCEES.**

It is Government policy not to grant passports to wives of members of the Services abroad to enable them to leave Australia to join their husbands; similarly, fiancées of members of the Services abroad will not be granted passports to leave Australia for the purpose of marrying.

(2030/2/39.)

(This Order will be reprinted for posting on Notice Boards.)

158.

R.M.S. PERSONNEL FOR SERVICE AFLOAT.

All Senior and Junior Reserve Officers and Engineer Officers, who pass through Flinders Naval Depot, will receive instruction in the identification and rendering safe of Japanese bombs and fuzes, during their Torpedo Course, and will thus be able to advise their Commanding Officers in these matters, during their service afloat.

2. Navy Order 226 of 1943 is cancelled.

(549/201/139.)

159.

W.R.A.N.S.—DRAFTING.

The Naval Officer-in-Charge, Flinders Naval Depot, has been constituted as the authority for the drafting of W.R.A.N.S. ratings.

2. A pool of W.R.A.N.S. ratings for drafting purposes is not borne at Flinders Naval Depot and the drafting of W.R.A.N.S. ratings between Establishments will only be effected for compassionate, medical or special Service reasons.

3. All applications in connexion with the drafting of W.R.A.N.S. ratings are to be forwarded to the Naval Officer-in-Charge, Flinders Naval Depot.

(432/224/2304.)

160.

**ADMISSION OF NAVAL PERSONNEL TO MENTAL HOSPITALS OR
RECEIVING HOUSES.**

On every occasion when any member of the Naval Forces is admitted to a Receiving House or to a Mental Hospital, steps are to be taken by the Commanding Officer of the Ship or Establishment on whose books the patient is borne to inform the next of kin immediately.

2. The letter or signal should state that the member in question has been admitted to (state where) on (give date) for investigation and treatment, and that further details will be given when available.

(527/201/897.)

161.

FIRE-FIGHTING EQUIPMENT TRIALS—REPORTS.

Attention is drawn to A.F.O. 5771/43, the provisions of which are to apply to H.M.A. Ships.

2. Principal Naval Overseers are to ensure that a fire-fighting equipment trial is included in trial programmes of ships building and refitting under their supervision.

(475/202/514.)

162.

MOTOR LAUNCHES—ENGINE REGISTER.

The instructions given in Navy Order 386 of 1943, paragraph 1, sub-paragraph (1), regarding the completion of Form S.1501A—Daily Engine Room Register, are to be modified by deletion of the words "at sea." A copy of this form is to be completed *every* day in order that full records are kept of work done, and changes of oil, &c., for days when the boat is not at sea.

2. The attention of Base Engineer Officers is directed to the importance of regular examination of these Engine Room Registers to ensure that routine maintenance is being properly carried out.

3. The Engine Register S.1501 is to be signed by the Base Engineer Officer when produced weekly in accordance with paragraph 2 of Navy Order 386 of 1943.

(480/202/4356.)

BOFORS GUNS—CARE AND MAINTENANCE.

The following Maintenance Routine should be carried out with all Bofors Guns mounted:—

Part of Gun.	Maintenance Routine and Lubricant to be Used.	How Often.
Barrel— Inside	Dry Piasaba brush followed by a slightly oily rag over a mop If possible, change barrel and fill with hot water and use Piasaba brush followed by a slightly oily rag over a mop Graphited Grease Z.E. ..	Daily or, in damp conditions, more often After firing
Interrupted threads ..	Graphited Grease Z.E. ..	Weekly or when barrels are changed
Breech Block	Dismantle, and lubricate with White Lubricant Special	Every other day and after firing
Breech Ring— Nipples 1, 2, 3, 4 ..	Lubricate with Oil Colloidal Graphited Z.A.	Weekly (if conditions allow)
Breech Casing ..	Clean with G.S. Mineral Oil	Two or three times weekly
Auto Loader— Frictional parts ..	Clean, and lubricate with White Lubricant Special	} Weekly and after firing
Non-frictional parts ..	Clean, and lubricate with G.S. Mineral Oil	
Mounting— Elevating and traversing gears	Lubricate with Admiralty Compound Oil	Weekly
Forced feed nipples ..	Lubricate with Admiralty Compound Oil	As required, periodically
Recuperator spring ..	Clean, and lubricate with Mineral Jelly	As required, periodically

NOTE.—In cold weather—

- (i) Oil D.T.D.44d should be substituted for G.S. Mineral Oil and for Admiralty Compound Oil.
- (ii) Graphited Grease Z.E., Oil Colloidal Graphited Z.A. and Mineral Jelly should be thinned with Oil D.T.D.44d.

(490/212/1060.)

CLIPS CARTRIDGE No. 25—REEVING OF BECKETS.

Difficulty has been experienced in removing Clips Cartridge No. 25 from cartridges.

2. If the becketts of the clips are assembled by reeving the becket through the slot from the inside of the clip so that the double portion of the becket remains on the inside, this difficulty will not occur.

3. Ships are to modify the clips on ammunition held on board.

4. Depots are to carry out this modification when cartridges are passing through laboratories for overhaul, repair, &c.

(408/207/2240.)

DEPTH CHARGES—PLUGS WOOD, PRIMER-TUBE, STAMP No. 6053.

With reference to Admiralty Fleet Order 1214/43, whenever depth charges are received on board H.M.A. ships, the wooden plugs, primer-tube, Stamp No. 6053 and bolts, complete with nuts and washers, Stamp No. 6012, which are always to be supplied with the charges, are to be retained on board.

2. (a) Although not accounted for separately, these stores are always to be preserved in good condition and when not actually in use should be stowed accordingly.

(b) The plugs, complete with bolts, nuts and washers are always to be fitted when depth charges are landed or transferred.

(c) Plugs and associated stores remaining on board from expended depth charges are to be returned to the nearest Naval Armament Depot at the first opportunity.

3. When depth charges are unfitted and/or unprimed, the primer tube should be closed by means of these plugs to prevent the entry of water and foreign matter.

4. Demands to make good deficiencies should be forwarded to the nearest Naval Armament Depot or base.

5. Attention is drawn to O.U.5485, paragraphs 45 and 46.

(471/205/2105.)

AMMUNITION STOCK REPORTS.

With reference to Navy Order 190 of 1942, the marks of the following items are to be reported in future weekly stock statements:—

Fuses percussion D.A. No. 230.

Cartridges signal 1½" double star.

2. Cartridges signal 1" red are to be reported under the following descriptions:—

Cartridges signal 1" red Mark XII.

Cartridges signal 1" red other than Mark XII.

3. The next report rendered is to include total stocks of each of the above items.

(612/202/2989.)

STORES CONSIGNED BY SEA OR AIR FREIGHT TO NORTHERN OPERATIONAL BASES.

Owing to the frequent losses, delays and inconvenience which have been experienced in connexion with stores consigned to forward areas, all R.A.N. cased packages, also bales where practicable, forwarded from Store Establishments to such destinations for delivery either to H.M.A. Ships or shore bases are, in future, in addition to the usual markings to indicate addressee and port of destination, to be legibly stencilled in appropriate paint with the brand AUST. NAVY on all sides of the package.

2. Loose or bundled articles are, according to their nature, also to be suitably branded in a similar manner, in paint where possible, or to have securely attached a metal tally 3 inches by 2 inches in dimensions, with the lettering "AUST. NAVY" clearly stamped thereon.

3. Such letters are to be up to 6 inches in height for large cases and bales, being reduced in size as necessary for medium and small packages, the main object being to ensure quick delivery and ready identification as between Allied Forces at port of destination. In the case of very small packages, metal tallies will suffice.

4. The words "forward areas" in paragraph 1 above are intended to include Darwin and Thursday Island, as well as New Guinea bases and other northern operational areas.

5. Navy Order 320 of 1943, relating to the special marking of packages consigned to Port Moresby, is hereby cancelled, as future packages for that destination are to have the normal distinctive colour bands specified in C.O.R., Article 526, clause 10.

(1990/2/692.)

168.

OFFICE MACHINES—METHOD OF PACKING

Attention is invited to A.F.O. 5804/1943 as unnecessary damage to typewriters, &c., returned to Naval Store Depots has been caused through faulty packing.

(524/209/767.)

169.

BEDDING FOR W.R.A.N.S.

The approved allowances of Bedding for W.R.A.N.S. (Officers and Ratings) occupying Service accommodation are those indicated in A.F.O's. 1483/42 and 6071/42 modified as follows:—

Item.	R.N. Allowance as per A.F.O's.	R.A.N. Allowance.
Counterpanes ..	1 No. per Officer, plus 10% spare	Nil
Coverlets ..	1 No. per Rating, plus 10% spare	Nil
Towels, hand ..	2 No. per Officer	Nil
	2 No. per Rating	
Blankets ..	4 No. per Officer	4 No. per Officer 3 No. per Rating (to be reduced to 2 No. each in tropical areas)
	3 No. per Officer	
Sheets ..	4 No. per Officer	3 No. per person
	3 No. per Rating	
Pillow Covers ..	4 No. per Officer	2 No. per person
	3 No. per Rating	

(612/235/860.)

170.

ISSUE OF MESS GEAR AND BLANKETS TO PERSONNEL TRAVELLING.

The following arrangements for the issue of mess gear to personnel travelling by troop train and road transport throughout the Commonwealth are to be instituted as soon as practicable:—

- (a) *Between Melbourne, Sydney and Brisbane.*—It is not necessary for loan issues to be made to personnel travelling between these points.
- (b) *On Other Routes.*—Personnel are required to be in possession of mess gear when travelling—
- (i) Between Adelaide and Perth by troop train;
 - (ii) between Adelaide and Darwin by troop train and road transport;
 - (iii) between Melbourne and Adelaide by troop train;
 - (iv) north of Brisbane by troop train; and
 - (v) between Townsville and Darwin by troop train and road transport.

2. Arrangements have been made with the New South Wales Railways Department to issue cutlery to Naval personnel travelling by rail in that State. To ensure that issues are properly accounted for, the following instructions are to be incorporated in orders issued by the Railway Transport Officers at Sydney, Melbourne and Brisbane to officers or ratings in charge of drafts travelling between Melbourne, Sydney and Brisbane:—

Issue of Mess Gear.—On arrival at troop train feeding points between Melbourne and Brisbane, the officer or rating in charge of personnel is to carry out the following procedure:—

- (i) Report to manager of the railway refreshment room for issue of the required number of knives, forks and spoons; give attached receipt to manager, railway refreshment room, as having received same, and arrange the issue of cutlery to personnel.
- (ii) Arrange for collection of cutlery on completion of meal, and obtain a clearance for return of same from manager, railway refreshment room, on applicable certificate hereunder.
- (iii) Any shortage to be immediately investigated and instructions issued to the rating/s responsible for the loss to report to the Railway Transport Officer at the next capital city immediately on arrival."

3. Requests for the supply of mess gear, as per the following *pro forma* at (a), are to be made at each refreshment room, and separate receipts for the return of cutlery are to be obtained, as in *pro forma* (b), from the managers of refreshment rooms at which meals are taken:—

(a) The Manager,

R.R.R.....

Please supply for use to Naval personnel.....
knives..... forks..... spoons for use at
meal on.....

Receipt of these articles which will be returned on
completion of meal, is hereby acknowledged.

.....
O.C.R.A.N. Draft.

(b) It is certified that cutlery issued to Naval personnel for
meal on..... has been returned, *with the
exception of the following:—*

Short returned.

Knives
Forks
Spoons

(NOTE.—Delete italicized portion as necessary.)

.....
Manager, R.R.R.

Date.....

4. Losses of mess gear and blankets by personnel travelling between Melbourne, Sydney and Brisbane, are to be dealt with on Form A.S.126—Stores lost by Neglect—which is to be prepared in quintuplicate by the Railway Transport Officer to whom the draft reports on completion of the journey. Form A.S.126 is to be forwarded in triplicate to the Ship or Establishment to which the officer or rating responsible for the loss is proceeding, the quadruplicate copy to the Railway Transport Officer, Sydney, and the quintuplicate retained by the Railway Transport Officer preparing the form.

5. The rates to be charged for mess gear and blankets lost by neglect are:—

			s.	d.	
Knives, table	2	2	each
Forks, table	1	0	each
Spoons, dessert	0	10	each
Pannikins, tin	0	8	each
Plates, tin	0	6	each
Blankets, loan	17	4	each

Any variation in these rates will be promulgated in Navy Orders from time to time.

6. The issue and collection of mess gear at Melbourne, Perth, Adelaide and Townsville will be made by the respective Railway Transport Officers. At Darwin and Cairns, the respective Naval Officers-in-Charge will make necessary local arrangements.

7. The issue of mess gear to personnel travelling northward from Brisbane by troop train, and the collection of such gear from personnel arriving at Brisbane by troop train from Townsville, Cairns or Darwin, irrespective of their final destination, is the responsibility of the Commanding Officer, H.M.A.S. *Moreton*.

8. The Railway Transport Officer at Melbourne is to issue mess gear to all personnel leaving Melbourne for Adelaide, Perth or Darwin (via Adelaide) by troop train, and be responsible for the collection of mess gear from all personnel arriving in Melbourne, via Adelaide. (E.g.—Personnel proceeding from Fremantle to Townsville, via Brisbane will be issued with gear at Perth. Gear will be handed in on arrival at Melbourne, and a further issue made at Brisbane before departure to Townsville.)

9. Form A.T.801z (in triplicate) has been introduced for the purpose of recording all issues made by Railway Transport Officers, and provides for suitable entries to be made of the name of the officer or rating, signature of each member of the draft, and details of the items issued. First supplies of these forms will be distributed by the Superintending Naval Store Officer, Sydney, without demand and subsequent requirements are to be obtained from that source.

10. Where drafts for more than one destination are travelling on the same train, separate Forms A.T.801z are to be prepared by the responsible Railway Transport Officer for each draft. The original and duplicate copies are to be given to the officer or senior rating in charge of the draft, for delivery to the Railway Transport Officer responsible for the collection of the gear, with necessary instructions to ensure that the forms are handed to the Railway Transport Officer immediately on arrival at the point where the gear is to be collected. The triplicate copy is to be retained by the issuing Railway Transport Officer.

11. The receiving Railway Transport Officer is to check all items handed in against issues recorded on Form A.T.801z, receipt the duplicate copy and return it to the issuing Railway Transport Officer. All cases of failure to return gear are to be promptly investigated, and any discrepancies noted on the back of the form in accordance with the printed instructions shown at the foot of the duplicate copy.

12. In cases of losses by neglect, Form A.S.126 is to be prepared by the receiving Railway Transport Officer in quadruplicate. Three copies are to be forwarded to the Accountant Officer of the Ship or Establishment to which the officer or rating is appointed or drafted, and the quadruplicate copy retained.

13. In cases where personnel are diverted to a destination other than that originally intended, or where personnel travel to an intermediate station at which a Naval Railway Transport Officer is not established, the following procedure is to be followed:—

(i) "*Diverted Personnel*.—The Railway Transport Officer at the point where the diversion occurs is to obtain from the officer or rating in charge of the draft, the Form A.T.801z prepared by the issuing Railway Transport

Officer, amend it as necessary in respect of the personnel diverted and notify the issuing Railway Transport Officer accordingly. A new Form A.T.801z is then to be prepared in respect of the gear held by personnel diverted, and forwarded to their ultimate destination. (e.g., where a portion of a draft travelling from Melbourne to Fremantle is diverted on arrival at Adelaide, to Darwin, the Railway Transport Officer at Adelaide is to amend Form A.T.801z prepared by Railway Transport Officer, Melbourne, by endorsing both copies with a note that the personnel have been diverted. The new form is to be forwarded to Naval Officer-in-Charge, Darwin, and Railway Transport Officer, Melbourne, informed accordingly.)

- (ii) *Personnel Travelling to Intermediate Stations.*—In cases of issuing gear to personnel travelling on leave to intermediate stations such as Kalgoorlie, such personnel are not to be included in Form A.T.801z, but are to sign separate receipts for gear issued, and instructed to retain such gear whilst on leave and return it to the issuing Railway Transport Officer on their return."

14. Each Railway Transport Officer is to maintain a record of issues and receipts of loan gear, which is to be forwarded monthly to the Accountant Officer of the Establishment to which he is attached.

15. The issue of blankets is to be made by Railway Transport Officers to personnel travelling on any route where considered necessary. Such issues are to be made in accordance with the procedure outlined above.

(530/201/531.)

171.

UNIFORM AND CLOTHING SUPPLIES—REPAYMENT ISSUES OF MATERIALS.

In view of the provisions of Navy Orders 390 and 674 of 1943, C.O.R., Article 473, is suspended pending further notice.

(433/201/813.)

By Authority: H. E. Daw, Government Printer, Melbourne.

RESTRICTED.

(FOR OFFICIAL USE ONLY.)

Commonwealth Navy Orders.

Navy Office, Melbourne,

11th April, 1944.

The following Orders, having been approved, are hereby promulgated for information and guidance, and necessary action.

By direction of the Naval Board,

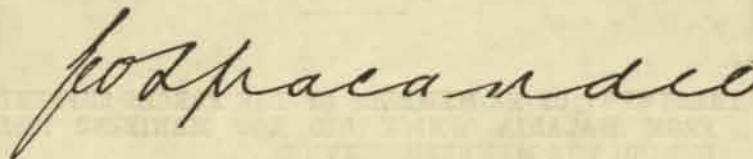

Secretary.

*The Rear-Admiral Commanding H.M.A. Squadron,
and Commanding Officers of H.M.A. Ships,
Officers in Charge of H.M.A. Naval
Establishments, and others concerned.*

TABLE OF CONTENTS.

No.	Subject.
172.	Junior Writer and Supply Ratings—Typewriting Experience.
173.	Treatment of Ex-Members of the Forces Suffering from Malaria which Did Not Manifest Itself During the Member's Service.
174.	Naval Officer-in-Charge, Brisbane—Correspondence on Naval Armament Store Matters.
175.	Royal Australian Nursing Service—Wearing of Shoulder Straps.
176.	Allocation of R.A.N.V.R. Able Seamen to General Service.
177.	Naval Censorship.
178.	H.M.A. Ships Maintenance of Upper Deck Fittings.
179.	20 M.M. Oerlikon Guns—Locking of Barrels.
180.	Cordite—Landing.
181.	Accumulators—Abnormal Expenditure.
182.	Steel Chests for A.M.S. Vessels.
183.	Clothes Rationing—Bed Linen.
184.	Compensation for Loss of Tools.
185.	Books and Forms.
186.	Printed Forms.
187.	Expenditure on Behalf of Netherlands—Classification.

C.3552/44.

172.

JUNIOR WRITER AND SUPPLY RATINGS—TYPEWRITING EXPERIENCE.

In consequence of the employment of W.R.A.N.S. Typistes in Shore Establishments, it has become the practice for these ratings to carry out all the typing work of the Establishment, with the result that junior Writer and Supply ratings obtain no typing experience, so that, when drafted to Ships or Northern Bases where no W.R.A.N.S. are carried, they are incapable of carrying out the typing duties required of them.

2. To overcome this difficulty, all Writer and Supply ratings in Shore Establishments where W.R.A.N.S. are borne, are, if below Leading rate, to be given instruction in typing for at least one half-hour per week, with an additional one and a half hours' practice, until the Accountant Officer is satisfied that they are capable of typing at the rate of at least twenty-five words per minute.

(432/224/2360.)

173.

TREATMENT OF EX-MEMBERS OF THE FORCES SUFFERING FROM MALARIA WHICH DID NOT MANIFEST ITSELF DURING THE MEMBER'S SERVICE.

Where malaria becomes manifest after the discharge of a member of the Naval Forces to civil life, it is imperative that treatment should be carried out at the earliest possible date.

2. The Repatriation Commission will provide treatment subject to the identity of the ex-member being satisfactorily established by the production of his Certificate of Service or other suitable documents (see paragraph 6). The question of attributability to service will be dealt with at a later period.

3. Any discharged member of the Naval Forces in whom malaria becomes manifest should apply immediately to the nearest Deputy Commissioner of Repatriation or Repatriation Medical Officer for treatment.

4. If this is not practicable, treatment should be sought from a civil medical practitioner or civil hospital. The ex-member is in such cases to ensure that steps are taken to notify the Deputy Commissioner, Repatriation Commission, of the State in which he is under treatment, that he is receiving anti-malarial treatment.

5. All members of the Naval Forces are to be informed of the purport of the foregoing paragraphs prior to discharge, whether such discharge is on medical grounds or for other reasons.

6. In addition, every member, who has suffered from malaria while in the Naval Forces, is to be given a copy of his record of treatment for this disease, to which he is to affix his signature for purposes of identification.

(This Order will be reprinted for posting on Notice Boards.)

(527/211/2005.)

174.

NAVAL OFFICER-IN-CHARGE, BRISBANE—CORRESPONDENCE ON NAVAL ARMAMENT STORE MATTERS.

All Ships and Establishments are informed that correspondence with Brisbane relating to Naval Armament Stores should be addressed to the Naval Officer-in-Charge and not to the Commanding Officer, H.M.A.S. *Moreton*.

(443/201/1285.)

175.

ROYAL AUSTRALIAN NAVAL NURSING SERVICE—WEARING OF SHOULDER STRAPS.

On all occasions when the wearing of Capes is impracticable, Members of the Royal Australian Naval Nursing Service may, subject to the approval of the Commanding Officer of the Establishment in which they are serving, wear shoulder straps on their uniforms.

(516/201/628.)

176.

ALLOCATION OF R.A.N.V.R. ABLE SEAMEN TO GENERAL SERVICE.

Applications are invited from Able Seamen, R.A.N.V.R., who were entered for shore service only, to volunteer for General Service. Subject to their being recommended, volunteers for General Service will be accepted provided that they—

- (a) Are up to the normal medical standard for entry in the Seaman Branch of the R.A.N.R.
- (b) Are under the age of forty-five.
- (c) Sign an undertaking, which would be witnessed by a Commissioned Naval Officer, volunteering for Active or any Naval Service.

2. Lists of recommended volunteers are to be forwarded to the Secretary of the Naval Board, copy to the Naval Officer-in-Charge, Flinders Naval Depot. These should be rendered by 1st May, 1944. Names of any volunteers who come forward subsequently may be submitted on a monthly Return addressed to the Secretary, Naval Board, copy to Naval Officer-in-Charge, Flinders Naval Depot.

3. Statements volunteering for General Service, paragraph 1 (c), above, are to accompany the Returns forwarded to Navy Office. These statements will be attached to the rating's Engagement Forms.

4. Ratings whose names are reported will be drafted to Flinders Naval Depot, as convenient, for New Entry Course. On successful completion of the Course, ratings will be noted as available for appropriation for General Service, and in all Service documents will thereafter be described as R.A.N.V.R.(S). The notation (S) should be made immediately on successful completion of the New Entry Course.

5. Ratings who are found to be unsuitable for General Service may be withdrawn from the Course at any time and will be retained for Base Staff duties so long as their services are required.

6. Able Seaman, R.A.N.V.R.(S), will be eligible for advancement on qualifying in accordance with Regulations applicable to the General Service; previous service in the R.A.N.V.R. will be allowed to reckon for advancement purposes.

(432/203/1318.)

(This Order will be reprinted for posting on Notice Boards.)

177.

NAVAL CENSORSHIP.

Paragraph 14 of Navy Order 23 of 1944—Naval Censorship—is cancelled, and the following paragraph is substituted in its stead:—

“14. In ships giving regular leave in Australia, South of Latitude 20°S., censorship may be suspended at the discretion of the Commanding Officer as soon as regular leave commences. When censorship has been suspended, the posting of mail or the dispatch of telegrams on shore is permitted, but it is an offence to divulge in such communications any information which would not be passed by the ship's censor, other than the writer's location as disclosed by the postmark on mail posted ashore. No mention is to be made of the location of the ship. When censorship has been suspended advice is to be signalled to Naval Board repeated to Naval Officers-in-Charge, Fremantle, Port Adelaide, Port Melbourne, Hobart, Sydney, Newcastle, Brisbane and Townsville so that District Censors may be informed. The same authorities are to be advised when the censorship is reimposed. Upon receipt of information that censorship has been suspended or reimposed, each of the above Naval Officers-in-Charge is immediately to inform the District Censor in his area.”

(1835/2/534.)

178.

H.M.A. SHIPS—MAINTENANCE OF UPPER DECK FITTINGS.

It has been reported from refitting authorities that in some ships, especially A.M.S. Vessels, the standard of maintenance of upper deck fittings leaves much to be desired, and consequently unnecessary additional refitting work is required from Dockyards.

2. Items which are commonly found rusted and seized due to lack of regular maintenance and lubrication are:—

- Dropnose pins and hinge bolts in hinged davits.
- Brackets and footstep bearings of small davits.
- Fairlead rollers, sheaves, &c.
- Butterfly nuts on hatch covers and lockers.
- Rollers on cowls.
- Guardrail shackle pins.
- Hinged guardrail stanchions.

3. Steel decks and steel wire rope also require more attention.

(603/267/1481.)

179.

20 M.M. OERLIKON GUNS—LOCKING OF BARRELS.

Owing to the loss of Oerlikon Barrels due to incorrect locking, the following action is approved:—

2. *Material.*—All Oerlikon Barrels are to be scribed circumferentially with two lines on the barrel to indicate the positions of the forward edge of the Barrel Spring Case in the Cocked and Uncocked positions. This work is to be carried out by Ships Artificers or Base Staffs if no O.A.'s are borne, the barrels being first securely locked to the cradle. Guns in store are to be modified by Depot Artificers.

3. *Drill.*—The following amendments are to be made to B.R.274/41:—

(a) Page 16. After 1 reports “Bore Clear” insert:—

“and sees that the barrel is home by noting that the forward edge of the Barrel Spring Case is in line with the appropriate engraving on the Barrel, and that the Barrel Locking Lever is right down in the Locked position.”

(490/212/987.)

180.

CORDITE—LANDING.

The procedure of withdrawing cordite by a monthly Navy Order is being discontinued.

2. The withdrawal of cordite from H.M.A. Ships and Auxiliary Vessels is now to be effected in accordance with relevant Admiralty Fleet Orders.

3. Paragraph 1 of Navy Order 241 of 1940 is cancelled.

(471/202/1398.)

181.

ACCUMULATORS—ABNORMAL EXPENDITURE.

It is observed that demands for replacement of Accumulators for H.M.A. Ships and Establishments have increased considerably in recent months.

2. Accumulators are in extremely short supply and it is desired that demands for such items should be reduced to a minimum.

3. Particular attention is to be given to the maintenance of Accumulators to ensure maximum service.

(612/217/1474.)

182.

STEEL CHESTS FOR A.M.S. VESSELS.

With reference to Navy Order 417 of 1943, approval has been given to increase the allowance of Pattern 1477 Light Steel Chests for the stowage of confidential books and documents for A.M.S. Vessels from 3 No. to 4 No.

2. Supply of the additional Chest to all A.M.S. Vessels will be effected without demand by the Superintending Naval Store Officer, Sydney, as soon as stocks become available.

(544/201/308.)

183.

CLOTHES RATIONING—BED LINEN.

In consequence of the extension of civilian clothes rationing to include manchester goods, supplementary issues of clothes ration coupons to Naval personnel for the purpose of the provision and maintenance of bed linen have been approved as follows, and will operate forthwith:—

(i) *Officers entered or promoted subsequent to 5th June, 1943—Initial Provision.*

A "permit to purchase" bed linen up to a maximum ration value of 62 No. coupons, to cover three pairs of single bed sheets and 4 No. pillow cases, may be issued by the Deputy Directors of Rationing upon application by an officer so entitled through his Commanding Officer, to the appropriate Naval Officer-in-Charge of a capital city area. Such application should state actual requirements and measurements of bed sheets, and be accompanied by a signed statement indicating bed linen already in his possession. The coupon value of the "permit to purchase" will be assessed in accordance with such statement.

(ii) *Naval personnel serving prior to 5th June, 1943—Maintenance Provision.*

An annual maintenance issue of 5 No. coupons may be made forthwith to officers who were serving prior to 5th June, 1943. This special issue may be extended to officers and ratings (including Royal Australian Naval Nursing Service and Women's Royal Australian Naval Service) who are not accommodated in Service Quarters, provided that such personnel are required to maintain their own supplies of bed linen.

2. For the balance of the current rationing year only, this supplementary issue of 5 No. coupons need not be restricted to bed linen, but may be used for clothing, if desired.

3. Supplies of sheets of 5 No. coupons should be obtained in accordance with Navy Order 480 of 1943, Part I, paragraph 6, and issues recorded in accordance with paragraph 9 thereof. Returns are required at the end of the current rationing year only, viz., 4th June, 1944.

4. The currency of clothing coupon issues (printed in black) will expire on 4th June, 1944. Coupon issues (printed in red) will remain current until 31st December, 1944.

(612/235/851.)

184.

COMPENSATION FOR LOSS OF TOOLS.

The attention of all personnel concerned should be drawn to the instructions in A.F.O. 3406/43, relative to the payment of compensation in respect of losses of tools.

2. Compensation for the loss of tools included in a minimum tool kit is normally effected in accordance with K.R. and A.I., Article 1697. Compensation for private tools carried in excess of the minimum tool kit is paid only on the conditions indicated in A.F.O's 4661/40 and 3406/43, and ratings should be informed of the risk involved in keeping valuable private tools in excess of minimum tool kit on board H.M.A. Ships and in H.M.A. Naval Establishments. Particular attention should be drawn to the fact that compensation in such cases will only be allowed where there is direct evidence of loss.

(438/204/782.)

185.

BOOKS AND FORMS.

The under-mentioned publications have been distributed. Additional copies of B.R.155A and O.U.5365E are being obtained to complete distribution:—

B.R.155A/1943 (supersedes B.R.155 (1) 1939 and B.R.155A/1938).—Handbook for Breathing Apparatus, Pattern 230, Salvus Self-contained Breathing Apparatus.
(A.F.O.6051/43.)
(571/202/1768.)

B.R.268 (36).—Electrical Manual, Volume II—Main Electrical Supplies in Light Craft.
(A.F.O.5150/43.)
(571/202/1716.)

B.R.269/43 (supersedes B.R.'s 269, 197, and 199).—Handbook for 12 pdr. Gun on HA/LA IX, H.A. VIII, H.A. VIII*, and P.I. MOUNTINGS.
(A.F.O.4129/43.)
(571/202/1878.)

B.R.820/43.—The Provision of Safe Water for Drinking, Cooking, Washing and Similar Purposes.
(A.F.O.3867/43.)
(571/202/1811.)

B.R.860 (1) (late O.U.5491 (1)).—Block Sketch Cards of Foreign War Vessels (Germany)—New Card No. 24.
(A.F.O.3760/43, 4640/43.)
(571/203/2514.)

B.R.901/38 (late C.B.1886/38).—Handbook for Admiralty Fire Control Clock, Mark I.

- B.R.901/34 (1) (late C.B.1886/34 (1)).—Addendum No. 1 to above.
- B.R.901/34 (2) (late C.B.1886/34 (2)).—Addendum No. 2 to above.
- B.R.901/38 (4) (late C.B.1886/38 (4)).—Addendum No. 4 to above.
(A.F.O.4640/43.)
(571/202/1858.)
- B.R.902 (late C.B.4072).—Handbook for Admiralty Fire Control Clocks, Marks VII and VII*—1940.
(A.F.O.4640/43.)
(571/202/1859.)
- B.R.904_A (late C.B.1798_A).—Handbook for the Admiralty Fire Control Table, Mark II ("KENT" Class and later Cruisers), Book I—Text.
- B.R.904_A (1) (late C.B.1798_A (1)).—Addendum No. 1 to above.
- B.R.904_A (2) (late C.B.1798_A (2)).—Addendum No. 2 to above.
- B.R.904_B (late C.B.1798_B).—Handbook for the Admiralty Fire Control Table, Mark II ("KENT" Class and later Cruisers), Book II—Plates.
(A.F.O.4640/43.)
(571/202/1860.)
- B.R.905/37 (late C.B.1938/37).—Handbook of the Admiralty Fire Control Table, Mark V.
(A.F.O.4640/43.)
(571/202/1861.)
- B.R.908 (late C.B.4113).—Handbook for Augmenting Tables.
(A.F.O.4640/43.)
(571/202/1862.)
- B.R.917 (late C.B.4070).—Handbook for 4.5-in. Q.F., Mark I (N), III (N), Gunson Twin, Mark II B.D. and Mark III U.D. Mountings, 1940.
(A.F.O.4640/43.)
(571/202/1866.)
- B.R.920 (late C.B.3078).—Handbook for the Dame A.A. Teacher, 1942.
(A.F.O.4640/43.)
(571/202/1870.)
- B.R.921 (late C.B. 4085).—Handbook on the Multiple U.P. Equipment, Mark I (Apparatus A.D. Type B, Mark I, With Bomb A.A.D. No. 2, Mark I).
(A.F.O.4640/43.)
(571/202/1871.)

- B.R.924 (late C.B.3104).—Handbook for the 2-in. Rocket Flare and Projector, 1943.
(A.F.O.4640/43.)
(571/202/1865.)
- B.R.926 (late C.B.4145).—Handbook for the 3-in. U.P. Harvey Projector, Instructions for H.M. Ships.
(A.F.O.4640/43.)
(571/202/1872.)
- O.U.5292.—Block Sketch Cards of British Warships—Pages 5_A, 6, 12, 16, 17_A, 17_B, 19, 19_B, 24, 24_C, 24_D, 24_E, 28_B, 33_A, 35_B, 37_A, 37_B, 37_C, 38_B, 38_C, 38_D, 39_A, and 39_B.
(A.F.O.3760/43.)
Pages 37_A, 37_B, 37_C, 38_B, 38_C, 38_D, and 39_A.
(A.F.O.4507/43.)
(571/203/2354.)
- O.U.5365_E—Part V.—(Mining Stores) Priced Vocabulary of Naval Armament Stores—Revised Edition.
(A.F.O's 3351, 4507, and 5026/43.)
(571/203/2495.)
- Appendix to O.U.6254/34.—Training of Midshipmen—Standard Lectures on Ship Construction and Design.
(A.F.O.3456/42.)
(571/203/2431.)
- O.U.6353.—May, June and July Supplements, British Merchant Ships Lost.
- O.U.6353_A.—May, June and July Supplements, Foreign Merchant Ships Lost and Damaged by the Enemy.
(A.F.O's 3760 and 4507/43.)
(571/203/2460.)
- Anti-Aircraft Procedure Instructions—Additional Pages, Nos. 2, 4 and 5 to Amendment No. 1.
(571/201/3921.)
- A.P.1480_A.—Amendment No. 98, 99, 100, 102 and 103—Silhouettes of Aircraft (Royal Air Force).
- A.P.1480_B.—Amendment No. 35 and 36—Silhouettes of Aircraft (German).
- A.P.1480_C.—Amendment No. 23—Silhouettes of Aircraft (Italian).
- A.P.1480_F.—Amendment No. 16—Silhouettes of Aircraft (Japanese).
- A.P.1480_I.—Amendments No. 17, 18, 19—Silhouettes of Aircraft (American).

A.P.1480z/2.—Amendment No. 1, D.E.M.S. (Aircraft Recognition Handbook).

(A.F.O's 3760 and 4507/43.)
(571/201/3829.)

Q.1/M350.—Optimum Frequency Band Tables.

Q.2/M350.—Frequency Guide for the North and South Atlantic—November, December, 1943, and January, 1944.

Q.3/M350.—Frequency Guide for the Indian Ocean—November, &c.

Q.4/M350.—Frequency Guide for Shore-Ship communication in the Indian Ocean, November, &c.

(A.F.O.4139/43.)

R.2/M350.—Frequency Guide for the North and South Atlantic for February, March and April, 1944.

R.3/M350.—Frequency Guide for the Indian Ocean for February, &c.

R.4/M350.—Frequency Guide for Shore-Ship communication in the Indian Ocean for February, &c.

Recommended Frequency Bands for Aircraft in the Atlantic and Pacific—January, February, March, 1944.

Frequency Guide for Operating Personnel—January through June, 1944.

(A.F.O.5414/43.)
(571/202/1742.)

Aircraft Recognition Journal, Volume II, Nos. 2 and 3.

(415/201/1879.)

186.

PRINTED FORMS.

The under-mentioned form has been introduced for use in the R.A.N. in lieu of the corresponding Admiralty Forms 250A. Supplies will be issued on demand when stock of the existing form is exhausted:—

A.S.250A.—Station Bill.

(480/202/4513.)

2. The under-mentioned form has been revised and attention is drawn to the provisions of an additional (quadruplicate) copy for use as forwarding advice by the Consignor to the Consignee. Supply will be effected, on demand, when stock of the existing form is exhausted:—

A.S.559z.—Railway Consignment Note.

(480/202/4548.)

3. The under-mentioned form has been introduced for use in the R.A.N. First supply will be effected, without demand, by the Superintending Naval Store Officer, Sydney:—

A.T.810z.—Loan Issue Voucher for Items issued to Naval Personnel travelling by Rail.

(480/201/3261.)

187.

EXPENDITURE ON BEHALF OF NETHERLANDS— CLASSIFICATION.

A communication has been received from the Senior Naval Officer, Royal Netherlands Navy in Australia, inviting attention to the fact that the Royal Netherlands Navy is an entirely separate organization from the Netherlands East Indies Government and Netherlands East Indies Army and requesting that this information be circulated in order to clarify the position as regards any claims for supplies and services.

2. Netherlands expenditure should therefore be charged to the vote for "Other Administrations—Recoverable Expenditure (N.E.I.) or (R.N.N.)", as appropriate.

(434/201/3423.)

RESTRICTED.(FOR OFFICIAL USE ONLY.)**Commonwealth Navy Orders.**

Navy Office, Melbourne,
18th April, 1944.

The following Orders, having been approved, are hereby promulgated for information and guidance, and necessary action.

By direction of the Naval Board,

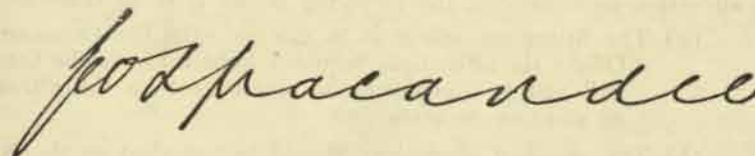

Secretary.

*The Rear-Admiral Commanding H.M.A. Squadron,
and Commanding Officers of H.M.A. Ships,
Officers in Charge of H.M.A. Naval
Establishments, and others concerned.*

TABLE OF CONTENTS.

No.	Subject.
188.	H.M.A.S. "Harman"—Commissioning.
189.	Quarter Bills—Amendments.
190.	R.N. Ratings on Loan to the R.A.N.—Disposal of Service Certificates on Reversion.
191.	Examination of Engine Room Ratings—September, 1943.
192.	Gun Mountings—Test of Recoil Cylinder Liquid.
193.	Ammunition—Pyrotechnics and Rockets, Signal—Star Shell—All Calibres—Minimum Ranges at which Satisfactory Functioning Can be Expected.
194.	W/T Testing Equipment for Frigates.
195.	A.M.S. Vessels—Modification to Steam Driven Boiler Room Fans.
196.	Depth Charges Type (M) and Depth Charges Mk. VIII—Defective Bungs, Charge Case.
197.	Orchestral Band Instruments—Percentage Charge and Grants-in-Aid.
198.	Books and Forms.

C.3659/44.

188.

H.M.A.S. "HARMAN"—COMMISSIONING.

It has been decided that, as from 1st July, 1943, when ledgers were transferred from H.M.A.S. *Kuttabul*, the naval W/T Stations at Canberra be commissioned as an independent command to be known as H.M.A.S. *Harman*.

2. A 45-ft. 80-h.p. Diesel motor boat, attached to H.M.A.S. *Penguin*, is to be regarded as the "Name Ship," *vide* Navy Order 177 of 1943.

—(474/208/504.)—

189.

QUARTER BILLS—AMENDMENTS.

In order to facilitate the necessary amendments to Quarter Bills and allow for accommodation in ships to be taken in hand consequent on alteration to armament, the following action is to be taken:—

(a) The fitting-out officer is to discuss with the Commanding Officer the alterations required to be made to the Quarter Bill and to accommodation consequent on the alteration or addition to armament.

(b) The proposed alterations should be signalled to the Naval Board and repeated to the Naval Officer-in-Charge, Flinders Naval Depot.

2. On receipt of this signal, the additional substantive and non-substantive ratings, if any, required to complete complement, should be drafted by the Naval Officer-in-Charge, Flinders Naval Depot, pending Naval Board decision on proposed additions to complement.

(463/202/1314.)

190.

R.N. RATINGS ON LOAN TO THE R.A.N.—DISPOSAL OF SERVICE CERTIFICATES ON REVERSION.

Instances have occurred recently where Service Certificates of R.N. ratings reverting from the R.A.N. have not been forwarded to the United Kingdom until long after the rating has left Australia or until specifically requested by his home port or the Naval Liaison Officer, London.

2. The attention of all concerned is drawn to the importance of dispatching the Service Certificate at the same time as the rating embarks, *vide* K.R. and A.I., Article 856, clause 2. In cases where this is not possible, the Naval Liaison Officer should be informed by letter.

(453/202/951.)

191.

EXAMINATION OF ENGINE ROOM RATING—SEPTEMBER, 1943.

With reference to Navy Order 13 of 1944, the following additional results are promulgated:—

O.N.	Name.	Present Rating.	Application Received From.	Result.
<i>E.R.A. A/4th Class for Confirmation.</i>				
F/4364 ..	Ditchburn, A. J. ..	E.R.A. Acting 4th Class	Gladstone ..	Passed Supr.
S/7523 ..	Galbraith, J. D. ..	" "	Benalla ..	" "
S/6018 ..	Hogan, J. M. ..	" "	Manoora ..	" "
S/6093 ..	McEvoy, C. W. ..	" "	Broome ..	" "
S/5965 ..	Mitchell, A. P. ..	" "	Birchgrove Park ..	" "
H/2249 ..	Rigby, R. F. G. ..	" "	Wagga ..	" "
S/7740 ..	Russell, S. A. ..	" "	Goonambee ..	" "
S/7018 ..	Wood, E. C. F. ..	" "	Shepparton ..	" "
PM/4123	Winter, J. R. ..	" "	Castlemaine ..	Passed Sat.

2. The necessary notation should be made on Form A.S. 1233g.

3. Forms A.S. 442 for successful and unsuccessful candidates will be forwarded to ships and establishments concerned for signatures by the candidates. The original is to be retained by the candidate and the duplicate forwarded to the Commodore Superintendent of Training.

(465/207/1222.)

192.

GUN MOUNTINGS—TEST OF RECOIL CYLINDER LIQUID.

A further case has occurred where the recoil cylinder liquid has been found acidic with consequent damage to cylinder, piston, and glands.

The attention of all concerned is drawn to B.R. 292, Instructions for the Maintenance of Naval Ordnance and Gun Mountings, paragraphs 382 to 385, Admiralty Fleet Order 1963/40, and Navy Order 315 of 1942.

(490/210/360.)

193.

AMMUNITION—PYROTECHNICS AND ROCKETS, SIGNAL—STAR SHELL—ALL CALIBRES—MINIMUM RANGES AT WHICH SATISFACTORY FUNCTIONING CAN BE EXPECTED.

Appended is an advance copy of Admiralty Fleet Order 972/44, which has not yet been promulgated on the Australia Station:—

"Several cases have recently been reported in which the parachutes of star shell have failed, resulting in too rapid descent of the star. On some of these occasions inquiry has shown that the shell had been set to burst at so short a range that satisfactory functioning could not be looked for.

2. Two natures of parachutes are to be found in shell. The original type and a much stronger type recently introduced and now in production. Shell containing this latter are marked with a green star on a white background in place of the normal red star on a white background.

3. The following table shows for each calibre and for each of the types of parachute the minimum range for correct functioning. If fuzes are set to burst below these ranges, parachute failures will be common.

Equipment.	Old type parachute.	New type (Green star).
	Yards.	Yards.
Q.F., 5.25-in., Mark I	6,200	2,600
Q.F., 4.7-in., Mark XI	4,200	1,100
Q.F., 4.7-in., Marks IX and XII ..	1,800	1,000
Q.F., 4.5-in., Marks I, III and IV	3,200	1,000
Q.F., 4-in., Mark XIX	1,000	1,000
Q.F., 4-in., Mark XVI	1,700	1,000
Q.F., 4-in., Mark V	1,000	1,000."

(408/204/2291.)

194.

W/T TESTING EQUIPMENT FOR FRIGATES.

Approval has been given to the addition of the under-mentioned item to the list of Special Allowances of Naval Stores for R.A.N. Frigates, for testing W/T and S.R.E. equipment:—

Patt. No.	Description.	Qty.	Remarks.
—	"Calstan" Valve Circuit Tester	I No.	—

2. Supply of the above-mentioned item to H.M.A. Ships concerned will be effected without demand by the Superintending Naval Store Officer, Sydney, as early as practicable.

(603/293/676.)

195.

A.M.S. VESSELS—MODIFICATION TO STEAM DRIVEN BOILER ROOM FANS.

In view of the failure of impellers in several boiler room fans in A.M.S. Vessels, all such vessels are to include an item in their next supplementary Defect List to cover a modification to impellers, which is to be carried out by Base Staffs, in accordance with the under-mentioned instructions.

2. Engineer Officers are to examine the fan for winding of the blades and bending of the stay rods, as shown in the diagram attached. (Stay rod stems are straight when fitted.)

3. If the fan has wound more than 1 inch, then the modification is to be carried out at the earliest opportunity.

3. Procedure to be adopted in Rebuilding is as follows:—

(a) Stay Rods and Lugs.

(i) The existing stay rods, if of $\frac{1}{2}$ -in. diameter, are to be removed and replaced by stay rods as shown in the diagram.

(ii) The tapped holes in the impeller boss are to be opened out to take screwed lugs of new design as shown on the diagram. (The lugs are to be a tight fit in these holes.)

(iii) The boss is to be spot faced to ensure that the hole in the lugs will be in alignment with the stay rods when the lugs are screwed home on to the shoulder.

(iv) Stems of new stay rods when fitted are to be straight.

(v) The stay rods are to be welded to the impeller front plate (suction eye shrouding) before riveting and as shown on the sketch.

(b) Blading.

(i) The blading is to be examined for cracking at the junctions with the front and back plates.

(ii) If cracks are found and sufficient spare blades are available and time permits, it is preferable to reblade the whole impeller with "Armco" blades.

(iii) If spare blades are not available, temporary repairs may be effected by welding cracked blades and re-riveting with 5/16-in. hot driven rivets.

(iv) When it is desired to renew some defective blades in the impeller, it is to be borne in mind that the new blades may be heavier than the existing blades. If this is so, blades diametrically opposite the defective blades should be renewed also to assist in balancing.

(v) 5/16-in. diameter hot driven snap headed rivets are to be used in all repairs to fan blading. The rivet when hot is to be as close a fit in the hole as is practicable, and is to completely fill the hole when riveted up.

(vi) If an impeller pack plate is distorted, it is to be straightened before completing the fan assembly.

(vii) The blade end and the fan portion to which they are riveted are each to be coated with "Anodite" or red lead before riveting in order to prevent corrosion between.

(viii) The whole of the fan is to be given a coat of red lead paint when the repairs are completed.

(c) Balancing of Fans.

(i) A duplicate shaft is to be made on which the fan impeller is a good fit. The impeller and shaft are to be rolled along horizontal knife edges; the stay rods are then to be used to make the front plate run true. The stay rod nuts should then be slackened back to check if one rod is pulling against another. The completed impeller should run true with the least possible tension in the stay rods. The stay rod nuts are then to be locked with either lock nuts or spot welding, preferably with lock nuts.

(ii) When the fan is fitted on the engine shaft, the boss is not to move out of centre when the key is driven home. Feeler gauges are to be used alongside the key to test for this.

4. The manufacturers of the fans have arranged for stocks of new blades, and of forgings for eyebolts and stay rods, to be held by their agents in Brisbane, Sydney, and Melbourne.

5. The Commanding Officers of all A.M.S. Vessels are to forward a report through their Administrative Authority when this modification has been carried out.

(603/290/567.)

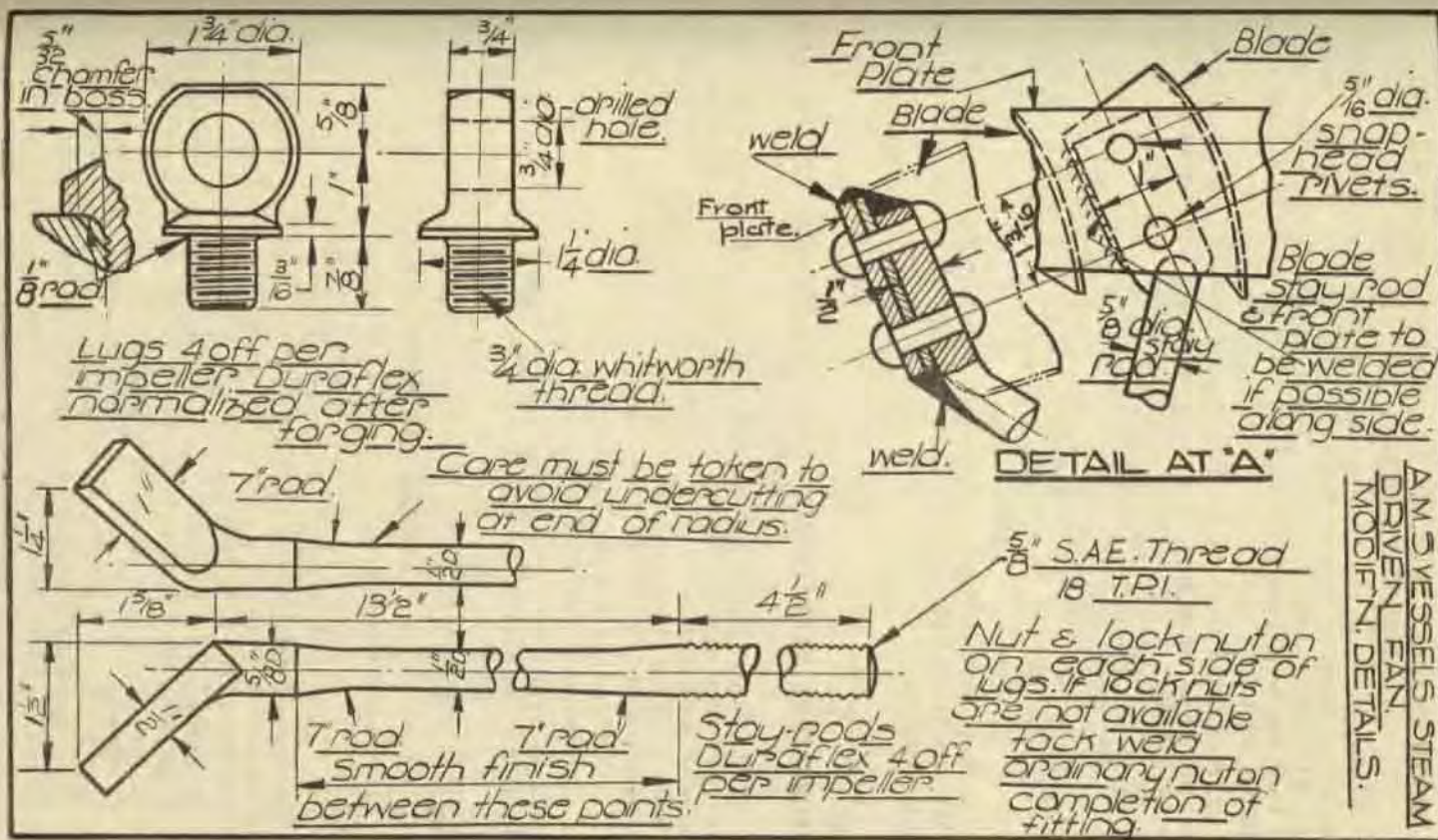
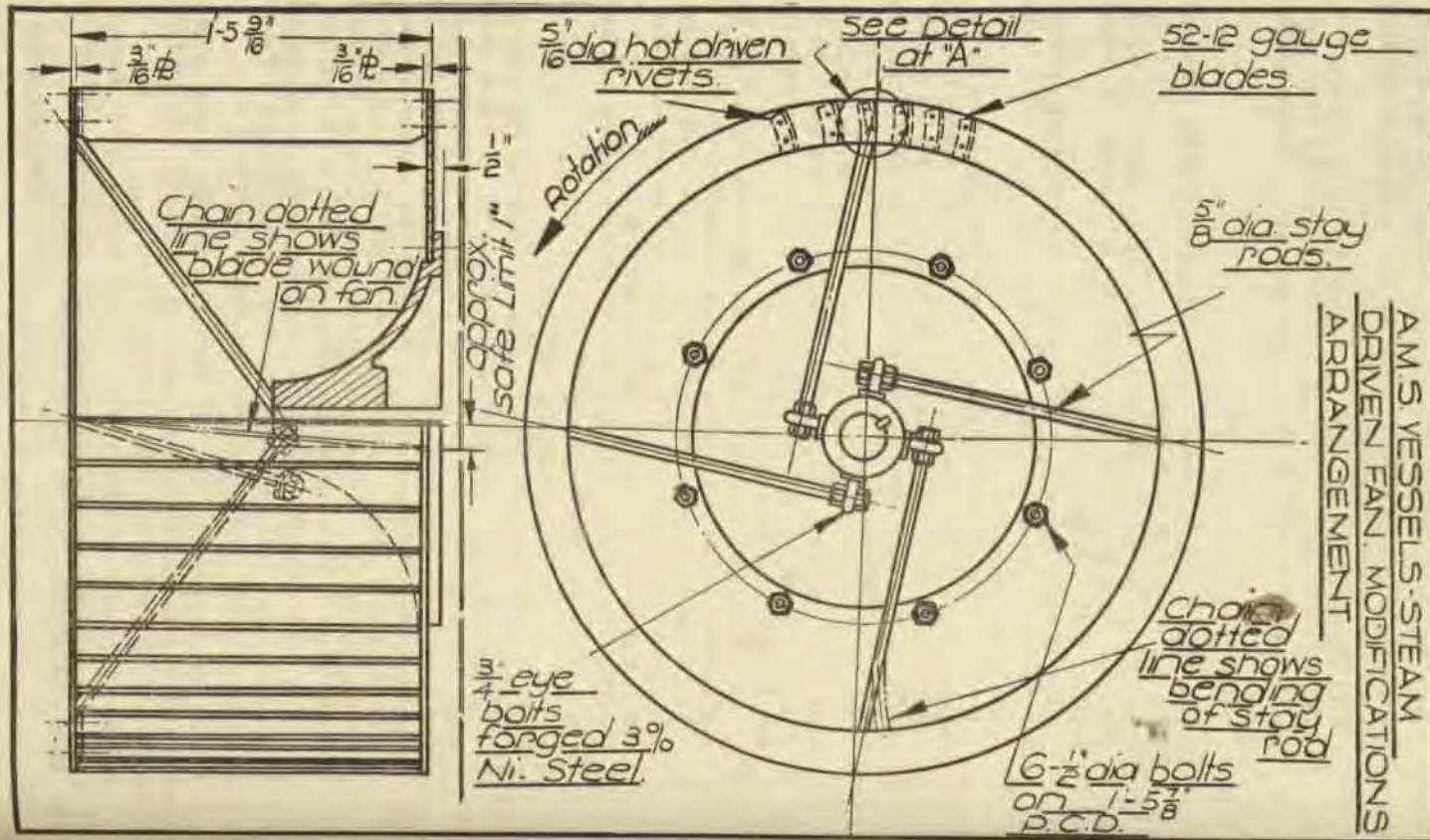

AM'S VESSELS STEAM
DRIVEN FAN
MODIFN. DETAILS.

196.

**DEPTH CHARGES TYPE (M) AND DEPTH CHARGES MK. VIII—
DEFECTIVE BUNGS, CHARGE CASE.**

Consequent upon reports being received that, due to faulty design, the filling bungs of Depth Charges Type (M) and Depth Charges Mk. VIII are working loose, and in some cases being lost, a new design of bung has been introduced under the description Bung, Charge case, St. No. 8384.

2. Supplies of this item are now coming forward from manufacture and will be issued without demand, as follows, for replacement of lost, or loose, bungs:—

60	..	Fremantle.
20	..	Darwin.
150	..	Swan Island.
150	..	S.A.S.O., Sydney.
20	..	Milne Bay.

3. Ships and establishments are to examine all Depth Charges Type (M) and Mark VIII as convenient, and any lost or loose bungs are to be replaced.

(471/205/2111.)

197.

**ORCHESTRAL BAND INSTRUMENTS—PERCENTAGE CHARGE AND
GRANTS-IN-AID.**

With effect as from 1st July, 1944, and for the duration of the war, the percentage charges payable by officers of H.M.A. Ships on the value of orchestral instruments on board in accordance with the provisions of Naval Financial Regulations and Instructions, Article 224, is abolished and the grants-in-aid reduced to the following amounts:—

Flagship—£16 per annum.
Cruisers—£12 per annum.

2. An appropriate notation is to be made in the Naval Financial Regulations and Instructions and also in C.O.R., Article 485, clause 3. (670/203/416.)

198.

BOOKS AND FORMS.

The under-mentioned form has been introduced for use in the R.A.N.:—

A.S. 1246x "Teleprinter History Sheets."

2. Naval Establishments where T/P ratings (including W.R.A.N.S.) are allowed on complement are to place demands on the Superintending Naval Store Officer, Sydney.

3. Entries from temporary History Sheets are to be transferred to Form A.S. 1246x on receipt of supply, which should include 50 per cent. spare.

(480/202/4569.)

By Authority: H. E. DAW, Government Printer, Melbourne.

RESTRICTED.(FOR OFFICIAL USE ONLY.)

Commonwealth Navy Orders.

Navy Office, Melbourne,

25th April, 1944.

The following Orders, having been approved, are hereby promulgated for information and guidance and necessary action.

By direction of the Naval Board,

J. P. Macandless
Secretary.

*The Rear-Admiral Commanding H.M.A. Squadron,
and Commanding Officers of H.M.A. Ships,
Officers in Charge of H.M.A. Naval
Establishments, and others concerned.*

TABLE OF CONTENTS.

No.	Subject.
199.	Port Directors.
200.	Honours and Awards to R.A.N. Personnel.
201.	1939-43 Star—persons Eligible, and Definition of "Service Afloat."
202.	Examination for the Rank of Paymaster Lieutenant-Commander, R.A.N.
203.	Educational Test I, December, 1943.
204.	Visual Signallers, Coders, T/P and Automatic Morse Operators, W.R.A.N.S.—Advancement.
205.	Applications from Naval Personnel for Discharge.
206.	Naval Personnel Repatriated—Liability for Further Active Service.
207.	Signal Traffic.
208.	4" Mark XXIII and XXIII* Gun Mountings.
209.	Anti-Gas Eyeshields and Ointment—Revision of Allowances.
210.	A.M.S. Vessels—Refrigerating Plant for Cold Room.
211.	Lieutenant (Emergency or Retired List)—Outfit Gratuity Payable on Promotion from Commissioned Warrant Officer or Warrant Officer.
212.	Life-Saving Equipment—Sleeves and Torches for Inflatable Lifebelts.
213.	Mosquito Nets.
214.	Supply of Civilian Clothing to Members of the Naval Forces on Discharge.
215.	Conservation of Sheets and Pillow Slips.
216.	Shipment of Mining Stores—Case Markings.
217.	Accounts for Provisions—Necessity for Prompt Payment.
218.	Corrigendum.

C.4081/44.

199.

PORT DIRECTORS.

With reference to Navy Orders 526 of 1943 and 148 of 1944, the Port Directorates at Buna and Arawe have now been closed.

(1937/2/232.)

200.

HONOURS AND AWARDS TO R.A.N. PERSONNEL.

With reference to Navy Order 494 of 1943, the following additional Honours and Awards have been made to personnel of the Royal Australian Navy:—

1. For bravery and skill in actions in the Mediterranean, while serving in light coastal craft:—

BAR TO DISTINGUISHED SERVICE CROSS.

Lieutenant Harry Frederick Wadds, D.S.C., R.A.N.V.R.

2. For gallantry and devotion to duty in a determined and successful attack on "E" boats while serving on convoy duty in one of H.M. Ships:—

THE DISTINGUISHED SERVICE CROSS.

Lieutenant Colin Phillip Dickeson, R.A.N.V.R.

3. For bravery and skill in a successful patrol in one of His Majesty's Submarines:—

THE DISTINGUISHED SERVICE CROSS.

Lieutenant William Evan Ironside Littlejohn, R.A.N.V.R.

4. For outstanding courage and devotion to duty:—

THE DISTINGUISHED SERVICE CROSS.

Lieutenant Kenneth Robert Hudspeth, R.A.N.V.R.

5. For gallant and distinguished service in face of heavy opposition from the enemy:—

THE DISTINGUISHED SERVICE CROSS.

Lieutenant Kenneth Melville Brennan, R.A.N.V.R.

6. For bravery and steadfast devotion to duty:—

M.B.E.

Lieutenant Geoffrey John Cliff, G.M. and Bar, R.A.N.V.R.

Lieutenant Charles George Croft, R.A.N.R.

7. For great bravery and enterprise while serving in a defensively equipped merchant ship in helping to dispose of an unexploded bomb after an enemy air attack:—

B.E.M.

Able Seaman Ronald Larkin, F/2363.

8. For leadership and enterprise:—

O.B.E.

Commander (E) Roger Grosvenor Parker, R.A.N., H.M.A.S. *Hobart*.

M.B.E.

Surgeon Lieutenant Ronald Mackenzie MacIntosh, R.A.N.R., H.M.A.S. *Hobart*.

Lieutenant Peter Gyllies, R.A.N., H.M.A.S. *Hobart*.

B.E.M.

Sick Berth Petty Officer Edward Hamilton Cornish, 20420, H.M.A.S. *Hobart*.

Engine Room Artificer 3rd Class, Patrick Edward Randolph Goonan, 23857.

Shipwright 3rd Class, Connolly Peter William Bryant, 24655, H.M.A.S. *Hobart*.

MENTION IN DESPACHES.

Surgeon Lieutenant (D) Frank Lionel Roden-Smith, R.A.N., H.M.A.S. *Hobart*.

Mr. Christopher Clement Connolly, Warrant Engineer, R.A.N., H.M.A.S. *Hobart*.

Chief Stoker Matthew Goodman, 6806, H.M.A.S. *Hobart*.

Mechanician Thomas Vincent Jones, 17736, H.M.A.S. *Hobart*.

9. For distinguished services during the passage to Malta of an important convoy:—

THE DISTINGUISHED SERVICE MEDAL.

T/Acting Petty Officer William Rutledge Anderson, PM/1678, D.E.M.S. *Dorset*.

MENTION IN DESPACHES.

10. For skill and devotion to duty while in charge of craft carrying important supplies in dangerous and unchartered waters:—

Mr. John Roy Bennetts, Ty. Warrant Officer, R.A.N.R. (S).

11. For gallant and distinguished service and untiring devotion to duty in operations which led to the capture of Sicily by Allied Forces:—

Lieutenant Douglas John Browne, R.A.N.V.R.

12. For gallant and distinguished services in action with enemy submarines:—

Lieutenant Commander Maurice George Rose, R.A.N.V.R.

13. For gallant leadership and devotion to duty under heavy and continued fire from the enemy:—

Lieutenant Douglas John Browne, R.A.N.V.R.

14. For good service in successful attacks on an enemy submarine:—

Able Seaman Alfred Saunders, 21091.

15. New Year's Honours, 1944:—

COMPANION OF THE BATH.

Vice-Admiral Thomas Bernard Drew, O.B.E., R.N. (Rtd).

C.B.E.

Captain (Commodore 2nd Class) George Dunbar Moore, R.A.N.

O.B.E.

Lieutenant-Commander Eric Augustus Feldt, R.A.N.

M.B.E.

Lieutenant-Commander Ronald Alexander Denovan, R.A.N.V.R.

Lieutenant John Charles Elley, R.A.N.

FOREIGN AWARDS AND DECORATIONS.

16. In recognition of important services as Deputy Naval Officer-in-Charge, Broome, rendered by him to the crew of the Netherlands Navy Planes, during an enemy attack on 3rd March, 1942:—

CROSS OF MERIT.

(Conferred by the Queen of the Netherlands.)

Lieutenant David Llewellyn Davis, R.A.N.V.R.

17. For exceptionally meritorious conduct in the performance of outstanding services to the Government of the United States during a Reconnaissance Mission to enemy-held Russell Islands on the night of the 12th February, 1943. Acting as a volunteer pilot, Lieutenant Howe navigated a captured Japanese sampan through miles of inadequately chartered reefs at night and landed his party safely. Through his intimate knowledge of the islands and the treacherous waters en route, he helped make available a report on physical aspects of the islands, thereby contributing to the subsequent occupation of a strategic position:—

LEGION OF MERIT.

Degree of Legionnaire.

(Conferred by the President of the United States of America.)

Ty. Lieutenant Gordon Howe, R.A.N.R. (S).

(448/201/1507.)

(*This Order will be Reprinted for Posting on Notice Boards.*)

201.

1939-43 STAR—PERSONS ELIGIBLE AND DEFINITION OF "SERVICE AFLOAT."

Pending the issue of final instructions, the following is issued in amplification of Navy Order 466 of 1943.

2. The following classes are eligible for the 1939-43 Star:—

- All officers and men of the Royal Australian Navy and its Reserves.
- Officers and men of the Merchant Navy under T.124 and like agreements in His Majesty's Ships of war.
- Canteen staff serving in a ship of war at sea.
- Civilians with protective commissions serving in His Majesty's Australian Ships.

3. Definition of "Service Afloat":—"Service Afloat" means service while borne on the books of—

- A sea-going ship of war which goes to sea.
- A parent ship for service in commissioned sea-going tenders.
- A commissioned ship for such other sea-going services as the Naval Board may declare to qualify for this purpose. In this category will be included—
 - Service while embarked for duty in merchant ships (e.g., D.E.M.S. personnel, Commodores of Convoy and their staffs, &c.).
 - Service in sea-going Boom Defence and Examination vessels.
 - Passage in a merchant ship through the areas specified in Navy Order 466 of 1943.

4. In any case of difficulty the Naval Board shall determine, for the purpose of the award, which vessels or classes of vessels shall be regarded as ships of war, and what nature of service afloat shall be considered as sea service or harbor service.

5. Supplies of the ribbon are now available, and a record should be kept of those to whom ribbons are issued on Form A.S. 1129Z. First supply will be issued without demand by the Superintending Naval Store Officer, Garden Island, Sydney.

(448/201/1578.)

(*This Order will be Reprinted for Posting on Notice Boards.*)

202.

EXAMINATION FOR THE RANK OF PAYMASTER
LIEUTENANT-COMMANDER, R.A.N.

An examination for the rank of Paymaster Lieutenant-Commander will be held towards the end of 1944.

2. Officers who are eligible and desire to sit for this examination should forward their applications to reach Navy Office by the 1st September, 1944.

(465/206/264.)

203.

EDUCATIONAL TEST I, DECEMBER, 1943.

The following ratings passed Educational Test I, held on 14th December, 1943:—

Name.	Rating.	Official Number.
<i>H.M.A.S. Adelaide</i> Lingard, Victor M.	Ordinary Seaman	S/8797
<i>H.M.A.S. Australia</i> Collins, Maxwell E.	Able Seaman	P.M/3805
<i>H.M.A.S. Cerberus</i> Bolton, Eric R.	Stoker, 2nd Class	S/8975
Burger, Dudley J.	" "	B/4645
Curtin, Arthur J.	Stoker	W/1954
Dempsey, Roderick	" "	W/2044
Emerson, Bruce N.	Stoker, 2nd Class	S/8957
Gaffney, Lawrence B.	" "	P.A/4361
Harris, Wallace N.	" "	S/8924
Hipkin, Kenneth E.	" "	S/9025
Mellersh, Frank A.	Stoker	S/5475
McAdam, Allan S.	" "	P.A/3030
Neighbour, Geoffrey L.	Stoker, 2nd Class	P.A/4422
O'Donahue, John M.	" "	H/2646
O'Shea, Kevin J.	" "	B/3480
Payne, William T.	" "	S/8931
Pinkerton, Maxwell D.	" "	S/9068
Sargeson, Maxwell	" "	H/2645
See, Donald F.	" "	B/4847
Swanson, Cleveland	Stoker	W/1483
Uhe, Keith	Stoker, 2nd Class	W/2940
Vaughan, Neville F.	" "	S/8935
Wood, Peter M. L.	" "	S/8990
Zeeno, Alfred N.	" "	W/2946

EDUCATIONAL TEST 1.—*continued.*

Name.	Rating.	Official Number.
<i>H.M.A.S. Manoora</i> McKechnie, William	Shipwright, 3rd Class	F/2835
<i>H.M.A.S. Melville</i> Lucas, Reginald G.	Stoker	26718
<i>H.M.A.S. Moreton</i> Connell, David P. Girdler, Laurence E. Morrison, Donald S. Ward, George N.	Ordinary Coder Stoker, 2nd Class Shipwright, 2nd Class Ordinary Seaman	26507 B/4388 21311 P.M/5912
<i>H.M.A.S. Penguin</i> Rose, Leeson E.	Ordinary Seaman	S/7900
<i>H.M.A.S. Stuart</i> Larkey, Leo J. Miller, George T. Thomson, Ronald Triffitt, Sydney Whittle, Stanley	Ordinary Seaman Able Seaman Stoker Acting Leading Stoker " " "	S/8129 S/7467 B/3270 S/4179 W/1632
<i>H.M.A.S. Torrens (H.M.A.S. Mary Cam)</i> Harwood, Ralph F.	Ordinary Seaman	P.A/4135
<i>H.M.A. Boom Defence Depot, Darwin</i> Chandler, Ernest N. Cutcliff, John W. Parkes, Thomas G. Ward, Frederick E.	Cook Stoker Ordinary Seaman Stoker	S/6399 H/1808 S/7853 P.A/2667
The following qualified educationally for Acting Leading Stoker :—		
<i>H.M.A.S. Cerberus</i> Gray, Gordon S. Maxwell, Raymond A. Monks, Stanley N. McGregor, Kenneth W. McGuinness, Leslie A. Nickels, Leslie T. Quigley, Cecil J. Scarman, Clem A. Wackett, Stirling J. White, Lawrence E.	Stoker Stoker, 2nd Class " " Stoker Stoker, 2nd Class " " " "	W/2507 P.A/4363 W/2944 S/8873 S/8902 W/1484 S/8932 P.A/4248 P.A/4252 P.A/407
<i>H.M.A.S. Moreton</i> Phillips, Francis R. Seymour, Charles C.	Stoker "	S/5130 W/1701
<i>H.M.A.S. Stuart</i> Riley, George F.	Stoker	S/5249
<i>H.M.A. Boom Defence Depot, Darwin</i> Alldis, Albert E.	Stoker	W/1832

(465/205/662.)

(This Order will be Reprinted for Posting on Notice Boards.)

204.

VISUAL SIGNALLERS, CODERS, T/P AND AUTOMATIC MORSE OPERATORS, W.R.A.N.S.—ADVANCEMENT.

The following conditions for advancement are established for the above W.R.A.N.S. personnel:—

- (a) The minimum time qualifications for advancement to Leading and Petty Officer rates are to be the same as for other branches of the W.R.A.N.S.
- (b) Attainment of V/S Non-substantive standard, although forming a condition of advancement, will not entitle a rating to any additional credit of pay or allowances.
- (c) In the event of failure to pass professionally for higher rate, a rating is not to take the examination again for at least three months.
- (d) All examination papers will be set by H.M.A. Signal School, and examinations will normally be held on the first day of each odd month. Numbers of candidates wishing to take examinations are to reach the Naval Officer-in-Charge, Flinders Naval Depot, by the fifteenth of each even month. Worked papers are to be corrected by the Examining Officer.
- (e) Forms AS/1124 are to be rendered as for Naval Communications ratings to the Commodore Superintendent of Training.
- (f) Forms S/507 are to be rendered to the Commodore Superintendent of Training.

A roster of ratings recommended in order of date of passing (which will be the actual date of examination) will be maintained by the Commodore Superintendent of Training, who will authorize advancements to leading rates and above according to vacancies in numbers allowed.

- (g) No W.R.A.N.S. rating should be recommended for advancement unless she is a volunteer to serve in any shore establishment in the Commonwealth.

2. V/S Ratings, W.R.A.N.S.

- (a) The Non-substantive rates of Trained Operator V/S, V/S3, and V/S2 shall be applicable to V/S ratings W.R.A.N.S. in the same manner as to Naval V/S ratings, except that there will be only one standard and courses for higher rating will not normally be carried out.

(b) The same percentages in the following subjects are required for V/S. ratings W.R.A.N.S. as are laid down in Navy Order 62 of 1942 for Naval ratings:—

* Procedure.

* Miscellaneous (to include Fleetwork).

Oral.

* Coding (including Coding Instructions).

Semaphore.

Morse Flag.

Flashing.

* Practical Procedure.

* Questions will be based on the knowledge required of Leading Signalmen and Yeomen in Shore Signal Stations.

(c) Practical examinations are to be conducted by a Qualified Signal Officer, Base Signal Officer or Signal Boatswain, and candidates must be recommended by these officers and the Executive Officer (W.R.A.N.S.) as being fit in all respects to hold the higher rate.

3. Coders, W.R.A.N.S.

(a) Pass professional examinations of similar standard to those referred to in Navy Order 339 of 1943, as amended by Navy Order 60 of 1944 and in Navy Order 339 of 1943, paragraph 2 (iii) (b).

(b) To be recommended after an interview by a Qualified Signal Officer, Base Signal Officer, or Communications Branch Warrant Officer as being capable in all respects of carrying out the duties of a Leading Coder or Petty Officer Coder respectively in any shore establishment.

(c) Recommendation in (b) above must be confirmed by the Executive Officer, (W.R.A.N.S.).

4. Teleprinter Operators, W.R.A.N.S.

(a) Pass a transmitting test in P/L and Cypher at the rates laid down in Navy Order 258 of 1942 for advancement to Leading Signalman T/P and Yeoman T/P.

(b) Pass an oral examination in which the candidate must show a complete knowledge of Naval and Inter-Service T/P procedure in order to qualify for Leading Teleprinter Operator, and a thorough knowledge of Naval and Inter-Service T/P procedure and Signal Distributing Office work to qualify for Petty Officer Teleprinter Operator. Examinations to be conducted by a qualified Signal Officer, Base Signal Officer, or Communications Branch Warrant Officer.

(c) To be recommended by the Examining Officer and the Executive Officer (W.R.A.N.S.) as being suitable for Leading or Petty Officer rate.

5. Automatic Morse Operators, W.R.A.N.S.

(a) Pass professional examination of similar standard to that referred to in A.F.O. 4794/43, paragraph 3.

(b) To be recommended by the Examining Officer and the Executive Officer (W.R.A.N.S.) as being suitable for Leading Signalmen (A/M).

6. Communications Branch ratings W.R.A.N.S. who have been rated up already without passing professional examinations for advancement, will be required to do so in order to be confirmed in their new rating.

7. W/T Ratings.

Regulations for the advancement of W/T ratings, W.R.A.N.S., are contained in Navy Order 470 of 1943.

(432/224/1037.)

205.

APPLICATIONS FROM NAVAL PERSONNEL FOR DISCHARGE.

When applications for discharge are referred to Man-Power Authorities in accordance with Navy Order 527 of 1943, the Man-Power Authority should be requested to state whether, if discharge is recommended, a recruit outside the normal quota will be allowed in replacement.

(451/201/118.)

206.

NAVAL PERSONNEL REPATRIATED—LIABILITY FOR FURTHER ACTIVE SERVICE.

The provisions of A.F.O. 5188/43 are applicable to the Royal Australian Navy. For this purpose, however, the words "United Kingdom" in paragraph 3 should read "Australia."

(429/201/781.)

207.

SIGNAL TRAFFIC.

A gradual rise in the volume of signal traffic has occurred during recent months.

2. The attention of all concerned is therefore to be drawn to the absolute necessity for ensuring that only essential messages are authorized for despatch, and that the fullest use is made of Air Mail letters.

3. In this connexion, attention is directed to Navy Office confidential memorandum No. 056346, dated 27th August, 1943, containing General Instructions to Originating Officers concerning signals.

(622/205/1347.)

208.

4" MARK XXIII AND XXIII* GUN MOUNTINGS.

The following modifications have been approved for the above mountings. H.M.A. Ships are to take the necessary steps to incorporate these modifications if not already done, and to obtain any additional equipment necessary:—

Modification.	Action to be Taken.
1. <i>Spring Case Front Cap.</i> —Hole for access to Drain Plug to be opened out to 1.875 inches diameter.	To be carried out by Gunmounting Depots and Base Ordnance Staffs.
2. (a) <i>Plug "B"</i> to be replaced if existing plug is cheese-headed. (b) <i>Buffer Cylinder.</i> —Hole, Drain Plug to be opened out to .75 inch B.S.F. to take new Plug. (c) <i>Drain Plug</i> to be replaced by .75 inch B.S.F. square-headed plug. (d) <i>Spanner No. 7</i> to be supplied for use with (a) and (c) above.	Items required are to be manufactured by, and modifications (a), (b), (c), and (d) to be carried out by Gunmounting Depots and Base Ordnance Staffs.
3. <i>Cap Spring Case Rear.</i> —Modified by fitting Phosphor Bronze Bush and Lubricator.	Ships to demand modified Caps through the nearest Gunmounting Depot or Base. Bases to demand from Gunmounting Depot, Garden Island, Sydney. Gunmounting Depots or Base Ordnance Staffs to fit.
4. <i>Elevating and Training Gear.</i> —Washers, felt, .266 inch in thickness to be fitted in Covers.	Gunmounting Depots and Base Ordnance Staffs to fit. Washers to be demanded from nearest Gunmounting Depot or Base. Bases to demand requirements from Gunmounting Depot, Garden Island, Sydney.
5. <i>Lower Elevating Gear Box.</i> —Outer Cover Lubricator to be fitted.	To be modified by Gunmounting Depots and Base Ordnance Staffs.
6. <i>Sights.</i> —Distance piece of Sight Bracket, Weather Cover to be fitted where distance piece is cut away to clear gun and Recoil Gear.	To be modified by Gunmounting Depots and Base Ordnance Staffs.
7. <i>Shield.</i> —Hole to be cut in shield on left-hand side and fitted with cover plate, to facilitate removal of sight bar, without removal of shield.	Gunmounting Depots to modify.
8. <i>Training Clips fitted with Roller Units.</i> —Inspection hole with preserving screw to be fitted, to facilitate inspection when testing these rollers for bearing on roller path.	Gunmounting Depots and Base Ordnance Staffs to modify.
9. <i>Water Seals between Training Clips.</i> —Round-headed screws securing angle strips to the underside of upper racer plate to be replaced by hexagon-headed screws.	Gunmounting Depots and Base Ordnance Staffs to fit.

4" MARK XXIII AND XXIII* GUN MOUNTINGS.—*continued.*

Modification.	Action to be Taken.
10. <i>Tools.</i> —Spanners Nos. 9, 10, and 11 to be supplied for Nut Securing Recoil Rod, Breech end to Buffer Cylinder Nut securing Piston, and Nut for Gun Lug respectively.	To be demanded through nearest Gunmounting Depot or Base. Bases to demand from Gunmounting Depot, Garden Island Sydney.
11. <i>Retaining Nut Spring Case rear end.</i> —Size of hexagon reduced from 4.18 inches to 4 inches across flats to fit spanner supplied for Spring Case Front Cover.	Gunmounting Depots and Base Ordnance Staffs to modify.

(490/203/1183.)

209.

ANTI-GAS EYESHIELDS AND OINTMENT—REVISION OF ALLOWANCES.

The allowances of anti-gas eyeshields and ointment have been revised, and the following will apply in future:—

(a) All Naval personnel ashore and afloat, R.A.F.A. crews, and canteen staffs afloat—

2 No. eyeshields, in carton, and 1 No. 2-oz. container of ointment, per man, as a personal issue.

A reserve of 50 per cent. is to be carried in H.M.A. Sea-going Ships—A.M.S. and above.

(b) Additional for H.M.A. Ships for the equipment of landing parties—

4 No. eyeshields (in cartons, containing 2 eyeshields), and 1 No. 2-oz. container of ointment, for each member of the landing organization. This additional allowance will allow of each person in the landing organization being equipped with 6 No. eyeshields, and 2 No. 2-oz. containers of ointment.

2. As supply of the eyeshields and ointment is treated as a personal issue, ships and establishments are to take action to ensure that all personnel have been supplied, and that any eyeshields and ointment which may at present be held by personnel in excess of the revised allowances are withdrawn. Particulars of any eyeshields and ointment held surplus to requirements in establishments after the above allowances have been met are to be forwarded to Navy Office, when instructions will be issued as to disposal.

3. Demands for requirements of cartons (each for holding 2 No. eyeshields) should be forwarded to the Superintending Naval Store Officer, Sydney.

(669/201/1031.)

210.

A.M.S. VESSELS—REFRIGERATING PLANT FOR COLD ROOM.

Reports have been received from certain A.M.S. Vessels regarding unsatisfactory operation of the refrigerating plant, due to inefficient air cooling of the condenser.

2. In ships not already so fitted, arrangements should be made for the air supply trunking, at present led in at the top of the machinery compartment, to be extended downwards and outboard, and so arranged that the air is deflected into the intake side of the air-cooled condenser.

3. An item should be included in the next Supplementary Defect List to cover this work.

(603/289/448.)

211.

LIEUTENANT (EMERGENCY OR RETIRED LIST)—OUTFIT GRATUITY PAYABLE ON PROMOTION FROM COMMISSIONED WARRANT OFFICER OR WARRANT OFFICER.

With reference to Naval Financial Regulations and Instructions, Article 41 (as amended by Navy Order 334 of 1942) and Article 118, a Lieutenant (or equivalent rank) of the Emergency or Retired List promoted from Commissioned Warrant Officer or Warrant Officer on or immediately prior to retirement or during retention or recall for Active Service, may be granted a refund of necessary vouched expenditure incurred in converting uniform to the rank of Lieutenant (Emergency or Retired List), subject to the following conditions:—

- (a) For a Sea-going Lieutenant the amount payable shall not exceed £45, inclusive of any uniform grant received in respect of recall for service, and/or on promotion to Lieutenant immediately prior to retirement as such;
- (b) For an Auxiliary Service Lieutenant the amount payable shall not exceed £15; and
- (c) Refund of expenditure will be strictly limited to disbursements on account of the following articles of uniform:—

Undress coat
Trousers (two pairs)
White tunics
White trousers
Helmet
White cap or white cap covers
Shoulder straps
Cap and badge
Greatcoat or raincoat.

2. Before payment is made, receipted invoices in each case are to be forwarded for prior approval to the Director of Navy Accounts.

3. An appropriate reference to this Navy Order is to be made against Naval Financial Regulations and Instructions, Articles 41 and 118.

(407/212/508.)

212.

LIFE-SAVING EQUIPMENT—SLEEVES AND TORCHES FOR INFLATABLE LIFE BELTS.

With reference to Navy Order 126 of 1944, it has now been decided that *all* personnel serving afloat are to be supplied with sleeves, torches, and batteries for use with their inflatable lifebelts, and necessary supplies for the purpose will be forwarded to H.M.A. Ships as soon as possible. The equipment is to form an integral part of the inflatable lifebelt.

2. Demands for requirements to complete the inflatable lifebelts in possession of personnel in H.M.A. Ships are to be forwarded to—

Victualling Store Officer, Sydney—for sleeves,
Superintending Naval Store Officer, Sydney—for torches,
batteries, and bulbs,

and the demands are to provide for 10 per cent. spares to meet replacements and for the purpose of outfitting personnel who may arrive on board without the equipment, observing that the requirements of personnel serving afloat will receive priority of supply.

3. Shore establishments are to demand initial supplies sufficient to provide for issue to personnel when drafted afloat. The quantity to be demanded and maintained is to be based on normal draftings afloat for a three months' period.

4. The sleeves are to be accounted for in the Clothing Account, Form A.S. 83, Part 2, in the same manner as for the belts, *vide* Navy Order 163 of 1939.

5. Torches, batteries, and bulbs are to be dealt with as personal issue, particulars being noted in Service Certificates or other appropriate records—*vide* Navy Order 163 of 1939. Bulk supplies of these items should be taken on charge in the Naval Store Account in the usual manner, but the items are to be issued outright as required and not recorded on permanent loan lists.

(612/231/292.)

213.

MOSQUITO NETS.

In future, areas north of 29 deg. south latitude are to be regarded by Commanding Officers as requiring the use by Naval personnel of mosquito nets.

2. Where mosquito nets may be regarded by Commanding Officers as necessary in other areas, issues are not to be authorized without the approval of the Naval Board.

3. The above decision is applicable only to personnel serving on shore. Special mosquito nets for use on board H.M.A. Ships are dealt with in Navy Order 143 of 1943.

(612/232/99.)

214.

SUPPLY OF CIVILIAN CLOTHING TO MEMBERS OF THE NAVAL FORCES ON DISCHARGE.

With reference to Navy Order 390 of 1943, should it not be possible, due to abnormality of build, satisfactorily to outfit any personnel, on discharge, from the complete range of stock size diagonal serge jackets and trousers, the necessary garments may be obtained, subject to the special approval of the Commanding Officer, by purchase from the Departmental contractor for ratings' made-to-measure uniforms. Such special purchases are to be advised to the Director of Victualling.

2. Demobilization Depots are to ensure that diagonal serge jackets and trousers, also civilian hats, are stocked in the complete range of sizes in sufficient quantities to meet requirements of discharged personnel.

(434/201/3526.)

215.

CONSERVATION OF SHEETS AND PILLOW SLIPS.

There is an acute shortage of cotton in Australia, and steps should be taken by all responsible officers to ensure that every endeavour is made to conserve the life of cotton goods, such as sheets and pillow slips.

(612/235/833.)

216.

SHIPMENT OF MINING STORES—CASE MARKINGS.

It has been decided to introduce the following distinctive marking for packages containing Mining Stores:—

Two blue bands, and the letter "M" stencilled in blue on them.

2. The above instruction refers to Naval Armament Stores only, and not to Minesweeping Stores or Naval Stores for Controlled Mining.

3. Consolidated Orders and Regulations, Article 526, paragraph 10 (e), will be amended in due course.

(1924/5/62.)

217.

ACCOUNTS FOR PROVISIONS—NECESSITY FOR PROMPT PAYMENT.

Delays in settlement of accounts for supplies of fresh provisions to H.M.A. Ships have recently come under notice.

2. To avoid such delays in future, claims should be prepared and passed promptly by ships concerned at the end of each month. Where a ship is proceeding to sea and is not likely to return to port before the end of the month of supply, Account (A.S.22) for supplies received to date is to be forwarded to the Paying Authority, if practicable, before sailing.

3. Claim should be prepared from ship's records if necessary. Care should be taken to record the passing of the claim in the provision account, to obviate the possibility of duplicate payment in cases where the firm's invoice is not available when the claim (A.S.22) is prepared.

(401/201/3956.)

218.

CORRIGENDUM.

Navy Order 169 of 1944 (4th item) is to be amended as follows:—

<i>Item.</i>	<i>R.N. Allowance as per A.F.O's.</i>
Blankets . .	4 No. per officer. 3 No. per rating.

(612/235/860.)

RESTRICTED.(FOR OFFICIAL USE ONLY.)

Commonwealth Navy Orders.

Navy Office, Melbourne,

2nd May, 1944.

The following Orders, having been approved, are hereby promulgated for information and guidance, and necessary action.

By direction of the Naval Board,

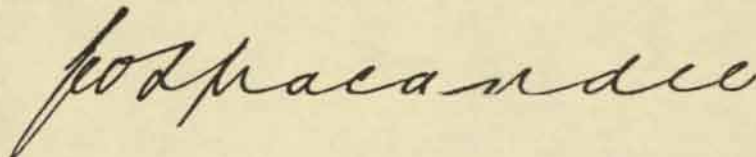

Secretary.

*The Rear-Admiral Commanding H.M.A. Squadron,
and Commanding Officers of H.M.A. Ships,
Officers in Charge of H.M.A. Naval
Establishments. and others concerned.*

TABLE OF CONTENTS.

No.	Subject.
219.	Chevrons for War Service.
220.	Compulsory Making of Wills.
221.	Advancement of Ratings Trained in Combined Operations.
222.	Form A.M.177G. Medical Store Account for Scale "C" Medical Stores.
223.	Report of Survey on Provisions or Other Victualling Stores—Form A.S.330—Rendition by Tenders.
224.	Special Clothing Issues for Personnel in Forward Island Areas.
225.	Forms.
226.	Corrigendum.

219.

CHEVRONS FOR WAR SERVICE.

It has been approved for personnel to wear chevrons for war service.

2. These chevrons are of one pattern and will be in red, the axis being three-quarters of an inch in length, and are to be worn on the right forearm.

3. They are to be issued on the basis of one for each complete year of service. A recipient will become eligible for the first chevron at the end of his first completed year of war service and so on.

4. A first issue of two sets of chevrons will be made gratuitously to all personnel who have completed at least one year of service.

5. Supplies are in course of procurement and should be requisitioned from Royal Edward Victualling Yard, Sydney.

6. The issue of chevrons is to be noted on the Service Certificates of all personnel.

(416/201/1033.)

(This Order will be reprinted for posting on Notice Boards.)

220.

COMPULSORY MAKING OF WILLS.

Attention is directed to Navy Order 47 of 1943 regarding compulsory making of wills by Royal Australian Naval personnel.

2. All officers and ratings who have not already completed wills are to be instructed to do so forthwith.

3. So far as ratings are concerned, a check of Certificates of Service should be made. The names of members whose Certificates do not contain the notation "Will made" should be listed and the ratings concerned required to complete wills. When made, all such outstanding wills are either to be forwarded to Navy Office for safe custody or advice furnished as to their location.

4. Wills should be completed by new entrants immediately upon final entry. Those collected during a month for custody by the Department are to be forwarded to Navy Office at the end of the month. Lists of wills made and lodged elsewhere should be forwarded to Navy Office at the same time.

(453/205/1462.)

221.

ADVANCEMENT OF RATINGS TRAINED IN COMBINED OPERATIONS.

The following amendments should be made to Navy Order 449 of 1943:—

Paragraph 2 (b)—After the word "seaman" first occurring, add the words "including four months' sea service."

Add new paragraph 2 (c)—An ordinary seaman who has not completed four months' sea service including time allowed under paragraph 4, is only eligible to be advanced to Acting Able Seaman on the completion of twelve months' service as an Ordinary Seaman. Confirmation and antedating in respect of time gained in accordance with (a) and (b) may be effected however on completion of four months' sea service.

Present paragraph 2 (c) is to be renumbered 2 (d).

Paragraph 3—Under the heading "To Leading Seaman" add to clause (c):—

"(Owing to limited opportunities for confirmation a Form A.S.207 may be rendered for Acting Able Seaman)".

(568/202/943.)

222.

FORM A.M.177G. MEDICAL STORE ACCOUNT FOR SCALE "C" MEDICAL STORES.

Account Form A.M.177G has been prepared for use in accounting for scale "C" outfit of medical stores.

2. Ships and establishments carrying scale "C" are to return all unused copies of Forms A.M.177 or A.M.57W, X, and Y to the Medical and Dental Store Officer and demand Form A.M.177G in lieu.

3. Current accounts at present in use are not to be destroyed; they are to be continued to due date of rendition and the credit entry of remaining stores then transferred to line 1 of Form A.M.177G.

(612/214/1175.)

223.

REPORT OF SURVEY ON PROVISIONS OR OTHER VICTUALLING STORES—FORM A.S.330—RENDITION BY TENDERS.

With reference to Navy Order 127 of 1944, Reports of Survey on provisions and other victualling stores in tenders are invariably to be rendered to Navy Office through the parent ship.

(612/243/475.)

224-226

4

224.

SPECIAL CLOTHING ISSUES FOR PERSONNEL IN FORWARD ISLAND AREAS.

In future, personnel drafted to forward island areas other than Port Moresby are to be outfitted by Drafting Depots with the special clothing referred to in Navy Order 623 of 1943, viz., heavy boots, mosquito net, ground sheet and long khaki clothing.

2. Navy Order 623 of 1943 is to be amended accordingly.

(434/210/163.)

225.

FORMS.

The under-mentioned form has been introduced for use in the R.A.N. First supply will be issued, without demand, by the Superintending Naval Store Officer, Sydney:—

A.S.1161.—“Report of Defects in Torpedoes and their accessories.”

(480/202/4351.)

2. The under-mentioned forms have been introduced for use in the R.A.N. First supply will be effected, on demand, by the Superintending Naval Store Officer, Sydney:—

A.S.1129z.—“Record of Issue of 1939-43 and/or Africa Star.”

(480/202/4550.)

A.O.50z.—“Guard Book for Form O.50.”

A.O.426z.—“Guard Book for Form O.426.”

(480/202/4515.)

3. The under-mentioned form has been revised and supply will be effected, on demand, by the Medical and Dental Store Officer, Sydney, when stock of the existing form has been exhausted:—

A.M.165z.—“Demand, Receipt or Supply Form for Medical and Dental Stores and Instruments.”

(480/201/3208.)

226.

CORRIGENDUM.

The following amendment is to be made to Navv Order 528 of 1943:—

Paragraph 2.—Delete words “is cancelled” and substitute “paragraph (b) is cancelled”.

(568/202/798.)

By Authority: H. E. DAW, Government Printer, Melbourne.

RESTRICTED.

(FOR OFFICIAL USE ONLY.)

Commonwealth Navy Orders.

Navy Office, Melbourne.

9th May, 1944.

The following Orders, having been approved, are hereby promulgated for information and guidance, and necessary action.

By direction of the Naval Board,

Secretary.

*The Rear-Admiral Commanding H.M.A. Squadron,
and Commanding Officers of H.M.A. Ships,
Officers in Charge of H.M.A. Naval
Establishments, and others concerned.*

TABLE OF CONTENTS.

No.	Subject.
227.	Arrangements in Respect of the Agreement between U.K. and Australian Governments for H.M. Ships Transferred to R.A.N. for Manning.
228.	R.A.N.E. Officers—Navigational Course to Qualify for Command of an A.M.S.
229.	Deaths—Information to be forwarded where Personnel die from Disease or Injury.
230.	Payment of Contractors' Claims in Connexion with Funerals.
231.	Protective Clothing.
232.	Binoculars for D.E.M.S.
233.	Access to Compartments Situated Below the Waterline, Which are to be Manned at Sea—Alterations and Additions.
234.	Variations in Kit—Small Blue Drill Kit Bags and Suit Cases.
235.	Warranty Period of Canned Provisions.

C.4512/44.

227.

ARRANGEMENTS IN RESPECT OF THE AGREEMENT BETWEEN U.K. AND AUSTRALIAN GOVERNMENTS FOR H.M. SHIPS TRANSFERRED TO R.A.N. FOR MANNING.

With reference to Confidential Commonwealth Navy Order 51 of 1944, where the accounts of any of the ships manned by the Royal Australian Navy on behalf of the Admiralty are carried in one of H.M.A. Ships or Establishments, cash advances made to them are to be regarded as an advance to the parent ship and charged to Naval Appropriations Suspense Account.

2. The amount involved and included in the relative Form A.S. 17 prepared in the parent ship will be chargeable to the Permanent Force Pay vote R.A.N., and all adjustments necessary, as regards the allocation of charges between the Admiralty and Royal Australian Navy, will be effected in Navy Office.

3. All expenditure other than that included in ships' ledgers should continue to be charged to Admiralty Account.

(401/217/919.)

228.

R.A.N.R. OFFICERS—NAVIGATIONAL COURSE TO QUALIFY FOR COMMAND OF AN A.M.S.

With reference to Navy Order 94 of 1942, the two weeks' navigational course and examination, required as qualification for command of an A.M.S. by R.A.N.R. Officers and undertaken on conclusion of Senior Reserve Officers' Course in H.M.A.S. *Cerberus*, is in future to be carried out in H.M.A.S. *Penguin*.

(600/209/146.)

229.

DEATHS—INFORMATION TO BE FORWARDED WHERE PERSONNEL DIE FROM DISEASE OR INJURY.

Delay has been occasioned in some cases in settling claims for pensions made by dependants of deceased members, due to insufficient information being given in the telegram or message reporting death.

2. Eligibility for a pension in certain cases is determined according to whether death is due to an injury or disease which was attributable to or aggravated by the conditions of the Naval Service of the deceased member. A pension is not payable in respect of death—

- (i) due to the serious default or wilful act of the member;
- (ii) arising from intentionally self inflicted injuries; or
- (iii) arising from, or from any occurrence happening during the commission of any serious breach of discipline by the member;

(Vide Navy Order 615 of 1943, paragraph 4 (e)).

3. The Repatriation Commission is unable to proceed with claims for pensions made by widows and other dependants until it is furnished with full information of the circumstances surrounding the death, in accordance with paragraph 2, and it is important therefore, that telegrams or messages should contain this information together with all other appropriate advice, e.g., in cases of death due to an accident or injuries sustained ashore—

- (a) whether the member was proceeding to or from place of employment at the time;
- (b) whether he was on leave; if so, the date of commencement and expiry of such leave;
- (c) whether a Board of Inquiry is to be held and the proposed date of same.

4. The finding of the Board of Inquiry should be advised by signal as soon as available.

5. It is also essential that the date of death be clearly stated in every case.

6. Navy Order 41 of 1943 is hereby cancelled.

(446/201/732.)

230.

PAYMENT OF CONTRACTORS' CLAIMS IN CONNEXION WITH FUNERALS.

With reference to paragraph 2 of Navy Order 553 of 1943, claims by contractors in connexion with funeral expenses of Naval personnel should, after certification as to correctness of the services, be forwarded in future to the Directorate of Graves Registration, Department of the Army, Victoria Barracks, Melbourne, for settlement.

(401/201/4217.)

231.

PROTECTIVE CLOTHING.

In order to prevent so far as is possible the contraction of malaria by Naval personnel and to reduce the risk of establishing endemic areas of malarial infection on the mainland of Australia, the following instructions are to be strictly carried out in the Royal Australian Navy:—

- (a) In the malarious area as defined in Navy Order 275 of 1943, paragraph 1 (a), and in the military training area adjacent to Cairns, protective clothing is to be worn at all times, both by base personnel and by sea-going personnel attached to small craft such as H.D.M.L's. and Fairmiles.
- (b) In the potentially malarious area as defined in Navy Order 275 of 1943, paragraph 1 (b), and including the township of Cairns, tropical rig is permissible during daylight hours, but protective clothing must be worn during the period commencing half an hour before sunset and extending half an hour after sunrise.
- (c) At sea, tropical rig is permissible in Cruisers, L.S.I's. Destroyers and A.M.S. Vessels, provided protective clothing is worn when landing in the area mentioned in sub-paragraph (a) above, either by day or night, and in the area mentioned in sub-paragraph (b) above, at night. Boats' crews running inshore are to wear protective clothing during the period commencing half an hour before sunset and extending half an hour after sunrise.

(516/201/633.)

232.

BINOCULARS FOR D.E.M.S.

Attention is drawn to the allowances of binoculars for Defensively Equipped Merchant Ships as recently revised by Admiralty, vide C.A.F.O. 673/43.

2. In addition to the main stocks of binoculars for D.E.M.S. held by the Officer-in-Charge, Naval Store Depot, Darling Island, Sydney, small stocks of binoculars for D.E.M.S. are held at Fremantle and Melbourne to enable replacement of defective glasses in D.E.M.S. to be effected without delay, the defective glasses being repaired as necessary by the Base Ordnance Staff (Optical), and retained in stock.

3. Endeavour should be made to arrange provision where practicable of at least one pair of 7 x 50 type binoculars to D.E.M. Ships.

(670/201/808.)

233.

**ACCESS TO COMPARTMENTS SITUATED BELOW THE WATERLINE,
WHICH ARE TO BE MANNED AT SEA—ALTERATIONS AND
ADDITIONS.**

The requirements of A.F.O. 6018/43 are to be followed in H.M.A. ships in commission where applicable.

(603/247/1745.)

234.

**VARIATIONS IN KIT—SMALL BLUE DRILL KIT BAGS AND SUIT
CASES.**

The following variations in kits, applicable for the period of hostilities, have been approved:—

Small Blue Drill Kit Bags.

1 No. small blue drill kit bag is added to the optional kits of ratings dressed in the uniform of classes I and III.

The addition of this article to the optional kit of class II was promulgated in Navy Order 258 of 1943.

Suit Cases.

The small suit case provided for in the optional kits of classes II and III is deleted, except for Petty Officers.

2. Naval Financial Regulations and Instructions, Article 46, is to be noted accordingly.

(516/201/584.)

235.

WARRANTY PERIOD OF CANNED PROVISIONS.

The warranty expiry dates for those canned provisions referred to in paragraph 3 of Navy Order 68 of 1944 have not yet been definitely determined, but provision has been made in the contracts arranged for supply of such items for the warranty expiry dates set out hereunder to be applicable. Should objection thereto be raised by any contractor, however, the matter will be the subject of negotiation between Commonwealth Food Control and the contractor concerned:—

(a) Canned Pineapple and Pineapple Products—twelve months from date of manufacture.

(b) Canned Gooseberries, Strawberries, Raspberries, Loganberries, Plums, and Blackcurrants—twelve months from 31st December.

(c) Canned Cherries—twelve months from 31st January.

(d) Canned Blackberries—twelve months from 31st March.

2. Pending notification of any variation, the warranty periods indicated above are to apply.

3. As regards tomato and fruit pulps, it is unlikely that any warranty conditions will be applicable to supplies obtained.

(668/216/426.)

RESTRICTED.(FOR OFFICIAL USE ONLY.)

Commonwealth Navy Orders.

Navy Office, Melbourne,

16th May, 1944.

The following Orders, having been approved, are hereby promulgated for information and guidance and necessary action.

By direction of the Naval Board,

J. P. Macandee
Secretary.

*The Rear-Admiral Commanding H.M.A. Squadron,
and Commanding Officers of H.M.A. Ships,
Officers in Charge of H.M.A. Naval
Establishments, and others concerned.*

TABLE OF CONTENTS.

No.	Subject.
236.	H.M.A.S. "Kuranda."
237.	Accounts—R.A.N. Destroyers.
238.	Captain of Heads Allowance.
239.	Correspondence Orderlies and Postmen.
240.	Suppressive Treatment (Prophylaxis) for Malaria with Atebrin.
241.	Reduction of Kits in H.M.A. Ships and Shore Establishments.
242.	Claim Forms for Compensation for Total Loss of Uniform Clothing—Ratings—Introduction of Forms A.S.103y and A.S.103z.
243.	Stretcher Cots—Pattern 474—Supply.
244.	Naval Store Accounting Procedure—Frigates.
245.	Storage of Oilskin Clothing and Rubber Sea Boots.
246.	Amendment of Form A.S.151—Consumable Naval Store Ledger Sheets.
247.	Books and Forms.

C.4802/44.

236.

H.M.A.S. "KURANDA."

The Naval Establishment at Cairns was commissioned as H.M.A.S. *Kuranda* on 8th May, 1944.

(404/201/652.)

237.

ACCOUNTS—R.A.N. DESTROYERS.

The accounts of R.A.N. Destroyers attached to the Eastern Fleet have been transferred to H.M.S. *Highflyer*.

2. Accountant Officer (D) R.A.N. Eastern Fleet is base officer for Destroyers. Signals should be addressed direct to him, and correspondence to—

"Accountant Officer (D) R.A.N. Eastern Fleet, H.M.S. *Highflyer*, C/o British Fleet Mail."

3. The functions of the R.A.N. Accountant Officer, Colombo, are—

- (a) Base Office for A.M.S. Vessels and pool,
- (b) Drafting Office for Destroyers and A.M.S. Vessels,
- (c) R.A.N. Education Centre for Eastern Fleet.

4. Mails for personnel with no fixed address should be sent C/o R.A.N. Accountant Officer, Colombo.

(1804/2/84.)

238.

CAPTAIN OF HEADS ALLOWANCE.

Naval Financial Regulations and Instructions, Article 73, clause 82, limits the payment of this allowance.

2. In future, the allowance is to be paid only in ships where the complement is greater than fifty, including officers.

3. The allowance is not to be stopped from any rating at present in receipt thereof, while he continues to perform the duty, but paragraph 2 is to be observed for ratings detailed in future.

(407/201/1066.)

239.

CORRESPONDENCE ORDERLIES AND POSTMEN.

With reference to C.O.R., Article 329, and K.R. and A.I., Article 1095, Commanding Officers are to ensure that, with a view to safeguarding official correspondence—

- (a) Postmen, orderlies and despatch riders do not carry letters loose in their hands or pockets, but are provided with a stout bag or case to contain loose correspondence.
- (b) Orderlies and despatch riders do not pay unauthorized visits to shops, cafes, &c., on private errands when carrying official correspondence.

(1850/2/360.)

240.

SUPPRESSIVE TREATMENT (PROPHYLAXIS) FOR MALARIA WITH ATEBRIN.

In order to institute the administration of suppressive atebtrin in highly malarious areas on seven days of each week, the following amendments are to be made to Navy Order 603 of 1943:—

- (1) Paragraph 7 (b). The words "on six days of each week" are to be deleted.
- (2) Paragraph 7 (c). The words "for six days of each week, excluding Sunday" are to be deleted and the word "daily" inserted in lieu.
- (3) Paragraph 7 (e) (i). The words "for six days each week" are to be deleted and the word "daily" inserted in lieu.

2. Steps are to be taken to ensure that all personnel concerned are made aware of this change and that the instruction on the lid of the tin, individual atebtrin, is obsolete. Amendment of instruction will be made on the tins when new stocks are issued.

(527/201/840.)

241.

REDUCTION OF KITS IN H.M.A. SHIPS AND SHORE ESTABLISHMENTS.

It is necessary under existing conditions that the quantity of kit taken on board H.M.A. Ships by personnel should be reduced to a minimum for, apart from the fact that stowage space is limited, the accumulation of excessive or non-essential articles creates a potential fire risk.

2. For these reasons suit cases have been deleted from the optional kits of all ratings except C.P.O's and P.O's, and the small blue drill kit bag has, in consequence, been made an optional item for all ratings. These variations of kit will apply in ships and shore establishments for the period of hostilities only.

3. Further, as many articles of uniform continue to be in short supply and the situation in this respect is not likely to improve in the near future, it is desired that no article of kit in excess of the authorized quantity should be maintained by or be in the possession of ratings, whether ashore or afloat, unless exceptional local reasons justify that course in the view of the Commanding Officer.

4. Navy Order 331 of 1943 is cancelled.

(516/201/584.)

(This Order will be reprinted for posting on Notice Boards.)

242.

CLAIM FORMS FOR COMPENSATION FOR TOTAL LOSS OF UNIFORM CLOTHING—RATINGS—INTRODUCTION OF FORMS A.S.103y AND A.S.103z.

New forms—A.S.103y and A.S.103z—have been instituted in the R.A.N. for use in connexion with the preparation and finalization of claims for compensation for *total* loss of uniform clothing sustained by ratings as a result of a Service casualty.

2. Initial supplies of the forms are being despatched to all ships and depots concerned without demand and are, on receipt, to be brought into use.

3. Any further supplies of the forms required should be demanded in the usual manner from the Superintending Naval Store Officer, Sydney.

(480/201/3148.)

243.

STRETCHER COTS—PATTERN 474—SUPPLY.

With reference to A.F.O. 2803/42, stocks of pattern 474 stretcher cots are now available, and demands for requirements should be forwarded to the Superintending Naval Store Officer, Sydney.

2. An equivalent number of canvas cots is to be returned to store on receipt of the pattern 474 stretcher cots.

(612/235/917.)

244.

NAVAL STORE ACCOUNTING PROCEDURE—FRIGATES.

The modified system of accounting for Naval stores in Frigates and Corvettes as indicated in A.F.O. 5516/43, is not to be adopted for use in the R.A.N.

2. The normal system of accounting for Naval stores in accordance with B.R. 4—Naval Storekeeping Manual—will continue to be installed in H.M.A. Frigates at present under construction.

3. The attention of responsible officers is again drawn to the necessity for the efficient performance of all duties in connexion with Naval store procedure and accounting. It is pointed out that the essential purpose of wartime store accounting is the production of data to enable correct replenishment demands to be prepared, and therefore no ship can be considered efficient if her store accounts are not up to date and do not present at all times such data.

(612/212/2944.)

215.

STORAGE OF OILSKIN CLOTHING AND RUBBER SEA BOOTS.

The attention of all concerned is again drawn to the necessity for the proper care of oilskin clothing and rubber sea boots. Under existing conditions, the procurement of adequate supplies of these important items is a particularly difficult matter, and it is imperative that losses due to carelessness in storage be avoided.

2. The instructions regarding the storage of oilskin clothing and rubber sea boots set out in Articles 12 and 13 of Chapter 12 of the Manual of Victualling, have been amplified in Navy Order 530 of 1943, and Commanding Officers are to ensure their observance to the utmost extent possible.

(612/243/700.)

246.

AMENDMENT OF FORM A.S.151—CONSUMABLE NAVAL STORE LEDGER SHEETS.

Ledger Form A.S.151, for recording receipts and issues of consumable Naval stores, has been revised and is being reprinted as under:—

Date.	Received.	Issued.	Remains	Voucher No.	Date.	Received.	Issue d.	Remains	Voucher No.
						B.F.			
Total				Remains Crd. Fwd.	Total				Remains Crd. Fwd.

2. Revised Forms will be issued on demand when stocks of the existing sheets are exhausted. Until receipt of these, all ledgers and stock of existing ledger pages held by H.M.A. ships and establishments are to be amended suitably on both sides of the sheet.

3. Ledger-keepers are now to total "Received" and "Issued" columns, thus proving the extensions in the "Remains" column. The "Remains" only, however, are to be carried forward.

(480/202/4575.)

247.

BOOKS AND FORMS.

The under-mentioned publications have been distributed. Further copies of B.R.762, 765 and 766 are being obtained to complete distribution:—

B.R.150 (Late B.R.150B).—Naval Manual of Aircraft Recognition Amendment No. 3.

(A.F.O's. 4882 and 5416/43.)
(571/202/1646.)

B.R.317 (21).—Mining Drill Book—Preparation of the Mark XIX S. Mine Assembly No. 2.

(A.F.O. 1389/43.)
(571/202/1628.)

B.R.321/43.—Establishment of Naval Stores for Engineering Purposes.

(A.F.O. 5293/43.)
(571/202/1890.)

B.R.372.—Establishment of Naval Stores for Minelaying Lighters, 1939—Errata No. 5.

(A.F.O. 4507/43.)
(571/202/1263.)

B.R.373.—Establishment of Naval Stores for *Hunt* Class Destroyers—List of Errata No. 5.

(A.F.O. 4368/43.)
(571/202/1408.)

B.R.633 (3), 1943.—Instructions for Depth Charge, Mine, Paravane Minesweeping and Ahead-Thrown Weapons Trials, including Pamphlets B.R.633 (3) *a, b, c, d, e, and f.*

(A.F.O. 5793/43.)
(571/202/1640.)

B.R.664.—King's Regulations and Orders for the Army. Amendments Nos. 32, 33, 34 and 35.

(A.F.O's. 4882 and 5522/43.)
(584/203/126.)

B.R.762.—Jane's Fighting Ships, 1942.

(A.F.O. 4507/43.)
(571/202/1826.)

B.R.765/43.—Combined Operations Gunnery Instructions.

(A.F.O. 5794/43.)
(571/202/1693.)

B.R.766/43.—Combined Operations Signal Book.

(A.F.O. 5419/43.)
(571/202/1693.)

B.R.833/43.—Handbook for the 4-in. Q.F. "A" Marks V, V* and Q.F. Marks V**, V*** and VC Guns on High Angle, Marks III, III*, III** and IV Mountings.

(A.F.O. 4131/43.)
(571/202/1816.)

B.R.836/43.—Training of Coincidence Rangefinders at Sea.
(571/202/1900.)

B.R.859/43 (Supersedes O.U.5531).—Regulations for Maintenance of 21-in. Mark VIII and VIII** (Excluding certain Periodical Routines for 21-in. Mark VIII** Torpedoes).

(A.F.O. 5795/43.)
(571/202/1882.)

B.R.861.—Drill for the Fuzekeeping Clocks, Marks II and II*, and Admiralty Fire Control Clock, Mark III*.

(A.F.O. 5294/43.)
(571/202/1854.)

B.R.866/43.—Instructions for Operation and Maintenance of Lethal Gear for Mk. IV Balloons Afloat.

(571/202/1891.)

B.R.906 (Late C.B.4067).—Handbook for Admiralty Fire Control Tables, Marks VI and VI*, and Admiralty Fire Control Clock, Mark VI—1940.

(A.F.O. 4640/43.)
(571/202/1893.)

B.R.910 (Late C.B.1975).—Instructions for Analysing Low Angle Gunnery Practices, Battleships, Battle Cruisers, Cruisers and Aircraft Carriers.

(A.F.O. 4640/43.)
(571/202/1899.)

B.R.913 Series (Late C.B.4028 Series).—Handbook of the Fuzekeeping Clock and Associated Equipment:—

B.R.913 (1).—Introduction and Drill at the Fuzekeeping Clock, 1939.

B.R.913 (2).—The Fuzekeeping Clock, Marks II and III, 1939.

B.R.913 (2) (1).—Addendum No. 1 to B.R.913 (2).

B.R.913 (3).—The Rangefinder/Director, Marks II and III (Electric type).

The Rangefinder/Director, Marks IV and V, IV* and V* (Mechanical type) 1939.

B.R.913 (3) (1).—Addendum No. 1 to B.R.913 (3).

B.R.913 (4).—The Gyro Roll Corrector, Marks III and VII—1939.

B.R.913 (5).—The Fire Control Box, Marks II and III—1939.

B.R.913 (6).—Electrical Transmission, 1939.

B.R.913 (7).—The Rangefinder Director, Marks IV*, V*, V**, 1943.

B.R.913 (8).—3-Man Rangefinder converted to H.A. Control, 1943.

(A.F.O. 4640/43.)
(571/202/1857.)

B.R.913 (9).—The Rangefinder Director, Marks IIW and IIIW.

(A.F.O. 5151/43.)
(571/202/1857.)

B.R.913 (11).—The Fire Control Box, Marks VI and VI*.

(A.F.O. 4880/43.)
(571/202/1857.)

B.R.916 (Late C.B.4167).—Handbook for the 4.7-in. Mark XI Gun on the Twin Mark XX Mounting, 1942.

(A.F.O. 4640/43.)
(571/202/1896.)

O.U.5420.—Rate Book, Victualling and Marine Stores—Errata No. 3.

(A.F.O. 5422/43.)
(571/203/2449.)

Air Diagram No. 2376.—Travelling Lampsight.

Air Diagram No. 2185.—Avoiding Action.

Air Diagram No. 2186.—Straight Running Technique.

Air Diagram No. 2187.—Gyro Angling Technique.

(A.F.O. 1499/43.)
(571/202/1892.)

O.N.1, 220M.—Axis Submarine Manual.

(571/201/4087.)

2. The under-mentioned publication has been removed from B.R.1 (Catalogue of Books of Reference) and no further issues will be made:—

B.R.315.—History of British Minesweeping in the War of 1914-18.

(A.F.O. 5417/43.)
(571/202/1650.)

3. The under-mentioned publication is now obsolete and is to be deleted from B.R.1 and A.P. (N) 1—Establishment of Air Publications:—

B.R.631.—Warships at a Glance.

(A.F.O. 6054/43.)
(571/202/1594.)

By Authority: H. E. DAW, Government Printer, Melbourne.

RESTRICTED.

(FOR OFFICIAL USE ONLY.)

Commonwealth Navy Orders.

Navy Office, Melbourne,

23rd May, 1944.

The following Orders, having been approved, are hereby promulgated for information and guidance, and necessary action.

By direction of the Naval Board,

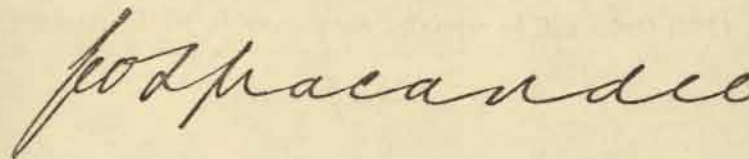

Secretary.

*The Rear-Admiral Commanding H.M.A. Squadron.
and Commanding Officers of H.M.A. Ships.
Officers in Charge of H.M.A. Naval
Establishments, and others concerned*

TABLE OF CONTENTS.

No.	Subject.
248.	Higher Educational Test, October, 1943.
249.	Radar Ratings.
250.	Outfit Gratuities on Change of Class of Uniform.
251.	Rendering Mines Safe—Employment of Personnel other than Officers.
252.	Mines Rendered Safe—Disposal.
253.	Fuzes, Time, on Board H.M.A. Ships—Annual Percentage Landing in Wartime.
254.	Housing Oerlikon Guns Fitted Mk. XIV Gyro Sights.
255.	Form N.A.5 Consecutive Number of Paid Voucher to be Inserted by Paying Office.

248.

HIGHER EDUCATIONAL TEST, OCTOBER, 1943.

Navy Order 156 of 1944 is to be amended as follows:—Add "Qualified for Warrant Rank" against the name of Petty Officer Writer John M. Hare, O.N. 23082.

(465/204/667.)

249.

RADAR RATINGS.

With reference to Navy Order 519 of 1943, the provisions of A.F.O. 5195/1943 have been adopted in the Royal Australian Navy from 15th May, 1944.

2. The necessary amendments to Naval Financial Regulations and Instructions will be made in due course.

(463/210/95.)

(This Order will be reprinted for posting on Notice Boards.)

250.

OUTFIT GRATUITIES ON CHANGE OF CLASS OF UNIFORM.

Consequent upon revision of prices of clothing, the amounts of outfit gratuities set out in paragraph 1 of Navy Order 548 of 1943 have been reduced as under from 1st May, 1944:—

	£	s.	d.
(a) to petty officers dressed as seamen on promotion to chief petty officer	12	15	3
(b) to petty officers, with one year's service as such and confirmed in that rating, required to change from Class II to Class III uniform ..	12	8	0
(c) to other men on transfer to rating for which a change of uniform to Class III is required and	12	3	6
(d) to other men on transfer to ratings for which a change of uniform to Class II is required ..	7	12	6

2. The necessary amendment of Naval Financial Regulations and Instructions, Article 51, will be promulgated in due course; in the meantime Article 51 is to be suitably endorsed.

3. Navy Circular No. 537 dated 29th April refers.

(434/201/3540.)

251.

RENDERING MINES SAFE—EMPLOYMENT OF PERSONNEL OTHER THAN OFFICERS.

Instances have been reported where ratings, qualified in R.M.S. and B.S. procedure, have been employed in rendering mines safe although R.M.S. and B.S. officers have been available, either in the Command concerned, or at adjacent ports. This is often due to the fact that these officers are employed on other duties such as diving. It is emphasized that these duties are subsidiary to R.M.S. and B.S. and must not be allowed to interfere with this duty.

2. Ratings are not to be so employed without prior Naval Board approval unless in exceptional circumstances, when damage to important structures is feared, for example, when the Naval Officer-in-Charge concerned must be guided by the circumstances prevailing.

3. If no R.M.S. and B.S. officer is available, a signalled request for assistance should be made to the nearest command where an R.M.S. and B.S. officer is borne, repeated to the Naval Board. A list of ports where these officers are normally available is appended hereunder:—

Sydney	Brisbane
Darwin	Fremantle
Flinders Naval Depot	Townsville
Cairns	Newcastle
Thursday Island	Port Moresby
Hobart	Milne Bay (for forward areas)
Adelaide	

(549/201/139.)

252.

MINES RENDERED SAFE—DISPOSAL.

With reference to Navy Order 164 of 1943, when mine shells are not recovered and retained, the mechanism plates are to be retained, and in the case of British mines, are to be forwarded to the Officer-in-Charge, R.A.N. Mine Depot, Swan Island. All other cover, or access, plates, together with horns when applicable, are to be removed and dumped as convenient.

2. The mine shells, if not destroyed during burning out, are, if possible, to be dumped at sea, or alternatively rolled inland for a short distance.

3. This action is necessary if false reports of mines washed ashore are to be reduced, and will also obviate further reports on a mine already rendered safe being forwarded, in the event of a second mine being washed ashore in the vicinity of the first.

(549/201/139.)

253.

**FUZES, TIME, ON BOARD H.M.A. SHIPS—ANNUAL
PERCENTAGE LANDING IN WARTIME.**

It has been reported to the Naval Board that some uncertainty exists regarding the landing of time fuzes by ships in wartime, in accordance with Naval Magazine and Explosives Regulations, Article 301, Item 29.

2. Time fuzes are landed for the purpose of proof, and proof can only be carried out with a number of fuzes (a minimum of three) of the same lot. Ships are therefore to land approximately $\frac{1}{3}$ per cent. of their fuzes, the exact number being the nearest multiple of three above $\frac{1}{3}$ per cent. Each group of three is to be from a different lot number, and if the number to be landed does not permit of landing three from each lot on board, three from each of the earlier lots of each filler are to be selected.

3. Fuzes amongst those landed that have been fitted to shell in R.U. positions and/or have been "SET" are to be labelled to that effect.

(471/209/1338.)

254.

HOUSING OERLIKON GUNS FITTED WITH MK. XIV GYRO SIGHTS.

Oerlikon Guns fitted with Mk. XIV Gyro Sights should only be housed in horizontal position.

2. To ensure that vertical position is inoperative, the locking bolt hole may be plugged with lead by ship's staff if desired.

(490/212/1081.)

255.

**FORM N.A.5 CONSECUTIVE NUMBER OF PAID VOUCHER TO BE
INSERTED BY PAYING OFFICE.**

In view of the much greater use of Form N.A.5 occasioned by revised arrangements for payment of Traders' Accounts, it is necessary for additional references to appear in future on that form for the information and guidance of all concerned.

2. In future, the three copies of N.A.5 are to be forwarded to the office responsible for arranging payment. At that office the date of payment, Treasury consecutive number allotted by the paying office, and reference to the bank of credit are to be inserted on each copy in column 4 of the form. The original is to be retained, duplicate returned to the originator, and triplicate forwarded to Director of Navy Accounts.

3. Naval Account Regulations and Instructions, Article 225, and Form N.A.5 will be amended as requisite in due course.

(401/201/4265.)

By Authority: H. E. Daw, Government Printer, Melbourne.

RESTRICTED.

256—268

(FOR OFFICIAL USE ONLY.)

Commonwealth Navy Orders.

Navy Office, Melbourne,

30th May, 1944.

The following Orders, having been approved, are hereby promulgated for information and guidance and necessary action.

By direction of the Naval Board,

John Macandee
Secretary.

*The Rear-Admiral Commanding H.M.A. Squadron,
and Commanding Officers of H.M.A. Ships.
Officers in Charge of H.M.A. Naval
Establishments, and others concerned.*

TABLE OF CONTENTS.

No.	Subject.
256.	Naval Watchkeeping Certificates—Naval Reserve Officers.
257.	Confidential Reports Upon Naval Reserve Officers.
258.	Despatch of Personnel to Sydney for Medical Observation or Treatment Not Requiring Hospitalization.
259.	Use of Army Medical Facilities in Transfer of Invalids.
260.	H.M.A. Ships—Re-arming with 4-in. XIX Guns on H.A. L.A. XXIII* Mounting.
261.	20 M.M. Oerlikon—One Man Cocking Device.
262.	Industrial Gases—Cylinders for.
263.	Kits of Ratings Drafted to New Guinea, Darwin, Thursday Island or Other Forward Areas in the South-West Pacific.
264.	Issue of Mess Gear and Blankets to Personnel Travelling.
265.	Food Rationing and Food Economy—General Instructions.
266.	Food Coupons—Naval Personnel.
267.	Salvage of Condemned, Unserviceable, &c., Stores—Army Salvage Service.
268.	Books and Forms.

C.355

NAVAL WATCHKEEPING CERTIFICATES—NAVAL RESERVE OFFICERS.

It has been brought to notice that there has not been sufficient adherence to the Regulations and Instructions laid down for the granting of Watchkeeping Certificates. Very few of the Lieutenants who have attended navigation classes at Flinders Naval Depot could have been eligible for the award of either "full" or "restricted" Watchkeeping Certificates, and the majority could not have passed the examination required of them *before* promotion to the rank of Lieutenant, as they had no knowledge of the use of the sextant and could not have taken a meridian sight as required.

2. It has therefore been decided that a uniform standard of navigational knowledge shall be attained by Naval Reserve Officers before they are awarded a restricted Watchkeeping Certificate, irrespective of the type of ship in which they may be serving.

3. The standard to be attained will be that set out in Naval Reserve Regulations and Instructions (1940), Article 58, Section II—NAVIGATION—and no Officer is to be awarded the Restricted Watchkeeping Certificate unless he has attained not less than 60 per cent. of marks in this subject.

4. In this connexion attention is called to Admiralty Fleet Order 6000/42, paragraph 10 (adopted in the R.A.N. by Navy Order 538 of 1943), which reads as follows:—

"10. (a) The Naval Watchkeeping Certificate is to be worded as follows:—

' (Rank)(Name).....
is competent to take charge of a Watch at sea as a Lieutenant, and to perform efficiently the duties of that rank.'

(b) Where a Commanding Officer does not feel justified in awarding the Full Naval Watchkeeping Certificate as shown above, a Restricted Certificate may be awarded by the addition of a paragraph to the following effect:—

' This Certificate is granted for (insert class of vessel) only'.

(c) Where the additional paragraph referred to above is added, the Certificate will not be regarded as a Full Naval Watchkeeping Certificate, and the notation (W/K) will not appear against the Officer's name in the Navy List.

(d) Copies of Watchkeeping Certificates awarded are to be forwarded at the time of award to the Director of Naval Reserves and Naval Reserves Mobilization, or with the application for promotion if at the time of the award the Officer is due for promotion."

5. In all cases where the restricted Watchkeeping Certificate referred to above is awarded, the following note is also to appear at the foot of the Certificate:—"This Officer has passed the examination in Navigation as set out in Naval Reserve Regulations and Instructions (1940, Article 58, Section II—NAVIGATION) and has attained not less than 60 per cent. of marks in this subject"

6. Navy Orders 18 and 360 of 1942 are hereby cancelled.

(453/202/962.)

CONFIDENTIAL REPORTS UPON NAVAL RESERVE OFFICERS.

As some doubt appears to exist concerning the rendering of confidential reports upon Naval Reserve Officers when mobilized, the following instructions are promulgated for the information of authorities concerned.

(i) Reports are to be rendered upon all Naval Reserve Officers in accordance with Consolidated Orders and Regulations, Article 227, on all occasions as specified under the heading "SEA-GOING FORCES, Sections I to VI."

(ii) Confidential reports on Form S.206 are to be rendered upon Naval Reserve Officers on the following additional occasions:—

Officers Reported Upon.	When to be Rendered.
(a) Probationary Officers	On completion of three months' mobilized service from date of promotion from the lower deck or first appointment from shore. Special reference should be made to the fitness of the officer for confirmation in rank.
(b) Midshipmen	To reach Navy Office immediately prior to attaining the age of 19½ years. Special reference should be made to the Officer's fitness for promotion. If this report coincides with that required under clause (a), confirmation and promotion should be dealt with in the one report.
(c) Acting Sub-Lieutenant (or equivalent rank)	To reach Navy Office immediately prior to attaining six months' seniority. Special reference should be made to the Officer's fitness for promotion.
(d) Sub-Lieutenant (or equivalent rank)	To reach Navy Office immediately prior to attaining the necessary qualifying service for promotion to the rank of Lieutenant or Lieutenant (Provisional).

Officers Reported Upon.	When to be Rendered.
(e) All Officers	<p>On recommendations being made under following provisions:—</p> <p>A.F.O. 425/42—Accelerated promotion to Lieutenant rank.</p> <p>A.F.O. 4916/43—"Qualified" status (Full) and (Modified).</p> <p>A.F.O. 4240/42—Acting Lieutenant-Commander rank.</p> <p>Note (Special Form S.206D should be used for this report).</p> <p>A.F.O. 5998/42—Fighter Direction Officers (after six months' service).</p> <p>A.F.O. 1027/41—Grant of additional seniority for meritorious service.</p> <p>Navy Order 359 of 1943—Lieutenant-Commander rank, R.A.N.R. and R.A.N.V.R.</p>
(f) Warrant Officer and Commissioned Officer from Warrant Rank	<p>To reach Navy Office by 1st May and 1st November each year for officers who are recommended for promotion. (See also Naval Reserve (Sea-going) Regulations and Instructions, Articles 12.B and 12.D.)</p>

2. It is impressed upon Reporting Authorities that Forms S.2's should be rendered as early as possible on or after the occasions enumerated above.

3. Navy Order 360/43 is hereby cancelled.

(559/222/1209.)

258.

DESPATCH OF PERSONNEL TO SYDNEY FOR MEDICAL OBSERVATION OR TREATMENT NOT REQUIRING HOSPITALIZATION.

The attention of all Commanding Officers is directed to the provisions of Navy Orders 11 and 537 of 1943 which are frequently not being carried out. Naval personnel despatched to Sydney for medical reasons are to be forwarded, in the first place, to *Penguin*, and not to *Rushcutter*, except where the member obviously needs in-patient treatment in Canonbury or Naval Wing Hospitals.

2. Officers appointed to *Rushcutter* additional for ordinary reasons are not affected by this Order.

(527/211/2028.)

259.

USE OF ARMY MEDICAL FACILITIES IN TRANSFER OF INVALIDS.

Before sending invalids to their Home Ports or to another region under escort of a Sick Berth rating, Commanding Officers are to make inquiries of the Deputy Director of Medical Services in their particular State to ascertain the movement of Army Ambulance trains or parties (walking cases) under medical escort, in order that these facilities may be used for Naval invalids where practicable.

Medical care and attention can thus be obtained for them *en route* without the necessity of despatching a Sick Berth rating especially to care for them.

2. No objection is taken to the escort of invalids by a Sick Berth rating going on leave to or through cities to which the former are being transferred

(527/211/2040.)

260.

H.M.A. SHIPS—RE-ARMING WITH 4-IN. XIX GUNS ON H.A. L.A. XXIII* MOUNTING.

Four-in. Mark XXIII* mountings are now becoming available and certain A.M.S. vessels have already been so fitted.

2. All H.M.A. Ships which are still to be re-armed with a 4-in. H.A. L.A. gun in lieu of existing 4-in. L.A. or 12-pdr. H.A. L.A. mountings will be fitted with the 4-in. Mark XXIII* H.A. L.A. mounting at forthcoming refits.

3. Those ships which have already been re-armed with a 4-in. Mark XXIII H.A. L.A. mounting are to raise an alteration and addition item, classification A* to fit 4-in. Mark XXIII* H.A. L.A. mountings in lieu of existing 4-in. Mark XXIII H.A. L.A. mounting. This work is to be carried out at next refit.

4. Mark XXIII mountings displaced are to be allocated to Defensively Equipped Merchant Ships. No Mk. XXIII* mountings are to be mounted in Defensively Equipped Merchant Ships until stock of XXIII are exhausted.

5. The Commanding Officers of A.M.S. vessels are to letter this alteration and addition "B.L." in conformity with Confidential Commonwealth Navy Orders 50, 106 and 180 of 1943.

(490/203/1202.)

261.

20 M.M. OERLIKON—ONE MAN COCKING DEVICE.

A one man Cocking Device has been designed, which has considerable advantages over previous designs.

2. A dimensioned sketch and arrangement are shown on the appended diagram.

3. The fitting may be constructed and fitted by Ships' Staffs and Base Ordnance where desired by Ships' Officers.

4. This device is such that a man in the harness and a second man applying pressure to his shoulders can quickly and easily cock the gun.

(490/212/1020.)

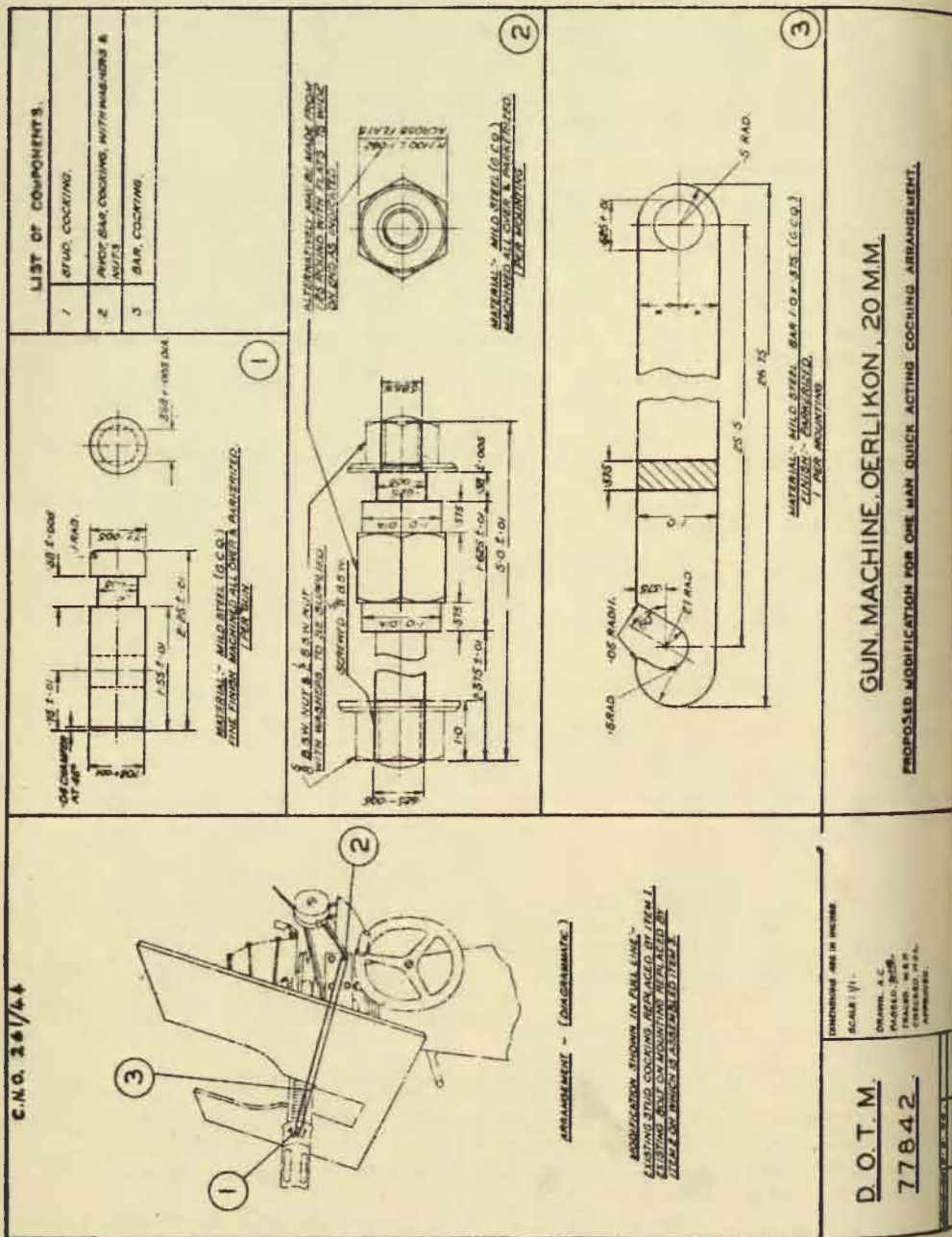

262.

INDUSTRIAL GASES—CYLINDERS FOR.

With reference to Navy Order 681 of 1943, reports indicating whether any of the missing cylinders are held are outstanding from a number of H.M.A. Ships and Establishments.

2. Rendition of the outstanding reports should be expedited.

(669/201/1040.)

263.

KITS OF RATINGS DRAFTED TO NEW GUINEA, DARWIN,
THURSDAY ISLAND OR OTHER FORWARD AREAS
IN THE SOUTH-WEST PACIFIC.

In view of the damaging effect of mould which accumulates on articles of kit stowed for lengthy periods in tropical areas, it has been decided that only minimum items of essential kit are, in future, to accompany ratings drafted to the above-mentioned forward areas for shore duties.

2. Details of such minimum kits, also other necessary articles required, are set out in the appended Schedules.

3. Ratings on draft who pass through Brisbane *en route* to those areas are to be instructed to leave in H.M.A.S. *Moreton* such items of their normal kit as are not included in the Schedules. In other cases, the surplus items are to be left in the Depot from which they are taking passage except that ratings who are drafted to Darwin and proceed through Adelaide are to leave surplus kits in H.M.A.S. *Torrens*.

4. A list of the articles so deposited for safe custody is to be prepared, checked and suitably recorded in a separate Baggage Register, a detailed receipt being given to the depositor by a responsible officer or a person authorized to act on his behalf.

5. Surplus items of normal kits still in the possession of ratings at present serving in the above-mentioned areas are, at the first opportunity, to be suitably packed, labelled and forwarded to *Moreton* at Service expense. The procedure outlined in the preceding paragraph is to be followed in all instances and, in addition, a list of the contents is to be enclosed in each package.

6. Arrangements should be made for the bedding of ratings who travel by air to be forwarded by surface transport as soon as possible, if air freight is not available; ratings travelling by air should be advised to take a pullover.

7. Navy Orders 521 and 576 of 1943 are hereby cancelled.

Schedule No. 1 (Darwin and Thursday Island).

- | | |
|------------------------------|--|
| 1 No. Bag, kit | *2 No. Lanyards |
| 1 No. Bed | 1 No. Lashing, hammock |
| 1 No. Blanket | 1 No. Lifebelt with cover |
| 1 Pr. Boots, heavy | 1 No. Razor |
| 1 Pr. Boots, light, or shoes | *1 No. Ribbon, cap |
| 1 No. Brush, boot | *1 No. Scarf, black |
| 1 No. Brush, clothes | 2 No. Shirts, khaki, long sleeves |
| 1 No. Brush, hair | 3 No. Shirts, tropical, khaki |
| 1 No. Brush, shaving | 3 Prs. Shorts, tropical, khaki |
| 1 No. Brush, tooth | 2 Prs. Socks, black |
| 1 No. Cap | 3 Prs. Stockings, khaki |
| 1 Set Clews and lanyards | 1 No. Suit, blue overall (for engine-room ratings) |
| 1 No. Coat, waterproof | 2 Prs. Trousers, khaki |
| *1 No. Collar, blue jean | *1 Pr. Trousers, serge, fall |
| 1 No. Comb | 2 No. Towels |
| 2 No. Covers, bed | 1 No. Type |
| 2 No. Covers, cap | 1 No. Anti-gas respirator, tool (for artisan and specialist ratings) |
| *1 No. Flannel | |
| 2 No. Hammocks | |
| 1 No. Housewife | |
| *1 No. Jumper, serge | |

* Delete items so marked for men not dressed as seamen and add the following, viz.:-

- 1 No. Badge, Cap
- 3 No. Collars
- 2 No. Shirts, white
- 1 No. Tie, black.

Schedule No. 2 (New Guinea and Other Forward Areas)

- | | |
|---|--------------------------------------|
| 1 No. Bag, kit | 2 No. Covers, bed |
| 1 No. Bed | 2 No. Covers, cap |
| 1 No. Belt | 2 No. Hammocks |
| 1 No. Blanket | 1 No. Housewife |
| 1 Pr. Boots, heavy | 1 No. Lashing, hammock |
| 1 No. Brush, boot | 1 No. Lifebelt with cover |
| 1 No. Brush, clothes | 3 No. Shirts, khaki, long sleeves |
| 1 No. Brush, hair | 1 Pr. Shoes, black |
| 1 No. Brush, shaving | 2 Prs. Socks, black |
| 1 No. Brush, tooth | 4 Prs. Socks, thick (Army pattern) |
| 1 No. Cap | 1 No. Suit, blue overall (one piece) |
| 1 No. Cap ribbon or cap badge | 3 No. Towels |
| 1 Set Clews and lanyards | 3 Prs. Trousers, khaki |
| 1 No. Coat, oilskin (thin tropical Army type or ground sheet-cape). | 1 No. Type |

and in addition:-

- 1 No. Anti-gas respirator
- 1 Bottle mosquito repellent lotion
- 12 No. Tablets, Atebrin
- Tool kit (for artisan and specialist ratings).

(516/201/595.)

(This Order will be reprinted for posting on Notice Boards.)

264.

ISSUE OF MESS GEAR AND BLANKETS TO PERSONNEL TRAVELLING.

With reference to paragraph 4 of Navy Order 170 of 1944, the cash value of any mess gear and blankets issued on loan to personnel travelling between Melbourne, Sydney and Brisbane and subsequently lost by neglect is, if practicable, to be recovered from the personnel responsible by the Railway Transport Officer to whom, and at the time, the draft reports on completion of the journey. Where responsibility for loss of mess gear cannot be directly attributed to any particular member of the draft, the total value of the articles lost is to be apportioned equally amongst all personnel concerned and recovery effected direct from each person.

2. The Railway Transport Officer is to issue an official receipt for all amounts collected by him. Where an amount represents value of deficient mess gear apportioned amongst a number, the receipt is to be issued to the member in charge of the draft.

3. All moneys so collected are to be paid over by the Railway Transport Officer on the day of receipt or at the first opportunity subsequently, to the Accountant Officer of the nearest Naval Establishment, accompanied by a list showing details of the articles lost, their value and, in the case of deficient mess gear, the total number of persons from whom value has been recovered.

4. The Railway Transport Officers at Melbourne and Brisbane are to forward for the information of the Railway Transport Officer, Sydney, a copy of any similar list relating to recoveries at their centres.

(530/201/531.)

265.

FOOD RATIONING AND FOOD ECONOMY—GENERAL INSTRUCTIONS.

The following details concerning the present application of food rationing in Naval messes are promulgated for information and guidance. These instructions include the substance of Navy Orders 119 of 1942, 245 and 594 of 1943, C.O.R., Article 430, also various previous signals on this subject—all of which are hereby cancelled—and incorporate certain new matter.

2. It is desired to impress upon all Naval personnel, and particularly upon those responsible for the drawing up of menus and the preparation and issue of meals, the great importance of exercising strict economy in the expenditure of all foodstuffs and the avoidance of waste.

3. In respect of canned foods, such issues should, as far as is possible, be avoided in ships where suitable fresh provisions are procurable as a regular or alternative issue. In shore establishments, the use of canned foodstuffs, such as meats of all descriptions, fish, fruit, milk and vegetables, is normally to be restricted to emergency requirements. In this connexion, dried fruits and vegetables are, as a general rule, to be used in shore establishments when fresh articles are not in season; and a similar procedure should also be observed in ships, as far as can be conveniently arranged, in order that stocks of canned provisions may be conserved for the emergent purposes for which they are normally supplied.

4. In no circumstances are letters on questions arising from these instructions to be addressed to the Rationing Commission or other food authority. Any such problems are to be submitted to the Naval Board through the usual Service channels.

A—SURRENDER OF CIVILIAN RATION DOCUMENTS BY NEW ENTRIES.

All persons (male and female) joining the R.A.N. are to surrender their civilian ration books at the Naval establishment or base at which they are entered, and such documents are to be disposed of as provided in paragraphs 30 to 33 of Navy Order 480 of 1943.

B—PERSONNEL VICTUALLED FROM SERVICE SOURCES OR ACCOMMODATED AND MESSED IN NAVAL MESSSES IN ACCORDANCE WITH NAVAL BOARD AUTHORITY.

The consumption of the commodities set out below is to be restricted to the quantities shown, or as otherwise stated. The quantities indicated are maxima, and lower average consumption should be aimed at, particularly in shore establishments and the larger ships, when this is possible consistent with a satisfactory standard of victualling.

(i) *Meat* (see (b) below).

	Quantity per head weekly.
Carcass meat	6 lb.
Without bone	4½ lb.

For women, three-fifths of the above quantities only are to apply, and for the purpose of the authorized weekly allowance the following procedure is to be observed:—

(a) When bone-out meat is issued in small ships in accordance with Navy Order 671 of 1943, also when special parts of carcass meat such as rolled ribs, top side, thick flank, corned rounds, &c., are issued in all ships and establishments, one-third of the net weight is to be added to convert the total quantity to the equivalent of carcass meat in the weekly abstract of issues referred to in paragraph (f) below.

(b) Issues of small goods, such as sausages, sausage meat, tripe, liver and kidneys, also poultry (on customary special occasions) and rabbits, all of which are not rationed meats to the civilian population, are not to be included in the total weekly meat allowance.

- (c) Where one or more butcher ratings are allowed by complement, mutton, veal, lamb and pork are to be obtained only in complete carcasses except in the case of mutton or pork chops.
- (d) In addition to the weekly allowance referred to in (i) above, preserved beef and preserved mutton may be issued in sea-going ships, also in Shore Depots North of latitude 20 degrees South, up to 6 oz. per head weekly; but issues in excess of that quantity (except authorized Extra Issues) must be converted and charged against the total weekly allowance on the basis of 1 lb. of carcass meat for each 10 oz. of preserved meat.
- (e) To enable a satisfactory check to be maintained on consumption, the full requirements of all descriptions of meat rationed to the public are on all occasions to be obtained from Service stocks by Officers' messes and other repayment messes.
- (f) Issues of rationed foodstuffs are to be summarized weekly in accordance with the appended *pro forma* statement, and such statement is to be attached to the relevant weekly section of A.S.71B or A.S.462Z, as applicable.

(Pro Forma Statement.)

H.M.A.S. *Lonsdale*.

Week ended 26th February, 1944.

WEEKLY ISSUES OF RATIONED MEAT AND OTHER RATIONED FOODSTUFFS.

	<i>Meat.</i>	
	General Mess.	Repayment Messes.
(a) Total numbers victualled for this week ..	5,250 Males 770 Females	560
(b) Average daily number victualled during this week	750 Males 110 Females	80
(c) Maximum weekly allowance of carcass meat—		480 lb.
750 at 6 lb.	4,500 lb.	
110 at 3 3/5 lb.	396 ..	
Total	4,896 ..	480 ..
(d) Meat without bone issued	1,200 ..	225 ..
Add 1/3 to convert to carcass meat	400 ..	75 ..
(e) Carcass meat issued	2,550 ..	144 ..
(f) Preserved meat issued	50 ..	10 ..
Plus 3/5 to convert to carcass meat	30 ..	6 ..
Total	4,230 ..	460 ..

Other Rationed Foodstuffs.

	Maximum Weekly Issue.	Total Issues for this Week.		Quantity in Ounces (to 2 Decimal Points) per Head for this Week Calculated on Numbers in (b) Above.	
		General Messes.	Repayment Messes.	General Messes.	Repayment Messes.
	oz.	lb.	lb.	oz.	oz.
Butter	12½	620	60	11.53	12.00
Tea	2½	136	13	2.53	2.60
Bacon	10½	304	40	5.65	8.00
Cheese	8	214	24	3.98	4.80

NOTE.—Allowance for casual meals supplied from officers' messes and general messes (in the latter only where authorized by the Naval Board) may, if desired, be claimed in accordance with D (ii) below.

(ii) *Butter.*

Issues to general mess and to repayment messes are not to exceed a weekly total of 12½ oz. per head, representing 1¾ oz. per diem for each officer or rating victualled.

(iii) *Tea, Coffee and Chocolate.*

The issue of tea to general messes and repayment messes is not to exceed the following quantities:—

In Sea-going Ships—½ oz. per diem for each officer or rating victualled.

In Shore Naval Establishments—¾ oz. per diem for each officer or rating victualled.

Coffee may be issued in lieu of tea in the proportion of 1 oz. of coffee to ½ oz. tea.

Chocolate is to be restricted to quantities actually required for authorized extra issues and the normal early morning issue.

(iv) *Rice and Pepper.*

All possible economy should be exercised in the consumption of these two commodities which are in short supply.

(v) *Bacon and Cheese.*

The maximum weekly issue of these items is not to exceed the following:—

Bacon (including ham) ..	10½ oz. per head.
Cheese	8 oz. per head.

(vi) *Potatoes.*

Owing to heavy demands for the armed forces, including dehydrated supplies for consumption in forward areas and for despatch abroad, this item is periodically in short supply, and all possible economy in consumption should be exercised consistent with the maintenance of a reasonable, but reduced where practicable, average daily issue per head.

C—NAVAL PERSONNEL IN RECEIPT OF PROVISION OR LEAVE ALLOWANCE.

Except in special cases approved by the Naval Board, it is not permitted that provisions be issued from Service stocks—*vide* C.O.R., Article 422, clause 7, in this connexion. Personnel in this category are issued with special Food Ration Coupons as provided in the immediately following Navy Order containing food coupon instructions.

D—MISCELLANEOUS.

(i) *Landing of Foodstuffs.*

It is strictly forbidden for all foodstuffs of Service origin, whether rationed or not, to be landed at any time for private purposes.

(ii) *Casual Meals Supplied from Officers' Messes.*

In Officers' messes of shore establishments a record is to be kept of casual meals customarily provided to Officers not borne for victualing. Up to one-third of the daily allowance, or one twenty-first of the weekly allowance, of rationed articles may be claimed and included in the weekly statement referred to in B, (i), (f), above in respect of each casual meal so served.

(iii) *Supervision of Issues.*

The Accountant Officer (or Commanding Officer where no Accountant Officer is borne) is to take steps to ensure that issues to the general mess and on repayment are limited, or otherwise controlled as provided herein, and that the weekly abstract of issues of rationed foodstuffs is regularly inspected and initialled to ensure that the total issues to each mess weekly do not exceed the maximum quantities authorized.

(350/201/85.)

266.

FOOD COUPONS—NAVAL PERSONNEL.

New Rationing Year—1944-1945.

The Rationing Commission has decided that the 1944-1945 rationing year will commence on Monday, 5th June, 1944, upon which date a new type of Service Food Ration Coupon Sheet will be brought into operation, each individual food coupon sheet for a half week containing the following:—

Tea—	one half coupon,
Sugar—	one quarter coupon,
Butter—	one half coupon,
Meat—	two half coupons,

and the quantitative value of each being one-half of the corresponding civilian coupon.

2. The Service Food Ration Sheets will be common to the Navy, Army and Air Services, including Royal Australian Naval Nursing Service and Women's Royal Australian Naval Service. Coupons will be negotiable whenever presented and not limited for use over a period as in the case of civilian coupons.

3. "Special" Ration Coupon Sheets for tea, sugar and butter, and ration coupons for meat, for the rationing year expiring on Sunday, 4th June, 1944, will continue to be negotiable up to and including 31st July, but no issues of such coupon sheets or coupons are to be made after Saturday, 3rd June. Bulk stocks of 1943-1944 coupons in the possession of issuing authorities on that day are to be returned to the Naval Officer-in-Charge at the most convenient capital city area for transmission to the Deputy Director of Rationing; unissued stocks at Darwin, Flinders Naval Depot and H.M.A.S. *Lonsdale* are, however, to be returned to the Director of Victualling.

4. *Entitlement to Food Ration Coupons.*—Specially printed sheets representing a "half week" entitlement of rationed food commodities will be issuable to the following personnel:—

- (a) Personnel proceeding on leave.
- (b) Personnel in receipt of provision allowance or victualling allowance and not specially permitted to purchase from Service stocks of provisions.
- (c) Personnel on consolidated rates of pay, other than Naval Dockyard Police who retain their Civilian Ration Books.

5. For leave purposes coupons are to be issued to each person on the following scale:—

<i>Period of Leave.</i>	<i>Coupon Entitlement.</i>
1 to 3 days	.. 1 sheet of combined coupons.
4 to 7 days	.. 2 sheets of combined coupons.
6 to 10 days	.. 3 sheets of combined coupons.
11 to 14 days	.. 4 sheets of combined coupons.
15 to 17 days	.. 5 sheets of combined coupons.
18 to 21 days	.. 6 sheets of combined coupons.

and so on, but in no case are coupons to be issued at any one time for a period exceeding 28 days.

As the surrender of food coupons is not required for meals at a hostel, hotel, or other residential establishment, if period of stay is less than six days in any one fortnight, personnel are to be informed, when such accommodation is anticipated, that coupon issue is not to be applied for in such circumstances.

6. In addition to the personnel referred to in paragraph 4, issue may be made to officers and men of sea-going ships who are granted "short" leave to visit their "homes," as defined in Naval Financial Regulations and Instructions, Article 170. Entitlement is one "half-week" coupon sheet for each half week to such personnel as are granted regular short leave. "Home" may be interpreted, at the discretion of the Commanding Officer, as including the home of a near relative (e.g., parent, sister, or brother). This special concession applies to sea-going vessels only. Entitlement does not extend to Auxiliary Mine Sweeping Vessels, Boom Ships, Channel Patrol Craft, &c., which are in regular touch with their administrative base.

7. *Requisitioning of Coupon Supplies.*—Sheets, each containing twenty (20) "half-week" combined coupons, are to be requisitioned from the State Deputy Director of Rationing by Naval Officers-in-Charge at Sydney, Brisbane, Fremantle, Port Adelaide and Hobart,

for issue to H.M.A. Ships and Establishments and to other Naval authorities within or adjacent to their districts. Naval Officers-in-Charge, Flinders Naval Depot and Port Melbourne, are to requisition upon the Director of Victualling. Naval Officer-in-Charge, Darwin, will be supplied without requisition by the Director of Victualling.

Sea-going ships are to obtain requirements from the most convenient of the authorities referred to. Requirements of Tenders, Port War Signal Stations, &c., are to be arranged by Parent Ships or Base Depots. Personnel returning on leave from outlying stations where stocks of coupon sheets are not held are to be instructed to report to the Naval authority at their port of destination for coupon issue.

8. *Custody of Coupons, Accounting, and Returns.*—All stocks are to be held in the custody of a responsible officer, and coupons are only to be issued to individuals on the authority of the Commanding Officer who is responsible that a suitable record is maintained of all receipts and issues, and that every precaution is taken to avoid abuses or unauthorized issues.

The following returns are to be rendered to the Director of Victualling at the end of each calendar month:—

- (a) By Naval Officers-in-Charge, indicating—
 - (i) Number of coupons received.
 - (ii) Number of coupons issued.
 - (iii) Ships, other than Tenders, supplied.
 - (iv) Number of coupons remaining in hand.
- (b) By Commanding Officers of Establishments and Sea-going Ships, indicating—
 - (i) Number of coupons received during the month, and sources of supply.
 - (ii) Number of coupons issued.
 - (iii) Number of coupons remaining.

Issues to Allied Vessels and Establishments are to be separately shown.

9. This Order is to come into operation on Monday, 5th June, 1944, upon which date Navy Orders Nos. 263 and 392 of 1943 are cancelled.

(350/201/85.)

(This Order will be reprinted for posting on Notice Boards.)

267.

SALVAGE OF CONDEMNED, UNSERVICEABLE, ETC., STORES.

Army Salvage Service.

A branch of the Department of the Army, called the Army Salvage Service, exists for the purpose of recovery and disposal of condemned, unserviceable and other articles for which no use can be found by the Defence Forces. A Salvage Control Officer has been appointed to each Army Command or Lines of Communication Headquarters.

2. The Salvage Control Officer is responsible that the most efficient use is made of apparently waste materials. He is charged, in conjunction with the Services and Departments concerned, with the inspection of accumulated obsolete stores, and of material which has been returned as unsuitable for further use, in order to assist in its economical disposal.

3. He arranges, through the District Contracts Board, for the purchase or disposal of salvage articles or substances.

4. He also advises regarding allocation of proceeds of realizations on food recovery disposals in due proportion to amounts collected from each establishment.

General Description of Articles and Substances to be Handled as Salvage at Naval Establishments—Method of Collection and Handling.

5. The following items are those which, with due regard to circumstances (i.e., locality of Establishment), should be saved and put to further use either by transfer to the Army Salvage Service or otherwise:—

Fats from galley, fats from fat traps; cooked bones, green bones; waste paper of all descriptions; all classes of metals; rags and bags; rope and string; tobacco and cigarette tins; linings from tea chests; steel bands from bales and wires from packing cases; old nails; empty toothpaste tubes; bottles; broken glass; ashes from galley; meat and fat trimmings from meat; disused and broken cases; palliasse straw; rubber arisings; electric cable arisings; workshop turnings, punchings, scrap timber; and scrap generally.

6. One of the first places in any Establishment which calls for strict supervision is the galley, where waste attributable to many causes may be traced. Fats and bones should not be classed as refuse in the generally accepted interpretation of the term, but regarded as "by-products." The desirability of efficient rendering down of all meat and bone refuse for tallow, prior to its reaching the garbage receptacle, cannot be overestimated. No fats should be discarded which otherwise can be saved, and the same applies to cooked bones. Where practicable, sufficient receptacles should be utilized to permit the following segregation:—Wet garbage, dry garbage, ashes, tea leaves, green scraps, cooked bones, potato peelings. Close liaison in relation to kitchen refuse should be maintained by Establishments with the Army Salvage Officer.

7. Waste paper, such as newsprint, office waste, paper from packing cases, or any other such class should be collected and tied into bundles until a sufficient quantity is ready for disposal. This commodity is indispensable to our everyday social, industrial and military existence, and organized collection must be adopted for its recovery after use. Confidential waste, or any of a nature which renders it desirable that it should not fall into the hands of private persons, is to be conserved and pulped under proper supervision, if practicable.

8. Oil from crankcase drainings can now be re-refined for further use. The prime factor in the success of this salvage operation is care in collection to ensure that no foreign matter, water, or other types of oil are allowed to enter the containers provided for the purpose of collection.

9. Steel wire and bands from bales and cases, old nails and every other class of metal is of great national value. Steel wire and bands should be coiled into hanks about a foot long and tied in bundles; old nails collected and put into any kind of tin. Unserviceable steel wire rope should be turned over without cutting. In Boom Depots, however,

all unserviceable Rope Unit Wire, 3 inches and 1½ inch, being of a confidential nature, should be cut into suitable lengths and stranded before turning over.

10. Empty bottles of all descriptions, except those which are returnable under contract, must be accounted for, whilst broken glass should be placed in receptacles provided for the purpose. Bottles returnable under contract should be set aside from the ordinary collection.

11. Because of a serious shortage of jute goods in this country, it has become necessary to ensure that present supplies of sacks, bags, cornsacks, &c., be conserved to the utmost. Steps must be taken by all Establishments to see that nothing of this nature is destroyed or put into improper use. Sacks or bags apparently unfit for service should be returned to Army Salvage Service, for the purpose of repair and re-issue or return to industry. The following instructions are to be strictly observed:—

- (a) All surplus empty sacks and bags arising at Establishments should be handed over to the appropriate Army Salvage Unit.
- (b) All empty damaged sacks and bags should be regarded as the property of the Army Salvage Service.
- (c) Under no circumstances must sacks or bags, other than fertilizer bags and those made expressly for the purpose, be used as sandbags; neither must they be used for camouflage purposes.
- (d) Empty sacks and bags (damaged or otherwise) held in Establishments and surplus to local requirements for use as containers should be transferred to Base H.Q. Salvage Depots for re-issue to the Services or to industry as may be required.

12. Oily rags and cotton waste should be kept in separate receptacles and care taken that no extraneous matter is included. No dangerous accumulations of large quantities of inflammable materials should be permitted. At Naval Armament Depots, safe storage is to be provided well clear of the magazine area and accumulations cleared at very frequent intervals.

Useless and not Acceptable to Army Salvage Service—Destroy.

13. Some use for practically all unserviceable items, irrespective of condition, can be found by the Army Salvage Service, and before an item is destroyed, it should be established that it is not acceptable to the Salvage Depot. As a general rule, destruction should be limited to items in respect of which such disposal is essential, e.g., stores of a nature which necessitates immediate action in order to avoid fire risk, infected articles, &c.

Prompt Transfer to the Army Salvage Service Desirable.

14. Periodical survey should be held frequently and regularly as a regular flow of material is preferable from the point of view of its handling by the Army Salvage Service. Nevertheless, special action should be taken to survey stores no longer likely to be required for Naval purposes, with a view to their immediate transfer to the Army Salvage Service where circumstances warrant it.

15. Transfers of stores, including Naval armament stores returned to Naval Armament Depots, should be made to the Army Salvage Service in anticipation of Naval Board approval subject to—

- (a) The stores being surveyed in the usual manner.
 (b) Consideration being given in each case, before transfer is proposed, whether return of the stores to Store Depots is economical or desirable in view of the nature of the items involved and the possibility of reconditioning the stores for further Naval use.
 (c) Reports of Survey being forwarded for covering Naval Board approval as each transfer is effected.

Re-utilization of Salvaged Materials held in Salvage Depots.

16. The difficult position of supply in regard to many technical items of war equipment and stores, including motor transport parts, is such that the re-use of salvaged stocks is essential wherever possible. Attention is drawn to the desirability of making frequent inspections of stocks in Salvage Depots when necessary and practicable. Such inspections should be made by appropriate officers to ascertain what items are available for local use, thus reducing demands for new issues.

Receipt for Stores Transferred.

17. A proper acquittance should be obtained to support the entry in the Stores Accounts for all issues of articles and materials to the Army Salvage Service. A receipt by a responsible officer of the Army Salvage Service is necessary, that given by a driver of an Army vehicle not being sufficient.

H.M.A. Ships.

18. The above instructions apply to H.M.A. Ships as far as practicable. Action should be taken, in conjunction with the Naval Officer-in-Charge or Store Officer, to land any items which have a salvage value.

19. Naval Armament Stores in Ships and Bases are to be dealt with in accordance with existing instructions, but attention is drawn to the necessity for prompt return of arisings after firings, e.g., cartridge cases, fuse-hole plugs, empty primers, shell grummetts and ammunition packages.

(612/238/1280.)

268.

BOOKS AND FORMS.

The under-mentioned publications have been distributed:—

- B.R.268 (38) (Late C.B.1945 (10)).—Handbook on 36-in. Mark VIS Searchlight Lamps.
 B.R.268 (39) (Late C.B.1945 (16)).—Electrical Manual, Volume II, Mark VII Searchlight Lamps.
 B.R.268 (40) (Late C.B.1945 (17)).—Electrical Manual, Volume II, 20 and 24 inch Mark IV Searchlight Lamps, 1942.

(A.F.O. 6169/43.)
 (571/202/1913.)

B.R.695.—List of International Telegraph Offices—Annexe Nos. 37, 38, 39, 41 and 42.

(A.F.O's. 3760 and 4882/43.)
 (571/202/1814.)

B.R.909 (Late C.B.1877).—Instructions for Analysing Gunnery Practices, 1931.

(A.F.O. 4640/43.)
 (571/202/1907.)

B.R.912 Series (Late C.B.1925 Series).—Director Handbook:—

- B.R.912 (1).—General Information.
 B.R.912 (1) (A).—General Information—Addendum No. 1.
 B.R.912 (2) (40).—Gyro Sights.
 B.R.912 (3).—General Information containing Battle Ships and Cruisers only.
 B.R.912 (4).—Instruments common to *Nelson, Kent, London* Classes.
 B.R.912 (5).—Instruments fitted in *Nelson* Class only.
 B.R.912 (6).—Instruments fitted in *Kent* and *London* Classes only.
 B.R.912 (6) (1).—Addendum No. 1 to B.R.912 (6).
 B.R.912 (7).—Instruments fitted in *Norfolk, Dorsetshire, York* and *Exeter*.
 B.R.912 (7) (1).—Addendum No. 1 to B.R.912 (7).
 B.R.912 (8).—Instruments fitted in *Leander* and *Neptune* Class.
 B.R.912 (9) (40).—Gyro Sights Types "H" and "J" and Electromagnetic Sights "HM".
 B.R.912 (10).—Adventure Type Director.
 B.R.912 (11).—Instruments fitted in *Ajax, Amphion, Arethusa, Apollo, Sydney*.
 B.R.912 (11) (1).—Addendum No. 1 to B.R.912 (11).
 B.R.912 (12).—Instruments fitted in "C" and later Classes of Flotilla Leaders and Destroyers.
 B.R.912 (13).—Time Interval Compensation Gear.
 B.R.912 (14).—"P" Sight, 1940.
 B.R.912 (15).—Fire Control Box Marks IV and IV*.
 B.R.912 (16).—Cross Levelling Gear for Low Angle Fire.

(A.F.O. 4640/43.)
 (571/202/1909.)

B.R.914 (Late C.B.1953 (40)).—Handbook on the Fuse Setting Machine, 1940.

(A.F.O. 4640/43.)
 (571/202/1894.)

B.R.915 (Late C.B.4108).—Handbook for 5.25-in. Q.F. Mark I Gun on H.A. L.A. Turn Marks I and II Markings.

(A.F.O. 4640/43.)
 (571/202/1895.)

B.R.919 Series (Late C.B.4056 Series).—Handbook of the High Angle Control System:—

- B.R.919.—Guard Book and Index for Pamphlets on the High Control System, Mks. I-IV and Associated Equipment, 1940.
 B.R.919 (A).—Handbook on the High Angle System—General, 1940

- B.R.919 (B).—Handbook on A.B.C. Gear as fitted to H.A.C.S. Mark III, 1941.
 B.R.919 (C).—Handbook on Magslip Gear as fitted to H.A.C.S. 1940.
 B.R.919 (D).—Handbook on Gyro Roll Correctors, 1940.
 B.R.919 (E).—Handbook on Cross Levelling and Roll Stabilizing Gear, 1941.
 B.R.919 (F).—Handbook on Gyro Rate Unit Mark II* and Gyro Rate Unit Box, 1941.
 B.R.919 (1).—Handbook on H.A.C.S. I*** and I***C, 1942.
 B.R.919 (2).—Handbook on Differences between H.A.C.S. II*** and H.A.C.S. 1, 1942.
 B.R.919 (3).—Handbook on H.A.C.S. III and IIIC, 1941.
 B.R.919 (4).—Handbook on H.A.C.S. IV and IV*, 1940.
 B.R.919 (5).—Handbook on H.A. L.A. Director, Marks V and V*, 1941.

(A.F.O. 4640/43.)
 (571/202/1910.)

- B.R.925 (Late C.B.4146).—3-in. U.P. Harvey Projector—Instructions for D.E.M.S.

(A.F.O. 4640/43.)
 (571/202/1905.)

- B.R.927 (Late C.B.3089).—Instructions for use of B.E. Smoke Shell, 1942.

(A.F.O. 4640/43.)
 (571/202/1906.)

- B.R.993 (Late C.B.4194).—Handbook of Mark XXI Sinker.

(A.F.O. 5919/43.)
 (571/202/1914.)

- B.R.994 (Late C.B.4259).—Handbook of the Mark XXVII Mine, 1942.

(A.F.O. 5919/43.)
 (571/202/1915.)

- B.R.995 (Late C.B.4275).—Pamphlet on the Mark XXV Mine, 1943.

(A.F.O. 5919/43.)
 (571/202/1912.)

- O.U.5353.—August-September Supplements, British Merchant Ships Lost.

- O.U.6353A.—August-September Supplements, Foreign Merchant Ships Lost and Damaged by the Enemy.

(A.F.O. 5422/43.)
 (571/203/2460.)

- Training Manual Civil Defence No. 4, 1st Edition—Incident Control.

(571/201/4127.)

- Aircraft Recognition Journal, Volume II, No. 4.

(415/201/1879.)

By Authority: H. E. DAW, Government Printer, Melbourne.

RESTRICTED.

(FOR OFFICIAL USE ONLY.)

Commonwealth Navy Order.

Navy Office, Melbourne,

6th June, 1944.

The following Order, having been approved, is hereby promulgated for information and guidance, and necessary action.

By direction of the Naval Board,

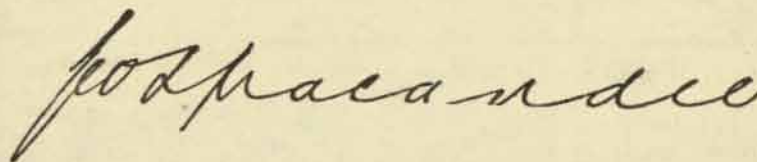

Secretary.

*The Rear-Admiral Commanding H.M.A. Squadron,
 and Commanding Officers of H.M.A. Ships,
 Officers in Charge of H.M.A. Naval
 Establishments, and others concerned.*

TABLE OF CONTENTS.

No.	Subject.
269.	Preservation of Health—General Hygiene and Sanitation—Including the Prevention of Malaria.
C.5728/44.	

269.

PRESERVATION OF HEALTH—GENERAL HYGIENE AND SANITATION—INCLUDING THE PREVENTION OF MALARIA.

Most diseases in tropical areas are transmitted by mosquitoes, flies, and water, and are preventable. Conditions which lead to the breeding or attraction of flies and mosquitoes can be controlled.

2. All Commanding Officers are, therefore, to ensure that officers and ratings receive instructions in the following general rules of hygiene; further, Commanding Officers are to see that the instructions are observed.

CONTROL OF DISEASES TRANSMITTED IN FOOD AND WATER.

A. Protection from Carriers of Bowel Disease.

(1) All personnel suffering from diarrhoea are to report for treatment immediately. Treatment *vide* Appendix "A" of this Order is to be instituted immediately. Any patient not cured within 48 hours and any who are passing blood or mucus are to be sent to hospital as soon as possible.

(2) Personnel who have had typhoid fever or dysentery or who are being treated for diarrhoea are not to be employed handling food until certified free from infection by a medical officer.

(3) K.R. and A.I., Art. 1383, is to be strictly observed.

B. Latrines.

(1) Human excreta must at all times be protected from flies.

(2) Deep trench, if possible at least 10 feet deep, or bored hole latrines are to be used. They must be fitted with a fly-proof superstructure and self-closing lid. A fly trap is to be fitted. Flies trapped are to be burnt daily.

(3) When filled to within 3 feet of the surface, latrines are to be sealed off with oiled soaked canvas, hessian or paper and then covered with earth. The site is to be clearly marked. Latrines must not be sited within 40 yards of any source of water supply.

(4) Latrine seats must be scrubbed daily with antiseptic solution.

C. Reduction of Flies.

(1) All waste matter or refuse which attracts flies and in which they may breed is to be burnt. All organic waste material which on account of its amount or consistency cannot be immediately destroyed by burning is to be sprayed by means of a knapsack sprayer with undiluted creosote.

(2) All tins and cans are to be thoroughly burned and flattened so that they cannot hold water in which mosquitoes may breed.

(3) Dumping of refuse within the immediate vicinity of the camp or establishment is prohibited unless with the written approval of the medical officer. Rubbish dumps which are situated within half a mile of establishments (when removal or bull-dozing is not immediately practicable) must be sprayed with creosote as in (1) or with a mixture of Sodium Arsenite $\frac{1}{2}$ lb., sugar 5 lb., and water 5 gallons (one bucketful).

(4) All sullage water from galleys, showers, ablution benches, etc., is to be passed through a strainer to remove food particles and debris, then through a grease trap and finally run underground into a soakage pit in such a way that natural water courses are not polluted. Soakage pits should not be steeply graded but should conform to the contours of the terrain. They should be dug in the absorbent upper layer of soil, the dimensions being 4 ft. x 4 ft. x 4 ft., filled up to within 6 inches of the surface with stones and perforated burnt-out tins, then covered with brushwood or sacking over which earth is to be spread.

(5) Flies are to be destroyed in messes, galleys, etc., by fly traps, poisoned baits and swatting.

D. Prevention of Contamination of Food.

(1) All food is to be specially cared for and supervision is to be exercised by the Medical Officer to determine its suitability for human consumption, *vide* K.R. and A.I., Article 1392 (2).

(2) Food at all times is to be protected from dust, dirt, flies and other pests, especially during transport, storage and whilst on mess tables.

(3) Food safes, preparation and storage rooms, galleys and mess rooms are to be screened with fly wire as soon as possible in that order of priority.

(4) Personnel are to be specially instructed in the necessity for cleanliness in the care and maintenance of their mess gear. Mess gear and cooking utensils are to be boiled after cleansing. Mess gear is to be protected from dust, flies, etc., between meals.

E. Provision of Safe Water.

(1) The provision of an adequate and safe water supply is of first importance in the maintenance of health. It is, therefore, the duty of all Commanding Officers to ensure that adequate precautions are taken that water is fit for consumption. They are to seek the advice of Medical Officers or personnel trained in hygiene on this subject.

(2) All water for Naval parties or Bases is to be sterilized by super-chlorination and dechlorination by special water duty men under the direction of the Medical Officer.

(3) When water cannot be sterilized in bulk on account of the type of operation, then sterilizing outfits for use with water bottles are to be issued and used. The supervision of sterilization outfits is to be the responsibility of a senior rating nominated by the Commanding Officer of the Base or Naval party.

F. Disinfectants.

(1) Burning is to be the standard method of disinfection of all waste material.

(2) Chemical disinfectants are in short supply and they must be used sparingly. They must be used in accordance with the following rules:—

- (a) Never use a disinfectant undiluted unless so directed in this Order.
- (b) Never dilute more of the disinfectant than is actually necessary.
- (c) Carefully seal the container to retain the strength of the material.

(3) Chlorine disinfectants (Chloride of lime, Chlorosene, etc.) are the standard disinfectants for routine use. They are to be used in the strength of 1 teaspoonful to the pint (equals 1 oz. to a gallon) or 4 oz. tin to a kerosene-tinful of water.

(4) Coal Tar disinfectants (phenyle, izal, cyllin) should not be used except for special purposes, e.g., human excreta or soil polluted with decaying matter.

G. Control of Malaria (Navy Order 603 of 1943 applies).

The Commanding Officer is responsible for mosquito and malarial control in his particular Base or Naval party.

H. Protection from Carriers of Malaria.

(1) Whenever the military situation permits, camp sites are to be approved by a Medical Officer. Camps are not to be situated within half a mile of native camps or villages.

(2) All febrile cases in detached parties are to be kept under mosquito nets until a diagnosis of malaria or dengue is excluded. All cases of suspected malaria or dengue are to be hospitalized.

I. Personal Protection Against Malaria.

(1) Whenever possible, mosquito nets are to be used by all personnel throughout the night. Nets are to be kept in good repair and completely tucked in under the bedding in such a manner that no part of the body touches the net.

(2) The instructions for protective clothing given in Navy Order 231 of 1944 are to be strictly observed.

(3) Between sunset and sunrise while not under a mosquito net, personnel are to apply repellent lotion to the exposed parts of the body at 3-hourly intervals commencing at sunset.

(4) No swimming and bathing outside mosquito-screened bathrooms or shower houses is to be permitted between sunset and sunrise.

(5) The Commanding Officer is to detail an officer or senior rating who is to ensure that suppressive atabrin is taken in the following dosage:—

- (a) In highly malarious areas, the dosage of atabrin is one tablet (0.1 gm.) seven days of each week.
- (b) In malarious areas, other than those designated as highly malarious, the dosage is one tablet (0.1 gm.) on Monday, Wednesday and Friday of each week.

(See also Navy Order 603 of 1943 as amended by Navy Order 240 of 1944):—

J. Prevention of Mosquito Breeding.

(1) Each Naval party is responsible for the prevention of mosquito breeding in its immediate area.

(2) Hygiene units are to be supervised by the Medical Officer or Hygiene Officer.

(3) All slit trenches are to be filled in unless adequately drained or unless completely emptied of water weekly.

(4) All small depressions in the area where water may remain for more than one week are to be filled in; this applies particularly to wheel ruts.

(5) The Commanding Officer of Naval parties in areas where large collections of water present major mosquito control problems is to consult the Medical Services as to the most effective measures to be adopted.

(6) If for some unavoidable reason small collections of water still remain within the area of control, they are to be sprayed with malaria oil once per week.

(7) If mosquitoes are found breeding in artificial containers (tins, cans, oil drums, tanks, etc., used for storage), these containers are to be screened or effectively covered to exclude mosquitoes, emptied or treated with malaria oil or lead-free petrol.

(8) All existing drainage schemes within the area are to be maintained.

(9) Frequent thorough examination of the area is to be made, particularly during the wet season to implement the above.

(10) Before leaving the area, all Naval parties are to ensure that all trenches, latrines, or any other excavations that may hold water are filled in or drained.

K. Measures to Destroy Adult Mosquitoes.

(1) All tents, huts and slit trenches are to be sprayed with mosquito spray between 1800 and 2200 hours.

(2) The frequency of spraying in any area is to be laid down by local orders as recommended by the senior Administrative Medical Officer of the area.

(3) Sixty strokes with the hand sprayer are sufficient for a compartment of 10 ft. x 10 ft. x 10 ft., and where possible the space is to be closed for 20 minutes after spraying.

L. *Training.*

(1) Lectures and practical demonstrations are to be given at frequent intervals in hygiene and malarial control.

APPENDIX "A".

Any case of sudden diarrhoea in Corvettes, Fairmiles, other small ships and establishments in the New Guinea area, not carrying a medical officer, is to be treated with—

Item 781/3. Tab. Oral, Sulphanilylguanidine (Sulphaguanidine). The following routine in sequence is to be adopted:—

- (a) A dose of 16 tablets is to be given as soon as the diarrhoea starts.
- (b) A dose of 8 tablets is to be given every four hours for three days.
- (c) A dose of 8 tablets is to be given three times a day for a further two days.

(2) The doses of tablets are to be well stirred in a glass of water until they are disintegrated before being taken.

(3) When the ship arrives at a port where a medical officer can be consulted, all cases who are on treatment or who have completed treatment should be referred to him for examination, and he will advise as to any further action necessary.

(4) All cases of diarrhoea that do not respond to the above treatment should be sent to the nearest Service Medical Officer for further investigation and treatment.

(527/201/902.)

RESTRICTED.(FOR OFFICIAL USE ONLY.)

Commonwealth Navy Orders.

Navy Office Melbourne,

6th June, 1944.

The following Orders, having been approved, are hereby promulgated for information and guidance, and necessary action.

By direction of the Naval Board,

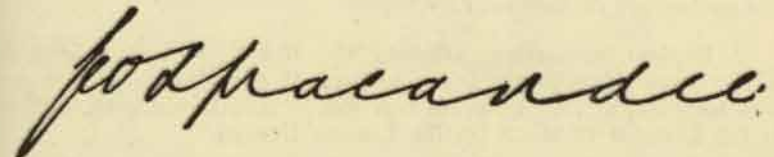

Secretary.

*The Rear-Admiral Commanding H.M.A. Squadron,
and Commanding Officers of H.M.A. Ships,
Officers in Charge of H.M.A. Naval
Establishments, and others concerned.*

TABLE OF CONTENTS.

No.	Subject.
270.	H.M.A. Shore Establishments—Name Ships.
271.	Tropical Scientific Section.
272.	Teleprinter Operators.
273.	W/T Ratings W.R.A.N.S.—Advancement.
274.	Payment of Fares of Relatives Attending Funerals of Deceased Service Personnel.
275.	A.M.S. Vessels—Contamination of Boiler Feed Water with Oil Fuel.
276.	Magazines—Unlocking.
277.	Periodical Examination of Explosives.
278.	Boxes Ammunition C.222 and C.199.
279.	Electric Fans—H.D.M.L.'s.
280.	Wattle Rod Fenders.
281.	Polarised Sun Glasses—Replacement by Pattern 4074 Anti-Glare Spectacles.
282.	Special Clothing Issues for Personnel in Forward Island Areas.
283.	Supply of Canteen Stores.
284.	Convalescent Home for Women's Services.

270.

H.M.A. SHORE ESTABLISHMENTS—NAME SHIPS.

With reference to Navy Order 177 of 1943, H.M.A.S. *Lucy Star* has been renamed H.M.A.S. *Kuranda*.

(404/201/557.)

271.

TROPICAL SCIENTIFIC SECTION.

The Departments of Navy, Army and Air have jointly approved of a Tropical Scientific Section being sponsored by the Scientific Liaison Bureau to function in operational areas. This Section will be attached, as necessary, to Force Headquarters who will be responsible for its administration but will make its services available to the Naval and Air authorities in that area on request.

2. Reports on matters affecting the R.A.N. will be passed direct to the Naval Headquarters in that area of operations. Direct contact with technical and scientific matters will be maintained with the Section by the Director of the Scientific Liaison Bureau.

3. The Section will pay particular attention to matters associated with deterioration of stores and equipment under tropical conditions and its detailed duties are—

- (i) to be responsible for advising the responsible Service authorities on the installation or placing in service of any experimental or trial consignments of material in a non-active operational area, and, where requested, actually undertake such installations.
- (ii) to undertake tests as required by the responsible Service authorities of the application of new or modified procedures, for instance the testing of fungicides for optical munitions to determine their suitability for general use.
- (iii) to follow through tests and submit scientific reports as and when necessary.
- (iv) to report upon the effect of tropical conditions on general Service material especially conditions of unusual deterioration.
- (v) to assist where possible as advisers to ordnance depots, field workshops and store depots in-so-far as prevention of deterioration from tropical effects is concerned.

4. The Section initially comprises a biologist, chemist and a physicist. This composition will be varied to suit particular conditions with scientists in other spheres as necessary. Personnel of the Tropical Scientific Section will be officer status and will wear Military Uniform without badges but will carry a shoulder identification "Scientific Liaison".

5. In addition to the immediate benefits and contributions in efficiency and economy to be obtained from the work of the Tropical Scientific Section, the results of this work can also be applied in other theatres and overseas. For these reasons it is desired that all Sections make the maximum use possible of the services and facilities of the Tropical Scientific Section.

6. Naval Officers-in-Charge desiring to avail themselves of the advice of this Section should apply as stated in paragraph 1.

(589/201/949.)

272.

TELEPRINTER OPERATORS.

With reference to paragraph 3 of Navy Order 258 of 1942, Teleprinter Ratings who fail in an examination for Leading Signaller (T/P) or Yeoman of Signals (T/P) may be re-examined after six months from date of failure.

2. Conditions for the examination of T/P Operators (W.R.A.N.S.) are contained in Navy Order 204 of 1944, paragraphs 1 (c) and 4.

(622/201/979.)

(This Order will be reprinted for posting on Notice Boards.)

273.

W/T RATINGS W.R.A.N.S.—ADVANCEMENT.

Navy Order 470 of 1943 is to be amended by adding after the words "Navy Order 62 of 1942 (as amended)" in paragraph 2 thereof, the words "and, for W/T 1 rates, as laid down in Signal Training Instructions, table 18".

(432/224/667.)

274.

PAYMENT OF FARES OF RELATIVES ATTENDING FUNERALS OF DECEASED SERVICE PERSONNEL.

With reference to Naval Financial Regulations and Instructions, Article 12, clause 6 (b), issue of railway warrants to relatives of deceased personnel, who are desirous of attending the funeral of the late member, is now permissible for journeys not exceeding 650 miles in lieu of the previous restriction of 200 miles. Navy Order 13 of 1943 refers.

2. Arrangements have been made with the Department of Transport whereby, in all cases in which the next of kin of deceased Servicemen present departmental travel vouchers, No. 4 priority will be granted which will ensure travel being obtained.

(632/202/1085.)

275.

A.M.S. VESSELS—CONTAMINATION OF BOILER FEED WATER WITH OIL FUEL.

One A.M.S. vessel has experienced a serious pollution of reserve feed water due to leaky joints in the oil fuel tank heating system.

2. As the oil fuel tank heating system in A.M.S. vessels is not likely to be used in the areas in which these ships are at present operating, a blank flange is to be inserted in the steam heating drain line at the observation drain tank. This blank is to be made with an extended tongue which is to be painted red. A notation is to be made in the Engineer Officer's notebook and the ship's drawings amended accordingly.

3. A permanent electric light fitting is to be placed at or near the observation drain tank gauge glass.

(603/282/912.)

276.

MAGAZINES—UNLOCKING.

With reference to Naval Magazine and Explosives Regulations, Article 81, Magazine and/or R.U. Lockers may remain unlocked in harbour or at sea, when in the opinion of the Commanding Officer, the state of readiness to be maintained renders this desirable.

2. A notation is to be entered in the Key Register section of Magazine Log, whenever Magazines or R.U. Lockers remain unlocked.

3. In cases, however, where non-service personnel are on board, sentries should be placed over unlocked magazines and R.U. Lockers.

(659/203/551.)

277.

PERIODICAL EXAMINATION OF EXPLOSIVES.

Appended for information and action as necessary, is an advance copy of an Admiralty Fleet Order, regarding annual inspection and examination of explosives on board H.M. Ships and at Naval Bases for 1944:—

“The following variations from the routine examination of explosives as laid down in Articles 300 and 301 of Naval Magazine and Explosives Regulations have been approved for the current year.

2. Examination of the complete outfit of explosives (Article 300, N.M.E.R.) will only be undertaken when the outfit is landed, either during refit or for other reasons. The landing of outfits of ships smaller than destroyers and frigates is, however, to be undertaken when due (i.e., 9-12 months from date of supply as authorized in A.F.O. 6241/43.

3. Annual Inspection and proof of a percentage of explosives (Article 301) will only be carried out from H.M. Ships, Naval Bases and Naval Air Stations during 1944 in respect of the following stores:—

- | | | |
|---|---|---|
| (i) Time Combustion Fuses | } | The percentages to be landed of these items, are to be as laid down in Art. 301, N.M.E.R. |
| (ii) All Explosives Stored in Improvised Shelters | | |
| (iii) A.A.D. and U.P. Stores | | |
| (iv) Detonators Filled Fulminate of Mercury | | |
| (v) Detonators Filled A.S.A/C.E. Packed in Banded Containers | | |
| (vi) Torpedo Igniters | | |
| (vii) Cartridges Impulse Torpedo, Filled Powder | | |
| (viii) Bombs Filled Amatol (Other than those filled Amatol 60/40) | } | All to be landed for examination after 12 months on board. |
| (ix) Depth Charges Filled Low Grade Amatol | | |
| (x) Pyrotechnics | | The percentages to be landed, to be as laid down in Art. 301, N.M.E.R. |
| (xi) “R” Mines | | Those that have been held for 6 months are to be landed for a 100 per cent. overhaul and inspection. Others are not to be landed. |

4. The items shown in paragraph 3 are to include any ammunition of kindred types not of British manufacture.

5. Detonation proof of shell will not be required to be carried out in 1944.

6. *It appears that a number of ships did not land in 1943—the percentages required for inspection under Art. 301 N.M.E.R. which applied in toto for 1943, vide C.A.F.O. 469/43, with the sole exception that the landing of Depth Charges under Art. 301 (19) was limited to those which had been on board for 12 months or more. The instructions as in paragraph 3 above, do not apply to landings which were due to be made in 1943. Any ships, therefore, that did not land the authorized percentages in 1943 are to do so as early as practicable in 1944.*”

2. These arrangements are to apply in the Royal Australian Navy.

(471/201/1502.)

278.

BOXES AMMUNITION C.222 AND C.199.

The use of boxes C.199 for packing Q.F.4-in. Mark XVI gun ammunition, which is destined for despatch to A.S.I.S., and northern bases is to be reverted to.

2. Navy Order 76 of 1944 is hereby cancelled.

(421/202/756.)

279.

ELECTRIC FANS—H.D.M.L.'s.

Approval has been given to the addition of the under-mentioned items to the Lists of Special Allowances of Naval Stores for H.D.M.L.'s:—

<i>Description.</i>	<i>Quantity.</i>	<i>Remarks.</i>
Fans, Electric, 24 volt complete with leads and bulkhead fittings	3 No.	Only for H.D.M.L.'s serving in tropical waters:— 1 No. for Galley. 1 No. for Mess Deck. 1 No. for Wireless Office.
Condensers (to act as suppressors on Fans)	3 No.	

2. First supply of the above-mentioned items will be effected without demand by the Superintending Naval Store Officer, Sydney, as early as practicable.

(603/297/253.)

280.

WATTLE ROD FENDERS.

Approval has been given to the addition of the under-mentioned items to the Lists of Special Allowances of Naval Stores for H.M.A. Escort and Small Vessels:—

Wattle Rod Fenders.—3 ft. x 10 inches.—2 No.

2. Supply of the above-mentioned items will be effected on demand by the Superintending Naval Store Officer, Sydney.

(612/201/5479.)

281.

POLARISED SUN GLASSES—REPLACEMENT BY PATTERN 4074 ANTI-GLARE SPECTACLES.

With reference to Navy Orders 30 and 125 of 1944, the Polarised Sun Glasses referred to are urgently required for re-issue for other services. It is important therefore that they be returned to the nearest Naval Store Depot, at the first opportunity after receipt of supplies of the Pattern 4074 Anti-Glare Spectacles.

(612/236/7507.)

282.

SPECIAL CLOTHING ISSUES FOR PERSONNEL IN FORWARD ISLAND AREAS.

With reference to Navy Order 224 of 1944—"Special Clothing Issues for Personnel in forward Island Areas"—for the words "outfitted by Drafting Depots" in paragraph 1 thereof, read "issued in the establishment from which they are drafted".

(434/210/163.)

283.

SUPPLY OF CANTEEN STORES.

With reference to Navy Order 419 of 1942, it is notified that the rate of discount allowed to Naval Officers' Messes on purchases of stores in bulk from the Australian Army Canteens Service has been reduced as from 1st April, 1944, from 7½ per cent. to 5 per cent.

2. In the case of canteens conducted on the ordinary service system a discount of 5 per cent. will be allowed on bulk purchases as from 1st April, and in addition a rebate of 5 per cent. on purchases made during each month will be paid to the Commanding Officer of the ship or establishment for the Ship's Fund.

3. In shore establishments where the canteen is conducted by the Australian Army Canteens Service, a rebate of 5 per cent. on the monthly turnover will be paid to the Commanding Officer for the Ship's Fund.

(427/201/864.)

284.

CONVALESCENT HOME FOR WOMEN'S SERVICES.

The Victorian Division of the Australian Red Cross Society have opened a convalescent home for officers and other ranks of the Women's Services, at "Edgcliffe," Hampton, Victoria. Medical treatment is under the supervision of Captain Ann McLeod, A.A.M.C., who visits daily.

2. Admission of members of the W.R.A.N.S. to this convalescent home can be arranged by the Senior Medical Officer of the establishment concerned by writing or telephoning direct to the Matron, Tel. XW.3291.

(527/201/904.)

RESTRICTED.(FOR OFFICIAL USE ONLY.)

Commonwealth Navy Order.

Navy Office, Melbourne,

13th June, 1944.

The following Orders, having been approved, are hereby promulgated for information and guidance, and necessary action.

By direction of the Naval Board,

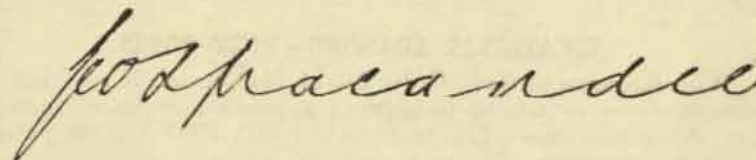

Secretary.

*The Rear-Admiral Commanding H.M.A. Squadron,
and Commanding Officers of H.M.A. Ships,
Officers in Charge of H.M.A. Naval
Establishments, and others concerned.*

TABLE OF CONTENTS.

No.	Subject.
285.	H.M.A.S. "Vigilant"—Re-naming.
286.	H.M.A.S. "Viking"—Re-naming.
287.	Vocational Training—Text Books.
288.	Honours and Awards to R.A.N. Personnel.
289.	Promotion to Warrant Writer and Warrant Supply Officer—Conditions.
290.	R.A.N.R. Petty Officers—Advancement to Chief Petty Officer.
291.	Apprentices—War Service.
292.	Advancement of Ratings Trained in Combined Operations.
293.	Fairmile Rudders.
294.	Failures of Armament Material and Ammunition—Rendering of Forms S.1148 (h), (i) and (j).
295.	Gas Cylinders—Water Pressure Test.
296.	Instructional Films—Disposal of Obsolete and Unserviceable Films.
297.	Supply of Spectacles—Delegation of Authority.
298.	Introduction of Form A.S.155X—Record of Naval Store Ledgerkeepers.
299.	Books and Forms.

285.

H.M.A.S. "VIGILANT"—RE-NAMING.

H.M.A.S. *Vigilant* has been re-named H.M.A.S. *Sleuth*.

(563/201/1419.)

286.

H.M.A.S. "VIKING"—RE-NAMING.

H.M.A.S. *Viking* has been re-named H.M.A.S. *Jurien*.

(404/201/656.)

287.

VOCATIONAL TRAINING—TEXT BOOKS.

With reference to Navy Order 340 of 1943, members studying under correspondence courses or undergoing a planned course of instruction may obtain text books and/or materials authorized for the particular course for which enrolment has been effected.

2. Orders for books, &c., are to be prepared in triplicate in *pro forma* shown hereunder, and consecutively numbered for ready reference. The original and duplicate copies are to be forwarded to the Director of Education and Vocational Training, Navy Office, and the triplicate copy retained in the ship for future reference. The first order for books required for a correspondence course must be forwarded with the application for enrolment.

3. When the application for enrolment is accepted, the original order for books will be forwarded by the Director of Education and Vocational Training to the Services' Book Supply Depot, Public Library, Sydney, for despatch of the books.

4. At time of despatch, a Form of Advice will be sent to the Commanding Officer showing details and cost of the books, &c. On receipt of this advice, the amount involved is to be charged against the pay account of the member in accordance with his authority given on the order, and the Director of Navy Accounts furnished with a reference to recovery for check and payment of claims to be rendered to Navy Office in due course.

It should be specially noted that the only method of payment by the member is through his ledger account.

Where the accounts of the ship in which the advice is received are kept elsewhere, the advice should be forwarded urgently to the Accountant Officer concerned for action.

PRO FORMA OF ORDER.

Ship's Record No.....

VOCATIONAL TRAINING—ORDER FOR BOOKS AND EQUIPMENT.

Course of Instruction.

Title of Book.	Author.	Other Equipment.

To be forwarded to Commanding Officer, H.M.A.S. " " care of G.P.O.

Particulars of Student.

Surname. (Block letters).	Christian Names (in full).	Rank or Rating.	Off. No.	Where Serving.
				H.M.A.S. "

I hereby authorize the amount involved in this order to be charged to my account in Ship's ledger.

(Signature of Applicant).....

Approved—

(Date)..../..../....

Education Officer.

To/

Director of Education and Vocational Training,
Navy Office, Melbourne.
Forwarded.

Commanding Officer,
H.M.A.S. " " / /

(A copy of this order is to be retained in Ship to check with deliveries and in connexion with advice to the Director of Navy Accounts of reference to amounts recovered.)

PRO FORMA OF ADVICE TO DIRECTOR OF NAVY ACCOUNTS.

H.M.A.S. "....."

The sum of £..... has been charged on ledger account of at list page.... of..... Quarter Ledger in respect of Text Book Order H.M.A.S. No.....

Director of Navy Accounts,
Navy Office,
Melbourne.

Commanding Officer.

(629/214/267.)

288.

HONOURS AND AWARDS TO R.A.N. PERSONNEL.

With reference to Navy Order 200 of 1944, the following additional honours and awards have been made to personnel of the Royal Australian Navy:—

1. *For gallantry and devotion to duty.*

O.B.E.

Acting Lieutenant Commander Geoffrey John Cliff, M.B.E.,
G.M. and Bar, R.A.N.V.R.

2. *For gallantry, skill, and devotion to duty in a hazardous enterprise.*

TO BE A COMPANION OF THE DISTINGUISHED SERVICE ORDER.

T/Lieutenant Donald M. N. Davidson, R.N.V.R. (Sp.).

3. *For gallantry and devotion to duty in a hazardous operation.*

BAR TO DISTINGUISHED SERVICE CROSS.

Lieutenant Kenneth Robert Hudspeth, D.S.C., R.A.N.V.R.

4. *For gallant and distinguished service in light coastal craft in successful engagement with the enemy.*

THE DISTINGUISHED SERVICE CROSS.

Lieutenant William Leverrier Fesq, R.A.N.V.R.

5. *For outstanding skill, resolution, and devotion to duty in successful landing at Anzio.*

THE DISTINGUISHED SERVICE CROSS.

Lieutenant Ian Antrobus Harris, R.A.N.V.R.

6. *For gallantry and undaunted devotion to duty.*

THE GEORGE MEDAL.

Lieutenant Leon Verdi Goldsworthy, R.A.N.V.R.

7. *For gallantry, skill, and devotion to duty in a hazardous enterprise.*

THE DISTINGUISHED SERVICE MEDAL.

A/Able Seaman Walter Gordon Falls, S/6543.

A/Able Seaman Andrew William George Huston, B/3312.

A/Able Seaman Arthur Walter Jones, F/3383.

Leading Stoker James Patrick McDowell, B/2575.

MENTION IN DESPACHES.

Lieutenant Hubert Edward Carse, R.A.N.V.R. (Sp.).

Leading Telegraphist Horace Stewart Young, O.N. S/3428.

Able Seaman Kevin Patrick Cain, O.N. B/1506.

A/Able Seaman Mostyn Berryman, O.N. PA/2717.

A/Able Seaman Frederick Walter Lata Marsh, O.N. B/3666.

8. *For zeal, patience, and cheerfulness in dangerous waters.*

MENTION IN DESPACHES.

Acting Commander Frederick Ross James, R.A.N.

Chief Petty Officer John Sandilands, O.N. 1007.

Petty Officer Laurence Walter Edwards, O.N. S/1452.

Petty Officer James Raymond Milican, O.N. 24791.

Petty Officer William Michael Smith, O.N. 13552.

T/Leading Cook (S) William James Craig, O.N. 18027

MENTION IN DESPACHES.

9. (i) *For outstanding courage, skill, and devotion to duty.*

Lieutenant Ernest Harold Richards, R.A.N.V.R.

- (ii) *For good service in Aegean Sea operations.*

Lieutenant Brian Maynard Close, R.A.N.V.R.

- (iii) *For courage, resolution, and skill.*

Able Seaman Albert Edward Hewitt, O.N. F/3976.

- (iv) *For good service in mine sweeping in clearing a passage for force that operated in support of advance of Eighth Army.*

Able Seaman Keith Tame, S/5537.

10. *New Year's Honours List, 1944.*

M.B.E.

Mr. John Stuart Godfrey, Commissioned Gunner, R.A.N.

B.E.M.

Chief Petty Officer Earle Alwin Greglach Boyd, O.N. 7353.

Chief Stoker Harold James Johnston, O.N. 6945.

Engine Room Artificer 3rd Class Albert Fischen, O.N. B/2853.

Master at Arms Valentine George Edward Swallow, O.N.
24792.

Regulating Petty Officer William Charles Gibbings, O.N. 9557.

(448/201/1507.)

(This Order will be reprinted for posting on Notice Boards.)

289.

PROMOTION TO WARRANT WRITER AND WARRANT SUPPLY OFFICER—CONDITIONS.

As from 1st January, 1945, candidates for promotion to Warrant Writer and Warrant Supply Officer will, in addition to qualifying educationally under existing regulations, be required to obtain second-class marks in Practical Mathematics at the Higher Educational Test before sitting for the professional examination. From the same date, the Mathematics paper in the professional examination will be abolished.

2. Candidates who have already qualified educationally and professionally under existing regulations will not be affected by this amendment.

3. Candidates who have already qualified educationally under existing regulations, but who have not yet qualified professionally, will be permitted to sit for the professional examination in December, 1944, but after that date will be required to qualify educationally under the new rule before being eligible to sit for the professional examination.

4. The only exception to paragraph 3 will be in favour of those candidates who, although failing at a previous professional examination, nevertheless obtained 50 per cent. of the marks in the Mathematics paper included in that examination. Such candidates will be regarded as having complied with the new rule.

5. Commencing with the December, 1944 examination, the conditions of the professional examinations for Warrant Writer and Warrant Supply Officer will be amended to bring them into line with one another. The alterations will be:—

(a) *Writer*—

Ledger Ship's Office to be reduced to 300 marks (time allowed three hours).

Typewriting to be reduced to 50 marks.

Mathematics to be reduced to 150 marks.

(b) *Supply*—

Each professional paper to be 300 marks (time allowed three hours).

Mathematics to be reduced to 150 marks.

The total marks for both examinations in December, 1944, will therefore be 750, and thereafter, when the Mathematics paper is abolished, 600. An aggregate of 70 per cent. and 50 per cent. in each subject will be required to pass.

6. K.R. and A.I. Appendix XII, Part 9 (Section IV) and Part 14 are being amended by an Admiralty Fleet Order.

(465/207/1236.)

(*This Order will be reprinted for posting on Notice Boards.*)

290.

R.A.N.R. PETTY OFFICERS—ADVANCEMENT TO CHIEF PETTY OFFICER.

For the duration of the war, it has been decided that R.A.N.R. Petty Officers of the Seaman and Miscellaneous branches who were mobilized as such, shall, before being advanced to Chief Petty Officer, be required to pass the professional examination which would have been applicable for advancement to Petty Officer under existing Regulations and Instructions.

(432/205/5982.)

(*This Order will be reprinted for posting on Notice Boards.*)

291.

APPRENTICES—WAR SERVICE.

When an apprentice enters war service, the indentures of his apprenticeship are suspended, and, on completion of his service, he is required to apply for a revival of the contract. If, however, an apprentice can satisfy the Apprenticeship Commission that he has been employed at and has received instruction in his trade during his war service, the Commission may, under National Security (Apprenticeship) Regulations, approve of the inclusion of such period in the term of his apprenticeship.

2. After service in the Navy equivalent to the unexpired time of his apprenticeship, an apprentice should therefore apply to the Commission for the return of his indentures, his application being accompanied by a certificate from his technical officer through his Commanding Officer, stating the class of training and work undertaken. Provided that the certificate satisfies the Commission that the work and instruction are equal to the training he would normally receive during his apprenticeship, his indentures will be endorsed and returned.

(432/205/5756.)

(*This Order will be reprinted for posting on Notice Boards.*)

292.

ADVANCEMENT OF RATINGS TRAINED IN COMBINED OPERATIONS.

Paragraph 3 of Navy Order 449 of 1943—"Advancement of Ratings Trained in Combined Operations"—is amended as follows:—

Line 1.—For "leading seaman and petty officer" read "leading seaman petty officer and leading stoker".

Line 4.—For the heading "*To Leading Seaman*" read "*To Leading Seaman and Leading Stoker*".

(463/205/2327.)

293.

FAIRMILE RUDDERS.

A case has occurred of a Fairmile Rudder being lost owing to the fracture of the split bronze retaining and adjusting nut, which is situated at the upper end of the rudder stock.

2. Immediate action is to be taken to examine all retaining nuts for soundness.

(603/294/891.)

294.

FAILURES OF ARMAMENT MATERIAL AND AMMUNITION—RENDERING OF FORMS S.1148 (h), (i) AND (j).

1. *Forms S.1148 (i) and (j)*.—Instructions for rendering these forms are given in B.R. 862, Naval Magazine and Explosives Regulations, Articles 310 and 318. These instructions apply to H.M.A. Ships except that the original copy is to be forwarded to the Naval Board through the Senior Naval Officer.

Forms S.1148 (h).—Are to be rendered as follows:—

Original to the Naval Board through the Senior Naval Officer. Duplicate to the Naval Ordnance Inspecting Officer responsible for the port which the ship will next visit.

Paragraphs 1 and 2 of the instructions printed on the top of forms S.1148 (h), Australian Reprint 1938, are cancelled.

2. The Naval Ordnance Inspecting Officers and Armament Supply Officers in Australian waters are as follows:—

Ports in the New Guinea Area and Ports in Queensland except Brisbane:—

Naval Ordnance Inspecting Officer, North Eastern Area, C/o Naval Officer-in-Charge, New Guinea, MILNE BAY.	Superintending Armament Supply Officer, R.A.N. Armament Depot, Spectacle Island, SYDNEY.
---	--

Brisbane and Ports in New South Wales:—

Naval Ordnance Inspecting Officer, R.A.N. Armament Depot, Spectacle Island, SYDNEY.	Superintending Armament Supply Officer, R.A.N. Armament Depot, Spectacle Island, SYDNEY.
--	--

Ports in Victoria, South Australia, and Tasmania:—

Inspector of Naval Ordnance, Naval Ordnance Inspection Branch, Ordnance Factory, MARIBYRNONG, W.3.	Deputy Armament Supply Officer, R.A.N. Armament Depot, Ordnance Factory, MARIBYRNONG, W.3.
--	---

Ports in West Australia:—

Naval Ordnance Inspecting Officer, R.A.N. Armament Depot, Centenary Buildings, William Street, FREMANTLE.	Armament Supply Officer, R.A.N. Armament Depot, Centenary Buildings, William Street, FREMANTLE.
---	---

Ports in Northern Territory:—

Armament Supply Officer, C/o Naval Officer-in-Charge, DARWIN.	(also acts as Naval Ordnance Inspecting Officer).
---	--

3. Navy Order 144 of 1944 is cancelled.

(490/202/1050.)

295.

GAS CYLINDERS—WATER PRESSURE TEST.

The following Departmental gas cylinders are due for periodical water pressure test in accordance with Article 310, clause 5, of the Engineering Manual (1932), and they are to be returned for testing as early as practicable after the contents are exhausted:—

Oxygen Gas Cylinders—

Registered Nos. S13001, S13006, S13017, S13020, S13023,
S13028, S13035, S13047, S13050, S13052, S13056, S13059,
S13060, S13063, S13067, S13068, S13069, S13070, S13089,
S13094, S13095, S13096, S13102, S13108, S13113, S13119,
S13153, S13156, S13163, S13164, S13167, S13169, S13171,
S13175, S13186, S13191, S13193, S13198.

Hydrogen Gas Cylinders—

Registered Nos. 549991, 549932, 24760, 13, 31683, 872676, 31912,
and 31644.

Coal Gas Cylinders—

Registered Nos. S13002, S13006, S13008, S13009, S13010.

CO₂ Gas Cylinders—

Registered Nos. S13016, S13083, S13131, S13140, S13146,
S13213, S13228, S13236, S13252, S13264, S13272, S13295,
S13296, S13298, S13303, S13333, S13336, S13347, S13348,
S13349, S13351, S13354, S13358, S13361, S13362, S13367,
S13376, S13399, S13403, S13404, S13410, S13428, S13429,
S13432, S13434, S13442, S13454, S13466, S13468, S13470,
S13472, S13474, S13475, S13488, S13490, S13492, S13493,
S13494, S12177, 180, 1996, 5621, 6290, 6616, 6669, 8674,
8970, 9421, 9748, 9843, 9924, 12136, 12120, 12151, 12159,
25995, 2599, C412, 2317, 6025, 6215, 9740, 9766, 5564, 2206,
1261, 944, 7212, 12076, 34, and 7394.

2. Establishments should arrange for the necessary tests to be carried out locally where facilities exist for testing and recharging, otherwise the cylinders are to be returned to the nearest Naval Store Depot for necessary action.

3. Particulars of tests carried out by Naval Establishments are to be furnished to the Naval Officer-in-Charge, Sydney, for insertion in the relevant History Sheets of the Cylinders.

(669/201/1072.)

296.

INSTRUCTIONAL FILMS—DISPOSAL OF OBSOLETE AND UNSERVICEABLE FILMS.

All unserviceable and obsolete instructional films, or parts thereof, held by H.M.A. Ships and Shore Establishments are to be carefully packed and returned to the Superintending Naval Store Officer, Sydney, for survey, the case being landed at the nearest Naval Store Depot for onward despatch.

2. The survey of the films returned will be carried out periodically by the Cinema Maintenance Officer attached to Navy Office, or his representative.

3. Particular attention is to be given to the high degree of inflammability of cinema film, and the necessity for care in package and storage thereof.

(560/201/1263.)

297.

SUPPLY OF SPECTACLES—DELEGATION OF AUTHORITY.

With reference to Naval Financial Regulations and Instructions, Article 190, clause 2, it has been decided, as a wartime measure, to delegate to Naval Officers-in-Charge in each State of the Commonwealth authority for the grant or refusal of spectacles where the proposed supply is to a rating (including members of the W.R.A.N.S.) in a branch permitted to wear spectacles, and such supply is recommended by an Ophthalmic Specialist.

2. Form A.M. 250Z is to be prepared in each case and submitted to the Naval Officer-in-Charge, who, if the supply is in order, will approve and will sign the form in lieu of the Director of Naval Medical Services. At the end of each month, the forms A.M. 250Z for those spectacles supplied during the month are to be forwarded to the Director of Naval Medical Services.

3. In cases where spectacles are recommended for ratings in those branches not permitted to wear them, or for a Wran V/S rating, Form A.M. 250Z is to be submitted to the Director of Naval Medical Services for decision.

(527/211/2013.)

298.

INTRODUCTION OF FORM A.S. 155X—RECORD OF NAVAL STORE LEDGERKEEPERS.

In order that a permanent record of the names of ratings employed as Naval Store Ledgerkeepers may be maintained in H.M.A. Ships and Establishments in which the standard Naval Storekeeping procedure as laid down in B.R. 4 (Manual of Naval Storekeeping) is in force, Form A.S. 155X—"Record of Naval Store Ledgerkeepers" has been introduced.

2. Form A.S. 155X which will be of the same size as existing Forms A.S. 155a, b and c., provides for a month to month record of the names and rating of personnel employed as ledgerkeepers, and each sheet will provide for 24 months. Particulars of the names and rating of all ledgerkeepers so employed should be entered monthly in the appropriate columns on the form which is to be initialled monthly by the Storekeeping Officer and retained in the Binder for the Register of Ledger pages available for inspection during examination of Naval Store Accounts.

3. Form A.S. 155X is being printed and will be distributed by the Superintending Naval Store Officer, Garden Island, Sydney, without demand.

(480/202/4129.)

299.

BOOKS AND FORMS.

1. B.R. 145 (43). With reference to Navy Order 247 of 1944, O.N.I 220m.—Axis Submarine Manual—is to be accounted for as B.R. 145 (43).

(A.F.O. 232/44.)

(571/201/4087.)

2. The under-mentioned forms have been revised. Supply will be effected, on demand, when stock of the existing forms is exhausted:—

A.S. 41b (outside).

A.S. 41b (inside).

Summary of Quarterly Ledger.

(480/202/4567.)

3. The under-mentioned form has been introduced for use in the Royal Australian Navy in lieu of the corresponding Admiralty form. Supply will be effected, on demand, when stock of the existing form is exhausted:—

A.S. 1246b—Electrical Artificers.

History Sheet.

(480/202/4558.)

RESTRICTED.(FOR OFFICIAL USE ONLY.)

Commonwealth Navy Orders.

Navy Office, Melbourne,
20th June, 1944.

The following Orders, having been approved, are hereby promulgated for information and guidance, and necessary action.

By direction of the Naval Board,

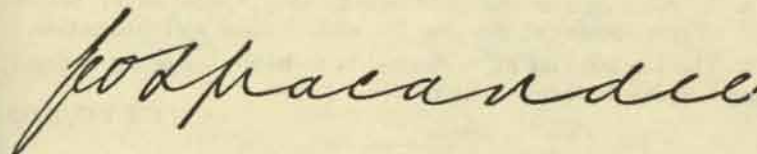

Secretary.

*The Commodore Commanding H.M.A. Squadron,
and Commanding Officers of H.M.A. Ships,
Officers in Charge of H.M.A. Naval
Establishments, and others concerned.*

TABLE OF CONTENTS.

No.	Subject.
300.	Confidential Correspondence—Registration.
301.	Confirmation and Promotion of Naval Reserve Officers.
302.	Officers Discharged or Demobilized.
303.	Cash Advances to H.M.A. Ships from U.S. Ships.
304.	Release of Personnel for Dairying Industry.
305.	Rates of Treatment in Private Hospitals with Approved Accommodation for Naval Officers.
306.	Guns, Q.F. 40 m.m.—Method of Testing Blow of Striker.
307.	Ammunition—20 m.m. Oerlikon H.E. Tracer, Lot N.F.H. 2257 F—Withdrawal.
308.	Ammunition—20 m.m. Oerlikon H.E. Tracer, Lot N.F.H. 10 B/45—Withdrawal.
309.	Ammunition—20 m.m. Oerlikon H.E., Lot H.N.C. 13—Withdrawal.
310.	Ammunition—20 m.m. Oerlikon H.E., Lot N.F.E. 404—Withdrawal.
311.	W/T, A/S, Radar, &c., Equipment—Establishment Lists.
312.	Medal Ribbons—Wearing with Tropical Dress.
313.	Printed Forms.
314.	Sperry Mk. XIV—Mod. 1 Gyro Compass—Incorrect Fitting of Transmitter Connecting Cables.
315.	Naval Armament Stores in D.E.M.S.—Accounting Procedure.

300.

CONFIDENTIAL CORRESPONDENCE—REGISTRATION.

With reference to C.O.R., Article 337, in view of the recent revision of Secrecy Classifications, "Confidential" correspondence and documents are in future to be treated in the same manner as "Secret" matter.

2. C.O.R., Article 337, will be amended in due course.
(443/201/1323.)

301.

CONFIRMATION AND PROMOTION OF NAVAL RESERVE OFFICERS.

Attention is drawn to the Promotion Circulars sent from time to time to Commanding Officers and Administrative Authorities concerning the confirmation and promotion of Naval Reserve Officers. These circulars are sent to assist authorities concerned in order that the requisite recommendations shall reach Navy Office on or before the dates officers concerned are due for confirmation and promotion.

2. The attention of all concerned is to be drawn to the necessity of prompt replies to these circulars.

(432/205/6050.)

302.

OFFICERS DISCHARGED OR DEMOBILIZED.

A certificate in the following terms will in future be issued to all officers upon discharge or demobilization from the Royal Australian Navy and Reserves (including Women's Services).

CERTIFICATE OF DISCHARGE OF AN OFFICER.

This is to certify that (a).....
who entered for full-time War Service in the Royal Australian Navy on.....day of19...., has served as a
(b).....officer of the
(c).....from the.....day of
.....19...., to the.....day of
.....19...., on which latter date (d).....
was demobilized with the approval of the Naval Board. This Officer's
Service included (e).....

Secretary, Naval Board.

Signature of Officer.....

NOTES.

- (a) Insert rank, name in full, and Decorations.
(b) Insert Commissioned or Warrant Officer.
(c) Insert in full—

R.A.N.
R.A.N.R. (S).
R.A.N.R.
R.A.N.V.R.
R.A.N.N.S.
W.R.A.N.S.

- (d) Insert—he or she.
(e) Insert—Active Service in Australia, and/or Active Service outside Australia, and/or Active Service at sea.

2. Paragraph 1 (a) of Navy Order 409 of 1942 is cancelled.

(629/214/209.)

303.

CASH ADVANCES TO H.M.A. SHIPS FROM U.S. SHIPS.

Where cash advances are made to H.M.A. Ships by United States Ships, the financial adjustment between the Commonwealth and the United States Governments is effected in Washington.

2. For this purpose Commanding Officers of H.M.A. Ships should inform the Director of Navy Accounts, Melbourne, by signal, of any such advance on the date it is received. As adjustment will be arranged by Navy Office on receipt of this advice, no other authorities should be informed.

3. The advice should state the amount received in American currency, and also the Australian currency equivalent converted at the rate of 3·228 dollars to £1 Australian.

(405/201/778.)

304.

RELEASE OF PERSONNEL FOR DAIRYING INDUSTRY.

In view of the acute manpower position in regard to dairying, the Naval Board are prepared to consider applications for demobilization from personnel who have been previously employed in this industry, to enable them to return thereto. Release from the Navy will be subject to requirements of the Service especially as regard specialist qualifications, higher rating or non-substantive rating held.

2. The procedure to be followed in dealing with these cases is:—
- (a) Application should be made to the Deputy Director-General of Manpower of the State in which the dairy farm is situated, giving details of former dairying employment, including names and addresses of employers, period of employment, &c.
- (b) Deputy Director-General of Manpower should be informed that, provided he recommends release and authorizes the entry of an additional recruit as a replacement, the Naval Board will give every consideration to the member's release subject to requirements of the Naval Service.
- (c) Deputy Director-General of Manpower should be requested to forward his recommendations to the ship or establishment making the application; the Commanding Officer should then forward completed application and enclosures for the consideration of the Naval Board.

3. Cases have occurred where personnel have applied directly to the Manpower Authorities to effect their release from the Service. It should be made generally known that such applications must be made through the Commanding Officer concerned.

(535/203/240.)

(This Order will be reprinted for posting on Notice Boards.)

RATES OF TREATMENT IN PRIVATE HOSPITALS WITH APPROVED ACCOMMODATION FOR NAVAL OFFICERS.

With reference to Navy Orders 50 of 1940, 74 of 1941, 205 of 1942, and 217 of 1943, the agreements with the Private Hospitals indicated therein, with slight variations, have been renewed until the 28th February, 1945.

2. Preference is to be given to the hospital with the lower rate of charge if accommodation is available and suitable for the case concerned.

3. Attention is directed to the provision of C.O.R., Article 548, clause 1, regarding class of accommodation allowed, and to clause 2 concerning preparation of vouchers for payment of claims.

4. The Navy Orders indicated above are hereby cancelled.

5. The rates of treatment for the year commencing 1st March, 1944, are shown hereunder:—

Name and Address of Hospital.	Private Room— (a) per Day. (b) per Week.	Two or more in Room— (a) per Day. (b) per Week.	Operating Theatre Charges— (a) Major. (b) Minor.	Charge for Special Nurses per Week.	Number of Beds Available.	Class of Case Taken.	Remarks.
<i>New South Wales—Sydney—</i> "Jenner," 2 Macleay-street, Potts Point. (Tel. FL.2113)	(a) 24s. (b) 168s.	Two or more in room— (a) 15s. (b) 105s.	(a) 42s. (b) 21s.	Day Nurse, 94s. 6d. and expenses plus board. Night Nurse, 116s. 6d. and expenses plus board	As beds are available	Medical and Surgical only	
"St. Luke's," 18 Roslyn-street, Darlinghurst. (Tel. F.2181)]	(a) 21s. to 30s. (b) 147s. to 210s.	Two in room— (a) 18s. (b) 126s. Three in room— (a) 15s. (b) 105s.	(a) 52s. 6d. (b) 31s. 6d.	Night and Day Nurse, 84s. plus board	Varying number available from time to time	Medical and Surgical only	
<i>Tasmania—Hobart—</i> "St. Helen's," 186 Macquarie-street. (Tel. 4109)	(a) 12s. (b) 84s.	(a) 9s. (b) 63s.	(a) 21s. (b) 10s. 6d.	Night and Day Nurse (including board), 105s. 1st week, 89s. subsequent weeks	16	All cases except infectious Public Health notification cases	Discount 5 per cent.—30 days
"Stowell," Stowell-avenue, Battery Point. (Tel. 4877 and 4878)	(a) 14s. to 20s. (b) 100s. to 140s., according to type of room available	(a) 11s. 6d. (b) 80s.	(a) 31s. 6d. (b) 12s. 6d.	Rate for Special Nurses not contracted for because their fees are handled entirely by the Nurses Club	36 (usually 5 to 10 beds available)	Medical and Surgical only	Discount 5 per cent.
"St. John's," C. of E. (Incorporating Hobart Homeopathic Hospital, 30 Cascade-road. (Tel. 5089)	(a) 18s. (b) 126s.	(a) 10s. (b) 70s.	(a) 42s. (b) 26s.	Day and Night Nurse (including board) 105s.	21	Medical and Surgical only	All rates less 10 per cent.
<i>Victoria—Geelong—</i> "Riviera," 80 Myers-street. (Tel. 1278)	(a) 16s. 6d. and 19s. 6d. (b) 115s. 6d. and 136s. 6d.	(a) 12s. (b) 84s.	(a) 42s. (b) 21s.	Day and Night Nurse (including board) 114s.	Several	Medical and Surgical only	
<i>Queensland—Brisbane—</i> "St. Helen's," Stanley-street, South Brisbane. (Tel. J.2213)	(a) 16s. 6d. to 21s. (b) 115s. 6d. to 147s. (according to type of room available)	Two in room— (a) 13s. 6d. (b) 94s. 6d. More than two— (a) 13s. (b) 90s.	(a) 42s. (b) 21s.	Night and Day Nurse, 84s. plus 35s. for board, 3s. 6d. for Laundry and Fares	39	Medical and Surgical only.	10 per cent. discount allowed on maintenance and operation charges only
"Gregory," Gregory-terrace, Brisbane. (Tel. B.7371)	(a) 15s. to 21s. (b) 105s. to 147s. (according to type of room available)	(a) 13s. 6d. (b) 94s. 6d.	(a) 42s. (b) 21s.	Night and Day Nurse 21s. first day. Two days and over 84s. per week plus 5s. per day for board	18	Medical and Surgical only	
<i>South Australia—Adelaide—</i> "Memorial Inc.," Pennington-terrace, North Adelaide. (Tel. C.2302)	(a) 12s., 15s., 16s. 6d., or 18s. (b) 84s., 105s., 115s. 6d., or 126s., according to type of room available	Two in room— (a) 12s. (b) 84s. More than two— (a) 9s. (b) 63s.	(a) 42s. (b) 31s. 6d.	Night and Day Nurse (including board) 84s.	115	Medical and Surgical only	25 per cent. discount allowed on maintenance charges only for personnel with War Service
"Wolverton," 122 Esplanade. Semaphore. (Tel. Y.6423)	(a) 16s. 6d. (b) 115s. 6d.	(a) 13s. (b) 90s. Ward cases— (a) 11s. 6d. (b) 80s.	(a) 42s. (b) 21s.	Night and Day Nurse (including board) 85s.	20	Medical and Surgical only	
"Hutt Street," 121 Hutt-street, Adelaide. (Tel. C.4293)	(a) 13s. 6d. or 15s. (b) 90s. or 105s. (according to type of room available)	(a) 10s. (b) 70s.	(a) 42s. (b) 21s.	Night and Day Nurse (including board) 78s.	30	Medical and Surgical only	10 per cent. discount allowed for personnel with War Service
<i>Western Australia—</i> St. John of God, Subiaco	(a) 15s. to 18s. (b) 105s. to 126s. (according to type of room available)	(a) 12s. (b) 84s.	(a) 42s. (b) 21s.				Fees cover nursing charges, and includes the usual drugs and dressings such as the supply and administering of morphia or barbitone, but do not cover cases such as pneumonia, cardia, and amputations

With the exception of St. John of God charges, as indicated in the "Remarks" column, the cost of drugs, dressings, X-rays, etc., are extra.

306.

GUNS, Q.F. 40 M.M.—METHOD OF TESTING BLOW OF STRIKER.

The following instructions are to be carried out when testing the blow of striker of Guns, Q.F. 40 m.m.:

- (1) Prepare the gauge testing blow of striker as follows:—
 - (a) Insert the thin steel plug unlubricated into the gauge.
 - (b) Measure the copper with a micrometer and then insert it (unlubricated) on top of the thin steel plug, base first.
 - (c) Lightly grease the thick steel plug to prevent it jumping out of the gauge, and insert it on top of the copper. If an excessive amount of grease is used, the blow will be cushioned and the reading obtained will be false.
- (2) With the gun in depression open the top cover.
- (3) Pull back on the hand operating lever until the breech block is opened sufficiently for the gauge to enter the chamber, but not for the extractors to hook on the block. Insert the gauge, using a piece of wood to press the rim of the gauge against the barrel face. Allow the breech block to rise until the gauge is partly covered.
- (4) Place the hand operating lever smartly in the forward catch.
- (5) Open the breech and remove the gauge.
- (6) Force out the steel plugs and the copper from the front, using the drift provided.
- (7) Measure the copper with a micrometer and determine the compression by subtracting this measurement from that obtained in (1) (b) above.
- (8) Repeat (1) to (7) above, twice, and determine the mean compression on the three coppers used.
- (9) Convert the mean compression to inch lbs. by means of Table "A" in B.R.291. The answer is the blow of the striker, which should not be below the minimum shown in Table "B" in that B.R.

(490/212/1100.)

307.

AMMUNITION—20 M.M. OERLIKON H.E. TRACER, LOT N.F.H. 2257F—WITHDRAWAL.

Appended, for information and necessary action, is copy of Admiralty Fleet Order 1528/44 which has not yet been promulgated on the Australia Station:—

"Twenty millimetre Oerlikon H.E. tracer ammunition of lot N.F.H. 2257F has caused missfires owing to insensitivity of the caps and is to be withdrawn from service.

2. Ammunition of this lot on board ships is to be returned to the nearest Naval armament depot or Officer-in-Charge of armament supply, at the first opportunity, and ammunition of other lots drawn in lieu.

3. D.E.M.S. Staff Officers are to arrange for similar action to be taken in merchant ships.

4. H.E. tracer ammunition of this lot in store at Naval armament depots, or subsequently received, should be brought to produce."

(408/206/1416.)

308.

AMMUNITION—20 M.M. OERLIKON H.E. TRACER, LOT N.F.H. 10B/45—WITHDRAWAL.

Appended, for information and necessary action, is copy of Admiralty Fleet Order 1819/44 which has not yet been promulgated on the Australia Station:—

"20 m.m. Oerlikon H.E. tracer ammunition of lot N.F.H. 10B/45 has caused missfires and is to be withdrawn from service.

2. All ammunition of this lot on board ships is to be returned to the nearest Naval Armament Depot or Officer-in-Charge of Armament Supply at the first opportunity and ammunition of other lots drawn in lieu.

3. D.E.M.S. Staff Officers are to arrange for similar action to be taken in merchant ships.

4. H.E. tracer ammunition of this lot in store at Naval Armament Depots or subsequently received should be brought to produce."

(408/206/1417.)

309.

AMMUNITION—20 M.M. OERLIKON H.E., LOT H.N.C. 123—WITHDRAWAL.

Appended, for information and necessary action, is copy of Admiralty Fleet Order 1820/44 which has not yet been promulgated on the Australia Station:—

20 m.m. Oerlikon H.E. ammunition of lot H.N.C. 123 has caused stoppages owing to the caps of the cartridges blowing out when using Mark II breech face pieces and is to be withdrawn from service.

2. All ammunition of this lot on board ships is to be returned to the nearest Naval Armament Depot or Officer-in-Charge of Armament Supply at the first opportunity and ammunition of other lots drawn in lieu.

3. D.E.M.S. Staff Officers are to arrange for similar action to be taken in merchant ships.

4. H.E. ammunition of this lot in store at Naval Armament Depots or subsequently received should be brought to produce."

(408/206/1418.)

310.

**AMMUNITION—20 M.M. OERLIKON H.E., LOT N.F.E. 404—
WITHDRAWAL.**

Appended, for information and necessary action, is copy of Admiralty Fleet Order 1821/44 which has not yet been promulgated on the Australia Station:—

“20 m.m. Oerlikon H.E. ammunition of Lot N.F.E. 404 has caused stoppages owing to the caps of the cartridges blowing out when using Mark II breech face pieces and is to be withdrawn from service.

2. All ammunition of this lot on board ships is to be returned to the nearest Naval Armament Depot or Officer-in-Charge of Armament Supply at the first opportunity and other lots drawn in lieu.

3. D.E.M.S. Staff Officers should arrange for similar action to be taken in merchant ships.

4. H.E. ammunition of this lot in store at Naval Armament Depots or subsequently received should be brought to produce.”

(408/206/1419.)

311.

W/T, A/S, RADAR, ETC., EQUIPMENT—ESTABLISHMENT LISTS.

With reference to Navy Order 139 of 1944, distribution of Establishment Lists for the equipments referred to in paragraph 5 thereof will in future be made in accordance with the scale included in the appendix to this Order. The distributing authority will be the Superintending Naval Store Officer, Sydney.

2. In respect of equipments already fitted, it is desired to ascertain requirements of Establishment Lists to complete ships, &c., in accordance with the scale referred to in paragraph 1 of this Order. Returns are accordingly to be forwarded to the Superintending Naval Store Officer, Sydney, by all ships, &c., setting out:—

(a) The number of copies of relevant Establishment Lists already held.

(b) Additional copies required to complete in accordance with this Order.

**SCALE OF DISTRIBUTION OF ESTABLISHMENT LISTS FOR W/T, A/S,
RADAR, ETC., EQUIPMENT.**

Type of Equipment to which Applicable.	Distribution.	Remarks.
W/T and/or R/T..	A, B, C	A = <i>H.M.A. Ships and Naval Establishments.</i> —Two copies of all Establishment Lists applicable to the various sets fitted. One of these copies is required by the Store Accounting Officer for permanent loan list purposes and as an Establishment, the other copy being for the use of the Professional Officer concerned. Superintending Naval Store Officer, Sydney. Naval Store Officer, Brisbane, Naval Store Officer, Fremantle, Officer-in-Charge, Naval Store Depot, Melbourne—2 copies each

**SCALE OF DISTRIBUTION OF ESTABLISHMENT LISTS FOR W/T, A/S, RADAR, ETC.,
EQUIPMENT—continued.**

Type of Equipment to which Applicable.	Distribution.	Remarks.
WA/T	A, B, C	B = <i>Squadron and Flotilla Officers, &c.</i> —One copy of all Establishment Lists applicable to sets fitted in ships comprising the Squadron or Flotilla, &c., for use of the Squadron/Flotilla, &c. Officer concerned
Sound Reproduction	A, B, C	
VC/VF	A, B, D	C = <i>Naval Officers-in-Charge, Sydney, Brisbane, Fremantle, Darwin, Port Melbourne, New Guinea.</i> —One copy of each list. (For use of Port W/T Officer.)
A/S	A, B, E, F	D = <i>Naval Officers-in-Charge, Sydney, Brisbane, Townsville, Cairns, New Guinea, Darwin, Fremantle.</i> —One copy of each list. (For use of Port Signal Officer.)
E/S	A, B, E, F	E = <i>Naval Officers-in-Charge, Fremantle, Port Melbourne, Brisbane, Cairns, Darwin, Townsville.</i> —Two copies of each list. (For Port A/S Officer.)
Hydrophone ..	A, B, G	F = <i>Naval Officer-in-Charge, New Guinea, Rushcutter.</i> —Three copies of each. (For Port A/S Officer.)
Radar	A, B, H, I	G = <i>Rushcutter.</i> —Three copies of each
		H = <i>Naval Officers-in-Charge, Sydney, Brisbane, Fremantle, Darwin, New Guinea, Townsville, Cairns, Port Melbourne (for Port Radar Officers), Port Adelaide (for Radar Fitting Officer), and H.M.A. Radar School.</i> —Two copies of each local Radar Establishment List. (For Port Radar Officer.)
		I = <i>Naval Officer-in-Charge, Fremantle and H.M.A. Radar School.</i> —One copy of each Admiralty and Local Radar Establishment List for Survey Depot

(1903/2/862.)

312.

MEDAL RIBBONS—WEARING WITH TROPICAL DRESS.

In towns where tropical dress is the rig of the day, ties and medal ribbons may be worn at the discretion of the Naval Officer-in-Charge.

(448/201/1890.)

313.

PRINTED FORMS.

With reference to Navy Order 186 of 1944, "A.T.810z" in paragraph 3 should read "A.T.801z".

(480/201/3261.)

314.

SPERRY MK. XIV—MOD. 1 GYRO COMPASS—INCORRECT FITTING OF TRANSMITTER CONNECTING CABLES.

Errors in the Master Gyro Compass in ships fitted with Sperry Mark XIV Mod. 1 Gyro Compass equipments, when on certain courses, have been due to the follow-up transformer armature, mounted on the sensitive element, touching the positive supply cable to the centre contact arm of the transmitter, mounted on the spider element.

2. The positive supply cable to the centre contact arm of the transmitter should be carried over the top of the contact bracket as shown in the appended diagram. Ship's Staff are to examine the cable as soon as practicable, and are to exercise care after renewal or repair, to ensure correct assembly.

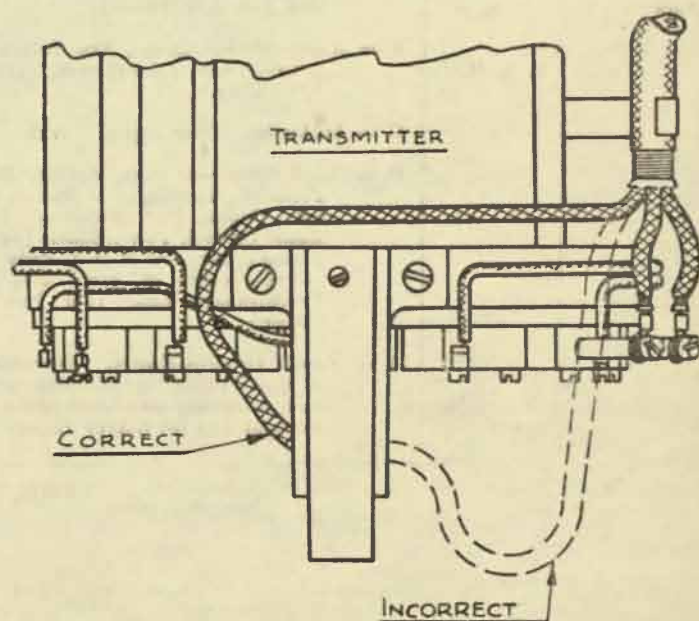

SPERRY MK. XIV GYRO COMPASS
FITTING OF TRANSMITTER CONNECTING CABLES.

(NOT TO SCALE.)

(670/202/1235.)

315.

NAVAL ARMAMENT STORES IN D.E.M.S.—ACCOUNTING PROCEDURE.

It has been decided to adopt for Commonwealth D.E.M. Ships the modified procedure laid down in Admiralty Fleet Order 503/43 in regard to simplification of accounting for Naval Armament Stores.

2. D.E.M.S. Staff Officers are to withdraw Forms F.A.30 and/or O.17 from Commonwealth D.E.M.S. and forward them by registered post to the Director of Ordnance, Torpedoes and Mines, Navy Office, Melbourne. Supporting Issue and Receipt Vouchers should *not* be forwarded with the Form, but should be retained with D.E.M.S. Form 15 (b). Care should be taken that all relevant particulars in regard to the ship's armament are included in D.E.M.S. 15 (b), before the Ledger is despatched.

3. Form 15 (b) is to be inspected and stock verified quarterly, and an entry that this has been done, together with result, is to be entered on Form 15 (b) and D.E.M.S. 4, by D.E.M.S. Staff Officers.

(612/204/1523.)

RESTRICTED.(FOR OFFICIAL USE ONLY.)

Commonwealth Navy Orders.

Navy Office, Melbourne,

27th June, 1944.

The following Orders, having been approved, are hereby promulgated for information and guidance and necessary action.

By direction of the Naval Board,

J. P. Macandee
Secretary.

*The Commodore Commanding H.M.A. Squadron,
and Commanding Officers of H.M.A. Ships,
Officers in Charge of H.M.A. Naval
Establishments, and others concerned.*

TABLE OF CONTENTS.

No.	Subject.
316.	Appointments.
317.	Port Directors.
318.	Educational Test I, March, 1944.
319.	Naval Watchkeeping Certificate—Naval Reserve Officers.
320.	D.E.M.S.—Ratings—Drafting, Records, &c.
321.	Personnel Serving at Northern Bases.
322.	Advancement to Chief Shipwright—Qualifications.
323.	Cremation of Deceased Service Personnel.
324.	Rockets, Target Practice Mark I*. Lots 129 and 144—Withdrawal—Reports.
325.	Ammunition Outfits of Small Ships—Arrangements for Periodical Exchange, Examination, &c.
326.	Ammunition, &c.—Weekly Report of Stock by Shore Establishments on Form A.O. 5Z.
327.	4-in. Mark XXIII* Mountings—Illumination of Sight Dials.
328.	Carriers Ammunition Double for O.Q.F. 4-in. Mark XIX and O.Q.F. 4-in. Mark XVI*.
329.	Microphotographic X-Ray Examinations.
330.	D.E.M.S. Gunnery Equipment—Painting of.
331.	Supply of Canteen Stores.

316.

APPOINTMENTS.

Commodore of the First Class John A. Collins, C.B., assumed duty as Commodore Commanding, H.M.A. Squadron and Commander, Task Force 74, on 13th June, 1944, *vice* Rear-Admiral Victor A. C. Crutchley, V.C., D.S.C.

2. Correspondence is to be addressed to the Commodore Commanding, H.M.A. Squadron or the Commander, Task Force 74, as applicable.

(1804/2/21.)

317.

PORT DIRECTORS.

With reference to Navy Orders 526 of 1943, and 148 and 199 of 1944, the Port Directorates at Goodenough and Kiriwina Islands have now been closed.

2. A Port Director has been appointed at Madang.

(1937/2/232.)

318.

EDUCATIONAL TEST I, MARCH, 1944.

The following ratings passed Educational Test I, held on the 21st March, 1944:—

Name.	Rating.	Official Number.
<i>H.M.A.S. Arunta.</i>		
Wilson, Edward L.	Stoker 2nd Cl.	26663
<i>H.M.A.S. Cerberus.</i>		
Barnes, John F.	Stoker 2nd Cl.	B/4994
Bradley, William S.	Able Seaman	20211
Douglas, Harold M.	A/Joiner, 4th Cl.	PM/6538
Irvine, Robert W.	Stoker, 2nd Cl.	F/5227
Johansen, William J.	Stoker, 2nd Cl.	PA/4420
King, John T.	Stoker, 2nd Cl.	W/2965
Lakeland, Harry W.	Stoker, 2nd Cl.	W/3000
Law, Thomas	Able Seaman	W/1266
Leonard, Francis J.	Stoker, 2nd Cl.	PA/4105
Magill, Clifton R.	Stoker, 2nd Cl.	B/4908
Mobsby, Henry J.	Stoker, 2nd Cl.	S/9030
McArthur, Donald G.	Stoker, 2nd Cl.	W/2951
Neilson, Wilfred O. J.	Stoker	H/2271
Palassis, Nicholas B.	Stoker	F/5222
Prior, William H. G.	Stoker, 2nd Cl.	PA/4558
Punshon, Frederick R.	Stoker, 2nd Cl.	W/3003
Quinn-Frake, Geoffrey	Stoker, 2nd Cl.	W/3022
Rawnsley, John	Stoker, 2nd Cl.	PA/4517
Roberts, Dallas W.	Stoker, 2nd Cl.	S/9031
Ross, Colin B.	Stoker	W/1936
Rowe, John N.	Stoker, 2nd Cl.	W/2947
Sanderson, Peter J.	Stoker, 2nd Cl.	W/2976
Schumann, Raymond H.	Stoker, 3rd Cl.	S/9195
Scott, Donald B.	Stoker, 2nd Cl.	S/9106
Semmens, Leslie	Stoker, 2nd Cl.	W/2936
Shipp, Bruce D.	Stoker	H/1810
Stirzaker, John B.	Stoker, 3rd Cl.	PA/4305
Thomas, Victor F.	Stoker, 2nd Cl.	B/4891
Uttley, Jack	Stoker	F/3247
Vinson, William G.	Stoker, 2nd Cl.	PA/4368
Warner, Francis	Stoker, 2nd Cl.	PA/2193
Wright, Lyle E.	Stoker, 2nd Cl.	W/2878

EDUCATIONAL TEST I, MARCH, 1944—continued.

Name.	Rating.	Official Number.
<i>H.M.A.S. Inverell.</i>		
Jones, Arthur D.	Stoker	H/1795
Shanahan, Peter B.	Tel.	B/V76
Sigg, John P.	Able Seaman	S/7149
<i>H.M.A.S. Ladava.</i>		
Blake, Max N.	Ord. Tel.	S/8001
Lillico, Quentin J.	Ldg. Sig.	PM/4914
Matheson, Kenneth J.	Ord. Sig.	PM/6451
Nicholas, Russell E.	Ord. Sig.	PA/4161
Norman, Ashton J.	Stoker	PA/2670
Tidex, Burke G.	Tel.	PM/5793
Willis, Leo D.	Stoker	H/2037
<i>H.M.A.S. Melville.</i>		
O'Leary, Claude E.	Stoker	S/8212
<i>H.M.A.S. Moresby.</i>		
Fentiman, Phillip S.	Ordinary Seaman	B/4117
O'Sullivan, James DeC.	Able Seaman	B/3760
Wilson, Roy G.	Able Seaman	B/3786
<i>H.M.A.S. Penguin.</i>		
Hourigan, James H.	Able Seaman	S/4304
<i>H.M.A.S. Shropshire.</i>		
Boorn, Eric L.	Able Seaman	23248
Bouden, Murray J. D.	Tel.	PA/1716
<i>H.M.A.S. Torrens (Mary Cam).</i>		
Lawrence, Albert W. R.	Stoker, 2nd Cl.	PA/4199
Reuter, Malcolm	A/Stoker	PA/3152
Shillum, John G.	Stoker, 2nd Cl.	PA/4106
<i>H.M.A.S. Westralia.</i>		
Drake, Stanley O.	Able Seaman	S/6857
Fraser, Wallace	Ord. Tel.	PA/3481
Graham, Harvey R.	Able Seaman	B/3912
Mahony, William J. P.	Tel.	H/2129
The following qualified educationally for Acting Leading Stoker:—		
<i>H.M.A.S. Cerberus.</i>		
Barnwall, Robert J.	Stoker, 2nd Cl.	W/2972
Burgess, Douglas E.	Stoker, 2nd Cl.	H/2606
Falla, Reginald J.	Stoker, 2nd Cl.	B/4874
Meade, Alan R.	Stoker, 2nd Cl.	W/3001
Miller, Edward C.	Stoker, 2nd Cl.	F/5213
Thorpe, Ronald S.	Stoker, 2nd Cl.	F/5282
<i>H.M.A.S. Melville.</i>		
Shadbolt, Benjamin J.	Stoker	S/8215
<i>H.M.A.S. Torrens (Mary Cam).</i>		
Carruthers, Thomas J.	Stoker, 2nd Cl.	PA/4243

(This Order will be reprinted for posting on Notice Boards.)

(465/205/663.)

319.

NAVAL WATCHKEEPING CERTIFICATE—NAVAL RESERVE OFFICERS.

With reference to Navy Order 256 of 1944—"Naval Watchkeeping Certificates—Naval Reserve Officers"—paragraph 5, for the words "not less than 50 per cent" read "not less than 60 per cent".

(453/202/962.)

320.

D.E.M.S.—RATINGS—DRAFTING, RECORDS, ETC.

The D.E.M.S. Staff Officer at Sydney has been appointed as the Drafting Authority for all Royal Australian Navy D.E.M.S. Ratings, and is authorized to communicate direct with D.E.M.S. Staff Officers at other Ports on routine matters which do not affect the local Naval Officer-in-Charge.

2. D.E.M.S. Staff Officers at all other Ports are to report daily all movements of D.E.M.S. personnel by signal to the D.E.M.S. Staff Officer, Sydney, repeating such signals to the Naval Board, Naval Officer-in-Charge, Flinders Naval Depot, and other local authorities concerned.

3. Movements of Royal Navy and Royal Australian Navy D.E.M.S. personnel to and from ships of British Register are to be reported by signal to Director of Trade Division, Admiralty, as before, but repeated to other authorities shown in paragraph 2.

4. (a) Movements of both Royal Navy and Royal Australian Navy D.E.M.S. personnel to and from all D.E.M. Ships are to be confirmed on the Friday of each week on Forms D.E.M.S.3 "Weekly Return of Movements of Naval personnel borne in D.E.M.S."

(b) Forms D.E.M.S.3 are to be rendered to D.E.M.S. Staff Officer, Sydney, by all other D.E.M.S. Staff Officers and copies forwarded to the Secretary, Naval Board, and Naval Officer-in-Charge, Flinders Naval Depot. D.E.M.S. Staff Officer, Sydney, will render Forms D.E.M.S.3 in respect of movements at that port to Secretary, Naval Board, and Naval Officer-in-Charge, Flinders Naval Depot.

(c) In order that Director of Trade Division, Admiralty, will be advised of the movement of Royal Australian Navy personnel to and from ships of British Register and all movements of Royal Navy D.E.M.S. personnel, details are to be extracted by D.E.M.S. Staff Officer, Sydney, from all Forms D.E.M.S.3 received by him and reported to Director of Trade Division, Admiralty, on a Form D.E.M.S.3.

5. D.E.M.S. Staff Officers at the various Ports are to forward recommendations for advancement, G.L. Course, &c., to D.E.M.S. Staff Officer, Sydney, who will in turn forward a complete return to Naval Officer-in-Charge, Flinders Naval Depot.

6. Arrangements for gunnery courses, &c., are to be made between D.E.M.S. Staff Officer, Sydney, and Naval Officer-in-Charge, Flinders Naval Depot, direct, the necessary drafting being done by the former authority.

7. D.E.M.S. Staff Officer, Sydney, will be responsible for the maintenance of the necessary "Pools" at the various ports and application for additional ratings should be made to this Officer.

8. Pay accounts of D.E.M.S. ratings will be carried in H.M.A.S. *Rushcutter*.

9. All punishments awarded to, or disciplinary action taken against, any D.E.M.S. rating serving in either a D.E.M. Ship or a Shore Establishment are to be at once communicated to D.E.M.S. Staff Officer, Sydney, who will inform H.M.A.S. *Rushcutter*.

(463/205/1750.)

321.

PERSONNEL SERVING AT NORTHERN BASES.

The periodical reports of medical examination referred to in Navy Order 43 of 1940 are no longer required, and Navy Orders 43 of 1940 and 150 of 1944 are hereby cancelled.

(527/203/749.)

322.

ADVANCEMENT TO CHIEF SHIPWRIGHT—QUALIFICATIONS.

As a temporary measure it has been decided to reduce the qualifying service for advancement to Chief Shipwright (Temporary) from six to five years.

2. The Naval Officer-in-Charge, Flinders Naval Depot, still remains the authority for these advancements, none of which are to be ante-dated to a date prior to this Order.

(349/14/43.)

(This Order will be reprinted for posting on Notice Boards.)

323.

CREMATION OF DECEASED SERVICE PERSONNEL.

With reference to Naval Financial Regulations and Instructions, Article 12, and Navy Order 553 of 1943, the Directorate of War Graves Registration is the authority to determine whether in any case cremation may be substituted for burial.

2. Consideration will be given by the Directorate to applications by next of kin for cremation in lieu of burial only when cremation facilities are available near the cemetery in which burial would normally take place.

3. Where such approval has been given, the full cost of cremation will be admitted as a charge to Public Funds.

(446/201/782.)

324.

ROCKETS, TARGET PRACTICE MARK I*, LOTS 129 AND 144—WITHDRAWAL—REPORTS.

Appended, for information and necessary action, is copy of Admiralty Fleet Order 2073/44 which has not yet been promulgated on the Australia Station:—

“Rockets, target practice, Mark I*, Lots 129 and 144, filled C.T. Brock and Co. 12/42 are to be returned to the nearest Naval armament depot at the first opportunity and others demanded in lieu. D.E.M.S. Staff Officers are to make the necessary arrangements in regard to merchant ships.

Those returned to depots abroad are to be dumped. Home depots are to report the quantities returned to D.A.S. (B.103) for disposal instructions.”

(471/208/1131.)

325.

AMMUNITION OUTFITS OF SMALL SHIPS—ARRANGEMENTS FOR PERIODICAL EXCHANGE, EXAMINATION, ETC.

It has been decided to adopt for the R.A.N., with some modifications as to classes of ships, the procedure laid down in A.F.O. 6241/43, for the periodical exchange, examination, &c., of ammunition outfits of small ships.

2. A.F.O. 6241/43 is to apply to the following classes of small ships in the R.A.N.:—

I. Outfits to be changed every two to two and a half years—

Destroyers.
Sloops.

II. Outfits to be changed every nine to twelve months—

Frigates.
A.M.S. Vessels.
Boom Vessels.
Surveying ships.
Auxiliary A/S and M/S vessels.
M.L's.

Other miscellaneous small craft.

3. Exchange of outfits should be affected during refitting period.

(408/201/2138.)

326.

AMMUNITION, ETC.—WEEKLY REPORT OF STOCK BY SHORE ESTABLISHMENTS ON FORM A.O.5Z.

The attention of all concerned is drawn to the necessity for prompt rendition of weekly stock reports rendered in accordance with Navy Order 190 of 1942.

2. Arrangements should be made to ensure that returns reach Navy Office on the Monday following the date of the return, Air Mail being used as necessary.

3. It is desired that returns should be complete up to Thursday of each week, but, if necessary, in order to comply with paragraph 2, they may be prepared earlier.

(612/202/2989.)

327.

4-IN. MARK XXIII* MOUNTINGS—ILLUMINATION OF SIGHT DIALS.

The range and deflection sight dials on all 4-in. Mark XXIII* mountings in H.M.A. Ships are to be fitted with illumination.

2. The illumination is to be by red light which is to be controlled by a separate switch and dimmer accessible to the sight setter.

3. Commanding Officers of all ships concerned are to include an item in the next supplementary defect list to cover this work.

4. Illumination for the gunsighting telescopes is not to be fitted, in view of the limited capacity of the battery.

(612/209/195.)

328.

CARRIERS AMMUNITION DOUBLE FOR O.Q.F. 4-IN. MARK XIX AND O.Q.F. 4-IN. MARK XVI*.

Carriers ammunition, double, of local design have been introduced in the R.A.N. for use with Q.F. 4-in. Mark XIX and Q.F. 4-in. Mark XVI* guns.

2. These carriers will be supplied to the following vessels in the proportion of 2 No. per gun:—

O.Q.F. 4-in. Mark XIX:—

Carriers ammunition double Q.F. 4-in. Mark IV, XII and XIX guns Mark I (A.N.).

A.M.S. Vessels.
Auxiliary Vessels.
Platypus.

O.Q.F. Mark XVI:—*

*Carriers ammunition, double Q.F. 4-in. Mark V-V*** and XV to XVII guns Mark I (A.N.).*

A.M.S. Vessels.

3. H.M.A. Ships concerned should demand double carriers required to complete from the nearest Naval Armament Depot. Ships at present carrying these carriers in excess of the above allowance are to return the surplus to the nearest Naval Armament Depot.

(490/203/946.)

329.

MICROPHOTOGRAPHIC X-RAY EXAMINATIONS.

With reference to Navy Order 120 of 1941, in order to ensure a permanent record being kept, all microphotographic X-Ray examinations required by ships and establishments are to be arranged through the Naval Recruiting Offices in the respective States, where adequate facilities exist for the arrangement and proper recording of such examinations.

2. Recruiting Officers are to take steps to communicate results of examinations to Medical Officers of the ships or establishments concerned.

3. Arrangements are also to be made by Medical Officers to ensure that the result of each examination is recorded in the respective Medical History Documents.

(527/203/608.)

330.

D.E.M.S. GUNNERY EQUIPMENT—PAINTING OF.

Gunnery equipment issued to D.E.M.S. is Government property and should be painted for preservation, demands for the necessary paint, paint brushes, &c., being forwarded to the nearest Naval Store Depot. The painting of designs on gunshields is however prohibited and D.E.M.S. Officers are to bring this instruction to the notice of Masters.

2. Attention is drawn to A.F.O. 611/44.

(490/201/1895.)

331.

SUPPLY OF CANTEEN STORES.

With reference to paragraph 2 of Navy Order 283 of 1944, it is notified for the information of all H.M.A. Ships and Establishments with canteens which are conducted on the Service System that, pending the conclusion of certain administrative arrangements now being considered by the Naval Board, the Central Canteens Control Board of the Department of the Army has been requested to defer payment of the additional rebate of 5 per cent. which will operate from 1st April, 1944.

2. A further Navy Order in the matter will be issued as soon as possible.

(427/201/864.)

By Authority: H. E. Daw, Government Printer, Melbourne.

RESTRICTED.(FOR OFFICIAL USE ONLY.)**Commonwealth Navy Orders.**

Navy Office, Melbourne,

4th July, 1944.

The following Orders, having been approved, are hereby promulgated for information and guidance, and necessary action.

By direction of the Naval Board,

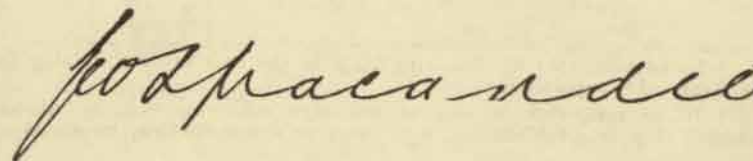

Secretary.

*The Commodore Commanding H.M.A. Squadron,
and Commanding Officers of H.M.A. Ships,
Officers in Charge of H.M.A. Naval
Establishments, and others concerned.*

TABLE OF CONTENTS.

No.	Subject.
332.	Appointments, etc., Where Date is to be Reported—Reports.
333.	Professional Examination for Warrant Writer and Warrant Supply Officer.
334.	Professional Examination for Warrant Engineer and Warrant Mechanician.
335.	Travel Concessions in New South Wales for Members of the Forces.
336.	Steel Furniture—Supply to H.M.A. Ships.
337.	Pistols Revolver—Method of Consignment.
338.	D.E.M.S. Gunnery Badges.
339.	A.M.S. Vessels—"L.L." Sweep Reel—Failure of Hand Winding Gear.
340.	"B.R. 797—Handbook on Lookouts and Service Optical Instruments" 1943—Amendments.
341.	Books and Forms.
342.	H.M.A. Victualling Depots.

C.6872/44.

332.

**APPOINTMENTS, ETC., WHERE DATE IS TO BE REPORTED—
REPORTS.**

In all cases of Naval Board appointments and of orders for demobilization and termination of appointments, where the date is to be fixed by Administrative Authorities or Commanding Officers of ships or establishments, the following detailed report is to be forwarded to Navy Office immediately the necessary action has been completed:—

“Report—Officers’ Appointments Dates

H.M.A.S.

Date

Authority.	Names.	Rank.	* Whence joined. † Reason for Discharge.	Date.

* To be completed by Receiving Ship in the case of “On Joining Date To be Reported” appointment.

† To be completed in case of discharge otherwise than by discharge to another ship or establishment, e.g., shore or demobilization, termination, &c.

Commanding Officer.

The Secretary,
Naval Board,
Navy Office,
MELBOURNE, S.C.1.

2. This instruction does not supersede the reporting of movements required by Navy Order 201 of 1943 or the rendering of Form A.S. 165, where applicable.

(409/201/3029.)

333.

**PROFESSIONAL EXAMINATION FOR WARRANT WRITER AND
WARRANT SUPPLY OFFICER.**

The next professional examination for the ranks of Warrant Writer and Warrant Supply Officer, R.A.N., will be held in December, 1944.

2. The Commanding Officers of H.M.A. Ships and Naval Establishments are requested to forward to Navy Office not later than 1st September, 1944, the names of candidates desirous of sitting for this examination. Blank returns are required.

(465/207/1244.)

(This Order will be reprinted for posting on Notice Boards.)

334.

**PROFESSIONAL EXAMINATION FOR WARRANT ENGINEER AND
WARRANT MECHANICIAN.**

The next professional examination for the ranks of Warrant Engineer and Warrant Mechanician will be held about December, 1944.

2. The Commanding Officers of H.M.A. Ships and Naval Establishments are requested to forward to Navy Office not later than 1st September, 1944, the names of candidates desirous of sitting for this examination. Blank returns are required.

3. Commanding Officers should satisfy themselves that candidates are qualified in accordance with K.R. and A.I., Article 313, as regards:—

- (a) Educational Test for Warrant Rank;
- (b) Service and Character;
- (c) Certificates;

before being allowed to take the examination.

(465/207/1243.)

(This Order will be reprinted for posting on Notice Boards.)

335.

**TRAVEL CONCESSIONS IN NEW SOUTH WALES FOR MEMBERS
OF THE FORCES.**

With reference to Navy Order 50 of 1943, paragraph 2, considerable embarrassment is being caused to transport officers and ratings at the Department of Road Transport, Sydney, by personnel entitled to free transport not being in possession of certificate indicating that they have returned from active service.

2. In future “leave passes” of ratings domiciled in New South Wales are to be endorsed as necessary and an appropriate certificate issued to officers.

3. The free passes referred to are obtainable only from the Department of Road Transport, 59 Martin-place, Sydney, on production of a suitably endorsed leave pass or certificate.

(632/202/1100.)

(This Order will be reprinted for posting on Notice Boards.)

336.

STEEL FURNITURE—SUPPLY TO H.M.A. SHIPS.

Ships which have not yet complied with paragraph 4 of Navy Order 503 of 1943 in regard to their requirements of steel furniture should forward demands to the Superintending Naval Store Officer, Sydney, as soon as possible.

(483/201/1723.)

337.

PISTOLS REVOLVER—METHOD OF CONSIGNMENT.

In view of recent losses in consignments of pistols revolver, all consignments are in future to be despatched by one of the following methods, viz. :—

Registered parcels post;
or
Passenger train;
or
Cabin freight,

and cylinders are to be packed in a separate package from the pistols

2. Attention is drawn to the necessity for care on the part of consignees to ensure that cylinders are assembled to the correct pistol. Each cylinder bears the same register number as the pistol of which it is a component.

(412/204/212.)

338.

D.E.M.S. GUNNERY BADGES.

Navy Order 93 of 1944 is to be amplified as follows:—

Paragraph 3—Amend to read:—

The issuing prices of the badges are as follows:—

Patt. 220A Acting Gunlayer D.E.M.S. red 1s. each.
Patt. 220B Acting Gunlayer D.E.M.S. blue 1s. each.
Patt. 221A Acting Seaman—Gunner D.E.M.S. red 10d. each.
Patt. 221B Acting Seaman—Gunner D.E.M.S. blue 10d. each.
Patt. 222A Letters D.E.M.S. red 4d. each.
Patt. 222B Letters D.E.M.S. blue 4d. each.

(A.F.O. 5523/1943.)

(416/201/1000.)

339.

A.M.S. VESSELS—“L.L.” SWEEP REEL—FAILURE OF HAND WINDING GEAR.

Reports received from A.M.S. Vessels indicate that the hand winding gear for the L.L. sweep reels has failed, due to the movement of the bearing support and consequent incorrect meshing of the bevel gears.

2. “Fitted” bolts are to be placed in the two bearings on the port pedestal, and the small gusset plate supporting the bearing which takes the drive shaft from the barrel is to be increased to 12 inches deep.

3. This modification is to be carried out in accordance with the appended diagram.

4. Ships concerned are to raise a Supplementary Defect List item to cover this work.

(603/247/1710.)

A.M.S. VESSELS FITTED WITH**L. L. SWEEP.****MODIFICATIONS TO SUPPORT TO SHAFT BEARING.**

NAVY OFFICE MELBOURNE	
DRG. NO. 157/546/1 FLY	
DATE: 30-5-44	DATE
DRAWN BY B.J.	30-5-44
TRACED BY B.J.	30-5-44
CHECKED BY B.J.	30-5-44
EXAMINED BY <i>[Signature]</i>	30.5.
APPROVED <i>[Signature]</i>	

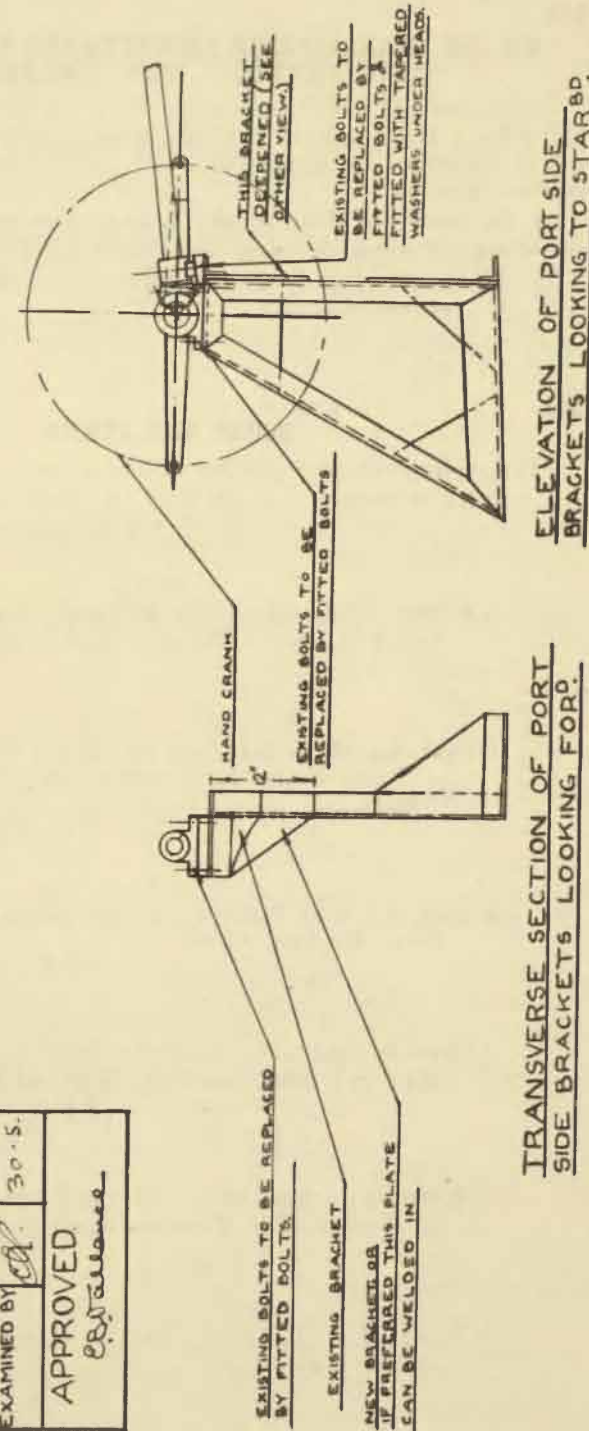

TRANSVERSE SECTION OF PORT SIDE BRACKET'S LOOKING FOR.

ELEVATION OF PORT SIDE BRACKET'S LOOKING TO STARB.

340.

"B.R. 797—HANDBOOK ON LOOKOUTS AND SERVICE OPTICAL INSTRUMENTS" (1943)—AMENDMENT.

Consequent on the introduction of the protective goggles referred to in Navy Order 459 of 1943, the procedure for searching near the sun as instructed by paragraphs 36-38 inclusive of B.R. 797 has been rendered obsolete.

2. On receipt of these goggles, a local amendment is to be inserted in the margin alongside paragraphs 36-38 as follows:—

"This procedure is not applicable when using special sun lookout protective goggles."

(612/255/44.)

341.

BOOKS AND FORMS.

The under-mentioned publications have been distributed:—

B.R.278 Series.—Torpedo Drill for Submarines.

(A.F.O's 958, 2319 and 5224/42.)

(571/202/1510.)

B.R.299A/1943.—Handbook for Signalling Equipment (other than V/S fitted in Requisitioned Ships.

(A.F.O. 234/44.)

(571/202/1687.)

Errata No. 10 to B.R. 323 and Form D.1281.—Establishment of Naval Stores for Gunnery Purposes and List of Particulars.

(A.F.O's 5790/43 and 234/44.)

(571/202/1416.)

Errata No. 2 to B.R.371.—Establishment of Naval Stores for Boom Working Vessels.

(A.F.O's 4505 and 5422/43.)

(571/202/1428.)

Addendum No. 1 to B.R.626.—Drill for 4-in., Mark XVI*, Q.F., S.A. Guns, on HA, Mark XIX, Mounting.

(A.F.O's 4767 and 5422/43.)

(571/202/1607.)

B.R.860 (1).—New Cards 8D and 17-28—Block Sketch Cards of Foreign War Vessels—Germany.

(A.F.O. 234/44.)

(571/202/1927.)

B.R.862 (Late C.B.3063 (1941).—Naval Magazine and Explosive Regulations.

(A.F.O. 4640/43.)

(571/202/1908.)

B.R.876 H Series.—(Late C.B.4096 "II" Series).

B.R.876II.—I.S.I.S. Report on Sicily.

B.R.876H (1).—Part I, History, Geography, Medical, Part II, Resources, February, 1943.

B.R.876H (1) (A).—Additions and Corrections to Part II Resources, February, 1943.

B.R.876H (1) (B).—Supplementary Additions and Corrections to Part II.

B.R.876H (2).—Additions and Corrections to Part III, Communications, February, 1943.

B.R.876H (3).—Part V (A) Coast.

B.R.876H (3) (A).—Part V (A) continued. Coast February, 1943.

B.R.876H (4).—Part V (B)—Ports, February, 1943.

B.R.876H (4) (A).—Part V (D) Inland Towns S.E. Sicily, May, 1943.

B.R.876H (6).—Parts IV and VIII Photographs.

B.R.876H (7).—Parts IV and VIII continued—Supplementary Photographs (Nos. 430-463).

B.R.876II (8).—Supplement on the Calabrian Peninsula, Part I—Topography, Climate and Medical, Part II—Communication, Part III—Coast and Ports, February, 1943.

B.R.876H (10).—Photographs.

B.R.876H (11).—Supplement on Calabrian Peninsula—Additional photographs, June, 1943.

(A.F.O. 5661/43.)

(571/202/1928.)

Addendum No. 1 to B.R.919 (F) (1).—Preliminary Pamphlet for the Gyro Rate.

(A.F.O. 889/44.)

(571/202/1910.)

Errata Nos. 12 and 13 to O.U.5365A.—Priced Vocabulary of Naval Armament Stores, Part I.

Errata Nos. 27 and 28 to O.U.5365B.—Priced Vocabulary of Naval Armament Stores, Part II.

Errata Nos. 12 and 13 to O.U.5365C.—Priced Vocabulary of Naval Armament Stores, Part III.

Errata No. 40 to O.U.5365D.—Priced Vocabulary of Naval Armament Stores, Part IV.

Errata No. 1 to O.U.5365E.—Priced Vocabulary of Naval Armament Stores, Part V.

(A.F.O's 4882/43 and 234/44.)

(571/203/2495.)

Anti-Aircraft Procedure Instructions (Aust.) Nos. 9 and 20.

Anti-Aircraft Amendments (No. 2) February, 1944.

(571/201/3921.)

D.N.C.14 (IRPL, A-8) Recommended Frequency Bands for Ships and Aircraft in the Atlantic and Pacific, April, May, June, 1944.

D.N.C.14 (IRPL, B-6) Recommended Frequency Bands for Submarines in the Pacific (Supplementary to D.N.C.14 (IRPL, A-8) April, May, June, 1944.

(571/202/1742.)

A.O.U.101 (1).—Commercial Call Signs Allocated to Allied Air Forces and Australian Acradio Stations (Short Title—"Comcall").

(571/203/2521.)

Sound Material Handbook, U.S. Navy.

(1903/2/829.)

Celluloid Aircraft Recognition Cards.

(571/201/4123.)

2. Distributing Officers are to return to the Superintending Naval Store Officer, Sydney, any copies of B.R.816 (late C.B.3070) "Handbook for the 2-inch Rocket Mark II (P) Pillar Box Mounting" which can be spared. Replacement will be made on receipt of a further supply from London.

(571/202/1772.)

3. The under-mentioned forms have been revised. Supply will be effected on demand, when stock of the existing form is exhausted.

A.S.1040Z.—Memorandum forwarding and Receipt for Amounts due to Officers and men on leave or in Hospital, &c.

(480/202/4601.)

A.S.1048.—Daily abstract of Clothing issued on repayment.

(480/202/4604.)

342.

H.M.A. NAVAL VICTUALLING DEPOTS.

It has been decided to follow Admiralty procedure in regard to designation of Victualling Establishments set up since the commencement of hostilities, namely at Brisbane, Fremantle, Port Melbourne, Cairns, and Townsville. These Establishments will in future be designated H.M.A. Naval Victualling Depots and referred to as such in all official communications.

2. A Victualling Store Officer is in charge of the Naval Victualling Depot at both Brisbane and Fremantle, and correspondence should be addressed to that Officer as heretofore, but at the other ports referred to all communications should be addressed to the Officer-in-Charge of the Depot concerned.

(404/201/661.)

By Authority: H. E. DAW, Government Printer, Melbourne.

RESTRICTED.

(FOR OFFICIAL USE ONLY.)

Commonwealth Navy Orders.

Navy Office, Melbourne,

11th July, 1944

The following Orders, having been approved, are hereby promulgated for information and guidance and necessary action.

By direction of the Naval Board,

J. O. Macandee
Secretary.

*The Commodore Commanding H.M.A. Squadron,
and Commanding Officers of H.M.A. Ships,
Officers in Charge of H.M.A. Naval
Establishments, and others concerned.*

TABLE OF CONTENTS.

No.	Subject.
343.	National Security (General) Regulations—Order Made Thereunder—Navigation and Anchor Lights Order (No. 3).
344.	Examination of Engine Room Ratings, March, 1944—Results.
345.	Classification of Night Vision by A.R.L. Adaptometer (Mark III).
346.	Mental Disorder—Certification of Members of R.A.N. Suffering from.
347.	Form A.M.301z—Medical Status of Personnel Recommended to be Invalided. Introduction of.
348.	Concession Railway Fares of Service Personnel Travelling in Uniform and Paying Their own Fares.
349.	20 mm Oerlikon Guns—Locking Barrels.
350.	Guns—Oerlikon 29 mm Mk. II and IV—Collapse of Barrel Springs, Mark I.
351.	Guns Q.F. 3-in. 20 cwt., Mk. I, IB-IE, Pins Axis Breech Mechanism Lever Catch Mk. I to be Replaced by Mk. II.
352.	Guns Machine Lewis .303-in. I—Conversion of Mark IV Sights (100 knots) to Mark V (200 knots) and Fitting of Mk. III Butt Plate.
353.	Magnetic Compass—Effect of Telephones on.
354.	Wooden Furniture—Replacement by Steel in Cruisers, Destroyers, A.M.S. Vessels, and "Warrego" and "Swan."
355.	Penicillin.
356.	Uniform and Clothing for Ratings in Military Detention Barracks.
357.	Sugar—Consumption Outside Territorial Waters.
358.	Books and Forms.
359.	Books and Forms.

343.

NATIONAL SECURITY (GENERAL) REGULATIONS—ORDER MADE THEREUNDER.

The following is promulgated for information:—

(Commonwealth Gazette, No. 123, dated 22nd June, 1944.)

COMMONWEALTH OF AUSTRALIA.

NATIONAL SECURITY (GENERAL) REGULATIONS.

Navigation and Anchor Lights Order (No. 3).

Whereas by Instrument of Delegation dated the twenty-first day of September, 1943, and published in the *Gazette* on the first day of October, 1943, the Minister delegated, *inter alia*, the powers and functions conferred upon him by regulation 45 of the National Security (General) Regulations to every officer who shall at any time during the continuance of such delegation be holding or performing the duties of the office of Chief of the Naval Staff:

Now therefore, I, Guy Charles Cecil Royle, Chief of the Naval Staff, acting in pursuance of the powers conferred by the said regulation and delegation, do hereby order as follows:—

Citation.

1. This Order may be cited as the Navigation and Anchor Lights Order (No. 3).

Navigation Lights.

2. Paragraph 4 of the Navigation and Anchor Lights Order is amended by omitting sub-paragraph (6) and inserting the following paragraph in its stead:—

“(6). A vessel shall exhibit dimmed navigation lights within the following areas and passages:—

- (a) In Bass Strait between the meridians of 142 deg. 30 min. E. and 148 deg. 00 min. E. when north of the parallel 39 deg. 30 min. S.;
- (b) in Banks Strait;
- (c) in St. Vincent and Spencer Gulfs when north of the parallel 35 deg. 10 min. S.;
- (d) inside the Great Barrier Reef between the parallels of 10 deg. 35 min. S. and 24 deg. 30 min. S.; and
- (e) in the New Guinea area when proceeding coast-wise between Milne Bay and Cape Ward Hunt, and between Milne Bay and Goodenough Island”.

Dated this fifth day of June, 1944.

GUY ROYLE,
Chief of the Naval Staff.

344.

EXAMINATION OF ENGINE ROOM RATINGS, MARCH, 1944—RESULTS.

Name.	Present Rating.	Application Received From.	Result.	
<i>E.R.A. for C.E.R.A. Mechanician I. for Chief Mechanician.</i>				
D/MX47950	Blaylock, J. ..	E.R.A. 2 ..	<i>Ariadne</i> ..	Passed Sat.
23509	Boyd, J. ..	E.R.A. 3 ..	<i>Hobart</i> ..	Passed Sat.
S/4251	Buntine, H. D. ..	E.R.A. 3 ..	<i>Magnetic</i> ..	Passed Sat.
20403	Greaves, L. M. ..	Mechn. 1 ..	<i>Australia</i> ..	Passed Sat.
S/344	Greig, R. J. ..	E.R.A. 3 ..	<i>Mailland</i> (<i>Strahan</i>)	Passed Sat.
PM/1797	Henshall, W. M. ..	E.R.A. 3 ..	<i>Benalla</i> ..	Passed Sat.
19444	Linaker, R. O. ..	Mechn. 1 ..	<i>Moreton</i> (<i>Kianga</i>)	Passed Supr.
22698	McGregor, G. A. ..	E.R.A. 3 ..	<i>Hobart</i> ..	Passed Sat.
23279	Purvis, J. C. ..	E.R.A. 3 ..	<i>Australia</i> ..	Passed Sat.
19946	Rissel, C. E. ..	Mechn. 1 ..	<i>Cowra</i> ..	Passed Sat.
23933	Rudge, W. G. ..	E.R.A. 3 ..	<i>Whyalla</i> ..	Passed Supr.
23761	Slatter, H. G. ..	E.R.A. 3 ..	<i>Shropshire</i> ..	Passed Sat.
23765	Stacey, N. H. ..	E.R.A. 3 ..	<i>Bendigo</i> ..	Passed Sat.
20046	Watts, F. N. ..	Mechn. 1 ..	<i>Shropshire</i> ..	Passed Sat.

E.R.A.A./4th Class for Confirmation. Mechanician II. for Mechanician I.

PM/446	Adams, L. W. ..	E.R.A.A/4th	<i>Hobart</i> ..	Passed Sat.
F/4146	Allan, A. T. ..	E.R.A.A/4th	<i>Moreton (Tongkol)</i>	Passed Supr.
PM/5765	Ballingall, D. A. S. ..	E.R.A.A/4th	<i>Colac</i> ..	Passed Sat.
F/4036	Beard, G. H. ..	E.R.A.A/4th	<i>Penguin</i> ..	Passed Supr.
PM/5760	Bellemey, A. ..	E.R.A.A/4th	<i>Adelaide</i> ..	Passed Sat.
PM/44*0	Boyes, B. L. ..	E.R.A.A/4th	<i>Swan</i> ..	Passed Sat.
20532	Bradshaw, W. E. R. ..	Mechn. II.	<i>Adelaide</i> ..	Passed Supr.
F/5022	Casas, P. E. ..	E.R.A.A/4th (M)	<i>Kanimbla</i> ..	Passed Sat.
F/2249	Clark, F. D. ..	E.R.A.A/4th	<i>Lonsdale</i> (<i>Whang Pu</i>)	Passed Supr.
S/3529	Coomber, R. N. ..	E.R.A.A/4th (M)	<i>Kanimbla</i> ..	Passed Sat.
H/1766	Dale, S. T. J. ..	E.R.A.A/4th (M)	<i>Kanimbla</i> ..	Passed Supr.
F/3995	Davidson, W. T. ..	E.R.A.A/4th	<i>Platypus</i> ..	Passed Supr.
PM/6202	Eastmure, B. K. ..	E.R.A.A/4th	<i>Adelaide</i> ..	Passed Exceptnl.
PM/6075	Emerson, F. ..	E.R.A.A/4th	<i>Lonsdale (Orara)</i>	Passed Sat.
F/4041	Evans, B. P. ..	E.R.A.A/4th	<i>Shropshire</i> ..	Passed Supr.
S/3171	Forrest, E. C. ..	E.R.A.A/4th	<i>Platypus</i> ..	Passed Sat.
PA/4014	Freeman, E. G. ..	E.R.A.A/4th	<i>Shropshire</i> ..	Passed Sat.
S/5752	Gates, W. A. F. ..	E.R.A.A/4th	<i>Platypus (T.I.)</i>	Passed Supr.
S/6963	Gilshenen, S. G. ..	E.R.A.A/4th	<i>Adelaide</i> ..	Passed Supr.
B/4312	Gordon, J. S. ..	E.R.A.A/4th	<i>Ballarat</i> ..	Passed Supr.
PM/5946	Graham, W. E. ..	E.R.A.A/4th	<i>Adelaide</i> ..	Passed Sat.
24645	Gregg, D. A. ..	E.R.A.A/4th	<i>Mildura</i> ..	Passed Sat.
PA/2860	Gunner, C. R. ..	E.R.A.A/4th	<i>Shropshire</i> ..	Passed Supr.
20606	Hall, G. K. ..	Mechn. II.	<i>Adelaide</i> ..	Passed Exceptnl.
B/4630	Hawkins, H. P. ..	E.R.A.A/4th	<i>Kalgoorlie</i>	Passed Supr.
21158	Hawkins, R. ..	Mechn. II.	<i>Penguin</i> ..	Passed Exceptnl.
PM/5564	Heading, B. T. ..	E.R.A.A/4th	<i>Whyalla</i> ..	Passed Supr.
S/8950	Heathcote, R. H. G. ..	E.R.A.A/4th (M)	<i>Kanimbla</i> ..	Passed Sat.
PM/5945	Hogan, V. J. ..	E.R.A.A/4th	<i>Lonsdale (Orara)</i>	Passed Sat.
PM/6071	Howden, W. R. ..	E.R.A.A/4th	<i>Boom Defence,</i> <i>Darwin</i>	Passed Sat.
S/6965	Hudson, H. E. R. ..	E.R.A.A/4th	<i>Boom Defence,</i> <i>Darwin</i>	Passed Sat.

7. Ratings whose standard of night vision is shown as "BAD" by the Adaptometer tests are not to be employed on night look-outs. As the presence of ratings with defective night vision would constitute a handicap in small ships with limited personnel, they are to be regarded for drafting purposes as fit for large ships only, and Commanding Officers of small ships should request reliefs for any rating whose category is classed as "BAD."

8. Navy Orders 85 of 1941 and 357 of 1942 are hereby cancelled.
(527/203/678.)

346.

MENTAL DISORDER—CERTIFICATION OF MEMBERS OF R.A.N. SUFFERING FROM.

With reference to regulation 47 of the National Security (Supplementary) Regulations—"Members of the Forces suffering from Mental Disorder" (*vide* Navy Order 435 of 1943), the Director of Naval Medical Services has authorized Naval Medical Officers at present holding the following appointments to act on his behalf:—

Principal Medical Officer, Naval Hospital, Sydney, New South Wales.

Senior Medical Officer, Flinders Naval Depot, Victoria.

Senior Medical Officer, H.M.A.S. *Lonsdale*.

Senior Medical Officer, H.M.A.S. *Moreton*.

Senior Medical Officer, H.M.A.S. *Leeuwin*.

District Naval Medical Officer, South Australia.

District Naval Medical Officer, Tasmania.

2. This authority is a personal delegation, and remains in force only so long as the officer to whom it is issued continues to hold the particular appointment indicated above which he is at present holding. Upon relief, a successor will be appointed personally.

3. In the event of its being considered that a member of the Forces requires institutional treatment for a mental condition as specified in regulation 47 of the National Security (Supplementary) Regulations, action is to be taken to refer the case to one of the medical officers empowered under the regulation, for the requisite certification and authority for admission to an institution established for the treatment of mental disorders.

4. Navy Order 2 of 1943 is hereby cancelled.
(584/201/620.)

347.

FORM A.M.301z—MEDICAL STATUS OF PERSONNEL RECOMMENDED TO BE INVALIDED, INTRODUCTION OF.

The above-mentioned form has been established to facilitate compliance with Navy Order 336 of 1943. Parts 1 to 7 inclusive are to be completed by the Senior Medical Officer of the Final Medical Board of Survey or his deputy, and lodged for requisite action with the Rehabilitation Officer of the Depot in which the survey takes place.

2. The Rehabilitation Officer of the member's home depot is to communicate verbally to the invalided member the information contained in Parts 4, 5 and 6 of Form A.M.301z.

3. First supply of this form will be issued by the Medical and Dental Store Officer, Sydney, without demand, to the Senior Medical Officers, H.M.A. Ships *Moreton*, *Penguin*, *Rushcutter*, *Kuttabul*, *Lonsdale*, *Cerberus*, *Torrens*, *Leeuwin*, and *Huon*.

(480/201/3357.)

348.

CONCESSION RAILWAY FARES FOR SERVICE PERSONNEL TRAVELLING IN UNIFORM AND PAYING THEIR OWN FARES.

The Commonwealth Department of Transport Pamphlet No. 2, issued in January, 1942, set out the conditions under which concession fares would be granted to personnel travelling in uniform and paying their own fares.

2. The procedure for obtaining this concession in New South Wales and Queensland has been amended, and personnel travelling on leave intrastate and interstate and paying own fares, will in future obtain tickets on presentation of Railway Travel Certificate (A.A.F. T.12).

3. *Railway Travel Certificate* (A.A.F. T.12).

(a) Personnel desiring concession rates on the railway system of Queensland or the non-suburban railway system of New South Wales should, if serving in ships or establishments based in either of these States, obtain travel certificate/s from the unit before proceeding on leave; or, if on leave in New South Wales or Queensland from other States, then from the nearest Rail Transport Officer.

(b) Railway Travel Certificates (A.A.F. T.12) are printed in books containing 50 forms in duplicate. While not in use, the books are to be kept under lock and key.

(c) A Railway Travel Certificate (A.A.F. T.12) will be issued only by an Officer or Rail Transport Officer.

(d) One form is required for each ticket the member wishes to purchase.

(e) Before issuing a Railway Travel Certificate (A.A.F. T.12), the Officer or Rail Transport Officer will—

(i) inspect the member's leave pass; and

(ii) satisfy himself, as far as practicable, that the member is validly on leave, and is entitled to make the journey for which the certificate is requested.

(f) The Officer or Rail Transport Officer issuing a Railway Travel Certificate (A.A.F. T.12) will—

(i) complete the Certificate by entering thereon particulars of the member, the times within which the travel is authorized, and the destination to which the member desires to proceed;

- (ii) sign and date the Certificate over the imprint of a rubber stamp, indicating the issuing authority; and
- (iii) ensure that all entries are legibly written in ink or in indelible pencil and that a clear and legible carbon copy is made on the duplicate.

(g) The duplicate copy of the Certificate is to be left in the book, which, when complete, is to be endorsed on the cover with the designation of the issuing authority and the period covered. Completed books when so endorsed are to be forwarded to the issuing authority.

4. Naval Officers-in-Charge, Sydney and Brisbane, are to act as the central authority for the distribution of these books of forms, which are to be obtained from—

New South Wales.—New South Wales L. of C. Area,
Stationery Depot,
corner of Mary and Reservoir streets,
Sydney.

Queensland.—Queensland L. of C. Area,
Stationery Depot,
Stanley-street,
South Brisbane.

(632/201/164.)

(This Order will be reprinted for posting on Notice Boards.)

349.

20 MM OERLIKON GUNS—LOCKING OF BARRELS.

The instructions contained in Navy Order 179 of 1944 are now cancelled.

2. Further instructions will be promulgated later.

(490/212/987.)

350.

GUNS—OERLIKON 20 MM MKS. II AND IV—COLLAPSE OF BARREL SPRINGS, MARK I.

The reduction in allowance of spare barrel springs referred to in paragraph 3 of Admiralty Fleet Order 575/44 will not apply to H.M.A. Ships.

(490/212/1106.)

351.

GUNS Q.F. 3-IN. 20 CWT., MKS. I, IB-IE, PINS AXIS BREECH MECHANISM LEVER CATCH MK. I TO BE REPLACED BY MK. II.

The modification referred to in A.F.O. 692/44 is also applicable to Q.F. 3-in. 20 cwt. Mark I.B. (Land Service) guns, a few of which have been taken over from the Army for use afloat.

(490/206/94.)

352.

GUNS MACHINE LEWIS 303-IN. I—CONVERSION OF MARK IV SIGHTS (100 KNOTS) TO MK. V (200 KNOTS) AND FITTING OF MK. III BUTT PLATE.

The modification referred to in Admiralty Fleet Order 3556/43 will be carried out only in respect of Guns machine Lewis .303-in. mounted in H.M.A. Ships as A.A. weapons.

2. R.A.N. Armament Depots other than Sydney are to demand the necessary conversion parts from the Superintending Armament Supply Officer, Sydney.

(490/212/975.)

353.

MAGNETIC COMPASSES—EFFECT OF TELEPHONES ON.

Recently in one of H.M.A. Ships the magnetic compass was affected up to 22 degrees, due to the fact that the telephone from the radar office had a lead sufficiently long to permit its reaching close thereto when in use.

2. Attention is therefore drawn to the provisions of A.F.O. 4532/42, which reads as follows:—

“4532—Magnetic Compasses—Effect of Telephones on.
(C.D. 556/42—17.9.1942.)

Attention was called in various Fleet Orders to the fact that the hand and head sets of telephones contain strong magnets which are capable of causing large errors in the magnetic compass if brought close to it. It has been laid down that telephones are not to be brought closer to the compass than 2 to 4 feet according to type.

2. It appears, however, that although the telephone may have been safely positioned when in its stowage position, it may often have sufficient length of lead to allow it to be brought much closer to the compass than is allowed, and this possibility does not seem to have been always appreciated.

3. Commanding Officers should take steps to see that the leads on telephones are not long enough to allow the actual telephone to be brought too near to the compass. But if for some reason it is not possible to do this, officers and ratings liable to use the telephone should be cautioned not to bring it close to the compass.

4. The safe distances for the various types of telephone are given below. It has occurred, however, that occasionally a telephone has been found to affect the compass at much greater distances, and the possibility of this occurring should be investigated wherever telephones are fitted near the compass:—

Telephone.	Safe distance.
Loudaphone headsets 5 feet
Brown's headphones, Pattern 4968 5 feet
South power and warning telephone 4 feet
Other types 3 feet "

(603/290/820.)

354.

WOODEN FURNITURE—REPLACEMENT BY STEEL IN CRUISERS. DESTROYERS. A.M.S. VESSELS, "WARREGO" AND "SWAN."

A.F.O. 5395/43—“Furniture—Carcase Steel” and A.F.O. 5396/43—“Furniture—Tubular Steel”—are to apply in principle to H.M.A. Ships.

2. The designs of steel furniture have been standardized, and particulars of the types which have been approved for installation in H.M.A. Ships in place of wooden articles are shown in the following drawings, copies of which have been forwarded direct to the ships concerned:—

Navy Office Drawing 0/1256.—Designs suitable for Cruisers and Tribal Class Destroyers.

Navy Office Drawing 3620.—Designs suitable for *Stuart*, *Vendetta*, *Warrego*, *Swan*, and A.M.S. Vessels.

Priority of supply will be given to the requirements of H.M.A. Ships, *Australia*, *Shropshire*, *Hobart*, *Arunta*, and *Warramunga*.

3. Commanding officers of ships mentioned in paragraph 2 are to include an item, classification “A,” to cover the work involved, in their next list of Alterations and Additions. The item is to be forwarded in three parts:—

Part 1.—To fit standard articles of steel furniture, as shown in the above-mentioned drawings, which are Sea Stores.

Part 2.—To supply and fit standard articles of steel furniture as shown in the above-mentioned drawings, which are not Sea Stores.

Part 3.—To supply and fit other items not Sea Stores and not specifically covered by the above-mentioned drawings, which it is considered essential should be of steel. Detailed particulars and drawings of such items should be furnished.

4. Demands for the Sea Store items should be forwarded to Superintending Naval Store Officer, Sydney, in accordance with the Sea Store Establishments, accompanied by a statement showing the pattern numbers, descriptions and quantities of wooden furniture which are on board, and will be returned when replacement by steel furniture can be effected.

5. Navy Order 503 of 1943 is hereby cancelled.

(483/201/1723.)

355.

PENICILLIN.

Penicillin is now available for use in all ships carrying a medical officer.

2. Supplies in the first instance will be made without demand according to scale. Further supplies can be obtained from a Naval Medical Store or the Deputy Director of Medical Services (Army). Local Command.

3. Depots and Establishments should make their demands to the Deputy Director of Medical Services (Army), Local Command or a Naval Medical Store, whichever is more convenient. For these Establishments there is no scale of issue, and demands should be made as required.

4. Instructions for its use and mode of administration have been issued in R.A.N. Medical Technical Instruction No. 19.

5. The drug should be stored at a temperature of 5° Centigrade when received.

6. Scale.—Destroyers, Sloops, and other ships carrying one medical officer—Penicillin, 1,000,000 units.

All Cruisers and L.S.F's.—Penicillin, 5,000,000 units.

(612/213/2712.)

356.

UNIFORM AND CLOTHING FOR RATINGS IN MILITARY DETENTION BARRACKS.

With reference to Navy Orders 421 of 1942, 5 and 487 of 1943, when ratings are sent to Military Detention Barracks they are to be in possession of the following items of kit:—

<i>Class II.</i>	<i>Class III.</i>	<i>Classes II and III.</i>
1 Serge Suit	1 Seamen's Serge Suit	1 pr. Boots
2 Flannels	S.B.	2 Towels
1 Jersey (in winter)	2 White Shirts	2 prs. Socks
1 Blue Jean Collar	4 Semi-stiff Collars	2 prs. Drawers or
1 Black Scarf	1 Black Tie	Shorts
1 Lanyard	1 Lightweight Cap	1 Hair Brush
1 Cap	1 Cap Cover	1 Tooth Brush
1 Cap Ribbon	1 Cap Badge	1 Shaving Brush
		1 Razor
		1 Set Boot Brushes,
		Boot Polish
		1 Housewife
		3 lb. Soap
		1 Combination Suit
		2 Singlets

Bedding is not to accompany ratings, as it is provided by the Military Authorities.

2. Articles of kit deficient or requiring replacement during detention are in all cases to be issued on repayment, the amount involved being signed for by the rating on a casual payment sheet and charged against kit upkeep allowance in his ledger account. Attention is drawn to the provisions of Navy Order 549 of 1943, concerning the recovery of articles of uniform of a definite Service character in the event of the rating undergoing sentence being ultimately discharged.

3. Articles 57 and 58 of Naval Financial Regulations and Instructions, also Article 481, clause 18, of Consolidated Orders and Regulations, are to be appropriately noted in regard to the above altered procedure.

(516/201/653.)

357.

SUGAR—CONSUMPTION OUTSIDE TERRITORIAL WATERS.

Navy Order 214 of 1942, which requires Commanding Officers of seagoing ships to forward to the Victualling Store Officer, Sydney, monthly certificates showing the quantities of sugar and golden syrup consumed outside Australian territorial waters, is cancelled.

2. In substitution thereof, a certificate in the following form is to be forwarded by Commanding Officers to the Director of Victualling, Navy Office, immediately after the end of each month, commencing July, 1944, in respect of sugar only which is received from Australian sources:—

“ I certify that, of the total quantity of lb. sugar received from Australian sources and issued in H.M.A.S. during the month of a quantity of approximately lb. was consumed outside Australian territorial waters.”

3. As there is a difference of approximately £14 per ton between the home consumption and export prices of sugar, it is important that Commanding Officers of all sea-going ships, including tenders, ensure that this certificate is carefully completed, and that the quantities shown as consumed outside territorial waters are carefully calculated in order that replacement at export rates may be arranged without difficulty or delay.

4. Nil returns are to be forwarded, where applicable.
(668/213/49.)

358.

BOOKS AND FORMS.

The under-mentioned form has been introduced for use in the R.A.N., and supply will be effected, on demand, by the Superintending Naval Store Officer, Sydney:—

S.1423G.—Spare sheets for Naval Armament and Torpedo Stores Ledger.

(A.F.O. 1012/43.)
(480/202/4508.)

2. The under-mentioned forms have been introduced for use in the R.A.N., and supply will be effected, without demand, by the Superintending Naval Store Officer, Sydney:—

F.A.30z (R.A.N.).—Naval Armament Store Ledger for use in vessels armed with machine guns or below.

Printed Headings covering spares and appurtenances, &c., to be used to cover existing blank column for headings at the top of pages 7 to 40 inclusive of Form F.A.30z (R.A.N.) when required in respect of the under-mentioned guns:—

Guns, machine, Oerlikon, 20 mm.
" " Vickers, .303-in.
" " Hotchkiss, .303-in.
" sub-machine, Owen, 9 mm.
" " Thompson, .45-in.

3. The use of Form S.1423G will be minimized by the introduction of Form F.A.30z and printed headings.

(480/201/3189.)

359.

BOOKS AND FORMS.

With reference to Navy Order 78 of 1944, the reference number of the publication “Theory Notes for Radio Mechanics” should be amended to read “A.P. 3023.”

(571/201/4008.)

By Authority: H. E. DAW, Government Printer, Melbourne.

RESTRICTED.(FOR OFFICIAL USE ONLY.)**Commonwealth Navy Orders.**

Navy Office, Melbourne,

18th July, 1944.

The following Orders, having been approved, are hereby promulgated for information and guidance, and necessary action.

By direction of the Naval Board,

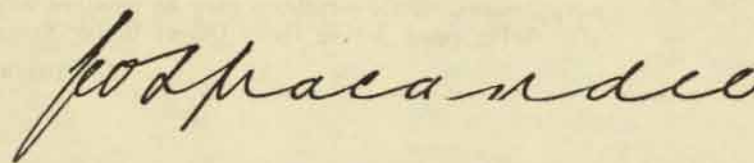

Secretary.

*The Commodore Commanding H.M.A. Squadron
and Commanding Officers of H.M.A. Shvps,
Officers in Charge of H.M.A. Naval
Establishments, and others concerned.*

TABLE OF CONTENTS.

No.	Subject.
360.	Radio Mechanic Branch—Advancement to Petty Officer.
361.	Special Rate of Pay for Warrant Officers.
362.	Replacements for Electrical Equipment in Motor Launches.
363.	India-United Kingdom Air Mail.
364.	Airgraphs.
	C.7446/44.

360.

RADIO MECHANIC BRANCH—ADVANCEMENT TO PETTY OFFICER.

Navy Order 414 of 1943 is to be amended by omitting paragraph 10 and substituting the following paragraph in its stead:—

“10. *Advancement.*—After one year's combined service as Leading Radio Mechanic and Leading Wireless Mechanic, advancement to Acting Petty Officer Radio Mechanic may be made by the Commanding Officer if satisfied that the man is suitable for the Acting Petty Officer rate. In any case in which a man is not considered suitable for Acting Petty Officer rating, the facts are to be reported to the Naval Board in order that his retention in the Branch may be considered. A full statement of the circumstances is to be made, giving reasons which may exist for his incompetence, or any details as to misconduct. An Acting Petty Officer Radio Mechanic will be eligible for advancement to Petty Officer Radio Mechanic on completing twelve months' seniority in the Acting Rating, provided that his Commanding Officer considers him satisfactory, and that he holds a certificate signed by a qualified Signal or Radar Officer that he is technically competent for advancement. This certificate may be obtained any time after being rated Acting Petty Officer Radio Mechanic.”

(568/202/993.)

361.

SPECIAL RATE OF PAY FOR WARRANT OFFICERS.

With reference to Naval Financial Regulations and Instructions, Article 24, clause 3, regarding the fixation in certain cases of a special rate of pay on promotion to Warrant Rank, the conditions governing similar cases in the Royal Navy restrict the payment of a special rate to Warrant Officers who immediately prior to promotion thereto were in receipt of marriage allowance.

2. It has now been decided with effect from 1st January, 1944, to extend eligibility for the grant of a special rate on promotion, where appropriate, to all R.A.N. Warrant Officers.

3. In the case of such officers at present serving who, but for the restriction referred to in paragraph 1, would have been eligible for payment of a special rate of pay, the necessary adjustments as from 1st January, 1944, will be communicated from Navy Office.

(556/218/946.)

362.

REPLACEMENTS FOR ELECTRICAL EQUIPMENT IN MOTOR LAUNCHES.

Most of the Motor Launches in the R.A.N. are fitted with electrical equipment manufactured in the United Kingdom or Australia. As some of this equipment is not interchangeable, care should be taken to ensure that demands for replacements indicate whether the items required are of British or Australian manufacture.

(612/217/1483.)

363.

INDIA—UNITED KINGDOM AIR MAIL.

Arrangements have been made for the carriage of Australian Air Mails over the route from Ceylon to the United Kingdom via Egypt and Gibraltar.

2. Until air service facilities across the Indian Ocean are available, the air mails from Australia will be forwarded by sea to connect with the air service from India.

3. A flat rate of 1s. 6d. per half-ounce for letters and 9d. for post-cards will be charged for correspondence sent by the new route via India. No routing superscription on the envelope is required, but each article must bear the airmail label or be prominently endorsed “By Air Mail”. The weight limit of 2 oz. applicable to the U.S. Air Mail route does not apply to mail sent by the new route.

4. The present air mail service, viz., by sea to the United States and thence by air to the United Kingdom, will for the time being continue to be used for mails bearing the appropriate fee (2s. 1d. per half-ounce), and superscribed for transmission via the United States of America.

(563/201/1512.)

(This Order will be reprinted for posting on Notice Boards.)

364.

AIRGRAPHS.

Airgraph letters without fees affixed have recently been received from personnel of H.M.A. ships in the ships' mails.

2. No provision exists for the acceptance of free airgraphs, and the Post Office has advised that any such letters received not bearing the appropriate postage will not be transmitted by the airgraph service, but will be returned to the senders by ordinary post.

(443/201/1326.)

(This Order will be reprinted for posting on Notice Boards.)

RESTRICTED.(FOR OFFICIAL USE ONLY.)

Commonwealth Navy Orders.

Navy Office, Melbourne,
25th July, 1944.

The following Orders, having been approved, are hereby promulgated for information and guidance, and necessary action.

By direction of the Naval Board,

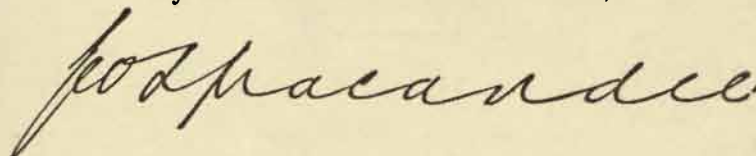

Secretary.

*The Commodore Commanding H.M.A. Squadron,
and Commanding Officers of H.M.A. Ships,
Officers in Charge of H.M.A. Naval
Establishments, and others concerned.*

TABLE OF CONTENTS.

No.	Subject.
365.	Ian Macdonald Memorial Prize.
366.	Temporary Commissions—Accountant Branch Ratings.
367.	Recommendations for Non-Substantive Rates.
368.	Meals for R.A.N. Personnel Travelling by Troop Train.
369.	Reduction of Fire and Smoke Risk in H.M.A. Ships—Types of Paint to be used for Interior Painting.
370.	A.M.S. Vessels—Modification to Firemain at Station 54.
371.	Propellers and Tailshafts—Base Spares.
372.	Gun Mounting 4-in. Mark XXIII and XXIII*—Elevation Buffer Stop—Replacement of Spring by Distance Piece.
373.	Gun Mounting 4-in. Mark XXIII and XXIII*—Lower Elevation Gear Box—Fitting of Leather Washer.
374.	Gun Mounting 4-in. Mark XXIII and XXIII*—Firing Gear—Modification to Catch Piece.
375.	Ordnance Q.F. 40 mm. Bofors—Liquid in Recoil Buffers.
376.	Sperry Mark XIV Mod. 1 Gyro Compass—Oiling of Upper Vertical Guide Bearing.
377.	Sperry Mark XIV Gyro Compass—Repeater Bezel Screws.
378.	Sperry Mark XIV Mod. 1—Gyro Compass—Mercury Ballistic Caps.
379.	Sperry Mark XIV. Gyro Compass—Condenses—Follow Up Circuit.
380.	Ammunition—Cartridges, 40 mm. Bofors H.E. Ammunition of British Land Service Manufacture Fitted with Primers No. 18—Withdrawal from Naval Service—Report.
381.	Depth Charge Throwers, Mark IV—Securing Strop—Supply of Spare Wire Spans.
382.	Respirators, Anti-Gas—Painting of Haversacks.
383.	Naval Armament Store Accounts—H.M.A. Ships, &c.—Consumable Stores.
384.	Accounting for Machinery, Machine Tools, &c., Supplied for Naval Workshops.
385.	Accounts for Provisions Supplied to Tenders When Absent from Parent Ship.
386.	Bedding for W.R.A.N.S.
387.	King's Regulations and Admiralty Instructions—Reprint.
388.	Books and Forms.
389.	Corrigendum.

365.

IAN MACDONALD MEMORIAL PRIZE.

The Ian Macdonald Memorial Prize for 1943 has been awarded to Sub-Lieutenant J. D. Goble, R.A.N.

2. Sub-Lieutenant G. H. McIntosh, R.A.N., also gained first class certificate in signals.

(635/201/1554.)

366.

TEMPORARY COMMISSIONS—ACCOUNTANT BRANCH RATINGS.

The following revised arrangements for the selection and training of R.A.N.R. ratings for Temporary Commissions in the Accountant Branch of the Royal Australian Naval Reserve have been approved.

Writers, Supply Ratings, Cooks and Stewards are eligible and may be recommended for the Accountant Officers' Training Course if they possess the necessary educational and other qualifications. A Cook or Steward, if selected for the course, will be transferred to the Writer or Supply Branch and not revert to his original rating in the event of failure to obtain promotion. A candidate must be qualified educationally up to at least one of the following *standards*. (He need not necessarily have obtained the certificate.)

New South Wales—Intermediate Certificate or Sub-Leaving Certificate.

Victoria—Intermediate Certificate.

Queensland—Junior Certificate Examination. Queensland University.

South Australia—Intermediate Certificate.

Western Australia—Junior Certificate.

Tasmania—Public Schools Certificate or Intermediate Certificate standard.

2. On commencement of Form C.W.1, a Form C.W.1A should immediately be prepared and duplicates of both forms forwarded to the Naval Officer-in-Charge, Flinders Naval Depot. The original Form C.W.1 and Form C.W.1A should be retained, and should follow the rating concerned when drafted to a new ship or establishment. The normal age limit for commencement of Form C.W.1 is twenty-five years, but, in special cases, candidates up to the age of thirty-five years may be recommended.

3. Ships and outlying stations should report the commencement of a Form C.W.1 to the Administrative Authority concerned, who will convene a local Selection Board during January, May and September each year to interview Accountant Branch C.W.1. candidates serving under his command. Administrative Authorities will forward to the

Naval Officer-in-Charge, Flinders Naval Depot, by 31st January, 31st May and 30th September each year, a return of candidates, in order of merit, accompanied by an up-to-date Form C.W.1A for each candidate. The Administrative Authorities concerned are:—

The Rear-Admiral Commanding, H.M.A. Squadron;
Naval Officers-in-Charge of Base Ports.

Ships not under the administration of one of these Authorities are to forward returns of candidates and Forms C.W.1A direct to the Naval Officer-in-Charge, Flinders Naval Depot.

To assist in maintaining a uniform standard with regard to selection and order of merit, advantage should be taken, when possible, of the visit of the Inspecting Accountant Officer to the various Base Ports to interview candidates who are in view for inclusion in the next periodical return.

On receipt of these returns, the Naval Officer-in-Charge, Flinders Naval Depot, will select up to five Writers and four Supply Ratings for the next course, according to requirements.

4. Three Accountant Officers' Training Courses are held each year, commencing the first week in January, May and September; they are of sixteen weeks' duration and comprise—

4 weeks—Ship's Office work.

4 weeks—Captain's Office work.

6 weeks—Stores and Victualling.

2 weeks—Revision, Examinations and Boards.

5. Accountant Branch Ratings recommended, after qualification in the Accountant Officers' Training Course, will be promoted to Acting Paymaster Sub-Lieutenant (on probation) R.A.N.R. if 19½ years of age or over. The appointment of Paymaster Midshipman, R.A.N.R. is temporarily suspended.

6. Writers or Supply Assistants not selected for Commissions will, if recommended by the Naval Officer-in-Charge, Flinders Naval Depot, be regarded as fully qualified by examination for Leading Writer or Leading Supply Assistant. Similarly Leading Rates will, if recommended, be regarded as fully qualified by examination for Petty Officer Writer or Supply Petty Officer.

7. Paragraphs 18 to 22 of Navy Order 103 of 1943 and Navy Order 497 of 1943 are cancelled.

(559/215/1589.)

367.

RECOMMENDATIONS FOR NON-SUBSTANTIVE RATES.

The provisions of Navy Order 97 of 1943 are to apply, as far as possible, to recommendations for non-substantive rates for all Branches.

(349/25/399.)

368.

MEALS FOR R.A.N. PERSONNEL TRAVELLING BY TROOP TRAIN.

Meals for R.A.N. personnel travelling by troop train are being provided at Service expense, and the following procedure is to be observed regarding the payment of Leave, Travelling and Meal Allowances *vide* Naval Financial Regulations and Instructions, Articles 123, 136 and 137:—

- (a) No allowances are to be credited for that portion of the journey which is made by troop train.
- (b) Leave Allowance is to be credited from the date of termination of troop train travel until the date of commencement of return journey by troop train.
- (c) In the event of personnel booked to travel by troop train subsequently being required to travel by civilian train, Leave or Travelling Allowance, as the case may be, will be credited or paid on return to duty on production of supporting evidence from the Rail Transport Officer.

(401/201/3870.)

369.

**REDUCTION OF FIRE AND SMOKE RISK IN H.M.A. SHIPS—
TYPES OF PAINT TO BE USED FOR INTERIOR PAINTING.**

With reference to A.F.O. 1707/44, Zinc Chromate Primer and White Fire Retardent Paint (Non Glyptal Base) are to be used for interior painting in connexion with the reduction of Fire and Smoke risk in H.M.A. Ships.

(612/233/1123.)

370.

A.M.S. VESSELS—MODIFICATION TO FIRE MAIN AT STATION 54.

In order to improve the fire-fighting arrangements in A.M.S. Vessels, the Screw Down Valve with hose connexion fitted to the firemain at Station 54, starboard, is to be repositioned on the engine room side of the forward firemain isolating valve in accordance with the appended diagram.

2. In the event of its being necessary to close the forward and after firemain isolating valves, water will now be available at this hose connexion.

3. The Commanding Officers of A.M.S. Vessels concerned are to insert an item in the next supplementary defect list to cover this work.

(603/289/502.)

A.M.S. VESSELS.

**DIAGRAM SHOWING POSITIONS OF S.D.V.
WITH H.C. & ISOLATING VALVE ON FORP.
BRANCH OF FIRE MAIN.**

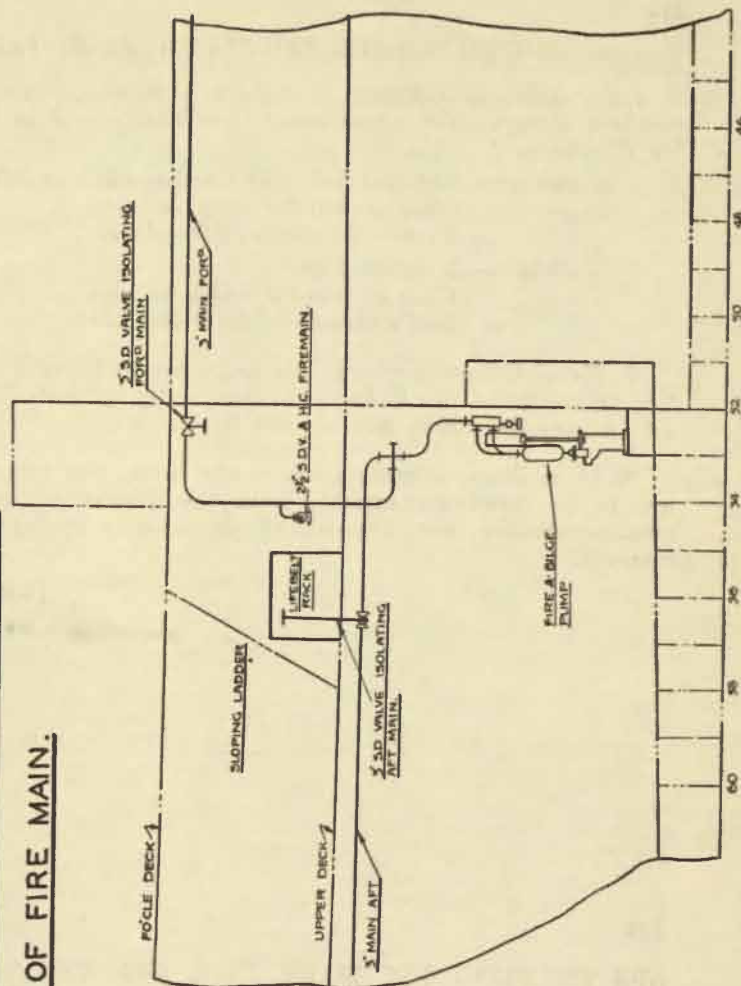

NAVY OFFICE MELBOURNE		DATE	DATE
DRG No 157/702		11-7-44	11-7-44
DATE	11-7-44	DRAWN BY	D. W.C.
		CHECKED BY	G.T.H.
		EXAMINED BY	[Signature]
		APPROVED	[Signature]

371.

PROPELLERS AND TAILSHAFTS—BASE SPARES.

Information as indicated hereunder is required quarterly of the numbers of serviceable propellers and tailshafts held as Base Spares for Warships.

Propellers—Numbers held and whether right or left hand.

Class of ship for which suitable.

Pitch—diameter—surface area.

Tailshafts—Numbers held.

Class of ship for which suitable.

Screw thread—right or left hand.

2. Naval Officers-in-Charge concerned are to forward this information on receipt of this Order and subsequently to reach Navy Office by 1st January, 1st April, 1st July and 1st October.

3. In addition, appropriations made during the preceding quarter are to be forwarded together with the dimensions, condition and recommendations for disposal of damaged propellers and shafts removed.

(656/201/260.)

372.

GUN MOUNTING 4-IN. MARK XXIII AND XXIII*—ELEVATION BUFFER STOP—REPLACEMENT OF SPRING BY DISTANCE PIECE.

The following modification is approved:—

Gun Mounting.—4-in. Mark XXIII and XXIII*.

Part Affected.—Elevation Buffer Stop.

Purpose.—To prevent Gun fouling Training Roller Unit and Two Revolution Stop at maximum Elevation.

Nature of Modification.—Spring to be replaced by Distance Piece 0.65 in. thick.

Drawing.—D.O.T.M. 54847.

By whom to be done—Gun Mounting Depots or Ordnance Base Staffs.

Degree of Urgency.—Earliest opportunity, if considered necessary.

2. Drawing has been forwarded to Bases with Navy Office letter 47999, dated 4th July, 1944.

(490/203/1183.)

373.

GUN MOUNTING 4-IN. XXIII AND XXIII*—LOWER ELEVATION GEAR BOX—FITTING OF LEATHER WASHER.

The following modification is approved:—

Gun Mounting.—4-in. Mark XXIII and XXIII*.

Part Affected.—Lower Elevation Gear Box.

Purpose.—To prevent entry of water.

Nature of Modification.—Leather Washer with Keep Plate and securing screws to be fitted to Cover.

Drawing.—D.O.T.M. 54849.

By whom to be done—Gun Mounting Depots or Ordnance Base Staffs.

Degree of Urgency.—Earliest opportunity.

2. Drawing has been forwarded to Bases with Navy Office letter 47999, dated 4th July, 1944.

(490/203/1183.)

374.

GUN MOUNTINGS 4-IN. MARK XXIII AND XXIII*—FIRING GEAR—MODIFICATION TO CATCH PIECE.

The following modification is approved:—

Gun Mounting.—4-in. Mark XXIII and XXIII*.

Part Affected.—Catch Piece for Percussion Firing Lever.

Purpose.—To prevent missfires due to Catch Piece failing to return to vertical position.

Nature of Modification.—Removal of metal and re-hardening to 0.25-in. radius on top rear cover.

Drawing.—D.O.T.M. 30869, dated 5th May, 1944, Item 3.

By whom to be done—Gun Mounting Depots or Ordnance Base Staffs.

Degree of Urgency.—First opportunity.

2. Drawing has been forwarded to Bases with Navy Office letter 47999, dated 4th July, 1944.

(490/203/1183.)

375.

ORDNANCE Q.F. 40 M.M. BOFORS—LIQUID IN RECOIL BUFFERS.

Recoil Buffers of Ordnance Q.F. 40 m.m. Bofors of all types are to be filled with oil D.T.D. 44 D. instead of glycerine and water in order to conform to Admiralty procedure.

2. All ships mounting this gun are to demand, as first supply, 1 gallon of this oil per gun.

3. Navy Order 559 of 1943 is hereby cancelled.

(490/212/918.)

376.

SPERRY MARK XIV MOD. 1 GYRO COMPASS—OILING OF UPPER VERTICAL GUIDE BEARING.

A Marine Service Bulletin issued by the Sperry Gyroscope Company, Inc., states that it has been found necessary to alter the oiling practice previously recommended for the upper vertical guide bearing and the stem bearings of the Sperry Mark XIV Mod. 1 Gyro Compass. The oiling chart in the instruction book states that these bearings should receive three drops of oil at weekly intervals.

2. It is stated that the original object of oiling these parts sparingly was to prevent any overflow from getting on the trolleys and contactors, but that recent inspections have shown the bearing to be dry, causing excessive friction.

3. The lubrication for phantom stem bearings and upper vertical ring guide bearing in the oiling chart in the instruction book is to be amended by Ship's Staff to read "Weekly—Apply ten drops". The excess oil will settle in the oil retainer cup around the bearing as intended.

(1903/2/947.)

377.

SPERRY MARK XIV GYRO COMPASS—REPEATER BEZEL SCREWS.

The bezel screws on Sperry type No. 64024 repeaters may, after exposure to the weather for some time, be very difficult to remove due to corrosion.

2. The screws should be removed and coated with anti-seize compound on the first occasion that the services of a Gyro Adjuster are available.

(1903/2/947.)

378.

SPERRY MARK XIV, MOD. 1—GYRO COMPASS—MERCURY BALLISTIC CAPS.

Errors may occur in the Gyro Compass, Mark XIV Mod. 1 due to improper flow of the mercury in the mercury ballistic. This may be caused by plugged vent holes in the caps of the mercury cups as the result of the wicks having absorbed oil vapour and dust.

2. The wicks are to be removed from the caps of the mercury cups as early as practicable.

(1903/2/947.)

379.

SPERRY MARK XIV GYRO COMPASS—CONDENSERS— FOLLOW-UP CIRCUIT.

A Marine Service Bulletin issued by the Sperry Gyroscope Company, Inc., states that instruction books show incorrect part number and rating for the Follow-up Transformer Secondary Coil Condenser of the Sperry Mark XIV Gyro Compass.

2. The condenser used with this Gyro Compass is part number 154848, rating 0.20 mfd. This has been confused with a condenser part number 127292, rating 0.25 mfd. used on another Gyro Compass.

3. Instruction books are to be amended as follows:—

- (a) In the book, "Amplifier Panel" 17-A.P.-642202A, page 9, item C1 and C2 delete ".25 mfd." and insert ".20 mfd."; delete "127292" and insert "154848".
- (b) In the book, "Amplifier Panel" 17-A.P.-642202B, page 11, item C1 and C2 delete "127292" and insert "154848".
- (c) In the book, "Amplifier Panel" 17-A.P.-642202C, page 11, item C1 and C2 delete ".25 mfd." and insert ".20 mfd."; delete "127292" and insert "154848".

(1903/2/947.)

380.

AMMUNITION—CARTRIDGES, 40 M.M. BOFORS H. E. AMMUNITION OF BRITISH LAND SERVICE MANUFACTURE FITTED WITH PRIMERS No. 18—WITHDRAWAL FROM NAVAL SERVICE—REPORT.

Appended for information and necessary action, is copy of Admiralty Fleet Order 2339/44 which has not yet been promulgated on the Australia Station:—

"The following batches of 40 mm. Bofors H.E. Ammunition of British Land Service Manufacture, which have been issued to the Navy, are fitted with Primers No. 18 and are to be withdrawn from Naval Service:—

B.824D	B.772M	B.844T	B.975A
B.845A	B.977C	B.985M	B.965G
B.992L	B.970B	B.992F	B.616E
B.977Y	B.988F	B.991K	B.831K
B.970U	B.989C	B.969U	B.831Z
B.988G	B.961X	B.970T	B.832C
B.987L	B.963T	B.987U	B.836T
B.986A	B.988N	B.987A	B.837H
B.965K	B.974U	B.988A	B.811D
B.988P	B.976A	B.963A	B.811J
B.822A	B.823T	B.990N	B.811Y
			B.803N

2. Ships having any ammunition of these Batch Nos. on board should arrange at the earliest possible date with Naval Armament Supply Officers for supply of other ammunition in replacement.

3. Boxes containing British Land Service 40 mm. Bofors H.E. Ammunition are marked with Batch Nos. (Example B.824D) without the additional marking of "CAN".

4. Boxes having the marking "CAN" in addition to the Batch No. are not involved since the ammunition is of Canadian Land Service manufacture.

5. R.N. Armament Depots—(i) Ammunition of the Batch Nos. quoted is not to be issued unless unavoidable.

(ii) A report is to be made to Director of Armament Supply, Bath (B.109) showing stock (under Batch Nos.) of any of the ammunition referred to at present held, or which may be subsequently landed by ships in accordance with this Order. On receipt of this information, disposal instructions will be given.

(iii) In the event of more than 5,000 rounds of the ammunition involved being held at any station abroad, a notification of quantity should be sent by signal to Director of Armament Supply, Bath (B.109) in order that arrangements may be made for replacement. Particulars of quantities of each Batch No. should follow by post.

6. D.E.M.S. staff officers are to take appropriate action as regards merchant ships.

7. With reference to C.A.F.O. 991/42, these stores are to be regarded under category (a).

(C.A.F.O. 991/42.)"

(408/206/1431.)

381.

**DEPTH CHARGE THROWERS, MARK IV—SECURING STROP—
SUPPLY OF SPARE WIRE SPANS.**

Spare wire spans for strops securing depth charges to the carrier of Mark IV Throwers will be allowed to H.M.A. Ships in accordance with A.F.O. 6132/43.

2. The spare spans will, however, be supplied by the R.A.N. Armament Depot, Sydney, and H.M.A. Ships and Bases are to forward demands accordingly.

(471/205/1883.)

382.

RESPIRATORS, ANTI-GAS—PAINTINGS OF HAVERSACKS.

The instruction contained in A.F.O. 3782/42 in regard to paintings of haversacks is not to be observed in the R.A.N.

(669/201/1023.)

383.

**NAVAL ARMAMENT STORE ACCOUNTS—H.M.A. SHIPS, ETC.—
CONSUMABLE STORES.**

Expenditure of the stores detailed hereunder is not required to be recorded in detail, and the letter "(S)" is accordingly to be added to these stores in Naval Armament Store Accounts:—

Guns Machine Bren .303-in. Marks I and II:—

- (S) Springs pin firing
- (S) Springs post piston
- (S) Springs return
- (S) Springs stay extractor
- (S) Stays extractor
- (S) Boxes small parts M.G. No. 4 Mark I
- (S) Brushes rod cleaning cylinder Marks I or II
- (S) Bottles oil Marks IV or V
- (S) Gauzes, pullthroughs double
- (S) Mops rod cleaning cylinder
- (S) Plugs clearing
- (S) Pullthroughs double A
- (S) Pullthroughs single Mark IV_A
- (S) Rods cleaning cylinder Bren .303-in. M.G. Mark I* or II
- (S) Extractors
- (S) Cans oil
- (S) Slings

Guns Machine Vickers .303-in. Mark I No. 1:—

- (S) Pins feed piece
- (S) Plungers feed piece spring
- (S) Screws firing pin
- (S) Springs buffer
- (S) Springs firing pin Mark II
- (S) Springs return inner
- (S) Springs return outer
- (S) Springs return Mark II
- (S) Springs sear
- (S) Pullthroughs double Mark I

Guns Machine Browning .303-in.:—

- (S) Pins ejector
- (S) Springs ejector
- (S) Springs sear
- (S) Springs breech cover catch
- (S) Springs return complete
- (S) Studs cocking
- (S) Drifts No. 6
- (S) Drifts No. 7
- (S) Drifts No. 8
- (S) Lanyard cocking
- (S) Pullthroughs double Mark I

O.Q.F. 20 mm. Oerlikon Marks II, U.S. II, U.S. IV:—

Casing breech:—

- (S) Pins securing handle locking barrel and trigger
- (S) Springs buffer
- (S) Springs catch magazine interlock and carrier
- (S) Springs catch retaining ring seating barrel spring
- (S) Springs lever locking barrel
- (S) Springs lever magazine interlock
- (S) Springs plunger catch retaining handgrip
- (S) Springs plunger stop double loading Part 3
- (S) Springs plunger stop double loading Part 4
- (S) Springs securing hammer plate

Recoiling mass:—

- (S) Pins spring bolt securing barrel spring and cotter
- (S) Springs breech pawl
- (S) Springs sear
- (S) Springs securing bolt axis sear and stop double loading Part 3
- (S) Springs securing breech facepieces

Rests shoulder:—

- (S) Springs catch retaining shoulder piece frame

Triggers Mark I or II:—

- (S) Springs bolt tripping trigger pawl
- (S) Springs buffer trigger
- (S) Springs plunger lever parallelogram rear
- (S) Springs plunger lever parallelogram top
- (S) Springs plunger lever trigger intermediate
- (S) Springs securing trigger casing
- (S) Springs trigger hook
- (S) Springs trigger pawl
- (S) Covers rubber muzzle No. 1

Magazines:—

- (S) Springs securing feed axis

Barrels:—

- (S) Springs catch retaining cap

Appurtenances and Implements:—

- (S) Brushes oil
- (S) Cams oil
- (S) Drifts copper
- (S) Hammers crosspane
- (S) Heads ejector
- (S) Lanyards cocking
- (S) Punches 3 mm.
- (S) Punches 5 mm.
- (S) Rag ends cleaning rod
- (S) Reflectors mirror
- (S) Screwdrivers double
- (S) Tool rolls

(612/205/1137.)

384.

**ACCOUNTING FOR MACHINERY, MACHINE TOOLS, ETC.,
SUPPLIED FOR NAVAL WORKSHOPS.**

With reference to Navy Order 108 of 1944, it is intended that machinery, machine tools, fixtures and fittings should be recorded on separate fixture lists for each base workshop or group of workshops and that the relevant fixture list be retained by the officer responsible for each workshop or group of workshops. For example, individual fixture lists should be raised for each of the following:—Main workshops, motor boat workshops, boom depot workshop, torpedo workshop, garages, &c.

2. Transfers of equipment between workshops should be noted and the procedure for the amendment of fixture lists observed.

3. Paragraph 6 of Navy Order 108 of 1944 is hereby cancelled and the following is to be read in lieu:—

“Upon receipt of machinery, machine tools, &c., at a base workshop, the officer responsible for the workshop is to forward to the Director of Engineering (Naval) a certificate that the equipment has been received and recorded in his List of Fixtures, the page number of the Fixture List being indicated.”

(612/212/2929.)

385.

**ACCOUNTS FOR PROVISIONS SUPPLIED TO TENDERS WHEN
ABSENT FROM PARENT SHIP.**

The following procedure is to be followed in connexion with the payment of contractors' claims for provisions supplied to tenders when absent from their parent ship, e.g., tender based on *Melville* undergoing refit at Sydney.

2. Within three days after the close of each month and/or immediately before final departure from the port, the Commanding Officer of the tender is to forward to the Base Accountant Officer of the Base to which the ship has been temporarily appropriated for service or refit, a statement, certified as indicated hereunder, of all fresh provisions received direct from contractors for the month or period.

Certificate to be signed by the Commanding Officer—

“The items and quantities of provisions stated above have been entered in Form A.S.92 and taken on charge accordingly in the relevant Form A.S.462Z—Provision Account.

Commanding Officer.”

3. Contractors are also to be advised that claims are to be rendered to the local Base Accountant Officer.

4. Upon receipt of the certified statement referred to in paragraph 2, the Base Accountant Officer is to check the details against contractors' claims and, if in order, effect payment accordingly. The certified

statement is then to be endorsed with the name of the paying officer and consecutive payment voucher number and forwarded, with the triplicate copy of the voucher/s, to the Accountant Officer of the parent ship of the tender concerned for subsequent check against entries in the tender's provision account.

5. Reference to this Order should be made against Navy Order 217 of 1944.

(401/201/3956.)

386.

BEDDING FOR W.R.A.N.S.

Navy Order No. 169 of 1944 is to be amended as follows:—

Add after last item—

Item; R.N. Allowance as per A.F.O's.; R.A.N. Allowance.

Pillows, hair; 1 per Officer, 1 per Rating; 1 per person.

Pillows, feather; 1 per officer, nil per rating; nil.

(612/235/860.)

387.

KING'S REGULATIONS AND ADMIRALTY INSTRUCTIONS— REPRINT.

Demands are being received for the 1941 edition of B.R.31, 32 and 32A, obviously to replace earlier editions held, contrary to instructions.

2. The 1941 edition is a reprint only, containing all amendments up to the end of 1941 and issues are restricted to New Services and for replacement of copies worn out only, *vide* A.F.O. 4504/1943.

(571/201/3998.)

388.

BOOKS AND FORMS.

First supplies of the under-mentioned publications have been distributed. Further supplies of Errata No. 3 to B.R.369 is being obtained to complete distribution.—

Kemp's Engineer's Year Book, 1944.

(571/202/1655.)

B.R.155/1943.—Diving Manual.

(A.F.O's 6051 and 6288/43.)
(571/202/1863.)

B.R.222.—Notes on W/T Sets—Additional Pages—

R.S.1—R.S.27, R.W.21—R.W.41, A.A. 1, 27, C.43—68,
R.Q.1—15, R.V.1—11, R.W.1—20.

(A.F.O's 234 and 889/44.)
(571/202/1841.)

List of Errata 10 to B.R.332A—

Establishment of Naval Stores for Flotilla Leaders and Destroyers and Form D.117B—List of Particulars for Flotilla Leaders, Destroyers and Fast Minelayers.

(A.F.O's 4367 and 5422/43.)
(571/202/1393.)

Errata Nos. 1, 2 and 3 to B.R.369—

Establishment of Naval Stores for Controlled Mining Base.

(A.F.O's 647, 3760/43 and 889/44.)
(571/202/1879.)

B.R.569.—"Practical Construction of Warships" by R. N. Newton.

(A.F.O. 2813/42.)
(571/202/1569.)

B.R.778/43.—Handbook and Drill for the 2-pdr. Q.F., Mark VIII Gun on Single Mark XVI Mounting (Powered).

(A.F.O's 2563 and 6175/43.)
(571/202/1776.)

B.R.799 (late B.R.115).—Merchant Ship Description—Code and Primer.

(A.F.O. 4233/43.)
(571/202/1831.)

B.R.869.—Guard Book and Index for Gunnery Cameras and Uses, 1943

B.R.869 (2) (late O.U.6303).—Cinematograph Marking of Long Range H.A. Practices, 1943.

B.R.869 (3) (late B.R.613/42)—Instructions for the use of the Dial Recording Camera Mark III (Pat. 2442), 1943.

(A.F.O's 363 and 889/44.)
(571/202/1917.)

B.R.901/43.—Handbook of the Admiralty Fire Control Clock, Marks I and I*.

(A.F.O. 1885/43.)
(571/202/1925.)

Handbook of the Fuze Keeping Clock and Associated Equipment, Volume II, B.R. Series.

B.R.913.—Guard Book and Index for Pamphlets.

B.R.913 (10).—The Fire Control Box, Mark V.

(A.F.O's 5796 and 5797/43.)
(571/202/1857.)

B.R.1034 Series (late C.B.4239 Series).—Handbook of Components and Testing Apparatus for Independent Non-Contact Mines.

B.R.1034 (3).—Pamphlet No. 3—Batteries.

B.R.1034 (4).—Firing Switches and Similar Devices.

B.R.1034 (6).—Condensers.

B.R.1034 (7).—Detonators.

B.R.1034 (8).—Primers.

B.R.1034 (11).—Hydrostatic Switches.

B.R.1034 (12).—Anti-Countermining Devices.

(A.F.O. 1887/44.)
(571/202/1949.)

O.U.6353.—October Supplement and Amendments—British Merchant Ships Lost.

O.U.6353A.—October Supplement and Amendments—Foreign Merchant Ships Lost and Damaged by the Enemy.

(A.F.O. 234/44.)
(571/203/2460.)

A.P.1480/1.—Amendment List No. 21—Silhouettes of American Aircraft.

A.P.1480Z/2.—Amendment List No. 2—D.E.M.S. Aircraft Recognition Handbook.

A.P.1480F.—Amendment No. 17.—Silhouettes of Japanese Aircraft.

(A.F.O's 234 and 889/44.)
(571/201/4155.)

O.N.I.41.—Surface Views of Japanese Warships.

(571/201/4228.)

O.N.I.42.—Aerial Views of Japanese Warships.

(571/201/4230.)

O.N.I.41-42.—Japanese Naval Vessels.

(571/201/4229.)

O.N.I.54R.—U.S. Naval Ships and Aircraft.

(571/201/4231.)

O.N.I.200A.—Aerial Views of United States Naval Vessels.

(571/201/4233.)

O.N.I.208J.—Japanese Merchant Ship Recognition Manual.

(571/201/4242.)

O.N.I.232.—Japanese Military Aircraft.

(571/201/4232.)

O.N.I.249.—Japanese Aircraft Manual.

(571/201/4241.)

BUAER 3.—Recognition Pictorial Magazine.

(571/201/4243.)

2. The under-mentioned form has been adopted for use in the R.A.N. Supply will be made, on demand, when stock of the Asdic and Hydrophone Journal (Revised March, 1936) is exhausted:—

S.320 (revised April, 1941).—"Asdic" Journal.

(C.A.F.O. 1311/41.)
(480/202/4302.)

389.

CORRIGENDUM.

With reference to Navy Order 266 of 1944—"Food Coupons—Naval Personnel"—paragraph 5, alter "6 to 10 days" to read "8 to 10 days".

(350/201/85.)

By Authority: H. E. DAW, Government Printer, Melbourne.

RESTRICTED.

(FOR OFFICIAL USE ONLY.)

Commonwealth Navy Orders.

Navy Office, Melbourne,

1st August, 1944.

The following Orders, having been approved, are hereby promulgated for information and guidance and necessary action.

By direction of the Naval Board,

Godfray
Secretary.

*The Commodore Commanding H.M.A. Squadron,
and Commanding Officers of H.M.A. Ships,
Officers in Charge of H.M.A. Naval
Establishments, and others concerned.*

TABLE OF CONTENTS.

No.	Subject.
390.	H.M.A. Shore Establishments—Name Ships.
391.	Submarine Detector Ratings—Selection and Aural Care of.
392.	Passages to Australia for Dependants of Members of the Forces who have Married Abroad.
393.	H.M.A. Ships—Use of Zinc Plates for Protecting Boilers.
394.	Guns, Machine, 0.303-in. Bren and 0.303-in. Vickers G.O.—Modification to Magazines and Repair Magazine Main Springs.
395.	Guns, Machine, 0.303-in. Vickers G.O.—Modification to Magazines to Prevent Wrong Assembly.
396.	Safe Operating Procedures for Welding and Cutting.
397.	Muster of Binoculars, Telescopes, Watches, and Heliographs.
398.	Medical Stores—Scale Service Afloat 1943—Amendments Nos. 1 and 2.
399.	Medical Stores—Scale—"Sick Quarters"—Amendments Nos. 1 and 2.
400.	Medical Stores—Scale—"Base Depot Sick Bays"—Amendments Nos. 1 and 2.
401.	Medical Stores—Scale "C"—Amendments Nos. 1 and 2.
402.	Naval Stores Lost by Accident, Neglect, or Theft—Procedure.
403.	Saline (Salt) Tablets.
404.	Non-Delivery of Victualling Stores Consigned to H.M.A. Ships and Establishments.
405.	Contracts for Supply of Ratings' Made-to-Measure Uniforms.
406.	Contracts for Supply of W.R.A.N.S., Ratings' Made-to-Measure Jackets and Skirts.
407.	Supply of Officers' Uniforms, Including Uniforms for R.A.N. Nurses and W.R.A.N.S. Officers.
408.	Chocolate and Confectionery for Naval Canteens.
409.	Printed Forms.
410.	Second Victory Loan.

C.8013/44.

390.

H.M.A. SHORE ESTABLISHMENTS—NAME SHIPS.

With reference to Navy Order 177 of 1943, H.M.A. L.C.A. 3021 has been renamed H.M.A.S. *Kuranda*.

2. Navy Order 270 of 1944 is cancelled.

(404/201/557.)

391.

SUBMARINE DETECTOR RATINGS—SELECTION AND AURAL CARE OF.

Attention is drawn to A.F.O. 1319 of 1944 on the selection and aural care of submarine detector ratings, in which are laid down the aural threshold and pitch discrimination to be attained by all submarine detector ratings, and in which it is indicated that all ratings of this Branch are to have their ears examined by a medical officer every three months.

(527/203/799.)

392.

PASSAGES TO AUSTRALIA FOR DEPENDANTS OF MEMBERS OF THE FORCES WHO HAVE MARRIED ABROAD.

With reference to Navy Order 600 of 1943, dependants of members of the Forces who marry during the period of their active service abroad may now be granted third or equivalent class passages to Australia by the Repatriation Commission entirely free of cost to the members concerned. The number of passages granted during the war, however, will still be governed by the shipping accommodation available.

2. Representatives, appointed by the Commission to receive applications on account of dependants residing in India, and the United States of America and Canada, are respectively the R.A.A.F. Liaison Officer, New Delhi, and the Official Secretary, High Commissioner's Office, Ottawa.

(632/211/973.)

(This Order will be reprinted for posting on Notice Boards.)

393.

H.M.A. SHIPS—USE OF ZINC PLATES FOR PROTECTING BOILERS.

With reference to Navy Order 124 of 1942, in view of the improved supply position in relation to zinc, it has been decided to revert to the practice of using zinc protectors for under-water fittings and surfaces of H.M.A. Ships.

2. Demands for requirements of zinc plates should be forwarded to the nearest Storing Yard, where supplies will be made available as early as practicable.

(532/201/1164.)

394.

GUNS, MACHINE, 0.303-IN. BREN AND 0.303-IN. VICKERS G.O.—MODIFICATION TO MAGAZINES, AND REPAIR OF MAGAZINE MAIN SPRINGS.

The modification and repair of magazines of Guns, Machine, 0.303-in. Bren and 0.303-in. Vickers G.O., in accordance with A.F.O. 6114/43, is to be carried out by Base Staff at ports where there is no Naval Armament Depot and where the necessary facilities are available.

(490/212/1116.)

395.

GUNS, MACHINE, 0.303-IN. VICKERS G.O.—MODIFICATION TO MAGAZINES TO PREVENT WRONG ASSEMBLY.

The stamping of the word "TOP" on magazines of Guns, Machine, 0.303-in. Vickers G.O., in accordance with A.F.O. 146/43, is to be carried out where possible by Base Staff at ports where there is no Naval Armament Depot.

(490/212/1116.)

396.

SAFE OPERATING PROCEDURES FOR WELDING AND CUTTING.

Appended are instructions, which have been issued to welders operating in H.M.A. Naval Dockyard, Garden Island, Sydney, with the objects of—

- (i) preventing fires;
- (ii) ensuring care of and attention to oxy-acetylene apparatus; and
- (iii) extinguishing fires that may be started by welding and cutting plants.

2. Owing to the great risk of fire in ships refitting and consequent damage which may be caused directly or indirectly by contractors' employees and dockyard employees using appliances with a naked flame, the following instructions are issued to minimize the fire risks:—

- (a) A responsible Ship's Officer is to be informed by the Dockyard Officer in charge of the refit that welding, cutting, burning, or hot riveting is to be carried out, and the locality in which the work is to be done shall be plainly stated.

- (b) In confined places aboard vessels where it is necessary to operate, the work is not to be commenced without the written sanction of a responsible Dockyard Officer. In connection with oil fuel tanks, no work is to be undertaken until a certificate, signed by the Engineer Officer of the ship in accordance with Eng. Manual, Article 389, clause 7, is completed and handed to the Dockyard Officer.
- (c) Wherever possible, items that are portable and which require welding or burning are to be removed to a safe area.
- (d) Whenever welding, cutting, burning, or hot riveting is to be carried out in its original position, every precaution is to be taken to avoid damage by the heat of the particular operation being transmitted through the bulkhead, deck or deckhead, to stores and fittings in adjacent compartments.
- (e) A thorough inspection of the locality is to be carried out, and inflammable material is to be cleared away from the site of operations. Wooden floors or decks are to be dampened down with water and protected with asbestos sheets. All openings, cracks, &c., are to be covered to prevent slag and heated metal making contact with inflammable material. The welder's assistant is to keep a close watch on slags and sparks during welding and cutting.
- (f) Close port holes or hatches in the vicinity to where welding, burning, or hot riveting is being carried out to prevent sparks being carried into other compartments.
- (g) Special precautions are to be taken where pipe lines are involved. Pipe lines are not to be welded in place, if this can be avoided—the portion requiring attention being removed for treatment. If treatment in place cannot be avoided, however, ascertain what the pipe contains; fuel oil, petrol, steam, water, electric cables, or air. Make sure the pipe has been thoroughly drained before operating. There may be a small quantity of fuel oil left in an elbow or bend close to where the weld or cut is to be made, sufficient to cause a fire. No welding is to be carried out on any pipe in any place without first ascertaining that—
- (i) the pipe does not pass through spaces containing inflammable material; and
 - (ii) the pipe does not contain, nor is likely to contain, any trace of combustible material for a distance of at least 6 feet from the weld or cut. Welding in place is prohibited on pipes, any portion of which passes through a compartment containing explosives.

- (h) Where oxy-acetylene, electric welding apparatus, blow lamps, or naked lights are in use, a fire extinguisher is to be kept in close proximity while work is in operation.
- (i) Where oxy-acetylene or other oxy gas plants are in use, care is to be taken that the oxygen supply is turned on first when starting to use the blow pipes, and that the acetylene or other gas is turned off first when ceasing work.
- (j) Oxy-acetylene torches are to be lit with mechanical flint lighters, improvised igniters such as a piece of smouldering rope, &c., are strictly forbidden.

BLOW LAMPS.

The fuel used in blow lamps and grazing apparatus is to be paraffin. Petrol or similar fuel of low flash point or high volatility is on no account to be used with these lamps.

Suitable precautions are to be taken when they are in use to ensure against the possibility of fire.

The containers of all blow lamps in service are to be subjected to a pressure test at intervals of six months, also when repairs have been made.

A quart-size pyrene extinguisher is to be issued with each blow lamp drawn from the Tool Store, and placed ready for use adjacent to where the blow lamp is to be used.

Safety-first measures are to be adopted by always having at hand a quantity of sand, water or chemical extinguishers to combat an outbreak of fire.

A thorough inspection is to be made by the chargehand of the locality after all operations in which burning, welding, cutting, or using blow lamps has been carried out.

NOTE.—Ships' orders and regulations concerning smoking are to be adhered to, and care is to be taken that contractors' employees and dockyard employees do not smoke in places in which smoking would be dangerous.

3. A permit in the form set out hereunder is to be obtained before operations are commenced:—

PERMIT FOR USE OF WELDING OR BURNING EQUIPMENT ON BOARD H.M.A. SHIPS.

This permit is to be signed by the officer responsible for the supervision of the work.

The form is to be completed by the chargehand in charge of the work.

He is to inspect the site of the operation before it takes place and check that there is no risk of fire. He is to hand this permit to the welder, after it has been signed by the supervising officer, before allowing work to proceed.

On completion of the operation the chargehand is to inspect the locality and endorse this permit to the effect that there is no sign of fire. The certificate is then to be returned to the supervising officer.

"Name of ship: _____ Date _____
 Description of work: _____
 Name of welder: _____
 Has site been inspected and all combustible material cleared away?
 Do you consider it safe from risk of slag and sparks causing fire?
 Are electric cables clear?
 Is there any inflammable material in pipes or compartment adjacent?
 Has welder a fire extinguisher?
 Chargehand's signature:

Signature and rank of supervising officer.

I have examined the locality on completion of the operation and consider it to be safe from fire.

.....
 Chargehand."

4. Dockyard officers, principal naval overseers, base engineer officers, and others concerned are to ensure that the foregoing procedure is followed when His Majesty's and Allied Ships are building, completing, fitting-out, or refitting under their supervision.

(449/203/400.)

397.

MUSTER OF BINOCULARS, TELESCOPES, WATCHES, AND HELIOGRAPHS.

A comprehensive and careful muster of all of the following valuable items of Naval Stores is to be carried out by all H.M.A. Ships and Establishments, including M.L's, Port Director Units, detached Officers, &c.:—

Binoculars.
 Telescopes.
 Watches.
 Heliographs.

2. Reports are to be furnished to Navy Office as early as practicable indicating:—

- (a) The registered numbers of the items.
 (b) Any items in excess of those authorized to be carried.
 (c) Any items in excess of those shown on charge in the Naval Store Account.

(670/201/868.)

398.

MEDICAL STORES—SCALE SERVICE AFLOAT, 1943—AMENDMENTS Nos. 1 AND 2.

AMENDMENT No. 1.

The following alterations are to be made in copies of Scale Service Afloat Medical Stores, 1943, by all holders thereof:—

Amendments:

"Form A.M. 1782" to read "A.M. 178A".

Page 12, Item 882/0 Quantities to read "lb. 2 3 5 8".

Deletions:

Form A.M. 143 Scale contents F.S.

Valise

Form A.M. 254z Statement by Officer or Man of Own Case

Page 3, Item 873/6 (Ampoules) Water, distilled, sterile

Page 3, Item 153/0 (Quantities only)

Additions:

Page 2, Item 560/5 (Ampoules) Penicillin, of 100,000 Oxford Units ..

Page 3, Item 58/1 (Ampoules) Aqua distillata sterile, pyrogen free, 10 c.c. ampoules

Page 3, Item 153/0 Calamina praep. ..

Page 17 Add Section "Hospital Clothing"—

Gowns, Operating Theatre ..

Gowns, Staff Ward ..

Shirts, Calico ..

Slippers (size 6 to 10) ..

amps.	30	60	108	144	
lb.	1	2	3½	5	
amps.	10	50	50	50	
amps.	50	600	650	700	
lb.	2	3	5	8	
No.	4	9	12	18	
No.	4	9	12	18	
No.	24	48	72	84	
prs.	2	4	6	8	

Books and Forms:

A.A.F.—D. 109 Malaria Forms (Card Report)

A.F.—W. 3118 Malaria Forms (Field Medical Card)

W. 3118A Malaria Forms (Envelope)

A.M. 114z Sea-sickness Report ..

A.M. 121w Gonococcal Case Sheet ..

A.M. 301z Medical Status of Personnel recommended to be Invalidated ..

Page 13 Arm Bands—"Red Cross" No.

Arm Bands—"S.B." .. No.

As required.

According to number of medical personnel and stretcher-bearers borne.

AMENDMENT No. 2.

Additions:		Denom.	100-500.	300-500.	500-700.	700-900.
Item	28/7 Albuclid Solution, 2½ per cent. ..	oz.	4	8	12	16
"	38/7 Amyl Salicylate ..	lb.	1	2	3	4
"	111/9 Blower, Powder—					
	(a) Complete ..	No.	1	2	3	3
	(b) Bulb I.R. Spare for ..	No.	When required only.			
	(c) Air filter, glass, with I.R. connection ..	No.	1	2	3	3
"	188/5 Cellophane 30" x 36"	Shts.	5	5	10	10

2. Item 111/9 will be issued without demand as stocks become available. (612/213/2671.)

**MEDICAL STORES—SCALE—"SICK QUARTERS"—
AMENDMENTS Nos. 1 AND 2.**

AMENDMENT No. 1.

The following alterations are to be made to the Scale of Medical Stores for "SICK QUARTERS" by all holders thereof:—

Amendments.

- Item 775/0 to read "775/4 Tabs oral Ferri Sulph."
Item 561/0 (ampoules) Pentothal Sodium 60 doz. to read "6 doz."
Item 485/0 (Path. & Disp.) Mortar & Pestle, to read "Mortar & Pestle (a) Composition No. 4 medium."

Deletions.

- Item 873/6 (ampoules) water distilled sterile in 10 c.c., Amps. 288.
Form A.M. 245z Statement of Officer or Man on his own Case.
Form A.M. 143 Scale Contents F.S. Valise.

Additions.

- Item 58/1 (ampoules) Aqua Distillata, Sterile, pyrogen free, 10 c.c. amps.—No. 288 and as required.
Item 560/5 (ampoules) Penicillin, amps. of 100,000 Oxford Units—as required.
Item 683/7 Sodi Phosphas Acidus—2 lb.
Form A.A.F.D. 109 Malaria Forms (Report Card)—as required.
Form A.F.W. 3118 Malaria Forms (Field Medical Card)—as required.
Form W3118A Malaria Forms (Envelope)—as required.
Form A.M. 114z Seasickness Report—as required.
Form A.M. 121w Gonococcal Case Sheet—as required.
Form A.M. 301z Medical Status of Personnel recommended to be invalidated—as required.

Section headed "HOSPITAL CLOTHING"—

Gowns, O.T.	18 No.
Gowns, Staff Ward	18 No.
Shirts, Calico	84 No.
Slippers (sizes 6 to 10)	12 pairs.

AMENDMENT No. 2.

Additions.

	Sick Quarters.
Page 2, Item 28/7, Albucid Sol'n $z\frac{1}{2}$ per cent.	12 oz.
Page 2, Item 38/7 Amyl Salicylate	.. 3 lb.
Page 4, Item 188/5, Cellophane 30-in. x 36-in.	10 Sheets.
Page 4, Item 111/9, Blower, Powder—	
(a) Complete 2 No.
(b) Bulb, I.R. Spare for When required only.
(c) Air Filter, glass, with I.R. connection	2 No.

2. Item 111/9 will be issued without demand as stocks become available.

(612/213/2507.)

**MEDICAL STORES—SCALE—"BASE DEPOT SICK BAYS"—
AMENDMENTS Nos. 1 AND 2.**

AMENDMENT No. 1.

The following alterations are to be made in the Scale of Medical Stores for "BASE DEPOT SICK BAYS" by all holders thereof:—

Amendments.

- "Item 775/0 Tabs oral—Ferri Sulph.," amend to read "775/4."

Deletions.

- Item 873/6 (Ampoules) Water distilled, Amps. 288.
Form A.M. 143, Scale contents F.S. Valise.
Form A.M. 254z, Statement by Officer or Man of own Case.

Additions.

- "Item 58/1 (Ampoules) Aqua Distillata—pyrogen free, 10 c.c. amps.—Amps. 288 and as required.
Item 560/5 (Ampoules) Penicillin, Amps. of 100,000 Oxford Units—Amps. as required.
Form A.A.F.-D.109 Malaria Forms (Card Record)—as required.
Form A.F.-W.3118 Malaria Forms (Field Medical Card)—as required.
Form A.F.-W.3118A Malaria Forms (Envelope)—as required.
Form A.M. 114z Seasickness Report—as required.
Form A.M. 121w Gonococcal Case Sheet—as required.
Form A.M. 301z Medical Status of Personnel recommended to be invalidated—as required."

Section headed "HOSPITAL CLOTHING"—

Gowns, Operating Theatre	12 No.
Gowns, Staff Ward	12 No.
Gowns, Flannel	12 No.
Shirts, Calico	36 No.
Slippers (sizes 6 to 10)	6 pairs."

AMENDMENT No. 2.

Additions.

	Base Depots.
Page 2, Item 28/7, Albucid Sol'n $2\frac{1}{2}$ per cent.	4 oz.
Page 2, Item 38/7, Amyl Salicylate	.. $\frac{1}{2}$ lb.
Page 4, Item 188/5, Cellophane 30-in. x 36-in.	5 Sheets.
Page 4, Item 111/9, Blower, Powder—	
(a) Complete 1 No.
(b) Bulb, I.R. Spare for When required only.
(c) Air Filter, glass, with I.R. Connection	1 No.

2. Item 111/9 will be issued without demand as stocks become available.

(612/213/2577.)

401.

MEDICAL STORES—SCALE "C"—AMENDMENTS Nos. 1 AND 2.

AMENDMENT No. 1.

The following alterations are to be made in copies of Scale "C" Medical Stores by all holders thereof:—

Amendments.

Page 2—"Item 603/1 Pulv. Alkalinus", amend to read "603/0".

Page 4—"Item 465/0 Measure, glass, medicine (b) 2 oz.", amend to read "Item 464/0 Measure, glass, graduated to 120 minims (b) 2 oz.".

Page 6—"Item 391/4 Catgut Sterile in tube, 20 days, 175/1", amend to read "175/2".

"Item 391/4 Knife, Bard Parker, Handle No. 4 407/0 (a)", amend to read "407/0 (b)".

Page 7—"Item 710/0 Splinting wire, Cramer (b) 5-in. x 3-in.", amend to read "15-in. x 3-in.".

Page 8—Form A.M. 179, Delete part 5 of Medical Journal Parts.

Additions.

Page 2—Add "Item 440/0 Liquor Hydrogen Peroxide (100 volume) 2 lb".

Page 3—Add "Item 781/3 Tabs Oral Sulphanilylguanadine (To be drawn from Base M.O. when working in *New Guinea Area only*)".

Page 4—Add Section "HOSPITAL CLOTHING"—

"Gowns, Staff, Ward	3 No.
Gowns, Flannel	2 No.
Shirts, Calico	3 No.
Slippers (size 6 to 10 to be stated) ..	4 pairs."

Page 6—Under heading "Instrument Roll Naval No. 1.", add—

"Pouch Khaki Drill for Instruments 594/1—1 No."

Page 8—Add "Form A.M. 114z. Seasickness Report—12 No."

Page 8—Delete "Form A.M. 57w x & y" and add "Form A.M. 177g Medical Store A/c—3 No."

AMENDMENT No. 2.

Additions.

Page 2, Item 28/7, Albucid Sol'n 2½ per cent. 4 oz.

Page 2, Item 38/7 Amyl Salicylate .. 8 oz.

Page 4, Item 188/5, Cellophane 30-in. x 36-in. 5 Sheets.

Page 4, Item 111/9, Blower, Powder—

(a) Complete	1 No.
(b) Bulb, I.R. Spare for	When required only.
(c) Air Filter, glass, with I.R. Connection	1 No.

2. Item 111/9 will be issued without demand as stocks become available.

(612/213/2451.)

402.

NAVAL STORES LOST BY ACCIDENT, NEGLECT, OR THEFT—PROCEDURE.

The attention of Commanding Officers and others concerned is specially drawn to Articles 1130, 1936, and 1938 of K.R. & A.I., and to Articles 72 and 73 of the Naval Storekeeping Manual, B.R.4, and paragraphs 52 and 53 of the R.A.N. Supplement thereto, in regard to the procedure to be observed when Naval Stores are lost or stolen.

2. It has been brought to notice that in many cases the loss of valuable stores has not been reported in detail to the Naval Board at the earliest opportunity as provided in those Instructions.

3. In some instances, losses have not at any time been reported to Navy Office, and have only been disclosed on the examination of the Naval Store Account concerned.

4. It is desired that special care be exercised in future to ensure strict compliance with the procedure specified.

(612/212/2830.)

403.

SALINE (SALT) TABLETS.

Stocks of Saline (Salt) Tablets are now being maintained at Sydney and at Brisbane. Demands to meet requirements of H.M.A. Ships and Naval personnel in forward areas should be forwarded to the Superintending Victualling Store Officer, Royal Edward Victualling Yard, Sydney, or the Victualling Store Officer, Brisbane.

(612/213/2706.)

404.

NON-DELIVERY OF VICTUALLING STORES CONSIGNED TO H.M.A. SHIPS AND ESTABLISHMENTS.

Many instances are occurring of omission by H.M.A. Ships and Establishments to notify Victualling Store officers of the non-delivery of victualling stores, delaying such notification for a considerable period and omitting to render Form A.D. 690 to Navy Office where stores are damaged or lost in transit.

2. In many instances, also, no steps are taken to trace missing consignments when delivery has not been made within a reasonable period after receipt of notification of despatch.

3. Remedial action is to be taken.

(612/254/1803.)

405.

CONTRACTS FOR SUPPLY OF RATINGS' MADE-TO-MEASURE UNIFORMS.

Contracts have been arranged in Melbourne, Sydney, Brisbane, Adelaide, Perth, and Hobart with the previous contractors for the supply of ratings' made-to-measure uniforms, for the period ending 28th February, 1945.

2. The contracts have been arranged for the convenience of ratings who wish to purchase made-to-measure garments and particular attention is invited to the conditions set out in paragraph 5 (d). Ratings should insist on contractors observing the conditions, which provide for at least one try-on in the basted or unfinished condition, and a final try-on in the finished state, in order to ensure satisfactory fit.

3. The names and addresses of the contractors are:—

Melbourne.—David Lack Pty. Ltd., Finlay's Buildings, corner Little Lonsdale and Elizabeth streets.

Sydney.—David Jones Ltd., Marlborough-street, Surry Hills.

Brisbane.—Rothwells Outfitting Ltd., 237-241 Edward-street.

Adelaide.—Coultras and Sons, Synagogue-place, off Rundle-street.

Perth.—National Clothing Co. (1939) Ltd., 40 King-street.

Hobart.—Garretts Pty. Ltd., 102 Bathurst-street.

4. The prices for the supply of the uniforms are as follows, and are inclusive of the cost of all materials:—

	Melbourne Contract.	Sydney Contract.	Brisbane Contract.	Adelaide Contract.*	Perth Contract.†	Hobart Contract.
	£ s. d.	£ s. d.	£ s. d.	£ s. d.	£ s. d.	£ s. d.
Jacket, double-breasted, diagonal serge, with gilt buttons—C.P.O.	2 18 0	2 19 6	3 17 10	3 10 9	3 10 7	2 15 1
Jacket, double-breasted, diagonal serge, with gilt buttons—P.O. . .	2 16 0	2 18 7	3 17 4	3 9 3	3 9 1	2 15 1
Jacket, double-breasted, diagonal serge, with horn buttons . .	2 13 0	2 18 0	3 16 5	3 6 3	3 7 3	2 13 3
Waistcoat, diagonal serge, with gilt buttons	0 16 6	0 13 7	1 7 7	0 16 3	1 3 2	0 18 8
Waistcoat, diagonal serge, with horn buttons . .	0 14 9	0 13 1	1 7 1	0 15 3	1 2 7	0 18 7
Trousers, diagonal serge, with fly . .	1 5 9	1 6 7	1 7 8	1 8 9	1 10 5	1 10 2
Jackets, single-breasted, seamen's serge, with gilt buttons—C.P.O.	2 12 0	2 16 7	3 12 6	3 9 0	3 2 2	2 13 8

CONTRACTS FOR SUPPLY OF RATINGS' MADE-TO-MEASURE UNIFORMS
—continued.

	Melbourne Contract.	Sydney Contract.	Brisbane Contract.	Adelaide Contract.*	Perth Contract.†	Hobart Contract.
	£ s. d.	£ s. d.	£ s. d.	£ s. d.	£ s. d.	£ s. d.
Jackets, single-breasted, seamen's serge, with gilt buttons—P.O. . .	2 11 6	2 15 7	3 12 0	3 7 9	3 0 7	2 13 1
Jackets, single-breasted, seamen's serge, with horn buttons . .	2 8 6	2 15 3	3 11 4	3 4 9	2 18 10	2 11 10
Waistcoats, seamen's serge, with gilt buttons . .	0 16 0	0 13 3	1 7 4	0 16 0	1 2 0	0 18 6
Waistcoats, seamen's serge, with horn buttons . .	0 13 9	0 12 10	1 6 10	0 15 3	1 1 6	0 18 6
Trousers, seamen's serge, with fly . .	1 3 6	1 6 0	1 7 5	1 6 9	1 8 8	1 9 5
Tunics, drill, with gilt buttons—C.P.O. . .	1 10 9	1 19 3	2 6 9	1 18 6	1 8 10	1 4 5
Tunics, drill, with gilt buttons—P.O. . .	1 9 9	1 18 5	2 5 9	1 18 6	1 7 7	1 4 5
Tunics, drill, with horn buttons . .	1 8 3	1 18 1	2 5 5	1 18 3	1 7 4	1 4 2
Tunics, drill, without buttons—C.P.O. . .	1 9 6	1 17 10	2 5 1	1 17 9	1 6 11	1 3 9
Tunics, drill, without buttons, other ratings	1 7 9	1 17 10	2 5 1	1 17 9	1 6 11	1 3 9
Trousers, white drill, with fly . .	0 19 9	1 0 9	1 0 11	1 5 6	1 4 5	1 0 5
Jumpers, seamen's serge	1 10 0	1 3 4	‡	1 11 3	1 14 1	1 6 4
Trousers, seamen's serge, with fall . .	1 5 3	1 6 3	‡	1 9 3	1 10 0	1 3 6
Jumpers, drill . .	1 6 3	1 0 2	‡	1 4 9	1 8 8	1 1 5
Trousers, drill, with fall . .	1 1 3	1 3 7	‡	1 8 0	1 6 1	1 1 1
Overcoats, blue cloth, with gilt buttons . .	4 1 6	4 11 3	‡	4 6 9	4 17 0	4 16 3
Overcoats, blue cloth, with horn buttons . .	4 0 0	4 10 1	‡	4 6 0	4 15 0	4 15 9

* Discount of 5 per cent. for cash in 14 days.

† All garments under the Perth contract must be paid for in cash. Allotments will not be accepted.

‡ Not included in Brisbane contract.

5. The conditions of the contract remain the same and are as follows:—

(a) When ordering garments, the rating must present to the contractor a written authority signed by the applicant's

Commanding Officer, or alternatively by a Senior Executive Officer and countersigned by the Accountant Officer, where one is borne. Such authority is to state the rating's name, official number, rating and establishment in which serving, and must specify in detail the articles and quantities thereof authorized to be purchased. Unless such an authority containing full details is presented, the order will not be accepted.

- (b) With the exception of the contractor at Perth, the rating may declare an allotment in favour of the contractor to pay for garments ordered, or may pay cash, whichever is desired. In the case of the National Clothing Co. Ltd., Perth, all garments ordered are to be paid for in cash. Messrs. Coultas and Sons, Adelaide, will allow a discount of 5 per cent. where payment is made by cash within fourteen days of delivery.
- (c) The rating shall sign the order book of the contractor when placing order and shall state in writing in what manner he intends to pay for garments ordered. He shall make an initial payment of at least five shillings.
- (d) The garments ordered shall be made by the contractor to the measurement of the rating and shall be tried on at the contractor's premises at least once in the basted or unfinished condition and again in the finished state.
- (e) The garments shall be made to the complete satisfaction of the rating, but shall conform to Service requirements and specifications held by the contractor. Certain extras are permissible and are as follows:—

Classes I and III—

	Extra charge.
	£ s. d.
Extra inside pocket in single-breasted jackets	0 0 9
Hip pocket	0 1 3
Extension bands and pleats	0 0 9
Leather bindings on trouser bottoms	0 0 3
Sewing on of badges and chevrons	0 0 9
Fob pocket	0 1 0

Class II—

Sewing on of badges and emblems	0 0 9
Zipp fasteners (if stocks held by contractors)	0 2 3
Trousers, fly, with straight tops, fitted with loops for belt—No extra charge involved.	

- (f) Completion of garments shall be effected within at least fourteen days from date of measurement of the rating or as otherwise arranged by mutual consent between the rating and the contractor, the delivery period to be subject to the rating attending for "try-on" on the date specified by the contractor.

- (g) Delivery of garments shall be taken at the contractor's premises or otherwise at the rating's expense.

6. In addition to the supply of personal requirements of made-to-measure garments, the contract provides for the supply of garments against official orders in circumstances where this may be necessary. In these circumstances the following conditions shall apply:—

- (a) Orders shall be placed by Accountant Officers on Treasury Form 21 accompanied by properly completed self-measurement form (if ratings are unable to attend for measurement) and Form N.A.4.
- (b) Garments shall be completed within fourteen days of receipt by the contractor of the official order and delivered by parcels post to the address shown thereon, postal charges being to the account of the ship or establishment concerned.
- (c) Unsatisfactory garments supplied against official orders shall be returned to the contractor to be altered to the complete satisfaction of the Ordering Officer, at the contractor's expense, including forwarding charges each way.

(434/216/98.)

(This Order will be reprinted for posting on Notice Boards.)

406.

CONTRACTS FOR SUPPLY OF W.R.A.N.S. RATINGS' MADE-TO-MEASURE JACKETS AND SKIRTS.

Contracts have been arranged in Melbourne, Sydney, Brisbane, Adelaide, Perth, and Hobart for the supply of W.R.A.N.S. ratings' made-to-measure jackets and skirts for the period ending 28th February, 1945.

2. The contracts have been arranged for the convenience of W.R.A.N.S. ratings who wish to purchase made-to-measure garments and particular attention is invited to the conditions set out in paragraph 5 (d). Ratings should insist on contractors observing the conditions, which provide for at least one try-on in the basted or unfinished condition, and a final try-on in the finished state, in order to ensure satisfactory fit.

3. The names and addresses of the contractors are:—

Melbourne.—David Lack Pty. Ltd., Finlay's Buildings, corner Little Lonsdale and Elizabeth streets.

Sydney.—David Jones Ltd., Marlborough-street, Surry Hills.

Brisbane.—Chas. Gilbert and Co., 26-32 Queen-street.

Adelaide.—Coultas and Sons, Synagogue-place, off Rundle-street.

Perth.—National Clothing Co. (1939) Ltd., 40 King-street.

Hobart.—Garretts Pty. Ltd., 102 Bathurst-street.

4. The prices for the supply of uniforms are as follow and are inclusive of the cost of all materials:—

	Jacket, Double-breasted, Diagonal Serge, With Horn Buttons.	Skirt, Diagonal Serge.	Suit.
	£ s. d.	£ s. d.	£ s. d.
Melbourne contract	2 9 3	1 4 0	3 13 3
Sydney contract	2 13 1	0 18 8	3 11 9
Brisbane contract	2 18 0	1 10 5	4 8 5
Adelaide contract	3 10 3	1 0 6	4 10 9
*Perth contract	3 1 9	1 5 10	4 7 7
Hobart contract	2 19 0	1 4 5	4 3 5

* All garments under the Perth contract must be paid for in cash. Allotments will not be accepted.

5. The conditions of the contract are as follows:—

- (a) When ordering garments, the rating must present to the contractor a written authority signed by the applicant's Commanding Officer, or alternatively by a Senior Executive Officer and countersigned by the Accountant Officer, where one is borne. Such authority is to state the rating's name, official number, rating and establishment in which serving, and must specify in detail the articles and quantities thereof authorized to be purchased. Unless such an authority containing full details is presented, the order will not be accepted.
- (b) With the exception of the contractor at Perth, the rating may declare an allotment in favour of the contractor to pay for garments ordered or may pay cash whichever is desired. In the case of The National Clothing Co. Ltd., Perth, all garments ordered are to be paid for in cash.
- (c) The rating shall sign the order book of the contractor when placing order and shall state in writing in what manner she intends to pay for garments ordered. She shall make an initial payment of at least five shillings.
- (d) The garments ordered shall be made by the contractor to the measurement of the rating and shall be tried on at the contractor's premises at least once in the basted or unfinished condition and again in the finished state.
- (e) The garments shall be made to the complete satisfaction of the rating, but shall conform to Service requirements and specifications held by the contractor.
- (f) Completion of garments shall be effected within at least fourteen days from date of measurement of the rating or as otherwise arranged by mutual consent between the rating and the contractor, the delivery period to be subject to the rating attending for "try-on" on the date specified by the contractor.
- (g) Delivery of garments shall be taken at the contractor's premises or otherwise at the rating's expense.

6. In addition to the supply of personal requirements of made-to-measure garments, the contract provides for the supply of garments against official orders in circumstances where this may be necessary. In these circumstances, the following conditions shall apply:—

- (a) Orders shall be placed by Accountant Officer on Treasury Form 21 accompanied by properly completed self-measurement form (if ratings are unable to attend for measurement) and Form N.A.4.
- (b) Garments shall be completed within fourteen days of receipt by the contractor of the official order and delivered by parcels post to the address shown thereon, postal charges being to the account of the ship or establishment concerned.
- (c) Unsatisfactory garments supplied against official orders shall be returned to the contractor to be altered to the complete satisfaction of the Ordering Officer, at the contractor's expense, including forwarding charges each way.

(434/216/98.)

(This Order will be reprinted for posting on Notice Boards.)

407.

SUPPLY OF OFFICERS' UNIFORMS INCLUDING UNIFORMS FOR R.A.N. NURSES AND W.R.A.N.S. OFFICERS.

The prices for the supply of Naval Officers' uniforms including uniforms for R.A.N. Nurses and W.R.A.N.S. Officers referred to in Navy Orders 169, 222, and 330 of 1943 have been revised, operative from 1st June, 1944. The revised prices are shown in the appendix to this Order.

2. It will be observed that provision is made for the supply to R.A.N. Officers, who may require it, of Greatcoats made of Cloth No. 3 (using metallic gold lace) as an alternative to Beaver Cloth.

3. It will be further observed that prices have been included for uniforms for Warrant Officers and Commissioned Officers from Warrant Rank of the Paymaster, Schoolmaster, &c., Branches.

4. The following outfitters have agreed to operate under the Agreement:—

Melbourne.

Snows Men's Wear Ltd., Flinders-street.
Leviathan Ltd., corner Swanston and Bourke streets.
*Ince Bros., 166 Swanston-street.
*Myer Emporium Ltd., Bourke-street.

Sydney.

Anthony Hordern and Sons Ltd., Brickfield Hill.
F. Freeman and Sons, Smith-street, Surry Hills.
Vereys Ltd., King-street.

Adelaide.

*The Myer Emporium (S.A.) Ltd., Rundle-street.

Hobart.

J. Bidencope and Sons Pty. Ltd., Murray-street.

Perth.

The National Clothing Co. Ltd., 40 King-street.

Brisbane.

Rothwells Outfitting Ltd., Edward-street.

Fred Ryder Pty., 154 Queen-street.

* R.A.N. Nurses' and W.R.A.N.S. Officers' uniforms not included.

5. All officers mobilized for service are to be furnished with this information.

APPENDIX.

A.—PRICE LIST OF R.A.N. OFFICERS' UNIFORMS MADE UP BY PRIVATE OUTFITTERS.

(i) *Detachable Shoulder Straps, Greatcoats, White Mess Jackets, White Tunics and Trousers.*

Rank.	Detachable Shoulder Straps, Blue Cloth.	Greatcoat Blue Beaver Cloth (With Shoulder Straps).	Greatcoat Cloth Blue No. 3 (With Shoulder Straps).
	£ s. d.	£ s. d.	£ s. d.
Warrant Officer	0 16 6	7 17 9	6 12 0
Paymaster (etc.) Warrant Officer	0 18 0	7 19 3	6 13 6
Commissioned Officer from Warrant Rank	0 19 9	8 1 0	6 15 3
Paymaster (etc.) Commissioned Officer from Warrant Rank	1 1 3	8 2 6	6 16 9
Midshipman	7 6 6	6 0 6
Midshipman (E) and Paymaster Midshipman	0 8 3	7 9 6	6 3 6
Sub-Lieutenant	0 19 9	8 1 0	6 15 3
Engineer Sub-Lieutenant, and all other Officers of equivalent rank, with distinguishing cloth between lace	1 1 3	8 2 6	6 16 9
Lieutenant	1 6 3	8 7 6	7 1 6
Engineer Lieutenant, etc.	1 7 6	8 8 9	7 3 0
Lieutenant-Commander	1 13 0	8 14 3	7 8 6
Engineer Lieutenant-Commander, etc.	1 14 6	8 15 9	7 10 0
Commander	1 19 9	9 1 3	7 15 3
Engineer Commander, etc.	2 1 6	9 2 9	7 17 0
Captain	2 7 9	9 9 0	8 3 0
Engineer Captain, etc.	2 9 3	9 10 9	8 5 0
Mess Jacket, White Drill, with buttons	1 11 6
.. .. . without buttons	1 7 6
Waistcoat, white marcella, with buttons	1 15 3
.. .. . without buttons	1 13 6
Tunic, white drill, with buttons	1 7 9
.. .. . without buttons	1 4 6
Trousers, white drill	1 3 3

(ii) *Jackets, Waistcoats, and Trousers, Using Cloth for Officers' Uniforms.*

Rank.	Undress Jacket.	Mess Jacket.
	£ s. d.	£ s. d.
Warrant Officer	5 2 3	4 8 9
Paymaster (etc.) Warrant Officer	5 5 6	4 12 0
Commissioned Officer from Warrant Rank	5 7 6	4 14 0
Paymaster (etc.) Commissioned Officer from Warrant Rank	5 10 9	4 17 0
Midshipman	4 6 3	3 12 9
Midshipman (E) and Paymaster Midshipman	4 12 0	3 18 3
Sub-Lieutenant	5 7 6	4 14 0
Engineer Sub-Lieutenant and all other Officers of equivalent rank with distinguishing cloth between lace	5 10 9	4 17 0
Lieutenant	5 14 0	5 0 6
Engineer Lieutenant, etc.	5 16 9	5 3 3
Lieutenant-Commander	5 18 6	5 5 0
Engineer Lieutenant-Commander, etc.	6 1 6	5 8 0
Commander	6 1 6	5 8 0
Engineer Commander, etc.	6 3 6	5 9 9
Captain	6 7 6	5 14 0
Engineer Captain, etc.	6 10 6	5 17 0

Mess Waistcoat	} All Officers {	£ s. d.
Waistcoat		1 17 3
Trousers, laced for all ranks below Commodore, 1st class		1 5 0
Trousers, plain		5 19 3
		1 13 9

(iii) *Jackets, Waistcoats, and Trousers, using Light-weight Blue Serge.*

Rank.	Undress Jacket.	
	£ s. d.	
Warrant Officer	4 16 3	
Paymaster (etc.) Warrant Officer	4 19 3	
Commissioned Officer from Warrant Rank	5 1 6	
Paymaster (etc.) Commissioned Officer from Warrant Rank	5 4 6	
Midshipman	4 0 3	
Midshipman (E) and Paymaster Midshipman	4 5 9	
Sub-Lieutenant	5 1 6	
Engineer Sub-Lieutenant and all other Officers of equivalent rank, with distinguishing cloth between lace	5 4 6	
Lieutenant	5 8 0	
Engineer Lieutenant, etc.	5 10 9	
Lieutenant-Commander	5 12 6	
Engineer Lieutenant-Commander, etc.	5 15 6	
Commander	5 15 6	
Engineer Commander, etc.	5 17 3	
Captain	6 1 6	
Engineer Captain, etc.	6 4 6	
Waistcoat	} All Officers {	£ s. d.
Trousers		1 4 0
		1 9 3

(iv) *Jackets, Waistcoats, and Trousers, Using Diagonal Serge.*

Rank.	Undress Jacket.	
	£	s. d.
Warrant Officer	4	12 3
Paymaster (etc.) Warrant Officer	4	15 6
Commissioned Officer from Warrant Rank	4	17 6
Paymaster (etc.) Commissioned Officer from Warrant Rank	5	0 9
Midshipman	3	16 6
Midshipman (E) and Paymaster Midshipman	4	2 0
Sub-Lieutenant	4	17 6
Engineer Sub-Lieutenant and all other Officers of equivalent rank with distinguishing cloth between lace	5	0 9
Lieutenant	5	4 0
Engineer Lieutenant, etc.	5	7 0
Lieutenant-Commander	5	8 9
Engineer Lieutenant-Commander, etc.	5	11 6
Commander	5	11 6
Engineer Commander, etc.	5	13 6
Captain	5	17 9
Engineer Captain, etc.	6	0 6
Waistcoat	1	2 9
Trousers	1	6 6

B—PRICE LIST OF R.A.N.R. (S), R.A.N.V.R., AND R.A.N.R. OFFICERS UNIFORMS MADE UP BY PRIVATE OUTFITTERS.

(i) *Detachable Shoulder Straps, Greatcoats, Tunics, Waistcoats, and Trousers.*

Rank.	Detachable Shoulder Straps, Cloth, Blue and Non-Metallic Gold Lace.		Greatcoat, No. 3 Cloth, Blue, with Shoulder Straps and Non-Metallic Gold Lace.	
	R.A.N.R. (S).	R.A.N.V.R. and R.A.N.R.	R.A.N.R. (S).	R.A.N.V.R. and R.A.N.R.
	£ s. d.	£ s. d.	£ s. d.	£ s. d.
Midshipman			6	0 6
Warrant Officer	0	17 6	6	12 9
Paymaster (etc.) Warrant Officer	0	19 0	6	14 3
Commissioned Officer from Warrant Rank	0	17 6	6	12 9
Paymaster (etc.) Commissioned Officer from Warrant Rank	0	19 0	6	14 3
Sub-Lieutenant	0	17 6	6	12 9
Engineer Sub-Lieutenant and all other Officers of equivalent rank, with distinguishing cloth between lace	0	19 0	6	14 3
Lieutenant	1	3 9	6	19 0
Engineer Lieutenant, etc.	1	5 6	7	0 9
Lieutenant-Commander	1	10 9	7	5 9
Engineer Lieutenant-Commander, etc.	1	11 6	7	6 9
Commander	1	16 0	7	11 3
Engineer Commander, etc.	1	17 9	7	13 0
Captain	2	2 0	7	17 0
Engineer Captain, etc.	2	3 6	7	18 9
Tunic, white drill, with buttons			1	7 9
" " " without buttons			1	4 6
Waistcoat, cloth for Officers' uniforms			1	5 0
Trousers, cloth for Officers' uniforms			1	13 9
" " white drill			1	3 3

(ii) *Jackets, Using Cloth for Officers' Uniforms and Non-Metallic Gold Lace.*

Rank.	Undress Jacket.	
	R.A.N.R. (S).	R.A.N.V.R. and R.A.N.R.
	£ s. d.	£ s. d.
Midshipman	4	6 3
Warrant Officer	5	5 0
Paymaster (etc.) Warrant Officer	5	8 3
Commissioned Officer from Warrant Rank	5	5 0
Paymaster (etc.) Commissioned Officer from Warrant Rank	5	8 3
Sub-Lieutenant	5	5 0
Engineer Sub-Lieutenant and all other Officers of equivalent rank, with distinguishing cloth between lace	5	8 3
Lieutenant	5	11 3
Engineer Lieutenant, etc.	5	15 6
Lieutenant-Commander	5	15 6
Engineer Lieutenant-Commander, etc.	5	17 3
Commander	5	17 3
Engineer Commander, etc.	6	0 6
Captain	6	3 9
Engineer Captain, etc.	6	6 9

(iii) *Jackets, Waistcoats, and Trousers, Using Lightweight Serge and Non-Metallic Gold Lace.*

Rank.	Undress Jacket.	
	R.A.N.R. (S).	R.A.N.V.R. and R.A.N.R.
	£ s. d.	£ s. d.
Warrant Officer	4	19 0
Paymaster (etc.) Warrant Officer	5	2 3
Commissioned Officer from Warrant Rank	4	19 0
Paymaster (etc.) Commissioned Officer from Warrant Rank	5	2 3
Midshipman	4	0 3
Sub-Lieutenant	4	19 0
Engineer Sub-Lieutenant and all other Officers of equivalent rank, with distinguishing cloth between lace	5	2 3
Lieutenant	5	5 3
Engineer Lieutenant, etc.	5	9 6
Lieutenant-Commander	5	9 6
Engineer Lieutenant-Commander, etc.	5	11 3
Commander	5	11 3
Engineer Commander, etc.	5	14 6
Captain	5	17 9
Engineer Captain, etc.	6	0 6

Waistcoat					
Trousers					

(iv) *Jackets, Waistcoats, and Trousers, Using Diagonal Serge and Non-Metallic Gold Lace.*

Rank.	Undress Jacket.	
	R.A.N.R. (S).	R.A.N.V.R. and R.A.N.R.
Warrant Officer	£ s. d. 4 15 3	£ s. d. 4 5 9
Paymaster (etc.) Warrant Officer	4 18 6	4 9 0
Commissioned Officer from Warrant Rank	4 15 3	4 5 9
Paymaster (etc.) Commissioned Officer from Warrant Rank	4 18 6	4 9 0
Midshipman	3 16 6	3 16 6
Sub-Lieutenant	4 15 3	4 5 9
Engineer Sub-Lieutenant, and all other Officers of equivalent rank with distinguishing cloth between lace	4 18 6	4 9 0
Lieutenant	5 1 3	4 10 6
Engineer Lieutenant, etc.	5 5 6	4 13 6
Lieutenant-Commander	5 5 6	4 13 6
Engineer Lieutenant-Commander, etc.	5 7 6	4 16 6
Commander	5 7 6	4 16 6
Engineer Commander, etc.	5 10 9	4 18 3
Captain	5 13 9	5 0 0
Engineer Captain, etc.	5 16 9	5 2 9
Waistcoat	} All Officers	£ s. d. 1 2 9
Trousers		1 6 6

C.—PRICE LIST OF NAVAL CHAPLAINS' UNIFORMS MADE UP BY PRIVATE OUTFITTERS.

Item.	Cloth for Officers' Uniforms.	Serge Lightweight.	Serge Diagonal.
	£ s. d.	£ s. d.	£ s. d.
Undress jacket (ranking stripes not worn)	4 6 6	4 0 0	3 16 6
Trousers	1 13 9	1 9 3	1 6 6
Shoulder straps, plain, detachable	0 5 3
			£ s. d.
<i>Tunics or coats—made of white drill (including plain detachable shoulder straps made of cloth for Officers' Uniforms)</i>	1 14 6
<i>Trousers—white drill</i>	1 3 3

NOTE.—The foregoing prices do not cover provision of extension waistbands on trousers, or extra pockets, for which an additional charge may be made by the outfitter.

D.—PRICE LIST OF R.A.N. NURSES' AND W.R.A.N.S. OFFICERS' UNIFORMS MADE UP BY PRIVATE OUTFITTERS.

	Jacket.		Skirt.		Great-coat.	Capes.	
	Light-weight Serge.	Diagonal Serge.	Light-weight Serge.	Diagonal Serge.	Cloth No. 3 with Shoulder Straps.	Light-weight Serge.	Cloth No. 3.
	£ s. d.	£ s. d.	£ s. d.	£ s. d.	£ s. d.	£ s. d.	£ s. d.
R.A.N. Nurses ..	4 4 3	4 0 6	1 12 6	1 9 9	6 10 9	1 7 9	1 7 9
W.R.A.N.S. Officers ..	4 4 3	4 0 6	1 12 6	1 9 9	6 10 9

(434/215/1102.)

408.

CHOCOLATE AND CONFECTIONERY FOR NAVAL CANTEENS.

With reference to Navy Order 138 of 1944, it is notified that orders for chocolate and confectionery for Naval canteens are in future to be submitted for endorsement to an authorized officer of the Cocoa, Chocolate and Confectionery Committee in the State in which supplies are to be obtained, instead of the Deputy Director of Service Foodstuffs as hitherto.

2. Authorized officers of the committee are located at the office of the Deputy Director of War Organization of Industry in each State.

(668/204/90.)

409.

PRINTED FORMS.

The under-mentioned form has been introduced for use in the Royal Australian Navy in lieu of the corresponding Admiralty form.

2. Supplies will be issued, on demand, by the Superintending Naval Store Officer, Sydney, when stock of the existing form is exhausted:—
A.S.1323.—"Register of Secret and Confidential Documents."

(480/202/4583.)

410.

SECOND VICTORY LOAN.

The Government desires to emphasize that the success of the forthcoming Second Victory Loan is most important and desires that subscriptions should be made voluntarily by all sections of the community.

2. Approximately 750,000 of Australia's population are in the fighting Services and it is desired that every opportunity should be given to them to invest their savings in what is regarded as the best and safest investment in the Commonwealth.

3. Such money invested in War Loans not only bears the highest rate of interest now available but also helps the finances of the country. Bonds and War Savings Certificates are always readily negotiable and provide a valuable addition to deferred pay and other savings which may be required to assist in re-establishment in civil life after the war.

4. Bonds may be purchased outright or by instalments. Approval is given to the use of the allotment system where purchase of bonds by instalments is desired. Similarly, the purchase of War Savings Certificates may be made, *vide* Navy Order 59 of 1941. If you desire to subscribe ask the Accountant Officer for details.

5. The Second Victory Loan will be open in September.

(474/201/407.)

(This Order will be reprinted for posting on Notice Boards.)

RESTRICTED.(FOR OFFICIAL USE ONLY.)**Commonwealth Navy Orders.**

Navy Office, Melbourne,

8th August, 1944.

The following Orders, having been approved, are hereby promulgated for information and guidance, and necessary action.

By direction of the Naval Board,

J. P. Macandee

Secretary.

*The Commodore Commanding H.M.A. Squadron,
and Commanding Officers of H.M.A. Ships,
Officers in Charge of H.M.A. Naval
Establishments, and others concerned.*

TABLE OF CONTENTS.

No.	Subject.
411.	Security Classifications.
412.	Air Rescue Vessels—Allocation of Names.
413.	Accounts R.A.N. Destroyers and A.M.S. Attached to Eastern Fleet.
414.	Temporary Commissions—Coder Ratings.
415.	Pistols, Depth Charge, Mark VII—Restrictions on Issue.
416.	Boxes Ammunition C.222.
417.	M.L.'s—Telephone on Bridge.
418.	Anti-Malarial Measures for Operational Forces Destined for Service in Malarious Areas.
419.	Purchase of Naval Stores—Introduction of Form A.S.133z in R.A.N. Shore Establishments and Base Depots.
420.	W/S 1 and W/T 1—Granting of Non-Substantive Rate.
421.	Forms S.1148.
422.	Books and Forms.
	C.8288/44.

411.

SECURITY CLASSIFICATIONS.

The following secrecy categories have been approved for use in Service and other Commonwealth Departments:—

- (a) Top Secret.
- (b) Secret.
- (c) Confidential.
- (d) Restricted.

2. The use of "Top Secret", which replaces "Most Secret", is to be restricted to documents, information and material, the security aspect of which is paramount, and the unauthorized disclosure of which would cause exceptionally grave damage to the nation.

3. Documents, information or material, the unauthorized disclosure of which would endanger national security, cause serious injury to the interests or prestige of the nation, or any governmental activity thereof, or would be of great advantage to a foreign nation are to be classified **SECRET**.

4. Documents, information or material, the unauthorized disclosure of which, while not endangering the national security, would be prejudicial to the interests or prestige of the nation, any governmental activity, an individual, or would cause administrative embarrassment, or difficulty, or be of advantage to a foreign nation are to be classified **CONFIDENTIAL**.

5. Documents, information or material (other than **TOP SECRET**, **SECRET**, or **CONFIDENTIAL**) which should not be published or communicated to any one except of official purposes are to be classified **RESTRICTED**.

6. The chief changes in the new classifications are that the old "Confidential" has become "Restricted" and that a large proportion of the documents, etc., which were graded "Secret" under the previous classification becomes "Confidential" under the new grading.

(1866/2/154.)

412.

AIR SEA RESCUE VESSELS—ALLOCATION OF NAMES.

The following names have been allotted to new Air Sea Rescue Vessels arriving from the United States of America:—

No. C.26646	..	<i>Air Hope</i>
No. C.26647	..	<i>Air Faith</i>
No. C.26648	..	<i>Air Wave</i>
No. C.26668	..	<i>Air Spray</i>
No. C.26669	..	<i>Air Sense</i>
No. C.26670	..	<i>Air Bird</i>

AIR SEA RESCUE VESSELS—ALLOCATION OF NAMES—continued.

No. C.26671	..	<i>Air Cloud</i>
No. C.26677	..	<i>Air Host</i>
No. C.26678	..	<i>Air Speed</i>
No. C.26686	..	<i>Air Trial</i>
No. C.26687	..	<i>Air Mist</i>
No. C.26688	..	<i>Air Chief</i>
No. C.26689	..	<i>Air Master</i>
No. C.26690	..	<i>Air Save</i>
No. C.26691	..	<i>Air Mercy</i>
No. C.26692	..	<i>Air Sailor</i>
No. C.26696	..	<i>Air Rest</i>
No. C.26697	..	<i>Air Clan</i>
No. C.26698	..	<i>Air Watch</i>
No. C.36283	..	<i>Air View.</i>

(603/247/1775.)

418.

ACCOUNTS R.A.N. DESTROYERS AND A.M.S. ATTACHED TO EASTERN FLEET.

The accounts of R.A.N. Destroyers attached to the Eastern Fleet have been transferred to H.M.S. *Highflyer*.

2. The Accountant Officer (D), R.A.N. Eastern Fleet, is the Base Accountant Officer for H.M.A. Destroyers attached to the Eastern Fleet. Signals should be addressed direct to A.O. (D), R.A.N. E.F., and correspondence to—

Accountant Officer (D), R.A.N. Eastern Fleet,
H.M.S. *Highflyer*, C/o. British Fleet Mail.

3. The R.A.N. Accountant Officer, Colombo, is borne on the books of H.M.A.S. *Bathurst*. His office carries out the following functions:—

- (a) Base Accountant Office for A.M.S. vessels, Eastern Fleet, and R.A.N. Pool in H.M.S. *Lanka*;
- (b) Drafting office for R.A.N. Destroyers and A.M.S. vessels, Eastern Fleet, and R.A.N. Pool in H.M.S. *Lanka*;
- (c) R.A.N. Education Centre for Eastern Fleet.

His address for correspondence and signals is—

"R.A.N. Accountant Officer, Colombo."

4. Communications relating to personnel serving in R.A.N. manned ships of Eastern Fleet, whose actual ship is not known by ships or establishments in Australia, and private mail for ratings with no fixed ship address (e.g., ratings who have recently left Australia for disposal on arrival in R.A.N. Pool in H.M.S. *Lanka*) should be sent C/o. R.A.N. Accountant Officer, Colombo.

5. Navy Order 237 of 1944 is cancelled.

(1804/2/84.)

414.

TEMPORARY COMMISSIONS—CODER RATINGS.

The Naval Board have decided that coder ratings may now be considered for promotion to commissioned rank for cypher duties. Selected ratings will be promoted to Acting Sub-Lieutenant (Special Branch), R.A.N.V.R.

2. The following conditions will govern selection for and promotion to commissioned rank:—

- (a) C.W. Form 1 should be commenced for specially promising coder ratings at any time on or after completion of initial course at H.M.A. Signal School.
- (b) On completion of six months' service, if rating is still recommended, a report on Form C.W.1A should be rendered. It is considered that, at the end of this period, a rating should have acquired a general knowledge of the fundamental principles of communication organization and message handling.
- (c) Ratings recommended must be in possession of the Intermediate Certificate or have attained an equivalent educational standard.
- (d) Ratings recommended must be not less than nineteen and a half, nor more than thirty-five years of age.
- (e) Selected ratings will be drafted to Flinders Naval Depot for a course of approximately eight weeks, based on the standard of knowledge laid down for petty officer coder as set out on pages 23 and 24 of A.F.O. 885/1943. During this course, candidates will appear before a Selection Board with a view to final selection for a commission.
- (f) Ratings finally selected, will be promoted to Acting Sub-Lieutenant (Special Branch) R.A.N.V.R. and will then undergo a further one week's training, on completion of which officers will be given cyphering instruction at Navy Office.

3. Coders not selected for commissions will, if recommended by the Naval Officer-in-Charge, Flinders Naval Depot, be regarded as fully qualified by examination for leading coder. Similarly leading coders will, if recommended, be regarded as fully qualified by examination for petty officer coder.

4. Coder ratings now having this avenue for promotion to commissioned rank will no longer be eligible for Executive Branch commissions.

5. Navy Orders 412 and 582 of 1943 are hereby cancelled.

(568/202/907.)

(This Order will be reprinted for posting on Notice Boards.)

415.

PISTOLS, DEPTH CHARGE, MARK VII—RESTRICTION ON ISSUE.

The relaxation of straightness of primer tube referred to in Admiralty Fleet Order 1364/44 has not yet been applied to depth charges of local manufacture.

2. It is possible that depth charges Mark VII* (minol filled) received from overseas may incorporate this relaxation.

3. With reference to Confidential Commonwealth Navy Order 106 of 1944, ships authorized to carry minol filled depth charges are not to be issued with Mark VII (small flanged detonator carrier) pistols, and any pistols of this type at present on board these ships are to be exchanged for Mark VII* or VII** pistols at the first opportunity.

4. Mark VII pistols are not to be issued to H.M. Ships or to H.M.A. Ships proceeding overseas where Mark VII* depth charges manufactured with relaxed straightness of primer tube may be encountered.

5. Mark VII pistols are to be earmarked for first issue to ships other than those authorized to carry minol filled depth charges.

(471/205/2164.)

416.

BOXES AMMUNITION C.222.

Boxes Ammunition C.222 when stored in the open, or in exposed positions, are to be stacked upside down so as to prevent ingress of water.

(421/202/756.)

417.

M.L.'S—TELEPHONE ON BRIDGE.

It has been approved to fit a longer cable to the Mk. XI telephone handset on the bridge of M.L.'s. The cable is to be of sufficient length to enable the handset to be used on either port or starboard side of the bridge.

2. The work should be done by ship's staff, assisted as necessary by base staff. Demands for cable, electric, tinsel conductor, pattern 2504/A should quote this Order as authority.

3. The safe distance of sound power telephones from magnetic compasses is 4 feet. The longer lead will allow the telephone handset to be brought close to the magnetic compass, and Commanding Officers are to ensure that officers and ratings liable to use the telephone are warned not to bring it within the safe distance.

(603/294/756.)

418.

**ANTI-MALARIAL MEASURES FOR OPERATIONAL FORCES
DESTINED FOR SERVICE IN MALARIOUS AREAS.**

The instructions contained in paragraph 7 (b) of Navy Order 603 of 1943 as amended by Navy Order 240 of 1944, are cancelled, and the following sub-paragraph is to be substituted in place thereof:—

- (b) For all personnel proceeding to a malarious area, atebirin suppressive treatment is to commence one week prior to arrival in the malarious area, and is to consist for that period of 2 tablets of atebirin (0.2 gm.) once daily after food (the evening meal) with a drink of water. Subsequent suppressive treatment is to be carried out in accordance with paragraphs (c) and (d) of this Order.

(527/201/840.)

419.

**PURCHASE OF NAVAL STORES—INTRODUCTION OF FORM
A.S.133Z IN R.A.N. SHORE ESTABLISHMENTS AND BASE
DEPOTS.**

Navy Order 609 of 1943, paragraph 1, is to be amended by the insertion of "and H.M.A.S. *Lonsdale*", after "Flinders Naval Depot".

(480/202/4618.)

420.

**W/S 1 AND W/T 1—GRANTING OF ACTING NON-SUBSTANTIVE
RATE.**

Navy Order 239 of 1943, paragraph 3, is to be amended as follows:—

- (a) After the words "Flotilla Leaders .. 1 .. 1"
insert "N.O.I.C. New Guinea (Staff) .. 1 .. 1",

- (b) Delete the words "Port Moresby".

(463/205/3687.)

421.

FORMS S.1148.

Attention is called to A.F.O. 82A of 1942, which is reproduced below. This Order is to be adhered to in the R.A.N.

2. Ships which have not been carrying out this instruction previously are to commence serial numbers for 1944 from the receipt of this Order.

"A.F.O. 82A/42—FORMS S.1148—RENDERING.

In order to facilitate correspondence and prevent difficulty in connecting stores landed for examination with the corresponding Form S.1148, ships are to give each Form S.1148 rendered by them a serial number, irrespective of the suffixed letter to the form.

2. Serial numbers should commence at 1 on 1st January each year and be followed by the year itself, e.g., 1/42.

3. The serial number of the S.1148 should always be quoted when stores are landed for examination. The package should be stencilled with the serial number to facilitate rapid identification.

4. This Order is to be regarded as in force from 1st January, 1942, but in view of delays in receipt of Fleet Orders, ships should start serial numbers as from date of receipt of this Order."

(408/202/4624.)

422.

BOOKS AND FORMS.

First supplies of the under-mentioned publications have been distributed:—

B.R.317 (22).—Mining Drill Book—Minelaying Arrangements,
Coastal Force Craft.

(A.F.O. 1428/44.)
(571/202/1970.)

Errata No. 13 to B.R.359 and Form D.128D.—Establishment of
Naval Stores for Electrical and Torpedo Purposes and List
of Particulars.

(A.F.O. 5791/43.)
(571/202/1588.)

Errata No. 1 to B.R.362.—Establishment of Naval Stores for
Tugs attached to H.M. Dockyards.

(A.F.Os. 5418 and 6175/43.)
(571/202/1647.)

B.R.642 (F).—Summary of French Warships.

B.R.642 (R).—Summary of Russian Warships.

(A.F.Os. 6171/43 and 100/44.)
(571/202/1787.)

B.R.837.—Ozaki's Japanese-English Dictionary of Nautical
Terms.

B.R.838.—Ozaki's New English-Japanese Dictionary of Sea
Terms.

B.R.839.—Japanese-English-German Glossary of Electro Tech-
nical Terms, 1932.

B.R.840.—English-German-Japanese Glossary of Scientific Terms.

(A.F.O. 889/44.)
(571/202/1964.)

B.R.847/43 (late O.U. 6357 (2)).—Preliminary Pamphlet for 2 pdr. Mounting, Mark VII*P (Power Operated).

(A.F.O. 6291/43.)
(571/202/1951.)

B.R.849/43.—Handbook for the 15-inch B.L. Mark I Gun on Twin Marks I and I/N Mountings.

(A.F.Os. 5532/43 and 889/44.)
(571/202/1864.)

B.R.860 (5).—New Card 2A, Block Sketch Cards of War Vessels, Japan.

(A.F.O. 1428/44.)
(571/202/1921.)

B.R.869 (1).—Photographic Marking of Low Angle Gunnery Practices, 1943.

(A.F.Os. 363 and 889/44.)
(571/202/1917.)

B.R.873.—Notes on the Use of Cinema as an Aid to Training, 1943.

(A.F.Os. 792 and 1428/44.)
(571/202/1926.)

B.R.1009.—Handbook and Drill for Holman Projector Mark III, 1943.

(A.F.Os. 6174/43 and 889/44.)
(571/202/1940.)

Errata No. 13 to O.U.5365A.—Priced Vocabulary of Naval Armament Stores, Part I.

Errata No. 28 to O.U.5365B.—Priced Vocabulary of Naval Armament Stores, Part II.

Errata No. 13 to O.U.5365C.—Priced Vocabulary of Naval Armament Stores, Part III.

(A.F.O. 234/44.)
(571/203/2495.)

Know Australia.

(571/201/4247.)

2. Holders of B.R.253 "Handbook on the Hispano 20 m.m. Automatic Gun, Mark I, 1941" are to return their copies to the Superintending Naval Store Officer, Garden Island, Sydney.

(A.F.O. 1273/44.)
(571/202/1407.)

3. "Notes for Candidates for Leading Seaman and Petty Officer" is normally for issue on loan. Should it be necessary to effect issue on repayment, the sale price is 1s. 8d. S.A. No. 315 should be quoted in connection with such sales.

(571/202/1965.)

RESTRICTED.

(FOR OFFICIAL USE ONLY.)

Commonwealth Navy Orders.

Navy Office, Melbourne,
15th August, 1944.

The following Orders, having been approved, are hereby promulgated for information and guidance, and necessary action.

By direction of the Naval Board,

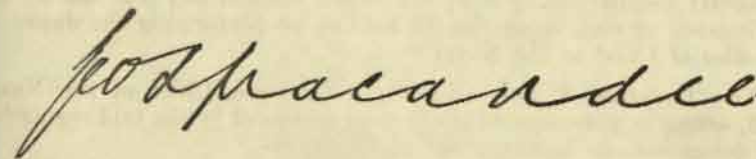

Secretary.

*The Commodore Commanding H.M.A. Squadron,
and Commanding Officers of H.M.A. Ships,
Officers in Charge of H.M.A. Naval
Establishments, and others concerned.*

TABLE OF CONTENTS.

No.	Subject.
423.	National Security (General) Regulations—Order made thereunder—Navigation and Anchor Lights Order (No. 4).
424.	Naval Officer-in-Charge, New Guinea, Transfer of Headquarters.
425.	Port Directors.
426.	Prisoners of War—Officers—Promotion.
427.	Confidential Reports on Officers.
428.	Diesel Generators—Exhaust Pipes.
429.	40 m.m. Bofors Mks. I and I*—Modification—Breech Casing, Right, Front.
430.	Gun Mounting 40 m.m. Bofors Mk. IIIA—Slewing Handles to be Fitted.
431.	40 m.m. Bofors Mks. I and I*—Modification—Cartridge Deflector.
432.	40 m.m. Bofors Mks. I and I*—Modification—Safety Lever Indicator Tally "Foot Pedal Held".
433.	40 m.m. Bofors Mks. I and I*—Modification—Left rear of Breech Casing.
434.	Searchers Steel Wire, Pattern 290.
435.	Small Arms Tools—Plates, Screw and Taps, S.A.
436.	Oxy-Acetylene Welding and Cutting Equipment.
437.	Damage to Mail Received at Milne Bay.

423.

**NATIONAL SECURITY (GENERAL) REGULATIONS—ORDER
MADE THEREUNDER.**

The following is promulgated for information:—

(*Commonwealth Gazette*, No. 155, dated 3rd August, 1944.)

COMMONWEALTH OF AUSTRALIA.

NATIONAL SECURITY (GENERAL) REGULATIONS.

Navigation and Anchor Lights Order (No. 4).

Whereas by Instrument of Delegation dated the twenty-first day of September, 1943, and published in the *Gazette* on the first day of October, 1943, the Minister delegated, *inter alia*, the powers and functions conferred upon him by regulation 45 of the National Security (General) Regulations to every officer who shall at any time during the continuance of such delegation be holding or performing the duties of the office of Chief of the Naval Staff:

Now therefore, I, Guy Charles Cecil Royle, Chief of the Naval Staff, acting in pursuance of the powers conferred by the said regulation and delegation, do hereby order as follows:—

1. This Order may be cited as the Navigation and Anchor Lights Order (No. 4).

2. Paragraph 4 of the Navigation and Anchor Lights Order is omitted and the following paragraph inserted in its stead:—

“4—(1) Subject to the succeeding provisions of this paragraph and to paragraphs 9 and 10 of this Order, navigation lights shall normally be dimmed to a visibility not exceeding:—

- (a) two miles in the case of the masthead steaming light and the side lights, and
- (b) one mile in the case of the stern light

and shall not be exhibited except for the purpose of avoiding collision or when exceptional circumstances make their use absolutely necessary.

(2) When navigating lights are exhibited for the purpose of avoiding collision, they shall be extinguished as soon as the danger of collision has passed.

(3) Navigation lights must be so arranged that they can be instantly shown when required to be exhibited.

(4) Dimmed navigation lights shall normally be exhibited—

- (a) within 5 miles of any port, when entering or leaving;
- (b) in Bass Strait between the meridians of 142 deg. 30 min. E. and 148 deg. 00 min. E.;
- (c) in St. Vincent and Spencer Gulfs when northward of latitude 36 deg. S. and north-east of a line joining Cape Borda and Cape Catastrophe;
- (d) inside the Great Barrier Reef between latitude 10 deg. 35 min. S. and 24 deg. 30 min. S.;
- (e) when proceeding on Inshore Routes between South Australian, Tasmanian and Queensland Ports; and

(f) when proceeding coastwise between Milne Bay and Cape Ward Hunt, and between Milne Bay and Goodenough Island.”

Dated this 21st day of July, 1944.

G. C. C. ROYLE,
Chief of the Naval Staff.

424.

**NAVAL OFFICER-IN-CHARGE, NEW GUINEA, TRANSFER OF
HEADQUARTERS.**

The headquarters of the Naval Officer-in-Charge, New Guinea, have been transferred to Madang.

- 2. The office of Commander “D” has been transferred to Madang.
- 3. Milne Bay will remain the main New Guinea refitting and stores base, and stores and correspondence dealing with such matters should, unless otherwise requested, be addressed to the Port Director, Milne Bay.
- 4. All other correspondence should be addressed to Madang.

(1084/2/88.)

425.

PORT DIRECTORS.

The Port Director at Cape Gloucester has been withdrawn.

- 2. R.A.N. Port Directorates are in operation only at Milne Bay, Oro Bay, Lae, Langemak Area, Saidor, and Madang.
- 3. Navy Orders 526 of 1943, 199 and 317 of 1944 are cancelled.

(1804/2/88.)

426.

PRISONERS OF WAR—OFFICERS—PROMOTION.

With reference to Navy Order 469 of 1943, paragraph (2) (a) (i), the following rules concerning the promotion of R.A.N., R.A.N.R. (S), R.A.N.R. and R.A.N.V.R. Officers whilst prisoners of war have been approved.

2. All promotions up to and including the rank or equivalent rank or relative rank of Lieutenant-Commander, of which the dates are pre-determined, and which are not subject to conditions, i.e., “automatic promotions,” will be conferred on the dates due.

3. Promotions of which the dates are pre-determined, but which are subject to qualifying conditions, such as to Lieutenant, Lieutenant (E), Surgeon Lieutenant-Commander, R.A.N., &c., will be conferred as if the qualifying conditions had been fulfilled, subject to a satisfactory record in each case.

4. Promotions which are normally made by selection, e.g., to Commander and above in the Permanent Naval Forces and the Royal Australian Naval Reserve (Sea-going) and to Lieutenant-Commander and above in the Royal Australian Naval Reserve and Royal Australian Naval Volunteer Reserve, will not be conferred while the officers are prisoners of war. The names of those who would otherwise have been promoted will be noted. On their return, their records will be examined and provided there are vacancies in the Establishment they will be promoted with effect from the earliest date at which it can be determined that they are fit and suitable for promotion, irrespective of whether they are then over the promotion zone or not. These promotions will not be antedated for seniority or pay.

5. In the case of Warrant Officers the following rules will apply:—

- (a) In those Branches where promotion to Commissioned Warrant Officer is made on a selective basis, officers will be promoted on attaining 12 years' seniority as a Warrant Officer subject to satisfactory record.
- (b) Where promotion to Commissioned Warrant Officer, or to Lieutenant from Commissioned Warrant Rank is determined by seniority, promotions will be made when due, subject to satisfactory record.
- (c) Promotions from Commissioned Warrant Officer to Lieutenant by selection and direct from Warrant Officer to Lieutenant will be dealt with as in paragraph 4 above.
- (d) Acting Warrant Officers will be confirmed after one year's service, including time as prisoner of war, subject to satisfactory record.

(556/201/1951.)

427.

CONFIDENTIAL REPORTS ON OFFICERS.

Reports on Naval Officers (Form S.206) are constantly being received at Navy Office from Commanding Officers in an incomplete condition, e.g., the occasion for the report, the capacity in which the Officer concerned is employed and date of report, are frequently omitted.

2. Reporting Officers are to ensure that adverse portions of reports, which require underlining in red, are communicated to the Officer reported upon.

3. In very many cases reports are not forwarded to the Senior Officer for his remarks in accordance with K.R. & A.I., Article 865, clause 4.

4. The selection of Officers to fill specific appointments, and higher ranks in the Service, largely depends on the accuracy with which these reports are drawn up.

(559/222/1278.)

428.

DIESEL GENERATORS—EXHAUST PIPES.

A report has been received from one of H.M.A. Ships concerning damage caused by the accumulation of rain water in the exhaust manifold of a diesel generator set.

2. In ships concerned, a short bend or cowl is to be fitted to the top of the exhaust outlet to prevent this occurrence.

3. In addition, a small drain cock is to be fitted to the lowest portion of the exhaust manifold on the engine. This cock should be left open whenever the engine is not running.

(603/282/954.)

429.

40 M.M. BOFORS MKS. I AND I*—MODIFICATION—BREECH CASING, RIGHT, FRONT.

The following modification has been approved in the R.A.N.:—

Gun	40 m.m. Bofors, Marks I and I*
Parts affected	Breech Casing, Right, Front.
Purpose	In order to differentiate quickly between a misfire and a mechanical stoppage.
Nature of modification	Paint letters "M" and "S" on casing as instructed below.
New parts required	Nil.
By whom to be done	Armament Depots, Ships' Staffs, Base Ordnance Staffs.
Degree of urgency	First opportunity.

2. Breech casings are to be marked by ships' or base staffs in the following manner:—

- (a) With the breech block open and held by the extractors, move the outer extractor releasing lever gently to the rear until it comes to rest (care being taken not to unhook the extractor from the breech block). Paint the letter "S" on the breech casing just above the end of the lever in this position.
- (b) With the breech block closed, move the outer extractor releasing lever fully to the rear. In this position, paint the letter "M" on the breech casing just above the end of the lever.
- (c) The letters are to be approximately $\frac{1}{4}$ inch high and painted on with good quality white paint.

3. *Instructions for Use.*—In the event of the gun failing to fire, the outer extractor releasing lever is to be moved gently to the rear. If it cannot be moved beyond the letter "S", the indication is that the breech is open and a mechanical stoppage has occurred. If it can be moved to the letter "M", the indication is that the breech is closed and that a misfire has occurred, due either to faulty ammunition or to a defective striker.

(490/212/1069.)

430.

GUN MOUNTING 40 M.M. BOFORS MK. IIIA—SLEWING HANDLES TO BE FITTED.

The following modification has been approved in the R.A.N.:—

It is intended to fit fast slewing handles to the rear of the Mark IIIA mountings of Australian Bofors where not at present fitted.

2. The first distribution will be made to Bases without demand and future requirements are to be demanded from the Gunmounting Depot, Garden Island, Sydney.

3. The fitting is to be carried out by Gunmounting Depot and Ordnance Base Staffs.

(490/212/1069.)

431.

40 M.M. BOFORS MKS. I AND I*—MODIFICATION—CARTRIDGE DEFLECTOR.

The following modification has been approved in the R.A.N. :—

Gun	40 m.m. Bofors, Marks I and I*
Part affected	Cartridge Deflector.
Purpose	To permit quick examination of the bore after a stoppage.
Nature of modification	One inch hole to be drilled in line with C/L of bore.
New parts required	Nil.
Drawing	In accordance with A.F.O. diagram 188/43.
By whom to be done	Armament Depots, Ships' Staffs, Base Ordnance Staffs.
Degree of urgency	First opportunity.

(490/212/1069.)

432.

40 M.M. BOFORS MKS. I AND I*—MODIFICATION—SAFETY LEVER INDICATOR TALLY "FOOT PEDAL HELD".

The following modification has been approved in the R.A.N. :—

Gun	40 m.m. Bofors, Marks I and I*
Part affected	Safety Lever Indicator Tally "Foot Pedal Held".
Purpose	To conform with R.N. procedure and drill.
Nature of modification	Replace existing Tally with new tally stamped "Trigger Held".
New parts required	Tallies should be made locally.
By whom to be done	Armament Depots, Ships' Staffs, or Base Ordnance Staffs.
Degree of urgency	First opportunity.

(490/212/1069.)

433.

40 M.M. BOFORS MKS. I AND I*—MODIFICATION—LEFT REAR OF BREECH CASING.

The following modification has been approved in the R.A.N. :—

Gun	40 m.m. Bofors, Mks. I and I*.
Part affected	Left rear of Breech Casing.
Purpose	To indicate the position of the "Misfire Stop" to enable the re-striking of a round which has apparently misfired.
By whom to be done	Armament Depots, Ships' Staffs, Base Ordnance Staffs.
Degree of urgency	First opportunity.
Nature of modification	A Misfire Stop line is to be painted on the left side of the casing in accordance with the following instructions :—

2. Bring the hand operating lever slowly to the rear, whilst observing the Breech Mechanism through the Bottom Cover. Immediately the check lever is observed to move over and retain the Inner Cocking Lever, stop moving the Hand Operating Lever, and hold it in this position. Scribe a line on the left side of the Breech Casing, as far as practicable from the axis of the Hand Operating Lever, to indicate the position of the upper edge of the Hand Operating Lever. The position of the line is to be checked by repeating the above operation. A white line $\frac{1}{4}$ inch wide and 3 inches long is then to be painted over the scribed line.

3. Should new Breech or Hand Operating mechanism components be subsequently fitted, the position of this line should be checked, and if necessary, corrected.

(490/212/1069.)

434.

SEARCHERS STEEL WIRE PATTERN 290.

Pattern 290 Searchers, Steel Wire, 16 feet, for cleaning boiler tubes, are not now required for use in H.M.A. Ships, and supply of this item will therefore be discontinued.

(524/203/1518.)

435.

SMALL ARMS TOOLS—PLATES, SCREW AND TAPS, S.A.

No further issues of Taps numbers 1 and 12 will be made in the R.A.N.

2. Consequently, die holes numbers 2, 3 and 4 will be included in one plate in future manufacture, the plate being designated Plate "A and B" (combined). Die hole No. 12 will be omitted from future manufacture of Plate "F".

(612/203/3051.)

436. **OXY-ACETYLENE WELDING AND CUTTING EQUIPMENT.**

Approval has been given to the addition of the under-mentioned equipment to the Lists of Special Allowances of Naval Stores for H.M.A. Destroyers, Frigates and the under-mentioned A.M.S. Vessels, for use in self-refitting and to effect "After-Action" repairs:—

Patt. No.	Description.	Quantity.	† A.M.S. Vessels.
..	Oxy-welding and Cutting Equipment (complete with Oxygen Regulator, Acetylene Regulator, Welding Blowpipe with tips, Cutting Blowpipe attachment with tips and two 25-ft. lengths of hose)	1 set	<i>Goulburn</i> <i>Bendigo</i> <i>Fremantle</i> <i>June</i> <i>Kalgoorlie</i> <i>Cootamundra</i>
..	Oxygen Gas	*4 bots.	<i>Geelong</i> <i>Warrnambool</i>
..	Acetylene Gas	*2 ,,	<i>Rockhampton</i> <i>Katoomba</i> <i>Townsville</i> <i>Broome</i> <i>Colac</i> <i>Latrobe</i> <i>Benalla</i> <i>Ararat</i> <i>Cowra</i> <i>Inverell</i> <i>Strahan</i>

NOTES.—* Minimum quantity to be carried by each vessel.

† It is not intended that each A.M.S. Vessel shall be issued with a set of this equipment, but only on the basis of approximately one to every three vessels.

2. Arrangements have been made for supply of the above-mentioned items to H.M.A. Ships concerned to complete to the above allowances, to be effected without demand, by the Superintending Naval Store Officer, Sydney.

(524/201/2567.)

437.

DAMAGE TO MAIL RECEIVED AT MILNE BAY.

The damaged condition in which articles of parcel mail have been received in New Guinea is causing concern, and a number of complaints has been received from recipients.

2. In many cases the wrappings have been insufficient to withstand the handling to which the packages are subject prior to delivery to New Guinea areas.

3. Personnel should therefore be instructed to warn their relatives and friends to ensure that parcels are firmly packed and strongly wrapped before despatch.

(443/201/1333.)

(This Order will be reprinted for posting on Notice Boards.)

By Authority: H. E. Daw, Government Printer, Melbourne.

RECEIVED

10 SEP 1944

438—449/44.

RESTRICTED.

(FOR OFFICIAL USE ONLY.)

Commonwealth Navy Orders.

Navy Office, Melbourne,
22nd August, 1944.

The following Orders, having been approved, are hereby promulgated for information and guidance and necessary action.

By direction of the Naval Board,

J. P. Macarandee
Secretary.

*The Commodore Commanding H.M.A. Squadron,
and Commanding Officers of H.M.A. Ships,
Officers in Charge of H.M.A. Naval
Establishments, and others concerned.*

TABLE OF CONTENTS.

No.	Subject.
438.	Examination of Sick Berth Staff—May, 1944—Results.
439.	Higher Educational Test—April, 1944—Results.
440.	Service Certificates and Pay Accounts—H.M.A. Ships Attached to Eastern Fleet.
441.	Correspondence—H.M.A. Radar School.
442.	Gun Mountings 2 Pdr. Mark XIV—Replacement in "B" Type M.L's by 3 Pdr. Mark V and 2 Pdr. Mark VIII*.
443.	Guns and Gunmountings—Reports of Stock and Transactions.
444.	Special Victualling Assistance to Seagoing Ships Victualled on the Repayment System and Operating in Advanced Areas.
445.	Emergency Rations for Aircraft Operating from H.M.A. Ships.
446.	Service System Canteens in Frigates and A.M.S. Vessels.
447.	Treatment of Serving Members of the Forces at Repatriation Out-Patient Clinic, St. Kilda-road, Melbourne.
448.	Leave Concession and Other Railway Travelling Warrants.
449.	Form A.M. 114z—Report of Seasickness.

EXAMINATION OF SICK BERTH STAFF—MAY, 1944—RESULTS.

The results obtained by candidates who passed in the examination for advancement in the Sick Berth Branch, held on 30th May, 1944, are as given hereunder:—

Examination Number.	Name.	Present Rating.	O.N.	Percentage of Marks obtained at Examination.				Approximate Average Percentage for (a) Written, and (b) Oral and Practical.	Where Serving at Time of Examination.
				Paper No. 1.	Paper No. 2.	Written (Average Percentage).	Oral and Practical.		
25	Nichol, J. H. ..	A/L.S.B.A.	B/3173	59	71	65	93	79	<i>Magnetic</i>
27	Rogash, F. D. ..	L.S.B.A.	PM/3034	75	77	76	71	73	<i>Kurunda</i>
42	Berger, S. C. ..	"	PM/2784	79	78	78.5	76	77	<i>Cerberus</i>
43	Tisdall, A. W. ..	"	PM/2992	58	63	60.5	79	70	<i>Cerberus</i>
46	Williams, F. R. ..	"	PM/2129	93	65	79	79	79	"
47	Berry, K. H. ..	"	PA/1368	73	54	63.5	77	70	"
49	Bell, T. R. ..	"	PM/2694	70	61	65.5	78	72	"
50	Grindlay, R. G. ..	"	PM/2147	91	72	81.5	72	77	"
53	Leverenz, A. ..	"	PA/2037	91	66	78.5	85	82	"
70	Howie, J. M. ..	A/L.S.B.A.	PA/1397	75	67	71	78	74	<i>Melville</i>
88	Tulley, M. P. M. ..	A/L.S.B.A.	F/2173	77	58	67.5	77	72	<i>Leeuwin</i>
		(ty)							
99	McGinley, R. H. S. ..	L.S.B.A. (ty)	23219	79	56	67.5	80	74	<i>Maitland</i>
100	Phillips, R. H. ..	L.S.B.A.	S/2932	62	80	71	69	70	<i>Rushcutter</i>
105	Kennedy, C. R. ..	"	S/3238	70	72	71	69	70	<i>Penguin</i>
126	Newton, E. C. R. ..	"	PM/2354	72	70	71	77	74	<i>Australia</i>
128	Jose, R. J. ..	"	PM/2406	78	84	81	75	78	<i>Swan</i>
132	Russell, J. ..	"	21981	65	81	73	76	74	<i>Ladava</i>
133	Ramsey, J. D. ..	"	S/2664	61	73	67	73	70	"
134	Kain, G. C. ..	"	22629	71	77	74	83	78	"
135	Munday, R. J. ..	"	PM/2413	73	71	72	79	75	"
144	Jay, O. ..	"	21696	60	72	66	74	70	<i>Kanimbla</i>
14	Williamson, K. R. ..	S.B.A.	H/1853	55	72	63.5	70	67	<i>Fremantle</i>
24	Betts, R. M. ..	"	B/4471	66	65	65.5	83	74	<i>Magnetic</i>
26	Robertson, W. G. ..	"	S/8133	64	48	56	71	63	<i>Hobart</i>
28	Hart, L. D. ..	"	23081	93	71	82	61	71	<i>Kurunda</i>
30	Tuxworth, J. E. ..	"	B/3553	88	69	78.5	61	70	"
38	Barlow, R. R. ..	"	PA/3424	80	79	79.5	79	79	<i>Cerberus</i>
40	Smart, J. T. ..	"	PA/3505	60	57	58.5	73	66	"
41	Andrews, R. J. ..	"	PA/3451	57	69	63	63	63	"
44	Cadee, K. T. ..	"	F/5024	61	49	55	74	64	"
48	Stanley, R. J. ..	"	22632	67	65	66	68	67	"
84	Robertson, M. J. ..	"	PM/3207	58	59	58.5	75	67	<i>Lonsdale</i>
89	McAlpine, D. J. S. ..	"	WR/1702	79	65	72	50	61	<i>Leeuwin</i>
90	McAlpine, P. S. ..	S.B.A.	WR/1701	72	51	61.5	60	61	"
92	Ball, J. E. ..	"	PM/3455	64	63	63.5	60	62	<i>Basilisk</i>
93	Kewell, L. A. ..	"	PA/1917	65	67	66	70	68	"
94	Teasdale, L. R. ..	"	S/6504	61	71	66	90	78	"
102	Wood, C. L. ..	"	S/3273	67	68	67.5	64	66	<i>Penguin</i>
125	Cattell, J. E. ..	"	B/3449	74	62	68	55	61	<i>Doomba</i>
136	Smith, S. N. ..	"	PA/2021	78	87	82.5	74	78	<i>Ladava</i>
137	Leary, V. L. ..	"	PM/2387	71	78	74.5	57	66	"
138	Clark, E. A. ..	"	PA/1464	51	65	58	62	60	"
143	Hucker, P. G. ..	"	S/3110	67	69	68	67	67	<i>Kanimbla</i>
145	Omond, F. M. ..	"	24988	50	68	59	70	64	<i>Moreton</i>

2. The marks obtained by candidates who failed have been communicated to the Commanding Officer of the ship or establishment in which the rating was serving at the time of the examination.

3. Papers from overseas vessels have, in some cases, not yet been received. If any examination papers should be forthcoming later, the results thereof will be published as soon as practicable.

4. The 30th May, 1944, is to be regarded as the basic date for the passing of this examination.

5. The original copies of Forms A.S. 1236 and A.S. 1237 have been completed and forwarded to the ships and establishments concerned. Duplicate copies have been forwarded to the Naval Officer-in-Charge, Flinders Naval Depot. The necessary notation should be made on the Service Certificates of candidates.

(This Order will be reprinted for posting on Notice Boards.)

HIGHER EDUCATIONAL TEST—APRIL, 1944—RESULTS.

The pass results obtained by candidates in the subjects taken by them in the Higher Educational Test held between the 11th and 14th April, 1944, are as given hereunder. Included in these results are the pass marks obtained by each candidate at previous examinations where such marks are higher than those obtained at the April, 1944, examination.

Name.	Rating.	Official No.	Where Serving at Time of Examination.	Papers.									Remarks.
				I.	IA.	II.	III.	IV.	VII.	VIIA.	VIII.	IX.	
				General Knowledge.	English for A/Sub-Lieu.	English History.	Geography.	Navigation.	Practical Mathematics.	Maths. for A/P/y. Sub-Lie.	Mech. engin.	Magnetism and Electricity.	
Scully, Edward J. ..	C.P.O. Cook ..	4041	<i>Australia</i> ..	67(z)	77	Qualified for Warrant Rank
Chapman, Donald A. ..	Ldg. Tel. ..	23490	<i>Cerberus</i>	64	59	Qualified for Warrant Rank
Dargin, Arthur ..	Petty Officer ..	20243	" ..	78	..	70(ii)	67(hh)	81(ee)	64(ee)	66(jj)	Qualified for Warrant Rank and H.E. Cert., 2nd Class
Dingwall, James ..	Ord. Seaman ..	PM/5982	" ..	67	
Furze, Frederick G. ..	Ldg. Tel. ..	PM/3281	"	75	69	
Hodgkinson, David W. ..	Radio Mech. ..	S/8978	"	66	60	..	64	58	
Hurst, Keith C. ..	Petty Officer ..	20510	" ..	61	
Marshall, Douglas A. ..	Petty Officer ..	20607	" ..	55(nn)	68	
Stevens, Harold V. ..	R.P.O. ..	20318	" ..	70	
Williamson, Rex N. ..	S.P.O. ..	NZ1438	"	92	..	61	..	
Goddard, George J. ..	Mech., 1st Class ..	19934	<i>Hobart</i> ..	67	67(ss)	..	83(rr)	..	92(tt)	78(qq)	Qualified for Warrant Rank and H.E. Cert., 2nd Class
Belcher, Allan C. ..	Writer ..	PM/5291	<i>Ladava</i> ..	80	68	
Brown, Lennon G. ..	Ldg. Writer ..	B/2174	"	63	
Hogg, Stanley G. ..	Writer ..	PM/5525	" ..	71	66	
McIntosh, John R. ..	E.R.A., 2nd Class ..	PM/870	" ..	77	56(rr)	..	60(ss)	..	55(rr)	..	H.E. Certificate, 2nd Class
Hare, John M. ..	P.O. Writer ..	23082	<i>Lonsdale</i> ..	80(w)	..	81	79	90(uu)	Qualified for Warrant Rank and H.E. Cert., 1st Class
Castle, Edgar W. ..	Writer ..	PA/3097	<i>Melville</i>	67	
Fisk, Thomas H. ..	Petty Officer ..	19948	" ..	64(vv)	79(vv)	64	69(vv)	Qualified for Warrant Rank and H.E. Cert., 2nd Class
Richards, Norman H. ..	P.O. Tel. ..	B/845	<i>Morston</i> ..	68	70	..	80	81	H.E. Certificate, 2nd Class
Morrison, Frederick G. ..	Supt., 3rd Class ..	21471	<i>Penguin</i> ..	62	76	
Neale, William ..	Able Seaman ..	S/5427	" ..	70	..	83	60	
Nolan, Francis B. ..	P.O. Writer ..	23407	" ..	83(qq)	..	78(qq)	75(qq)	..	62(qq)	83	Qualified for Warrant Rank and H.E. Cert., 1st Class
O'Sullivan, John W. ..	Motor Mech., 4th Class ..	26476	" ..	77	81	
Nicholls, Stanley ..	Able Seaman ..	PA/4145	<i>Shropshire</i>	75	77	
Potter, Edward T. ..	Telegraphist ..	F/2315	<i>Westralia</i>	57	78	
Eccleston, John T. ..	C.P.O. Writer (ty.) ..	20765	<i>R.A.N.A.O. Colombo</i> ..	68	78	Qualified for Warrant Rank

(z) Marks obtained at November, 1932, examination.
 (hh) Marks obtained at October, 1936, examination.
 (jj) Marks obtained at October, 1937, examination.
 (qq) Marks obtained at April, 1941, examination.
 (ss) Marks obtained at April, 1942, examination.
 (uu) Marks obtained at April, 1943, examination.

(ee) Marks obtained at March, 1935, examination.
 (ii) Marks obtained at April, 1937, examination.
 (nn) Marks obtained at October, 1939, examination.
 (rr) Marks obtained at October, 1941, examination.
 (tt) Marks obtained at October, 1942, examination.
 (vv) Marks obtained at October, 1943, examination.

Maximum marks in each subject—100.
 75 per cent. of total marks is considered a first-class pass.
 55 per cent. of total marks is considered a second-class pass.

2. The marks obtained by candidates in subjects in which they did not pass are not shown above. Should any candidate desire to be informed of these marks, he should make application to the Commanding Officer of the ship or establishment in which he is serving, who has been supplied with a statement of the full results obtained at the examination. Notation of the award of Higher Educational Certificates and Qualified for Warrant Rank (Q.W.R.) should be made on the Service Certificates of the ratings concerned.

(This Order will be reprinted for posting on Notice Boards.)

(465/204/670.)

440.

**SERVICE CERTIFICATES AND PAY ACCOUNTS—H.M.A. SHIPS
ATTACHED TO EASTERN FLEET.**

Paragraph 2 of Navy Order 57 of 1944 is cancelled.

2. The instructions contained in Navy Order 413 of 1944 are to apply to this correspondence.

(443/201/1256.)

441.

CORRESPONDENCE—H.M.A. RADAR SCHOOL.

Approval has been given for signals and correspondence on Radar technical, training and drafting matters, previously addressed to H.M.A.S. *Rushcutter*, to be addressed direct to the Officer-in-Charge, R.A.N. Station 284, Post Office, Watson's Bay, N.S.W.

(443/201/328.)

442.

**GUN MOUNTINGS 2 PDR. MARK XIV—REPLACEMENT IN "B"
TYPE M.L'S BY 3 PDR. MARK V AND 2 PDR. MARK VIII*.**

The provisions of Admiralty Fleet Order 2349/44 will not be implemented in the R.A.N.

2. 2 pdr. Mark XIV mountings are being replaced by single Bofors Mk. IIIA mountings in Fairmile M.L's of the R.A.N. in accordance with Naval Board message 030207/May, 1944.

(490/208/678.)

443.

**GUNS AND GUNMOUNTINGS—REPORTS OF STOCK AND
TRANSACTIONS.**

Future reports of issues and receipts of Gunmountings rendered in accordance with paragraph 4 of Navy Order 235 of 1942 are to include particulars of issues and receipts of the following equipment:—

- (i) Fuzes setting machines and receivers, showing Marks and Register Numbers.
- (ii) Gyro gun sights showing Marks and Register Numbers.
- (iii) Rangefinders, Heightfinders and their mountings showing type, size, and Register Numbers.

2. The first report rendered in accordance with this Order is to show all of these items available at the date of report.

(490/201/1652.)

444.

**SPECIAL VICTUALLING ASSISTANCE TO SEAGOING SHIPS
VICTUALLED ON THE REPAYMENT SYSTEM AND
OPERATING IN ADVANCED AREAS.**

In confirmation of Navy Office Message 051151, July, 1944, the approved revised procedure in regard to messing arrangements of the above-mentioned ships is promulgated hereunder for ready reference and guidance.

2. In order that messes of repayment ships in advanced areas may be enabled in future to victual themselves to the approximate standard of meals in general mess ships without cost to the individual messes concerned, it is approved, as from 1st July, 1944, and until further notice, that all such repayment messes in ships, whilst operating from Australia in waters North of 20 degrees South latitude, may draw ship's provisions up to 5d. per head per diem in excess of the current victualling allowance of 1s. 9d. without recovery being effected from those messes monthly in the normal manner.

3. The express purpose of this improvement in messing conditions of repayment ships is to enable messes concerned to victual themselves daily to the general mess standard without cost to themselves, and Commanding Officers of ships affected are to ensure that the required accounting procedure detailed in paragraph 8 below is closely followed. In this connection it is to be specially noted by all concerned that foodstuffs drawn by messes in excess of the victualling allowance under this authority are to be restricted to immediate day to day requirements, and are not to be accumulated for future consumption or used for any purpose other than for which they are intended.

4. The supplementary Fixed Issuing Price List for Provisions contained in Navy Order 564 of 1943 is not to apply to repayment ships whilst the messing assistance provided in paragraph 2 above is applicable.

5. Accumulated debit balances owing on 30th June, 1944, by individual messes in repayment ships, and incurred in areas indicated in paragraph 2 above, are, after deduction of any accumulated credits due to those messes, to remain unadjusted pending further advice. A statement of all such unadjusted balances for each month to 30th June is to be forwarded to the Director of Victualling as soon as possible by Accountant Officers of parent ships in order that further consideration may be given to the question of settlement. Meanwhile all accounts to 30th June should be closed and rendered into office without effecting recovery from messes.

6. The provisions of paragraph 2 are to apply to officers' messes in repayment ships, but not in the case of paragraph 5.

7. The general instructions concerning rationed foodstuffs as contained in Navy Order 265 of 1944, are in no way affected by the provisions of this Order.

8. In regard to paragraphs 2 and 3 above, for accounting purposes the current victualling allowance of 1s. 9d. is to be entered at the head of the appropriate column in Form A.S.462z and the following procedure observed:—

- (i) As far as it is practicable, provisions are to be issued daily and confined to the actual daily requirements.
- (ii) As provided in Navy Order 265 of 1944, issues of canned provisions should, as far as is possible, be confined to occasions when fresh items are not available.
- (iii) At the end of the month, the total value of provisions issued is to be transferred to the applicable column for each mess in Form A.S.462z and the mess balance arrived at in the usual manner.
- (iv) When the total value of provisions issued exceeds an amount arrived at by multiplying the sum of 2s. 2d. by the numbers victualled for the month or portion of month concerned, recovery is to be effected of the excess amount only.
- (v) As hitherto, mess savings paid in cash are to be confined to the normal victualling allowance of 1s. 9d. per diem, no cash payment being applicable in respect of the special messing assistance of 5d. per diem referred to in paragraph 2.
- (vi) Any portion of the special messing assistance of 5d. per diem not utilized during a month is not transferable to an ensuing month.
- (vii) Paragraph (f), as follows, is to be added to Certificate "D" of Form A.S.462z by the Commanding Officer in respect of paragraph 2 above:—

(f) the special messing assistance referred to in paragraph 2 of Navy Order 444 of 1944, applied to H.M.A. Ship under my command during this month from..... to, and the quantities of provisions issued during that period, were to meet immediate day to day requirements.

(508/201/1690.)

(This Order will be reprinted for posting on Notice Boards.)

445.

EMERGENCY RATIONS FOR AIRCRAFT OPERATING FROM H.M.A. SHIPS.

With reference to Navy Order 67 of 1944, supplies of the 35 oz. hermetically sealed water cans referred to in paragraphs 1 and 3 thereof are not available from Naval Victualling Depots owing to amendments being made in the type of water container to be supplied.

2. Until such time as supplies of the revised type of water can are available from Naval stocks, requirements should be obtained from R.A.A.F. sources.

(668/201/2624.)

446.

SERVICE SYSTEM CANTEENS IN FRIGATES AND A.M.S. VESSELS.

Advances of sums not exceeding £2 per head of complement, excluding commissioned officers, may be made by Naval Officers-in-Charge to the Commissioning Officers of Frigates and A.M.S. Vessels, on commissioning, for the establishment of canteens on the Ordinary Service System.

2. Frigates and A.M.S. Vessels already in commission which received, on commissioning, reduced advances of £100 and £50 respectively may draw supplementary advances, if necessary, provided that the total advances received by any ship are not to exceed the maximum amount specified in paragraph 1 above.

3. All advances and supplementary advances are to be made in accordance with Naval Account Regulations and Instructions, Article 61, and are to be reported immediately to Navy Office.

(427/201/876.)

447.

TREATMENT OF SERVING MEMBERS OF THE FORCES AT REPATRIATION OUT-PATIENT CLINIC, ST. KILDA-ROAD, MELBOURNE.

The Repatriation Commission has notified that, owing to the increased demand on their facilities, treatment can no longer be afforded to serving members of the Forces at the Repatriation Out-patient Clinic, St. Kilda-road, Melbourne.

2. In future, therefore, it will be necessary to obtain advice and treatment in Melbourne from private practitioners with whom the Navy has agreements, or through facilities afforded by the Army or R.A.A.F.

3. If any difficulty is experienced in obtaining the use of these facilities, application should be made to the Senior Medical Officer, H.M.A.S. *Lonsdale* or to the Director of Naval Medical Services.

(527/211/2062.)

448.

LEAVE CONCESSION AND OTHER RAILWAY TRAVELLING WARRANTS.

As indicated in Naval Financial Regulations and Instructions, Article 170, clause 8, the cost of a sleeping berth on the Trans-Australian Railway only is a Departmental liability in respect of members travelling on leave concession warrants. Further, as leave allowance is not credited to members travelling on the East-West route between Perth and Adelaide (Naval Financial Regulations and Instructions, Article 147), the supply of meals between those points is a liability of the Department.

2. Leave concession warrants, therefore, should be prepared in accordance with the provisions of Naval Financial Regulations and Instructions, Article 170, with particular attention to clauses 8 and 9, which indicate that sleepers and/or seats should not be provided for, except in circumstances specifically set forth therein.

As regards travel on leave concession warrants on the Trans-Australian and Kalgoorlie-Perth Sections of the East-West Railway, the following procedure should be observed in future:—

- (a) No provision to be made in the rail warrant for meals, sleepers, or seats.
- (b) A separate warrant to be prepared to cover provision, at Departmental expense, of meals throughout and sleeper on the Trans-Australian Section only.
- (c) Members to be informed that costs of additional amenities are their own liability.

3. Attention is drawn to Naval Financial Regulations and Instructions, Article 170, clause 20, which provides that duty warrants used in emergency for leave concession travelling should be clearly marked "Travelling Concession." Action should be taken, however, to ensure that the special (yellow) leave concession warrant forms will be available for use.

4. With reference to Naval Account Regulations and Instructions, Article 324 (b), unused or part-used tickets obtained on Departmental warrants and forwarded to Navy Office by H.M.A. Ships for necessary adjustment should be accompanied by full details of the issue, i.e., book and warrant number, full name, rank or rating and official number of member concerned, together with the date and office or ship of issue, where available.

(632/202/1027.)

449.

FORM A.M.114z—REPORT OF SEASICKNESS.

The above-mentioned form has been established for use in the Royal Australia Navy, and is to be completed as the certificate required by paragraph 1 (a) of Confidential Commonwealth Navy Order 137 of 1943, and forwarded to the Commanding Officer of the depot to which the member suffering from seasickness is discharged.

2. In the event of the member being surveyed, Form A.M.114z is to be forwarded to Navy Office with the report of the Medical Board of Survey.

3. First supply will be made, without demand, by the Medical and Dental Supply Officer, Sydney.

(527/201/880.)

RESTRICTED.(FOR OFFICIAL USE ONLY.)

Commonwealth Navy Orders.

Navy Office, Melbourne,
29th August, 1944.

The following Orders, having been approved, are hereby promulgated for information and guidance, and necessary action.

By direction of the Naval Board,

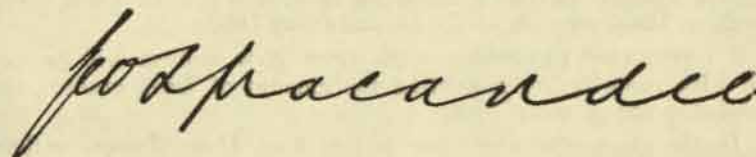

Secretary.

*The Commodore Commanding H.M.A. Squadron,
and Commanding Officers of H.M.A. Ships,
Officers in Charge of H.M.A. Naval
Establishments, and others concerned.*

TABLE OF CONTENTS.

No.	Subject.
450.	Despatch of Personnel to Ships and Establishments in New Guinea Area.
451.	Course and Examination for Chief Ordnance Artificer.
452.	Retention of Acting Higher Rank.
453.	Income Tax.
454.	Ventilation of H.M.A. Vessels.
455.	H.D.M.L.'s ex U.S.A.—Fitting of Twin Vickers .303-in. Mountings—Alterations and Additions.
456.	Stores Transferred from the U.S. Navy to the R.A.N.
457.	Table Cloths and Mats.
458.	Supply of Officers' Uniforms—Inclusion of Additional Outfitter for R.A.N. Nurses and W.E.A.N.S. Officers.
459.	Refund of Flour Tax.
460.	Southern Cross Club, New York City, U.S.A.
461.	Ratings' Uniform—Deviation from Standard Patterns.
462.	Signature of Naval Board Documents.
463.	Corrigendum.

450.

**DESPATCH OF PERSONNEL TO SHIPS AND ESTABLISHMENTS
IN NEW GUINEA AREA.**

Personnel who have been serving ashore for an extended period in other than Northern Areas (as defined in Navy Order 410 of 1942) are to be despatched forthwith, on receipt of appointment or draft note, if they have had leave during the preceding six months.

2. Personnel as in paragraph 1 who have not had leave during the previous six months may be granted leave due, if requested, before being despatched, unless the appointment or draft is of particular urgency as indicated by the Naval Board or Naval Officer-in-Charge, New Guinea, when they should proceed as directed. For this purpose "leave due" is to be calculated on the basis of two days per month for the current leave year.

3. Personnel who have returned from sea service within the preceding six months may be granted up to fourteen days' leave before despatch, at the discretion of the Commanding Officer.

4. All personnel proceeding south from New Guinea will be furnished with route orders indicating the amount of leave granted and intended disposal on completion.

5. In the absence of any other instructions, Home Depots without further enquiry should, on completion of leave, arrange for personnel sent south for leave to return to New Guinea by most expeditious means.

6. Requests for extension of leave will only be considered if recommended by the respective Naval Officer-in-Charge, after investigation and on the grounds indicated in C.A.F.O. 312/43, or equally serious reasons, which the Naval Officer-in-Charge considers justify such a recommendation. Extension of leave to be married within a few days of expiry of leave is not considered justifiable.

(520/201/1199.)

451.

COURSE AND EXAMINATION FOR CHIEF ORDNANCE ARTIFICER.

Commanding Officers of H.M.A. Ships and Establishments should forward the names of Ordnance Artificers who are recommended and who hold the qualifications required by K.R. and A.I., Appendix XVIII, and Navy Order 528 of 1943, for advancement to Chief Ordnance Artificer, to the Commodore Superintendent of Training, Flinders Naval Depot.

(614/201/12.)

452.

RETENTION OF ACTING HIGHER RANK.

The provisions of A.F.O. 3898 of 1943 have been adopted in the Royal Australian Navy as from 30th October, 1943.

(568/201/931.)

453.

INCOME TAX.

The following information in regard to payment of Income Tax by members of the Royal Australian Navy is promulgated for guidance in preparing personal returns:—

Liability to Render Returns.

All members of the Royal Australian Navy who have not had the requisite seagoing service or service overseas, as indicated hereunder, entitling them to exemption from tax, and are in receipt of income in excess of £250 per annum, are liable to render a return of income received in respect of their service during the period of twelve months ended 30th June in each year to the Deputy Commissioner of Taxation in the State in which enlistment took place.

2. Exemption.

The following sets out the position regarding exemption from payment of Income Tax:—

- (a) The pay and allowances earned as a member of the Naval Forces *outside Australia* are exempt from Income Tax. Members appointed for service out of Australia can therefore claim exemption from the date of embarkation from Australia. Service in a sea-going ship is deemed to be service outside Australia, and exemption applies from the date of joining a sea-going ship.

For the purpose of exemption, Australia means the six States, and does not include any adjacent territory under the control of the Commonwealth, e.g., Papua.

- (b) The pay and allowances earned as a member of the Naval Forces *in Australia* are exempt from taxation provided the member embarks or commences to serve in a sea-going ship during the twelve months following the close of the year of income (30th June each year) and serves outside Australia or in a sea-going ship for not less than *ninety days' continuous service* or *one hundred and eighty days in the aggregate*, during twelve months from the date of his embarkation or commencement of service in a sea-going ship.

A sea-going ship does not include a depot ship or a ship principally employed on or in connection with port or harbour defence.

Sea Service will be defined for these purposes as "Service while borne on the books of"—

- (a) A sea-going ship of war which goes to sea.
(b) A parent ship for service in commissioned sea-going tenders.

(c) A commissioned ship for such other sea-going services as the Naval Board may declare to qualify for this purpose. In this category will be included—

(i) Service while embarked for duty in merchant ships (e.g., D.E.M.S. personnel, Commodores of Convoy and their staffs, &c.).

(ii) Passage in a merchant ship through the areas specified in Navy Order 466 of 1943.

In any case of difficulty, the Naval Board shall determine which vessels or classes of vessels shall be regarded as ships of war, and what nature of service afloat shall be considered as sea service or harbour service.

A member who is exempted under these provisions is on his return to Australia exempted for a further period of three months after his resumption of duty in Australia.

If a member is returned to Australia or discharged from his ship before having served the requisite ninety days out of Australia or in a sea-going ship and his return or discharge to shore is due to illness or injury, he can claim exemption as though he had served the ninety days.

The exemption of pay and allowances earned in Australia applies also to the case of members who, while serving outside Australia or in a sea-going ship die before they have completed the requisite qualifying period.

The above-mentioned amendments apply in respect of pay and allowances earned during the year ended 30th June, 1942, and subsequent years.

(d) Marriage and/or Dependant Allowances are not taxable, and the amounts credited to all personnel in respect thereof should be excluded from the Return of Income. The exemption in respect of these allowances is retrospective to 3rd September, 1939.

3. Particulars of Pay and Allowances to be Included.

Statements are rendered to the Taxation Department by Navy Office showing the actual amount credited in the Ships' Ledgers to all members liable for taxation in respect of each year ended 30th June.

The following items of pay and allowances must be included as income:—

Active Pay.

Badge Pay.

Non-substantive Allowances.

Specialist Allowances.

Lodging, Provision, Leave, Kit Upkeep Allowances, &c.

Where a member is victualled, the value of such subsistence is to be included at 2s. 5d. per diem.

4. Deductions Allowable.

(a) Officers.

In cases where Lodging Allowance is credited in lieu of Marriage Allowance, the Marriage Allowance normally payable should be excluded from the amount of Lodging Allowance actually paid, and only the balance of Lodging Allowance paid should be included for Income Tax purposes. This exemption is applicable as from 3rd September, 1939.

Officers may claim a deduction in respect of the cost of upkeep of uniform. The amount of such claim is limited to eighteen pounds (£18) annually.

(b) Ratings.

Kit Upkeep Allowance credited to a rating may be claimed as a deduction to the extent of the amount actually expended on uniform. The amount claimed, however, must not exceed the amount of Kit Upkeep Allowance credited.

(c) Officers and Ratings.

Rebate of tax is allowed in respect of a member's wife and/or children under 16 years of age who are resident in Australia, and any other dependants resident in Australia of whom the Deputy Commissioner of Taxation may approve. Full particulars of all dependants for whom rebate is claimed should be included in Income Tax return.

Claim for a rebate of tax may also be made in respect of—

(i) Medical expenses incurred. (In this connection receipts should be attached.)

(ii) Contributions to a Superannuation or Provident Fund.

(iii) Insurance premiums, &c.

5. Method of Payment of Taxes.

Owing to liability for sea service, no instalment deductions are made from the pay of members of the Royal Australian Navy (Sea-going Forces), and members must, therefore, make their own arrangements for payment of tax.

6. Adjustments in Respect of Former Years.

Applications for adjustment of tax, where eligible, should be forwarded direct to the Deputy Commissioner of Taxation in the State in which the return was lodged.

7. General Information

It should be clearly understood by all concerned that, where a member is exempt from Income Tax owing to his service in a Seagoing ship or service abroad—

- (a) the exemption only applies to his ordinary pay and allowances, and
- (b) any income received additional to his service pay and allowances is subject to taxation in the ordinary manner.

E.g., as regards (b), commission received by an Accountant Officer as Commonwealth Savings Bank Agent does not come within the exemption allowed to members of the Forces in respect of pay and allowances. Similarly, profits made by personnel who have been allowed to sell copies of photographs in accordance with provisions of Navy Order 23 of 1944 should be included in Return of Income furnished to the Taxation Department.

8. Where the income of the member exceeds £250, a sliding scale has been devised as a "smoothing off" process as follows:—

<i>Amount of Income.</i>	<i>Special Deductions.</i>
Over £250 and up to £258 ..	£146.
Over £258 and up to £300 ..	£146—less £1 for every £1 by which the income exceeds £258.
Over £300 and up to £350 ..	£104—less £1 for every £2 by which the income exceeds £300.
Over £350	£79—less £1 for every £3 by which the income exceeds £350.

The special deduction vanishes, therefore, at an income of £587.

9. The *Income Tax Assessment Act* of 1944 contains a further provision for the remission of unpaid tax attributable to the inclusion of Service pay and allowances in assessments in the case of members of the Forces who lost their lives. The provision applies to any person who has been a member of the Forces if the circumstances of his service and the circumstances of his death are such that the Commonwealth would be liable to pay pensions under the *Australian Soldiers' Repatriation Act* 1920-1943 to his dependants.

Where the taxpayer's income consists solely of Service pay and allowances, the amount to be remitted is the amount of tax outstanding, less any tax instalment deductions which have been made from his Service pay and allowances, and have not been credited in payment of tax assessed.

Where the income of the deceased includes income other than Service pay and allowances, the amount to be remitted is the amount remaining after deducting from the lesser of the following amounts the amount of tax instalment deductions made from the Service pay and allowances of the deceased which have not been credited in payment of tax assessed:—

- (a) The amount of tax outstanding ; or

- (b) The amount by which the income tax payable by the deceased had been increased by the inclusion of Service pay and allowances in his assessment.

This applies to amounts of income tax outstanding at 3rd April, 1944, or becoming payable thereafter.

10. Under the recent amendment of the Act, representatives of such institutions as the Red Cross Society, Australian Comforts Fund, Salvation Army and Y.M.C.A., members of the Broadcasting Units established by the Australian Broadcasting Commission, war correspondents and photographers employed by the Department of Information and camouflage officers of the Department of Home Security are exempt where such persons are accredited by an Authority of the Defence Force and are attached to and accompany a body, a contingent or detachment of that Force serving outside Australia.

The deduction allowed is limited to the amount of the remuneration derived by them while associated with the Forces outside Australia, and applies to income derived during the year ended 30th June, 1942, and subsequent years.

11. Members liable to furnish Income Tax returns are reminded that their returns must be lodged with the Deputy Commissioner of Taxation in the State in which enlisted on or before the 31st July, each year.

(621/201/5979.)

(This Order is to be reprinted for posting on the Notice Boards.)

454.

VENTILATION OF H.M.A. VESSELS.

Reports indicate that the efficiency of the ventilation systems of various vessels has dropped considerably, owing to the lack of proper care and attention.

2. It is important that gratings of wire mesh covering openings in ventilation trunks should not be painted, as they are liable quickly to be clogged.

3. Every precaution is to be taken to keep the inside of trunks clean, and, where a lot of dust has accumulated, this is to be blown out by compressed air at the first opportunity.

(603/247/1792.)

455.

H.D.M.L'S EX U.S.A.—FITTING OF TWIN VICKERS .303-in. MOUNTINGS—ALTERATIONS AND ADDITIONS.

Two twin mountings for guns machine Vickers .303-in. G.O. are to be fitted in all H.D.M.L's in lieu of the two single .300-in. Savage Lewis guns at present fitted.

2. Administrative authorities are to raise an alteration and addition item accordingly.

3. The work is to be carried out by Base Staffs. Guns and mountings are to be demanded from Sydney.

(411/201/212.)

456.

STORES TRANSFERRED FROM THE U.S. NAVY TO THE R.A.N.

In connection with the transfer of Naval and Naval Armament Stores from the U.S. Navy to the R.A.N., all H.M.A. Ships to which such stores are supplied are to insert the following certificate on the relevant transfer vouchers:—

“ I certify that the items referred to herein have been received and taken on charge in the Naval (or Naval Armament) Store Account Ledger, page.....

.....
 (Accounting Officer) ”

2. A copy of the certified vouchers should be forwarded to Navy Office with the quarterly return of Forms A.S.549 in the case of Naval Stores, and by covering memorandum in the case of Naval Armament Stores.

(612/212/3024.)

457.

TABLE CLOTHS AND MATS.

With reference to Navy Order 5 of 1944 it is notified that the allowances of table linen promulgated in paragraph 1 thereof are cancelled, and the following allowances are to operate forthwith:—

Flag and Commanding Officers' Messes.

2 No. cloths per table, plus up to 24 No. cotton mats and 12 No. linoleum mats as required.

Other Officers' Messes.

1 No. cloth per table, plus 2 No. cotton mats and 1 No. linoleum mat for each officer. In addition, 25 per cent. of the total number of cotton mats and 10 per cent. of the total number of linoleum mats as spares, subject to a minimum allowance for spares of 4 No. cotton mats and 2 No. linoleum mats per table.

2. All table cloths held in excess of the revised allowances are to be withdrawn from use and, except for one cloth per table which may be retained as a reserve, are to be returned to the nearest H.M.A. Victualling Yard or Depot as early as practicable.

3. Table mats may be obtained, on demand, from the Royal Edward Victualling Yard, Sydney, or from H.M.A. Naval Victualling Depots at Fremantle, Port Melbourne and Brisbane.

4. These revised allowances are necessary to utilize to the best advantage existing stocks of table linen which are seriously depleted, and the replenishment of which is most unlikely during the period of the war.

(530/201/502.)

458.

SUPPLY OF OFFICERS' UNIFORMS—INCLUSION OF ADDITIONAL OUTFITTER FOR R.A.N. NURSES AND W.R.A.N.S. OFFICERS.

Arrangements have been made with Messrs R. Simons and Sons, 313 Flinders-lane, Melbourne, for the supply, under the terms of the Agreement, of made-to-measure uniforms (Jackets, Skirts, Greatcoats and Nurses Capes), for R.A.N. Nurses and W.R.A.N.S. Officers.

2. Navy Order 407 of 1944 is to be amplified accordingly.
 (434/215/1102.)

459.

REFUND OF FLOUR TAX.

The rendition of certificates showing quantities of flour consumed outside territorial waters and in the Northern Territory, as required by Navy Order 101 of 1939, is to be discontinued.

(668/207/206.)

460.

SOUTHERN CROSS CLUB, NEW YORK CITY, U.S.A.

The Southern Cross Club, at 16 East 54th Street, New York City, U.S.A., has been formed to provide comfort and entertainment for members of the Armed Forces of Australia and New Zealand.

2. Any members of the Naval Forces passing through New York are invited to use the facilities offered by the Club.

(This Order will be reprinted for posting on Notice Boards.)

(552/201/1206.)

461.

RATINGS' UNIFORM—DEVIATION FROM STANDARD PATTERNS.

It has again come to the notice of the Naval Board that ratings buying Service clothing on shore are sometimes supplied with articles of uniform which deviate considerably from standard sealed patterns. Examples of this are jumpers cut in “U” shape and much too low, collars narrow and overlong, and trousers tailored to produce an exaggerated bell-bottom effect.

2. It is permitted that made-to-measure garments may be completed, if desired, with the following extras which in no way affect the cut or outward appearance of uniforms, and for which provision has been made in current contracts, viz:—

- (a) leather bindings or tapings on cuffs of trousers;
- (b) straight tops on fly trousers;
- (c) extra inside pockets on S.B. jackets;
- (d) hip pockets on fly trousers;
- (e) fob pockets on fly trousers;
- (f) extension bands and pleats on fly trousers;
- (g) zipp fasteners on fall trousers.

3. Under Regulation 31A of the National Security (General) Regulations only authorized individuals or firms may, for the period of the war, supply Naval uniforms, and traders and outfitters concerned have been advised that the variations listed in paragraph 2 are the sole authorized departures from standard Naval patterns. They are also being informed that, in the event of the supply by them in future of items of uniform not conforming strictly with Departmental requirements, action will be immediately taken by the Naval Board to withdraw their existing permit authorizing the supply of Naval uniform. With that object in view, Commanding Officers should report to the Naval Board any breaches of such requirement coming to their notice.

4. It is pointed out that ratings are liable to disciplinary action for breach or non-observance of current dress regulations.

(434/216/83.)

(This Order will be reprinted for posting on Notice Boards.)

462.

SIGNATURE OF NAVAL BOARD DOCUMENTS.

With reference to C.O.R., Article 2, clause 5, the Naval Board have authorized Mr. J. J. Mullany, of Navy Office Secretariat, to sign official documents for and on behalf of the Secretary to the Naval Board.

(712/201/987.)

463.

CORRIGENDUM.

With reference to Navy Order 412 of 1944—"Air Sea Rescue Vessels—Allocation of Names"—amend the name of Air Sea Rescue Vessel No. C.26686 to read "Air Trail".

(603/247/1775.)

RESTRICTED.

(FOR OFFICIAL USE ONLY.)

Commonwealth Navy Orders.

Navy Office, Melbourne,
5th September, 1944.

The following Orders, having been approved, are hereby promulgated for information and guidance and necessary action.

By direction of the Naval Board,

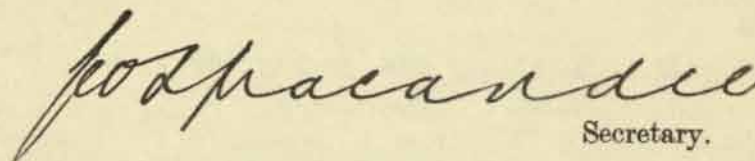
Secretary.

*The Commodore Commanding H.M.A. Squadron,
and Commanding Officers of H.M.A. Ships,
Officers in Charge of H.M.A. Naval
Establishments, and others concerned.*

TABLE OF CONTENTS.

No.	Subject.
464.	Training and Staff Requirements Division, Navy Office.
465.	20 mm. Oerlikon Gun—Locking of Barrel.
466.	O.Q.F. 40 mm. Bofors—Lockings of Screws, Securing Bracket Supporting Buffer—Fitting of Shakeproof Washers.
467.	Ship's Ledger and Pay Accounts.
468.	Lifesaving Rafts—Release of.
469.	Wartime Allowances of Bedding—R.A.N. Shore Establishments.
470.	Books and Forms.
471.	Service Allotments for Continuous Subscriptions to War Loans.
472.	"Home Made" Range and Deflection Calculators.

464.

TRAINING AND STAFF REQUIREMENTS DIVISION, NAVY OFFICE.

A Training and Staff Requirements Division of the Naval Staff has been established at Navy Office.

2. This Division will carry out functions similar to the combined functions of "A/S Warfare," "Gunnery," "Naval Training" and "Tactical, Torpedo and Staff Duties" Division of the Naval Staff, Admiralty.

3. The Director of Training and Staff Requirements is authorized to visit all training establishments and to correspond direct with officers-in-charge on training matters.

(600/201/2435.)

465.

20 mm. OERLIKON GUN—LOCKING OF BARREL.

Pending the receipt of B.R. 274/43, the following instructions are to be added to B.R. 274/41, page 15, sub-paragraph V of paragraph 47.

"After engaging the barrel locking lever, and to ensure that the barrel is properly fitted and locked, grasp the barrel and try to turn it either way. If it can be turned the barrel is not properly home or locked."

(490/212/987.)

466.

O.Q.F. 40 mm. BOFORS—LOCKINGS OF SCREWS, SECURING BRACKET SUPPORTING BUFFER—FITTING OF SHAKEPROOF WASHERS.

The modification referred to in A.F.O. 41/44 is also to be applied to O.Q.F. 40 mm. Mark I and I* in the R.A.N.

2. Ships are to demand the shakeproof washers required from the nearest Naval Armament Depot or Base. Bases are to demand requirement from the Superintending Armament Supply Officer, Sydney.

(490/212/1119.)

467.

SHIP'S LEDGER AND PAY ACCOUNTS.

Attention is directed to the necessity for the closest observance by all concerned of the procedure laid down in Section 4 of Part II, i.e., Articles 101-131, of the Naval Account Regulations and Instructions in regard to Ship's Ledger and Pay Accounts.

2. The following aspects, in connection with the keeping of Ship's Ledgers, are particularly emphasized:—

- (a) the Ledger is to be kept constantly complete by the entry of every transaction or particular at the time of its occurrence;
- (b) the ledger shall be kept in duplicate independently and concurrently, so that one may serve as a check upon the other;
- (c) the ship's ledger should be in agreement in every particular with that which is sent into office;
- (d) an Abstract Form A.S. 41B, duly balanced, is to be rendered for the complete ledger (it should be agreed first with both copies of ledger);
- (e) where the ship's complement admits of it, one of the ledgers is to be kept by a Paymaster Sub-Lieutenant or Paymaster Lieutenant.

3. Compliance with the above requirements should ensure that ledgers as sent to office are correct in all respects. It can only be assumed from inaccuracies which have been disclosed on examination of some ledgers in Navy Office that these Orders are not being fully complied with in all cases.

4. The Naval Board direct attention to the responsibility which rests on the Accountant Officer to ensure that the standing orders in this matter are carefully observed and the ledgers are correct in all respects, when rendered.

(556/201/2017.)

468.

LIFESAVING RAFTS—RELEASE OF.

In certain H.M.A. Ships, Carley Floats are secured by strops with senhouse slips. It has been found that even in the course of a fortnight after contact with salt water the galvanized safety pin in a new senhouse slip may be seized in.

2. Commanding Officers are to ensure by weekly inspection that all lifesaving equipment is ready for immediate use and that senhouse slip safety pins are chained on and free in the cotter way, and also that gripe hammers are secured alongside every slip ready for immediate use.

3. Attention is called to A.F.O. 1220/42—Lifesaving in H.M. Naval Service.

(612/231/354.)

469.

**WARTIME ALLOWANCES OF BEDDING—R.A.N. SHORE
ESTABLISHMENTS.**

The wartime allowances of bedding for male personnel occupying Service accommodation in R.A.N. Shore Establishments are to be as prescribed in A.F.O. 651/44. It will be seen that sheets are not now authorized except in the case of Commanders or Captains in Command and in Sick Bays.

2. Bedding at present on issue in excess of the revised allowances is to be withdrawn, but where 3-ft. bedsteads have been supplied to ratings' sleeping quarters, fibre or other mattresses now in use may be retained. In all other cases the hammock hair bed of his kit is to be utilized by each rating.

3. The general arrangements for supply, accounting, &c., of bedding are set out in Navy Order 489 of 1943.

4. Bedding for W.R.A.N.S. is provided for in Navy Orders 169, 218 and 386 of 1944.

5. Navy Order 315 of 1943 is cancelled.

(612/235/889.)

470.

BOOKS AND FORMS.

A small size Form A.S. 134b has been adopted for intermittent use where only a few items are required. A proportionate supply of these Forms will be issued by the Superintending Naval Store Officer, Sydney, when demands for supplies of the standard size A.S. 134b are received.

A.S. 134b (small) Demands to Replenish—Supplementary.

(A.F.O. 1268/43.)
(480/202/4514.)

2. The reprint of the under-mentioned forms has been suspended for the duration of hostilities:—

A.S. 219—Absentees on Sailing. (480/202/4571.)
S.1169—Report of A/S Exercises Attack Form.

(480/202/4626.)

471.

**SERVICE ALLOTMENTS FOR CONTINUOUS SUBSCRIPTIONS TO
WAR LOANS.**

Arrangements have been completed whereby Service personnel may make allotments of pay at any time as continuous subscriptions for the purchase of bonds in Commonwealth War Loans.

2. It is intended that such allotments shall be declared at fortnightly rates of not less than 5s., in favour of the Commonwealth Bank of

Australia, in the Capital City of the State in which purchase of the bonds is desired. Forms A.S. 63 should clearly indicate that the allotment is for continuous subscription to War Loans. Simultaneously with the declaration of the allotment, a form of application (pro forma appended) must be completed by the applicant and forwarded, attached to Form A.S. 63, to Director of Navy Accounts, Navy Office.

3. These allotments will be paid by the bank to a special account in the member's name, on which interest will be allowed at the rate borne by the bond selected for purchase by the member. As the sum of £10 accumulates in the account, the bank will purchase a £10 Commonwealth Treasury Bond and place it in safe custody for the applicant.

4. These allotments will continue to be paid until stopped by the allottor or where, for service reasons, stoppage is necessary. The balance of the amount subscribed which has not been invested may be credited to the member's bank account or paid by him, whichever he desires.

5. The instructions already issued in connection with the declaration of allotments for purchase of bonds in specific loans are not affected by the foregoing.

6. Supplies of application forms will be issued in due course.

ALLOTMENT.

No..... Rank.....

Name in Full.....
(In block letters)

Address
(Ship, &c.)

Civilian Address

To Commonwealth Bank of Australia.

I have authorized the Department of the Navy to allot the sum of.....shillings per fortnight from my pay and to forward such allotments to you for purchase of ^{SHORT TERM} ~~LONG TERM~~ Commonwealth Treasury Bonds on my behalf from time to time as sufficient funds accrue.

Please hold the bonds for safe custody and credit interest to my account with

(Bank)

.....
(Branch) (No. of Savings Bank A/c.)

Date.....
(Signature)

Specimen Signature of Applicant.

No.....

(556/207/5257.)

(This Order will be reprinted for posting on Notice Boards.)

472.

"HOME MADE" RANGE AND DEFLECTION CALCULATORS.

With reference to Confidential Admiralty Fleet Order 2266 of 1943, Home Made Range and Deflection calculators are now available for distribution.

2. Ships and Establishments, as indicated, are to demand these instruments from the Senior Naval Store Officer, Sydney:—

Flinders Naval Depot	5
Gunnery Instructional Centre, Sydney	2
Gunnery Instructional Centre, Fremantle	2
Gunnery Instructional Centre, Port Melbourne	2
N.O.I.C., Cairns	1
A.M.S. Vessels	1 each.
Frigates 1 to 8	1 each.

(490/214/396.)

RESTRICTED.(FOR OFFICIAL USE ONLY.)

Commonwealth Navy Orders.

Navy Office, Melbourne,
12th September, 1944.

The following Orders, having been approved, are hereby promulgated for information and guidance, and necessary action.

By direction of the Naval Board,

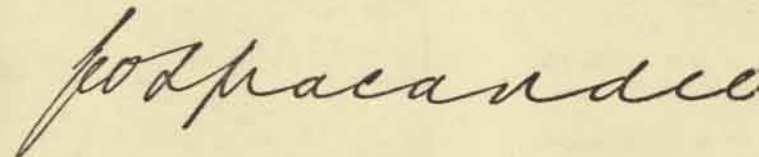

Secretary.

*The Commodore Commanding H.M.A. Squadron,
and Commanding Officers of H.M.A. Ships,
Officers in Charge of H.M.A. Naval
Establishments, and others concerned.*

TABLE OF CONTENTS.

No.	Subject.
473.	Educational Test I—June, 1944.
474.	Temporary Commissions—Selection of Ratings from the Lower Deck.
475.	Service Chevrons.
476.	Next-of-kin Particulars—Insertion in September Quarter Ledger.
477.	Butts for Guns Machine Vickers .303-in. on Single A.A. Mountings.
478.	Tails Propelling Rocket U. 2-in. H.E. Lot No. 73.—Withdrawal.
479.	A.M.S. Vessels—Gardner Diesel Engines for LL Sweeps—Circulating Water Header Tanks.
480.	Privately-Owned Musical Instruments—Loss or Damage as the Result of a Service Casualty.
481.	Books and Forms.
482.	Statements by Service Medical Officers Regarding Benefits After Discharge.
483.	National Security (General) Regulations—Order Made Thereunder—Immobilization of Vessels Order (No. 3).
484.	Revised Canteen Arrangements in R.A.N. and Establishment of a R.A.N. Central Canteen Fund.

473.

EDUCATIONAL TEST I—JUNE 1944.

The following ratings passed Educational Test I, held on 27th June, 1944:—

Name.	Rating.	Official Number.
<i>H.M.A.S. Arunta.</i>		
Strachan, William	Able Seaman (Radar)	S/7677
<i>H.M.A.S. Australia.</i>		
Harvey, McDonald C.	Steward	24462
<i>H.M.A.S. Barcoo.</i>		
Coleman, Robert F.	Ordinary Seaman	S/8160
Keating, Morton K.	Able Seaman	23876
<i>H.M.A.S. Benalla.</i>		
Roberts, Llewellyn	Steward	PA/2809
<i>H.M.A.S. Cerberus.</i>		
Bain, Graham H.	Stoker, 2nd Class	PA/4523
Barnett, Keith D.	Stoker, 2nd Class	S/9119
Bull, Robert L.	Acting Stoker	W/2631
Coghlan, Ronald A. G.	Acting Stoker	F/4582
Currie, Frederick C.	Acting Stoker	S/8116
Foster, Raymond L.	Stoker, 2nd Class	B/4456
Gell, Garnett R.	Acting Stoker	F/4900
Gibson, Ian R.	Acting Stoker	B/4493
Hall, Keith L.	Stoker	W/2582
Hampshire, Calvin L.	Stoker, 2nd Class	S/7691
Heapy, Edward G.	Acting Stoker	S/7693
Levick, Colin J.	Stoker	S/6234
McDowell, Cyril A.	Acting Stoker	S/7922
Redman, Ronald F.	Acting Stoker	PA/3242
Renwick, Ian E. K.	Stoker, 2nd Class	W/2949
Rundle, Graham F.	Acting Stoker	PA/2998
Simmons, Aver G.	Acting Stoker	PA/3555
Smith, Arthur J.	Acting Stoker	B/4080
Sutherland, Donald C.	Stoker	PM/3039
Thorn, Clarence R.	Acting Stoker	W/2700
Waye, George W.	Acting Stoker	PA/2945
<i>H.M.A.S. Ladava.</i>		
Pearce, Victor C.	Stoker, 2nd Class	W/2867
Woolston, Arthur R.	S.B.A. (D)	S/6448
<i>H.M.A.S. Melville.</i> (Including Boom Defence Depot.)		
Abbott, William H.	Leading Signalman	PM/2431
Campbell, Alexander	Stoker	26715
Gillett, Geoffrey L.	Coder	26523
Knighton, Charles C.	Able Seaman	S/6259
Menzies, Leslie G.	Able Seaman	B/4158
O'Connor, Kevin J.	Supply Assistant	B/4377
Plumb, Gordon J.	Stoker, 2nd Class	26719
Pryor, Louis B.	Ordinary Coder	26533
Taylor, Edward J.	Stoker	S/7704
Tregaskis, John B.	Wireman	26883

EDUCATIONAL TEST I—continued.

Name.	Rating.	Official Number.
The following qualified educationally for Acting Leading Stoker:—		
<i>H.M.A.S. Cerberus.</i>		
Bench, Rodney	Acting Stoker	W/2717
Carty, Michael	Acting Stoker	PA/3157
Downs, Brian A.	Acting Stoker	PA/3321
Dyson, Walter	Acting Stoker	B/3633
Keane, Garret	Stoker, 2nd Class	W/2996
Von-Paleske, Kenneth G.	Acting Stoker	F/4844
<i>H.M.A.S. Moreton.</i>		
Pemble, Edward F.	Stoker	S/8394

(465/205/664.)

(This Order will be reprinted for posting on Notice Boards.)

474.

TEMPORARY COMMISSIONS—SELECTION OF RATINGS FROM THE LOWER DECK.

The following amendments are to be made to Navy Order 103 of 1943:—

- For "9 weeks' duration" in paragraph 8 substitute "16 weeks' duration";
- Paragraph 11 is to be omitted and the following paragraph substituted in its stead:—

"11. Ordinary Seamen and Able Seamen not selected for commissions will, if recommended by the Naval Officer-in-Charge, Flinders Naval Depot, be regarded as fully qualified by examination for Leading Seaman. Similarly, Leading Seamen will, if recommended, be regarded as fully qualified by examination for Petty Officer."

(568/202/1009.)

475.

SERVICE CHEVRONS.

Chevrons for war service may be issued to the Women's Royal Australian Naval Service and the Royal Australian Naval Nursing Service under the conditions laid down in Navy Order 219 of 1944.

(416/201/1033.)

(This Order will be reprinted for posting on Notice Boards.)

476.

**NEXT-OF-KIN PARTICULARS—INSERTION IN SEPTEMBER
QUARTER LEDGER.**

The attention of all Commanding Officers is drawn to the necessity for strict compliance with the provisions of Navy Order 297 of 1942 regarding the insertion in September quarter ledger of the name and address of the nearest relative or friend of all personnel, including Canteen Staff.

2. It is again emphasized that the information is essential for casualty purposes in the case of officers as well as men, and that Bank or Post Office addresses are not acceptable for this purpose.

(675/201/128.)

477.

**BUTTS FOR GUNS MACHINE VICKERS .303-IN. ON SINGLE
A.A. MOUNTINGS.**

The fitting of butts to Guns Machine Vickers .303-in. as described in Navy Order 39 of 1944 is not being proceeded with.

2. Navy Order 39 of 1944 is cancelled.

(490/212/802.)

478.

**TAILS PROPELLING ROCKET U. 2-IN. H.E. LOT NO. 73—
WITHDRAWAL.**

Appended, for information and necessary action, is copy of Admiralty Fleet Order 2860/44 which has not yet been promulgated on the Australia Station:—

“It has been decided to withdraw tails, propelling, rocket U. 2-in., of Lot No. 73 cordite, Lot R.N.P. 474. All tails of this lot should be dumped at the first opportunity, and replacements demanded from Naval Armament Depots as required.”

(471/208/1173.)

479.

**A.M.S. VESSELS GARDNER DIESEL ENGINES FOR LL SWEEPS—
CIRCULATING WATER HEADER TANKS.**

The salt water header tank, fitted in the circulating water system of the above engines, is to be modified in accordance with the appended Navy Office drawing No. 910199.

2. This modification will prevent the header tank overflowing during adverse weather conditions.

3. The Commanding Officers of A.M.S. vessels concerned are to include an item in the next Supplementary Defect List, for base staff assistance, as required, to undertake this work.

(524/202/1753.)

NAVY OFFICE DRAWING	
NO. 910199	DATE 20.7.44
BY [Signature]	CHECKED BY [Signature]
DESIGNED BY [Signature]	SCALE: 3" & 1" = 1'-0"
APPROVED BY [Signature]	EXAMINED BY [Signature]
DRAWN BY [Signature]	

**A.M.S. VESSELS.
MODIFICATIONS TO FITTINGS ON SALT WATER
HEADER TANK.**

**FOR 42 K.W. GENERATORS.
SCALE: 3" & 1" = 1'-0"**

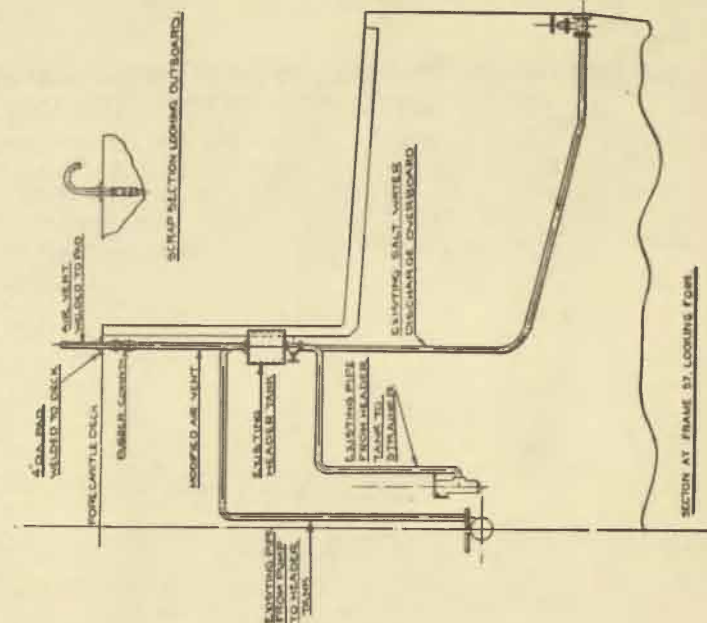
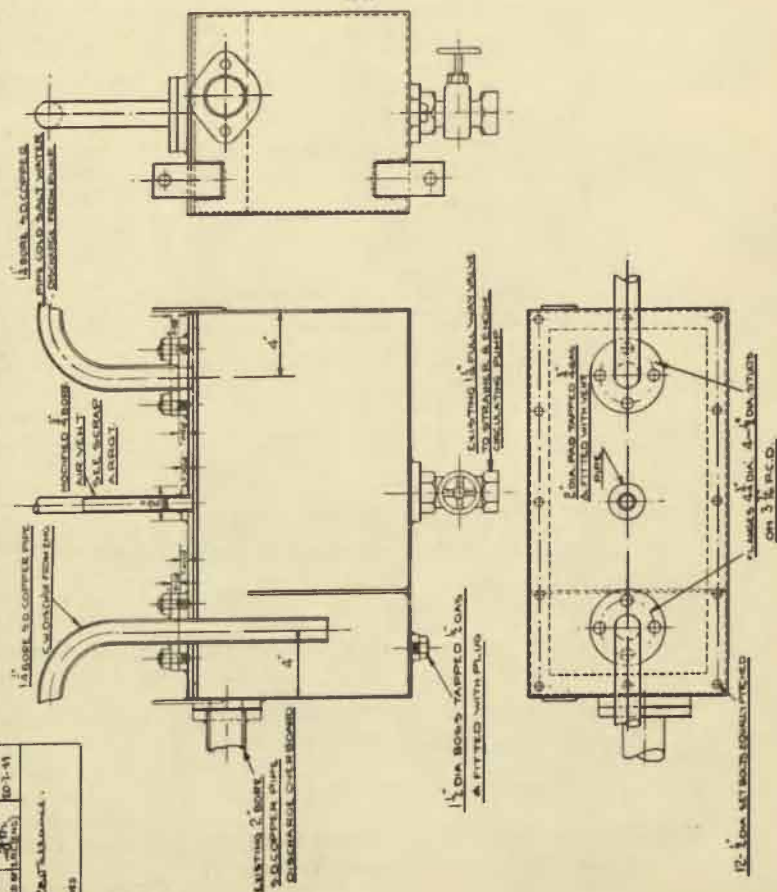

480.

PRIVATELY-OWNED MUSICAL INSTRUMENTS—LOSS OR DAMAGE AS THE RESULT OF A SERVICE CASUALTY.

It is notified for general information that private musical instruments of any description taken on board H.M.A. Ships or Establishments are held on board entirely at the owner's risk, and in no circumstances will liability be accepted by the Department should loss or damage occur as the result of a Service casualty.

(438/204/487.)

(This Order will be reprinted for posting on Notice Boards.)

481.

BOOKS AND FORMS.

First supplies of the under-mentioned publications have been distributed. Further supplies of B.R.783, Amendments Nos. 52, 53, 54 to A.P.1976 and Journal of the Royal Navy Medical Services, January, 1944, are being obtained to complete distribution:—

B.R.234/43.—Drill with Respirator Anti Gas.

(A.F.O. 627/44.)

(571/202/1982.)

Errata Nos. 4 and 5 to B.R.363 and Errata Nos. 1 and 2 to Form D.126.—Lists of Errata to the Establishment of Naval Stores and List of Particulars for Submarines (Oberon and Later Classes).

(A.F.Os. 6090/42 and 5916/43.)

(571/202/1873.)

B.R.637.—Mersigs, Volume I, French Edition.

(571/202/1800.)

B.R.650/43.—Notes on the 0.303-in. Browning Gun, Type A, Mark II*.

(A.F.O. 1004/43.)

(571/202/1752.)

B.R.695.—List of International Telegraph Offices—Annexe Nos. 40 and 43, Parts I and II.

(A.F.Os. 3760/43 and 889/44.)

(571/202/1814.)

B.R.783 (1) (2) (3) (4).—The Services Radio Valve Manual.

(A.F.Os. 648 and 759/44.)

(571/202/1919.)

B.R.868/43.—Preliminary Pamphlet for Q.F. 6-pdr., Mark IIA Gun on 6-pdr., Mark VII Mounting.

(A.F.O. 629/44.)

(571/202/1937.)

B.R.912 (late C.B.1925).—Guard Book and Index for Pamphlets of the Director Handbook, Volume II.

(A.F.O. 5796/43.)

(571/202/1909.)

B.R.918/43 (supersedes B.R.918 (40), formerly C.B.4087).—Handbook and Drill for the 0.5-in. Vickers Gun on 0.5-in. Twin, Mark V Mounting (Powered).

(A.F.O. 496/44.)

(571/202/1902.)

B.R.970/43.—Handbook for 3-in. 20-cwt. Mark I Gun on C.P., Mark V Mounting.

(A.F.O. 101/44.)

(571/202/1942.)

B.R.984/43 (supersedes C.B.(R)4180B/42.—Radar Operating Procedure—Part II, Drill for Gunnery Radar Sets.

(A.F.O. 1428/44.)

(571/202/1984.)

B.R.998/44.—Drill for High Angle Control System Mark III.

(A.F.O. 1279/44.)

(571/202/1956.)

B.R.1088 (late S.P.02509).—Indicating Groups for S.S. Frames.

(571/202/1988.)

A.P.1480A.—Amendment List Nos. 106-108—Silhouettes of British Aircraft.

(A.F.O. 1428/44.)

(571/201/4155.)

A.P.1976.—Amendment List Nos. 52, 53, and 54.—Performance Tables of Foreign Service Aircraft.

(A.F.Os. 889 and 1428/44.)

(571/201/3731.)

C.C.B.P.7.—Combined Communications Instructions.

(571/203/2519.)

Errata No. 3.—Establishment of Naval Stores for 72-ft. Motor Launches.

(612/226/1232.)

Journal of the Royal Navy Medical Services, January, 1944.

(571/201/3668.)

Army Training Memorandum (War) (Australia) No. 34.

(546/201/443.)

482.

STATEMENTS BY SERVICE MEDICAL OFFICERS REGARDING BENEFITS AFTER DISCHARGE.

All medical officers conducting Boards of Survey where Repatriation aspects are involved, are to refrain from making any remarks likely to lead to subsequent misunderstanding between members of the Forces and the Departments concerned in their welfare following discharge.

2. This applies particularly to such matters as liability of the Repatriation Department for the performance of surgical operations subsequent to discharge.

(527/203/829.)

483.

NATIONAL SECURITY (GENERAL) REGULATIONS—ORDER
MADE THEREUNDER.

The following is promulgated for information:—

(*Commonwealth Gazette*, No. 170, dated 25th August, 1944.)

COMMONWEALTH OF AUSTRALIA.

NATIONAL SECURITY (GENERAL) REGULATIONS.

Immobilization of Vessels Order (No. 3).

In pursuance of the powers conferred on the Minister of State for the Navy by Regulation 45D of the National Security (General) Regulations and delegated by him to me by Instrument of Delegation, dated the twenty-first day of September, 1943, I, Guy Charles Cecil Royle, Chief of the Naval Staff, hereby order as follows:—

1.—(1) This Order may be cited as the Immobilization of Vessels Order (No. 3).

(2) The amendment of the Immobilization of Vessels Order made on the thirteenth day of March, 1943, and published in the *Gazette* on the twenty-third day of March, 1943, may be cited as the Immobilization of Vessels Order (No. 2).

2. Sub-paragraph (1) of paragraph 2 of the Immobilization of Vessels Order is amended by omitting the definition of “immobilize” and inserting in its stead the following definition:—

“‘immobilize’, in relation to a vessel, means to render the vessel incapable of being used;”.

3. Paragraphs 5, 6, and 7 of the Immobilization of Vessels Order are revoked.

Dated this 18th day of August, 1944.

G. C. C. ROYLE,
Chief of the Naval Staff.

484.

REVISED CANTEEN ARRANGEMENTS IN R.A.N. AND
ESTABLISHMENT OF A R.A.N. CENTRAL CANTEEN FUND.

In order to improve and co-ordinate, as far as is practicable, existing canteen arrangements in H.M.A. Ships and Establishments, and to ensure that adequate supplies at uniform prices are at all times available to Naval personnel, wherever serving, the Naval Board recently made representations to the Department of the Army requesting that the wide facilities and resources of the Australian Army Canteens Service be placed at the disposal of the Naval Service to a much greater extent in future than has been the practice hitherto.

2. The Department of the Army readily assented to give all possible assistance in the direction desired, and details of the arrangements made and procedure to be closely observed, as outlined in Naval Board general signal No. 260601, August, 1944, are set out hereunder:—

A.—SERVICE SYSTEM CANTEENS.

- (i) The Australian Army Canteens Service has undertaken to maintain regular supplies of canteen stores to all such Naval canteens (whether ashore or afloat) which are, as a standing principle, to demand their requirements of canteen stores in future from the most convenient Australian Army Canteens Service Issuing Point (a list of Issuing Points concerned is shown in the Appendix to this Order), obtaining supplies from other sources only in case of emergency. When it is desired, however, to include in canteen stocks on board an article (apart from a different brand only) of a nature not normally held in the Australian Army Canteens Service stocks, supplies should be obtained direct from the manufacturer or merchant and the issuing price controlled as has been past practice. In this connection attention is drawn to K.R. & A.I., Article 630 (6).
- (ii) Stores will be supplied to Service System Canteens at the Australian Army Canteens Service Retail Prices operating in the area of supply, less a discount of 5 per cent. At Brisbane, Sydney, Melbourne, Adelaide and Fremantle, bonded stores for sea-going ships will, however, be supplied at cost price plus 2½ per cent. All supplies by the Australian Army Canteens Service will be made on a strictly cash basis.
- (iii) A rebate of 5 per cent. on the amount of the total purchases of all Service System Canteens, excluding purchases of bonded stores at the ports named in (ii), will be paid monthly to Navy Office by the Central Canteens Control Board and be accompanied by a schedule showing the amount due in respect of the total monthly purchases of each ship and establishment. One-third of this rebate will be paid to the credit of the newly-created R.A.N. Central Canteen Fund, the functions of which are set out in section D hereunder, whilst the remaining two-thirds will be paid, through Accountant Officers, to the individual ships and establishments concerned.
- (iv) Supplies obtained from the Australian Army Canteens Service are to be sold to Ships' Companies at the prices shown in the current Australian Army Canteens Service Retail Price List for the area of supply, with the exception of goods obtained at the ports enumerated in (ii) above and which are authorized to be supplied duty or excise free to seagoing ships. In such cases, issuing prices approximating the New Guinea prices for corresponding items are to be used. Copies of current Australian Army Canteens Service price lists may be obtained from the Australian Army Canteens Service representatives at all main ports in Australia and New Guinea.

- (v) C.O.R., Articles 454 and 455, clause 2, also Navy Order 462 of 1942, provide that Naval Board approval is necessary to the establishment of a canteen in any H.M.A. Ship or Establishment, or other place used exclusively by Naval personnel. This approval is necessary whether or not an advance from public funds is desired in accordance with Naval Account Regulations and Instructions, Article 61. Any ship or establishment in which a Service System Canteen is at present operating without specific Naval Board approval, other than A.M.S. Vessels and Frigates in which the establishment of a canteen has been approved by a Naval Officer-in-Charge under authority delegated by the Naval Board, is therefore to report the matter to Navy Office forthwith for covering approval.
- (vi) In accordance with Naval Account Regulations and Instructions, Article 61, ships and establishments in which Service System Canteens are established may receive an advance up to a maximum of £2 per head of complement, exclusive of commissioned officers. Ships and establishments which have previously received no advance, or an advance of less than the maximum authorized by Naval Account Regulations and Instructions, should apply forthwith for the financial assistance or the further financial assistance now desired, the reasons for the latter being clearly stated.
- (vii) Naval Officers-in-Charge and Port Directors are required to co-operate with the local representatives of the Australian Army Canteens Service, who are to be furnished with such information as is necessary in order to ensure the maintenance locally of adequate stocks to meet known and anticipated requirements of Naval canteens on shore or in H.M.A. Ships requiring replenishment at the port.
- (viii) In ships and establishments with a Service System Canteen, the general procedure prescribed in K.R. & A.I., Article 632, is to apply wherever an Accountant Officer is borne. A modified procedure is being prepared for strict observance by Service System Canteens where an Accountant Officer is not borne, details of which will be promulgated in a further Navy Order at an early date.

B.—CANTEENS CONDUCTED BY THE AUSTRALIAN ARMY CANTEENS SERVICE.

- (i) In Naval Establishments where canteens are wholly conducted by the Australian Army Canteens Service, a monthly rebate of 5 per cent. on total retail sales will be paid to Navy Office and will be distributed in the same manner as provided in section A (iii) above, viz., one-third will be paid to the newly-created R.A.N. Central Canteen Fund and the balance to the individual establishment concerned, through the Accountant Officer.
- (ii) Any complaint which may arise in connection with any one of these canteens, both in respect of stocks or service, should be investigated by the Commanding Officer who, if necessary, will represent the matter to the local District Board of the Australian Army Canteens Service, a copy

of any communication being forwarded to the Naval Board for information and further action, if considered desirable, with the Central Canteens Control Board through the Department of the Army.

C.—TENANT CANTEENS.

- (i) The Australian Army Canteens Service will, when so requested, assist canteen tenants in H.M.A. Ships in procuring their requirements of stores. Where these are drawn from the Australian Army Canteens Service Issuing Points, the basis of charge will be as provided in Section A above.
- (ii) In order that seagoing ships with canteen tenants may participate in contributing to the Central Canteen Fund, action is being taken to increase, as from 1st October, existing rentals by 25 per cent. in all cases, the whole of such increase to be paid by the Accountant Officer quarterly to the credit of Trust Fund—Other Trust Moneys—for eventual payment through Navy Office to the Central Fund.

D.—R.A.N. CENTRAL CANTEEN FUND.

- (i) The Naval Board have decided to establish a special fund to be known as the R.A.N. Central Canteen Fund, the functions of which will be—
- to provide amenities of a general nature beyond the capacity of an individual ship or establishment;
 - to contribute the Navy share to certain special funds now used to augment the Government scheme for the education of children of deceased or disabled servicemen; and
 - to promote the welfare of Naval or ex-Naval personnel in any other manner which the Naval Board may approve.
- (ii) The Central Canteen Fund will be financed, as indicated in A (iii), B (i) and C (ii) above, by a general levy on all H.M.A. Ships and Establishments from funds normally payable from canteen sources to the ship's fund.
- (iii) Further information regarding the composition of the Central Canteen Fund Committee, the general method of administration of the Central Fund, etc., will be promulgated in Navy Orders in due course.

E.—USE OF ARMY HOSTELS AND OFFICERS' CLUBS BY NAVAL PERSONNEL.

The Department of the Army has agreed to extend the full use of the Australian Army Canteens Service Hostels and Officers' Clubs to Naval personnel, available sleeping accommodation being apportioned between Naval and Army personnel having regard to the strengths of the respective Services in each locality.

APPENDIX.

AUSTRALIAN ARMY CANTEENS SERVICE ISSUING POINTS AT WHICH BULK SUPPLIES WILL BE AVAILABLE FOR NAVAL PURPOSES.

NEW GUINEA—

Port Moresby
Milne Bay
Dobodura
Lae
Merauke

QUEENSLAND—

Brisbane
Maryborough
Rockhampton *closed 17/11/44*
Townsville
Cairns
Thursday Island
Jacky Jacky (Red Island Point) *closed 14/11/44*

NEW SOUTH WALES—

Sydney
Wollongong

VICTORIA—

Melbourne
Geelong
Point Lonsdale

SOUTH AUSTRALIA—

Adelaide

WESTERN AUSTRALIA—

Perth
Claremont
Rottnest
Broome

NORTHERN TERRITORY—

Darwin
Adelaide River

TASMANIA—

Hobart
Launceston

(427/201/828.)

(This Order will be reprinted for posting on Notice Boards.)

By Authority: H. E. DAW, Government Printer, Melbourne.

RESTRICTED.(FOR OFFICIAL USE ONLY.)

Commonwealth Navy Orders.

Navy Office, Melbourne,

19th September, 1944.

The following Orders, having been approved, are hereby promulgated for information and guidance, and necessary action.

By direction of the Naval Board,

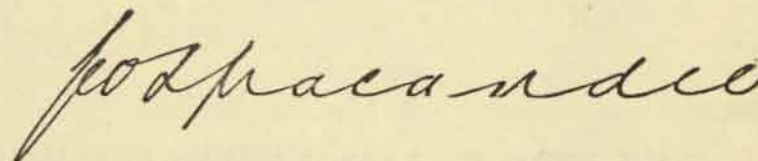

Secretary.

*The Commodore Commanding H.M.A. Squadron,
and Commanding Officers of H.M.A. Ships,
Officers in Charge of H.M.A. Naval
Establishments, and others concerned.*

TABLE OF CONTENTS.

No.	Subject.
485.	Minor War Vessels taken up for War Service.
486.	40 M.M. Bofors Mk. I and I* (Naval) Australian Manufacture.
487.	Ammunition—20 M.M. Oerlikon H.E.—Lot T.P.C. 746—Withdrawal.
488.	Test Lamp for Domestic Automatic Refrigerators.
489.	Medical and Dental Stores—Supply of, in the New Guinea Area.
490.	Correction of Charts in H.M.A. Ships.
491.	Transfer of Naval Stores on Permanent Loan.
492.	Repayment Clothing in Tenders.
493.	Uniform and Clothing Supplies—Repayment Issues of Materials.
494.	Working Suits—Officers Carrying out Duties of Gunners.
495.	Special Clothing Issues for Personnel in Forward Island Areas.
496.	Safety Razor Blades—Gratuitous Issues of.
497.	Penicillin—Care and Custody of.

C.10133/44

485.

MINOR WAR VESSELS TAKEN UP FOR WAR SERVICE.

Approval has been given to the provision of 10-in. Signalling Projectors, in accordance with C.A.F.O. 2359/43, for minor war vessels taken up for war service, provided sufficient power is available.

2. It is not desired that vessels already equipped with efficient arc type Projectors should be supplied with Pattern 3860A Projectors in lieu.

3. Supply to vessels concerned will be effected by the Superintending Naval Store Officer, Sydney.

(674/201/1936.)

486.

40 M.M. BOFORS MK. I AND I* (NAVAL) AUSTRALIAN MANUFACTURE.

The following modification has been approved for guns not so fitted:—

Gun.—40 m.m. Bofors.

Part affected.—Left casing, rear.

Purpose.—To fit Bracket, catch, rear; Hand-operating lever; for housing hand-operating lever when loading.

Nature of modification.—Prepare casing for the Bracket, catch, rear, in accordance with diagram (D.O.T.M. 78689), appended to this Order.

New parts required.—Bracket, catch, rear, Hand-operating lever A.N.115 complete with 2 No. $\frac{3}{8}$ Whit. Securing Screws (to be supplied when available). Dust Cover, A.N.14414.

By whom to be done.—Casing, to be prepared and a Dust Cover fitted by Armament Depot only. Ship's Staff and Base Ordnance Staffs to fit Bracket, catch, rear, when received.

Drawings.—D.O.T.M. 78689 and D.O.T.M. 78683, appended to this Order.

Degree of urgency.—Every opportunity should be taken to prepare Casings for Bracket, catch, rear.

2. Pending receipt of Bracket, catch, rear, a temporary stop as shown in diagram (D.O.T.M. 78683), appended to this Order, is to be fitted by Ship's staffs, Base Ordnance Staffs and Armament Depots.

(490/212/1141.)

LIST OF COMPONENTS.		ITEM	DESCRIPTION.	No
1	MOD. TO CHART NO. 14408			
2	805.1. / 851. (LOW)			1
3	825.1. / 851. (HIGHER)			2

ORDNANCE, Q.F., 40 MM., MKS. I AND I*
 FITTING OF TEMPORARY STOP, LOADING POSITION, FOR HAND OPERATING LEVER.

D.O.T.M. 78683

7.1.42

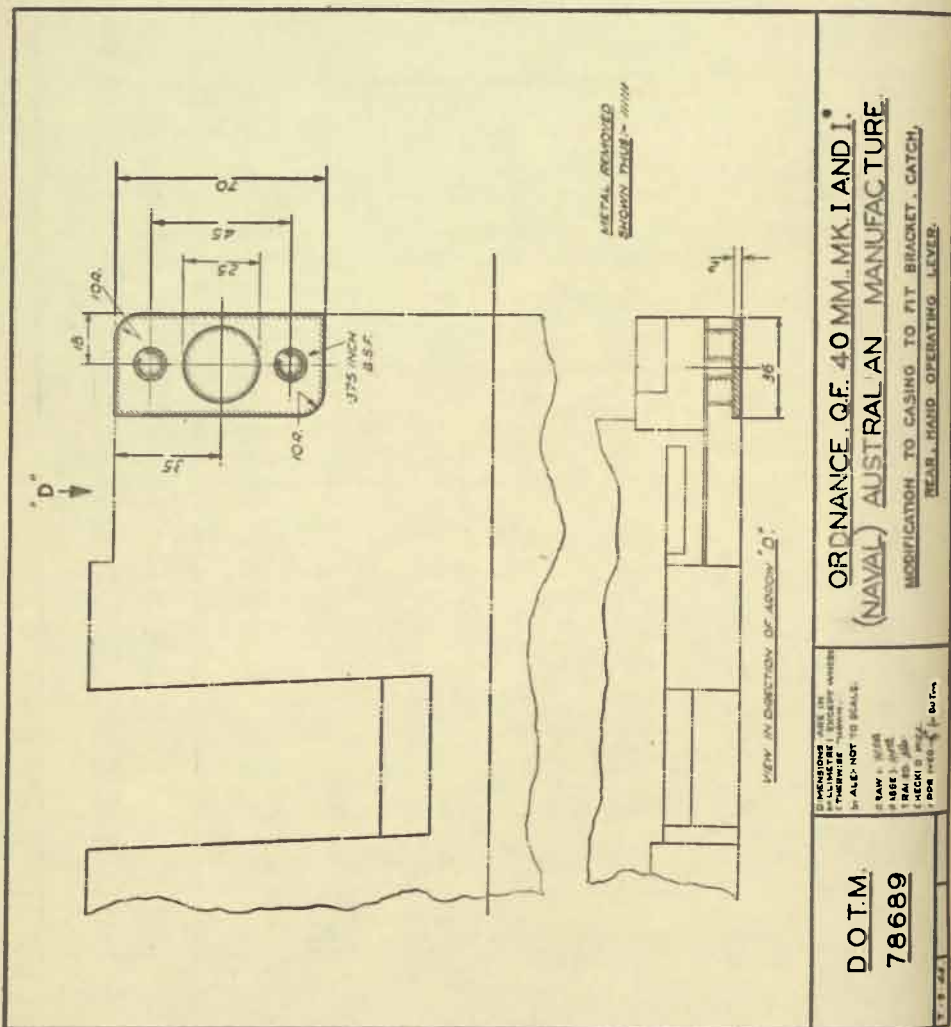

487.

AMMUNITION—20 M.M. OERLIKON H.E.—LOT T.P.C. 746
—WITHDRAWAL.

Appended, for information and necessary action, is copy of Admiralty Fleet Order 3398/44 which has not yet been promulgated on the Australia Station:—

“20-m.m. Oerlikon H.E. ammunition of lot T.P.C. 746 has caused stoppages owing to the caps of the cartridges blowing out when using Mark II breech face pieces and is to be withdrawn from service.

2. All Oerlikon H.E. ammunition of this lot on board ships is to be returned to the nearest Naval Armament Depot or Officer-in-Charge of Armament Supply at the first opportunity and ammunition of other lots drawn in lieu.

3. D.E.M.S. Staff Officers are to arrange for similar action to be taken in merchant ships.

4. H.E. ammunition of this lot in store at Naval Armament Depots or subsequently received should be brought to produce.”

(408/206/1455.)

488.

TEST LAMP FOR DOMESTIC AUTOMATIC REFRIGERATORS.

It has been decided to provide 1 No. “Halide” Leak Testing Lamp to each of H.M.A. Cruisers, L.S.I’s., Destroyers, Sloops, Frigates, A.M.S. Vessels and H.M.A.S. *Moresby*, for use in connection with the maintenance of Domestic Automatic Refrigerators.

2. Provision has also been made for supply of the above-mentioned item to the following Bases, for use in testing Domestic Automatic Refrigerators of vessels based thereon:—

Sydney	Darwin
Brisbane	Fremantle
Townsville	Port Adelaide
Cairns	Port Melbourne
Milne Bay	Port Moresby.

3. Arrangements have been made for supply of Leak Testing Lamps to H.M.A. Ships and Bases referred to above to be effected without demand by the Superintending Naval Officer, Sydney.

4. The Lists of Special Allowances for H.M.A. Ships and Establishments of Naval Stores for Bases, indicated above, should be amended accordingly.

(524/201/2600.)

489.

MEDICAL AND DENTAL STORES—SUPPLY OF, IN NEW GUINEA AREA.

Demands from Ships and Depots in New Guinea area are to be made on Naval Medical Store, Milne Bay, and not on the Medical and Dental Store Officer, Sydney, or U.S.A. sources. Until such time as dental stores are held at the Medical Store, Milne Bay, demand for these is to be made on the Medical and Dental Store Officer, Sydney.

2. In cases of extreme emergency, when stores cannot be obtained from R.A.N. sources, a small demand to meet the particular case only may be made on the Australian Army or R.A.A.F. Store in the area.

3. In future, all medical and dental stores obtained from any *Allied* force will be treated as the personal responsibility of the member making the demand.

4. It is to be noted that medical and dental stores previously supplied to the Royal Australian Navy from Allied sources, for which a signature has or has not been given, have been the subject of a claim for financial recovery from the Royal Australian Navy.

(612/213/2669.)

490.

CORRECTION OF CHARTS IN H.M.A. SHIPS.

The provisions of A.F.O. 2137/1941 are applicable to R.A.N. Cruisers but the allowance of 3d. per diem is not to be paid without prior Naval Board approval.

2. Application for payment of the allowance should only be made when it is considered that a rating is employed on this work to an extent which justifies the allowance.

3. The necessary amendment to Naval Financial Regulations and Instructions has been made by R.I. 7/44.

(407/201/1097.)

491.

TRANSFER OF NAVAL STORES ON PERMANENT LOAN.

With reference to Navy Order 610 of 1943, recent investigations into the circumstances regarding losses of Naval Stores have disclosed that, on transfer of officers to whom Naval Stores have been issued on Permanent Loan, the items have not been promptly mustered by the incoming officer, and the requisite certificate signed in the standard copy of the Permanent Loan List.

2. The attention of all concerned is drawn to B.R.4, Article 52, which is reprinted hereunder:—

“52. **Transfer of Officers—Receipts for Stores on Permanent Loan.**—When an officer or rating, to whom stores have been issued on permanent loan, is relieved of his particular duties, the Commanding officer is to ensure that steps are taken to have the stores on loan returned to the Accountant (Storekeeping) Officer or verified from the lists held by the latter. Persons associated in the verification are normally to be the individual giving up charge

and the one to whom the stores are to be transferred for custody, or an officer deputed by the Commanding Officer to take temporary charge of them pending the arrival of the person to whom they will be eventually transferred.

(2) When, owing to the large number of items involved, it is found impossible for this verification to be completed concurrently by the persons concerned, the one giving up charge is to note on the lists details of known differences, and the one assuming charge may be allowed up to one month to complete his verification.

(3) The person to whom the stores are transferred is to sign the certificate on all copies of the loan lists, certifying their accuracy.

(4) If any differences are disclosed, the procedure outlined in Chapter XI is to be followed, an explanation in writing being obtained from the person giving up custody of the stores.”

3. Action is to be taken by responsible officers to ensure that all current Permanent Loan Lists have been verified and signed by Officers now in charge of stores, and that in future the transfer of stores and signing of the appropriate certificate is completed in accordance with the Regulations.

(612/212/3052.)

492.

REPAYMENT CLOTHING IN TENDERS.

With reference to Navy Order 664 of 1943, it is now approved, for the remainder of the war period, that Destroyers, Frigates, Sloops and A.M.S. Vessels, when operating in forward areas, including Northern Territory, may maintain for emergency issue on repayment a limited quantity of each of the following articles, in addition to soap and cap ribbons which only have hitherto been authorized:—

Boots, leather.	Stockings.
Brushes, tooth.	Shorts, khaki.
Caps, white duck.	Shirts, khaki.
Shoes, black leather.	Towels, white.
Singlets.	Cap covers, khaki.
Socks.	Suits, combination.

2. The maximum quantities to be maintained are not to exceed one month's estimated requirements of each article, and issues should be confined to occasions when individual requirements are not obtainable from either the parent ship or other H.M.A. Ship or Naval Establishment where an Accountant Officer is borne. To guard against deterioration in small ships, however, all articles in store should, as a general rule, be issued within three or four months from date of receipt.

3. Commanding Officers concerned are to ensure that such stores are placed in a suitable secure stowage space. They will be directly responsible for the safe custody of and satisfactory accounting for such stores (*vide* K.R. and A.I., Article 1853A.) and that, where applicable, the general procedure specified in C.O.R., Article 481, is observed. In this regard, Form A.S.1048 is to be used as a credit voucher in Form A.S.462 (Parts II and III), thereby dispensing with Form A.S.107. As

far as is possible, issues should be restricted to once weekly, and then only in the circumstances stated in paragraph 2 above. Cash takings for sales recorded in Form A.S.1048 are to be paid by Commanding Officers at the first opportunity to the Accountant Officer of any H.M.A. Ship or Establishment, the official receipt obtained being affixed to the Credit Voucher (Form A.S.1048). The cash taken for sales of clothing is never to be left in the custody of the supply rating after an issue has taken place. It is always to be handed over to an officer for custody and should be checked by an officer with Form A.S.1048 to ensure that the correct charge is made for each item and that the gross total is correct. The form should be signed by the supply rating making the issue and by the officer receiving the cash.

4. Stocks of repayment clothing are to be checked at least once a month, and a monthly certificate of stocktaking is to be signed by the Commanding Officer, or officer delegated by him for victualling duties, and attached to Form A.S.462 (Parts II and III) for subsequent rendition to Navy Office. In this respect opportunity is to be taken by parent ships for stocktaking to be carried out in accordance with paragraph 3 of Navy Order 373 of 1941.

5. The necessary forms should be obtained by demand in the usual manner, or in an emergency from the Accountant Officer of a ship or establishment. Additional copies of the Clothing Price List should, if required, be obtained from the Director of Victualling, Navy Office.

6. The attention of all concerned is drawn to Navy Orders 374 of 1942 and 464 of 1943 in their general relation to clothing articles issued on repayment.

(434/201/3523.)

493.

UNIFORM AND CLOTHING SUPPLIES—REPAYMENT ISSUES OF MATERIALS.

In order to conserve stocks of materials, the procurement of adequate supplies of which is still difficult, repayment issues of the following items included in the "Official Memorandum—Prices of Clothing, &c., maintained for issue on repayment to Ships' Companies", dated 1st May, 1944, are to cease forthwith:—

- Cloth, beaver, for greatcoats.
- Cloth, blue No. 3, for greatcoats.
- Cloth, for Officers' uniforms.
- Drill, khaki.
- Drill, white.
- Dungaree, blue.
- Dungaree, brown.
- Duck, white.
- Fearnought.
- Flannel, heavy and light.
- Serge, blue, lightweight.
- Serge, diagonal.
- Serge, seamen's.
- Shirting, cotton, blue and white stripes.
- Shirting, for tropical shirts, singlets, also for cotton flannels.
- Shirting, khaki.

2. Such prohibition is not to apply to the issue of $\frac{1}{4}$ -yd. pieces of materials required for repairs to garments, and stocks in excess of six months' anticipated requirements for that purpose are to be returned to the nearest victualling establishment at the first convenient opportunity.

3. It is intended that, for the balance of the war period, agreements for the supply of officers' uniforms, and contracts for ratings' made-to-measure uniforms, which are current in the capital city of each State, shall be utilized for all such future requirements, the necessary materials, linings and trimmings for making-up having been supplied to the firms concerned by the Department for that purpose. Details of the agreements and contracts are set out in Navy Orders 405, 406 and 407 of 1944.

4. Navy Order 674 of 1943 is cancelled.

(433/201/813.)

(This Order will be reprinted for posting on Notice Boards.)

494.

WORKING SUITS—OFFICERS CARRYING OUT DUTIES OF GUNNERS.

The provisions of A.F.O. 618/1944 are adopted for application in the R.A.N.

2. Combination suits (2 No. per annum) may be issued in lieu of the material. The sizes are the same as those set forth in Navy Order 180 of 1942.

(434/214/564.)

495.

SPECIAL CLOTHING ISSUES FOR PERSONNEL IN FORWARD ISLAND AREAS.

The special clothing authorized in Navy Order 623 of 1943 for gratuitous issue to personnel serving on shore in Forward Island Areas is, in future, to be issued to personnel *on arrival* and steps are to be taken to ensure that stocks are maintained for the purpose. Paragraph 2 of Navy Order 623 of 1943 is cancelled.

2. The heavy boots included in the gratuitous issue are, in future, to comprise the Army type boot.

(420/201/1098.)

496.

SAFETY RAZOR BLADES—GRATUITOUS ISSUES OF.

In order to reduce to a minimum the time and labour involved in gratuitous issues of safety razor blades, it has been decided that the scale of issue to all Naval personnel borne in ships and shore establishments shall be one packet of five blades every six weeks. Issues on this amended basis are to commence in all ships and establishments on the first fortnightly pay day in November (which normally would be Thursday, the 9th) subsequent issues being made every six weeks and on no other occasion except in the case of personnel absent on account of sickness, leave or other contingency at the time of general issue. For this purpose up to four and a half months' anticipated requirements of blades, i.e., three general issues, may be held.

2. A separate voucher is to be completed after each issue for transmission with the Clothing Account.

(516/201/673.)

497.

PENICILLIN—CARE AND CUSTODY OF.

Thefts of Penicillin have been reported from one of H.M.A. Naval Establishments. As this drug has a marketable value, all possible precautions are to be taken to avoid loss.

2. Either the refrigerator in which the Penicillin is stored or the compartment which houses the refrigerator, or both, are to be locked when not in use, and the key or keys retained by the Senior Medical Officer or his deputy, or alternatively placed on the Key Board under charge of the sentry.

3. Stocks of Penicillin are to be mustered at frequent intervals, and any loss immediately reported to the Commanding Officer of the Ship or Establishment and also to the Director of Naval Medical Services.

(612/213/2746.)

RESTRICTED.(FOR OFFICIAL USE ONLY.)

Commonwealth Navy Orders.

Navy Office, Melbourne,
26th September, 1944.

The following Orders, having been approved, are hereby promulgated for information and guidance, and necessary action.

By direction of the Naval Board,

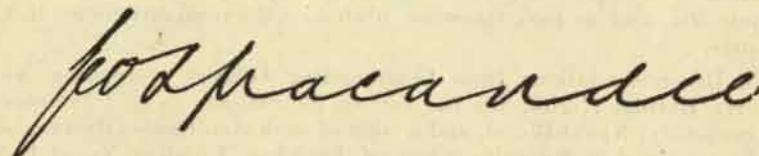

Secretary.

*The Commodore Commanding H.M.A. Squadron,
and Commanding Officers of H.M.A. Ships,
Officers in Charge of H.M.A. Naval
Establishments, and others concerned.*

TABLE OF CONTENTS.

No.	Subject.
498.	Naval Officer-in-Charge, Broome.
499.	Promotion of Naval Reserve Ratings to Warrant Rank.
500.	Professional Examination for the Rank of Warrant Electrician. R.A.N.
501.	Radio Mechanic Branch—Messing in Small Ships.
502.	W/T, A/S, Radar, &c. Equipment—Establishment Lists.
503.	Savealls Under Motor Boat Engines.
504.	Weir Type Feed Pumps.
505.	Guns 20 mm. Oerlikon—Adaptor for American Pattern Rods Cleaning and Ejecting—Introduction.
506.	Lockers for Damage Control Stores.
507.	Return of Naval Stores and Defect List Items to Sydney and Other Naval Store Depots.
508.	Contracts for the Supply of Ratings' Made-to-Measure Uniforms.
509.	Musical Instruments—Bugles.
510.	Form A.M. 301z—Medical Rehabilitation Advice Form.
511.	Books and Forms.

498.

NAVAL OFFICER-IN-CHARGE, BROOME.

The Naval-Officer-in-Charge, Port Headland, has been transferred to Broome as from 14th September, 1944.

2. Communications are to be addressed accordingly.

3. The appointment of Naval Officer-in-Charge, Port Hedland, is abolished.

(1937/2/233.)

499.

PROMOTION OF NAVAL RESERVE RATINGS TO WARRANT RANK.

The Naval Board have had under consideration the promotion of Naval Reserve Ratings to Warrant rank during wartime. It has been decided that promotion to Warrant Rank of Naval Reserve Ratings during War be approved.

2. Naval Reserve Ratings qualifying for Warrant Rank will be required to comply with the conditions contained in K.R. and A.I., Article 307, and to pass the same professional examinations as R.A.N. Ratings.

3. Recommendations from Commanding Officers concerning Naval Reserve Ratings eligible for the various courses are to be forwarded to the Secretary, Naval Board, and a copy of such simultaneously furnished to the Commodore Superintendent of Training, Flinders Naval Depot.

(432/205/6025.)

500.

PROFESSIONAL EXAMINATION FOR THE RANK OF WARRANT ELECTRICIAN, R.A.N.

The next professional examination for the rank of Warrant Electrician will be held in March, 1945.

2. The Commanding Officers of H.M.A. Ships and Naval Establishments are requested to forward to Navy Office, not later than 1st January, 1945, the names of candidates desirous of sitting for this examination. Blank returns are required.

3. Before a candidate is allowed to take the examination his Commanding Officer is to ensure that he has fulfilled the conditions of K.R. and A.I., Article 314, clause 2.

(465/207/1251.)

(This Order will be reprinted for posting on Notice Boards.)

501.

RADIO MECHANIC BRANCH—MESSING IN SMALL SHIPS.

With reference to paragraph 16 of Navy Order 414 of 1943, in ships where an Artisans' Mess is not provided, Leading Radio Mechanics are to be accommodated in the Petty Officers' Mess, in accordance with K.R. and A.I., Article 626, clause 6.

(407/215/333.)

(This Order will be reprinted for posting on Notice Boards.)

502.

W/T, A/S. RADAR, ETC. EQUIPMENT—ESTABLISHMENT LISTS.

Attention is drawn to the necessity for early rendition of the particulars of Establishment Lists for W/T, A/S. Radar, &c. Equipment referred to in Navy Order 311 of 1944.

2. Action should be taken by responsible Officers in H.M.A. Ships and Bases concerned to expedite the despatch of the requisite information to the Superintending Naval Store Officer, Sydney.

(1903/2/938.)

503.

SAVEALLS UNDER MOTOR BOAT ENGINES.

It has come to notice that the savealls fitted under the engines of several motor boats have been deliberately punctured to facilitate the disposal of waste oil by means of the bilge pump.

2. This practice is to cease forthwith. It greatly increases the fire risk by making the detection of oil and petrol leakage more difficult. It also causes dirty bilges and consequent loss of time in cleaning whenever defects have to be made good.

3. Commanding Officers are to arrange for early inspections of all boats and if any punctured trays are found, repairs are to be effected and the bilges cleaned without delay.

4. Attention is drawn to Navy Order 238 of 1943.

(603/243/1788.)

504.

WEIR TYPE FEED PUMPS.

Several cases of irregular running and failure of the shafts of the above pumps have been reported.

2. Some of the failures have taken the form of severe cracking around the keyway of the shaft at the point of attachment of the impeller.

3. It is probable that failure has been aggravated by irregular running due to mis-alignment of the pumps.

4. On all occasions when the pumps are opened up for examination or refit, the shafts are to be carefully examined for signs of cracking and the alignment is to be checked and carefully adjusted in accordance with the directions given in A.F.O. 874/41.

(603/276/103.)

505.

GUNS 20 M.M. OERLIKON—ADAPTOR FOR AMERICAN PATTERN RODS CLEANING AND EJECTING—INTRODUCTION.

In order that rods cleaning and ejecting, of American pattern, for Oerlikon guns may be used with brushes cleaning, heads ejector, rag-ends cleaning, rod and gauges of British pattern, an adaptor has been introduced for use in the Royal Australian Navy, and will be allowed to all ships in the proportion of one per Mk. IV (American) rod, cleaning and ejecting.

2. The use of this adaptor will allow of the issue of British pattern accessories irrespective of the pattern of rods, cleaning and ejecting, held.

3. Ships with Mk. IV (American) rods are to demand adaptors from the nearest Naval Armament Depot or Base. Bases and Naval Armament Depots other than Sydney are to demand requirements from the Superintending Armament Supply Officer, Sydney.

4. The Mark IV (American) rod can be recognized by the fact that it is the only assembly in which the cleaning brush screws into the rag end and not directly on to the rod. Furthermore, the rag end and ejector head are approximately 7 inches long as compared with the British items which are approximately 3 inches long.

(612/203/2796.)

506.

LOCKERS FOR DAMAGE CONTROL STORES.

With reference to A.F.O. 344/44, ships concerned should raise the necessary demands on the Superintending Naval Store Officer, Sydney, without delay.

2. As indicated in paragraph (3) (a) of the A.F.O., ships which already possess suitable steel lockers, are not to demand new ones except to complete to the allowance given in the appendix.

(421/203/64.)

507.

RETURN OF NAVAL STORES AND DEFECT LIST ITEMS TO SYDNEY AND OTHER NAVAL STORE DEPOTS.

All cases and packages returned to Garden Island or any other Naval Store Depot, should contain a packing note or other identifying voucher. In the case of unserviceable stores being returned, a copy of the requisition for Survey Form A.S. 331 should be enclosed.

2. Packages, containing defect list items forwarded to Sydney for repair, should be clearly marked "The Superintending Naval Store Officer, Sydney, for ENGINEER MANAGER."

3. Instances have occurred of packages which have been forwarded to Northern Ports, being opened, repacked and returned to Garden Island minus the packing note or any identifying voucher.

(612/201/5566.)

508.

CONTRACTS FOR THE SUPPLY OF RATINGS' MADE-TO-MEASURE UNIFORMS.

With reference to paragraph 5 (e) of Navy Order 405 of 1944, it is notified that the following additional extra is permissible, viz.:—

Class II—

Extra charge.

Taping of bottoms of trousers, Seamen's Serge .. 0 0 6d.

(434/216/98.)

(This Order will be reprinted for posting on Notice Boards).

509.

MUSICAL INSTRUMENTS—BUGLES.

With reference to Admiralty Fleet Order 5632/43, stocks of bugles are now very low, and when these stocks are exhausted, no further issue will be made.

(612/205/1153.)

510.

FORM A.M. 301z—MEDICAL REHABILITATION ADVICE FORM.

This form has been established to facilitate compliance with Navy Order 336 of 1943. With the object of simplifying and co-ordinating the advice which the form is intended to convey from the Medical Board of Survey to the Rehabilitation Officers, a Code Index system has been adopted which is to be used in conjunction with the Medical Rehabilitation Advice Form. If, after a trial period of three months, this Code Index proves of value, it will be permanently retained.

2. All R.A.N. Medical Officers will receive copies of the following:—

- (1) Directions for using Code Index; (2) Appendix "A"—List of the Commoner Diseases; (3) Appendix "B"—List of Industrial Handicaps and Affected Occupations. All Rehabilitation Officers will receive copies of (1) and (3) above but not (2).

3. Parts 1 to 6 inclusive of the Medical Rehabilitation Advice Form are to be completed by the Senior Medical Officer of the Final Medical Boards of Survey or his deputy, and forwarded to the Rehabilitation Officer of the Depot in which the survey has taken place.

4. In the event of the member being transferred to his home depot to await decision on the medical survey, the Medical Rehabilitation Advice Form is to be forwarded to the Rehabilitation Officer of the member's home port by the Rehabilitation Officer of the depot in which the survey was held. The Rehabilitation Officer of the depot from which final discharge is effected is to convey verbally to the invalided member, the information contained in parts 4, 5 and 6 of the form. In the case of paragraph 4, the advice given should be that laid down in the appropriate section of Appendix "B".

5. The symbol used on Form A.M. 301z to express disability is also to be inserted on Form A.M. 252z in reply to question 30.

6. A report on the value of this scheme will be asked for towards the end of 1944.

(480/201/3357.)

511.

BOOKS AND FORMS.

The under-mentioned forms have been introduced for use in the R.A.N. in lieu of the corresponding Admiralty forms. Supply will be made, on demand, by the Superintending Naval Store Officer, Sydney, when stock of the existing form is exhausted:—

A.S.1155 (7) } Destroyers' and Submarines' Fall of Shot and
A.S.1155 (7a) } Analysis Charts.

(480/202/4619.)

2. The under-mentioned form has been adopted for use in the R.A.N. and first supply will be made, without demand, by the Superintending Naval Store Officer, Sydney:—

S.1563.—Report of Failure of Ahead Throwing Weapons.

(A.F.O. 3501/43.)

(480/202/4481.)

RESTRICTED.(FOR OFFICIAL USE ONLY.)

Commonwealth Navy Orders.

Navy Office, Melbourne,

3rd October, 1944.

The following Orders, having been approved, are hereby promulgated for information and guidance, and necessary action.

By direction of the Naval Board,

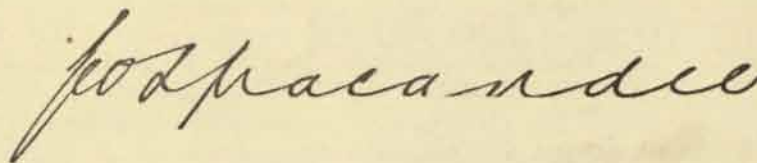

Secretary.

*The Commodore Commanding H.M.A. Squadron,
and Commanding Officers of H.M.A. Ships,
Officers in Charge of H.M.A. Naval
Establishments, and others concerned.*

TABLE OF CONTENTS.

No.	Subject.
512.	Accounts of R.A.N. Destroyers and A.M.S. Attached to Eastern Fleet.
513.	Senior Naval Officer, Combined Operations Section.
514.	Port Directors.
515.	Honours and Awards to R.A.N. Personnel.
516.	Leading Stoker Courses.
517.	H.M.A. Ships—Zinc Sheets and Underwater Protection of Ships and Fittings.
518.	A.M.S. Vessels—Main Circulating Water Inlet Pipes.
519.	Pistols, Revolver—Puff Shots.
520.	Exchange of Ammunition in A.M.S. Vessels.
521.	Vanadium Bearing Petroleum Ashes—Collection from Oil Burning Ships.
522.	Enemy Equipment.
523.	Books and Forms.

512.

ACCOUNTS OF R.A.N. DESTROYERS AND A.M.S. ATTACHED TO EASTERN FLEET.

The accounts of R.A.N. manned Destroyers attached to the Eastern Fleet, have been transferred to Accountant Officer (D) R.A.N., Eastern Fleet, whose office is for the present located in H.M. Naval Depot, Trincomalee (H.M.S. *Highflyer*).

2. The Accountant Officer (D) R.A.N., Eastern Fleet, is Base Accountant Officer for Destroyers, and all signals and correspondence relating to the pay, Victualling or Service Certificates of these Destroyers should be forwarded direct to that Officer.

3. (a) Signals should be addressed—

“Accountant Officer (D) R.A.N., Eastern Fleet.”

(b) Correspondence, Transfer Lists, &c., should be addressed—

“The Accountant Officer (D) R.A.N., Eastern Fleet, H.M.S. *Highflyer*, C/o British Fleet Mail.”

4. The R.A.N. Accountant Officer, Colombo, is borne on the books of H.M.A.S. *Bathurst*. His office carries out the following functions:—

(a) Base Accountant Office for A.M.S. Vessels, Eastern Fleet, and R.A.N. Pool in H.M.S. *Lanka*;

(b) Drafting Office for R.A.N. Destroyers and A.M.S. Vessels, Eastern Fleet, and R.A.N. Pool in H.M.S. *Lanka*;

(c) R.A.N. Education Centre for Eastern Fleet.

His address for correspondence and signals is—

“R.A.N. Accountant Officer, Colombo.”

5. Communications relating to personnel serving in R.A.N. manned ships of Eastern Fleet, whose actual ship is not known by ships or establishments in Australia, and private mail for ratings with no fixed ship address (e.g., ratings who have recently left Australia for disposal on arrival in R.A.N. pool in H.M.S. *Lanka*) should be sent C/o R.A.N. Accountant Officer, Colombo.

6. Navy Order 413 of 1944 is hereby cancelled.

(1804/2/84.)

513.

SENIOR NAVAL OFFICER, COMBINED OPERATIONS SECTION.

Appointment of Senior Naval Officer, Combined Operations Section has been approved.

2. His duties are—

(a) Act as Senior Officer of all R.A.N. Amphibious Units attached to 1st Australian Army Corps.

(b) Direct training of the above units.

(c) Carry out liaison duties on Amphibious matters with 1st Australian Army Corps.

3. The address of the Senior Naval Officer, Combined Operations Section is C/o the Naval Officer-in-Charge, Cairns.

(463/205/5821.)

514.

PORT DIRECTORS.

With reference to Navy Order 425 of 1944, a R.A.N. Port Director assumed duty at Hollandia on 18th September, 1944.

(1804/2/88.)

515.

HONOURS AND AWARDS TO R.A.N. PERSONNEL.

With reference to Navy Order 288 of 1944, the following additional Honours and Awards have been made to personnel of the Royal Australian Navy:—

For great skill and determination in a most hazardous enterprise:—

THE DISTINGUISHED SERVICE ORDER.

Lieutenant Maxwell Henry Shean, R.A.N.V.R.

2. For outstanding skill and determination in H.M.S. *Wildgoose* when six enemy submarines were destroyed by escort group of which his ship formed part in the course of operations covering the passage of convoys in the North Atlantic:—

THE DISTINGUISHED SERVICE CROSS.

Lieutenant Alan Vincent Atkins, R.A.N.V.R.

3. For undaunted courage in hazardous operations:—

THE DISTINGUISHED SERVICE CROSS.

Lieutenant Lloyd Russel Greentree, R.A.N.R.(S).

4. For great daring and enterprise:—

THE DISTINGUISHED SERVICE CROSS.

Lieutenant (Sp. Br.) Dick Crofton Horton, R.A.N.V.R.

Lieutenant (Sp. Br.) Henry Arthur Josselyn, R.A.N.V.R.

Lieutenant (Sp. Br.) John Robert Keenan, R.A.N.V.R.

Lieutenant (Sp. Br.) Alexander Nicol Anton Waddell, R.A.N.V.R.

Lieutenant (Sp. Br.) Malcolm Hugh Wright, R.A.N.V.R.

THE DISTINGUISHED SERVICE MEDAL.

Able Seaman Julius Bell Macnicol, O.N. B/V180.

Coder John Allen Payne, O.N. 24658.

MENTION IN DESPATCHES.

Coder John Andrew Kissane, O.N. 25651.

5. For outstanding courage, skill and devotion to duty in one of His Majesty's submarines:—

THE DISTINGUISHED SERVICE CROSS.

Lieutenant Donald Rupert Wilson, R.A.N.V.R.

6. For leadership and skill on convoy escort duty in H.M.A.S. *Ipswich*:—

THE DISTINGUISHED SERVICE CROSS.

Lieutenant Ronald Hugh Creasey, R.A.N.R.(S).

THE DISTINGUISHED SERVICE MEDAL.

Able Seaman James Nicholson, O.N. S/5465.

MENTION IN DESPATCHES.

Lieutenant Wallace William McQueen, R.A.N.V.R.

Leading Signaller William James Davies, O.N. B/2354.

7. For leadership, skill and devotion to duty in H.M.A.S. *Arunta* in a successful attack on an enemy submarine:—

THE DISTINGUISHED SERVICE CROSS.

Commander James Cairns Morrow, D.S.O., R.A.N.

Lieutenant Kenneth Ballieu Myer, R.A.N.V.R.

THE DISTINGUISHED SERVICE MEDAL.

Chief Petty Officer Nicholas Xavier Dix, O.N. 6678.

MENTION IN DESPATCHES.

Mr. Frank Hector Redvers Ley, Commissioned Gunner (T),
R.A.N.

Chief Engine Room Artificer Alfred Cecil Pearce, O.N. 10275.

Shipwright 4th Class Alexander Wooldrage, O.N. PM/4298.

Acting Leading Seaman Douglas Henry Kingdom, O.N. 22859.

8. For gallantry and distinguished service in special operations:—

THE DISTINGUISHED SERVICE CROSS.

Lieutenant Kenneth Murray Uhr-Henry, R.A.N.V.R.

MENTION IN DESPATCHES.

9. (a) For skill and devotion to duty in H.M.S. *Spey* in successful actions with "U" boats whilst on convoy escort duties in the Atlantic:—

Sub-Lieutenant Victor Douglas Valentine, R.A.N.V.R.

Able Seaman John Henry Dodd, O.N. S/4321.

- (b) For outstanding zeal and devotion to duty in operations which led to the capture of the Western end of New Britain:—

Acting Commander John Francis Rayment, D.S.C., R.A.N.

- (c) For great daring and enterprise:—

Coder Phillip Francis Wallander, O.N. 25651.

- (d) For good service in saving lives and valuable material in a heavy air raid on Bari:—

Sub-Lieutenant Leo Vincent Cruise, R.A.N.V.R.

- (e) For leadership and skill in convoy escort duty in H.M.A.S. *Launceston*:—

Acting Lieutenant-Commander Percy Goldsworthy Collins,
R.A.N.V.R.

Able Seaman James Edmund Mallam, O.N. S/6101.

- (f) For outstanding courage, leadership, resource and determination during assault on Anzio, and in subsequent bombardments in support of the Army, and in maintaining an unbroken flow of supplies which accomplished the building up of the beachhead despite bombing and bombardment by shore batteries:—

Lieutenant Edwin Joseph Gregg, R.A.N.V.R.

- (g) For courage and undaunted devotion to duty:—

Lieutenant Leon Verdi Goldsworthy, G.M., R.A.N.V.R.

MENTION IN DESPATCHES.

(POSTHUMOUS.)

10. (a) For gallantry, skill, determination and undaunted devotion to duty during the initial landing of Allied Forces on the coast of Normandy:—

Sub-Lieutenant Richard Pirrie, R.A.N.V.R.

- (b) For gallantry and distinguished service:—

Sub-Lieutenant Cornelius Lyons Page, R.A.N.V.R.

KING'S BIRTHDAY HONOURS, 1944.

O.B.E.

11. Acting Commander Rupert Basil Michael Long, R.A.N.

M.B.E.

Lieutenant-Commander Neville Drake Pixley, R.A.N.V.R.

Mr. Ralph Lane, Commissioned Telegraphist, R.A.N.

FOREIGN AWARDS AND DECORATIONS.

12. For gallantry in action at Rendova, Solomon Islands, on 30th June, 1943. Landing with the attacking echelon of an infantry battalion to establish a beachhead at Rendova, Lieutenant Rhoades led the assault wave of American troops in a charge on the Japanese defenders. As the result of his vigorous and courageous leadership, hostile forces at Rendova Plantation were struck before they were fully prepared, and were completely routed. Lieutenant Rhoades personally accounted for at least seven of the sixty-five Japanese who were killed in the attack:—

THE SILVER STAR.

(Conferred by the President of the United States of America.)

Lieutenant (Sp. Br.) Frederick Ashton Rhoades, R.A.N.V.R.

13. For service in the Greek Navy:—

GREEK WAR CROSS 3RD CLASS.

(Conferred by the King of Hellenes.)

Lieutenant Terence Collins, R.A.N.V.R.

(448/201/1507.)

(This Order will be reprinted for posting on Notice Boards.)

516.

LEADING STOKER COURSES.

Leading Stoker Courses have now been resumed at Flinders Naval Depot.

2. Navy Order 83 of 1942 is cancelled.

(600/205/450.)

(This Order will be reprinted for posting on Notice Boards.)

517.

H.M.A. SHIPS—ZINC SHEETS FOR UNDERWATER PROTECTION OF SHIPS AND FITTINGS.

In view of the improved supply position in relation to zinc, it has been decided to revert to the normal practice of using zinc sheets for underwater protection of ships and fittings.

2. Demands for requirements of zinc sheets should be forwarded to the nearest Storing Yard where supplies will be made available as early as practicable.

3. Navy Order 393 of 1944 is cancelled.

(532/201/1164.)

518.

A.M.S. VESSELS—MAIN CIRCULATING WATER INLET PIPES.

Frequent reports have been received from A.M.S. Vessels regarding rapid deterioration of the above pipes.

2. Where severe wastage is found in the bend of the existing pipe adjacent to the gunmetal casting connected to the pump discharge, arrangements should be made for the pipe to be shortened and a new cast bend interposed, with a mild steel corrosion piece connected to the shortened copper pipe, as shown in the appended drawing No. 910200,

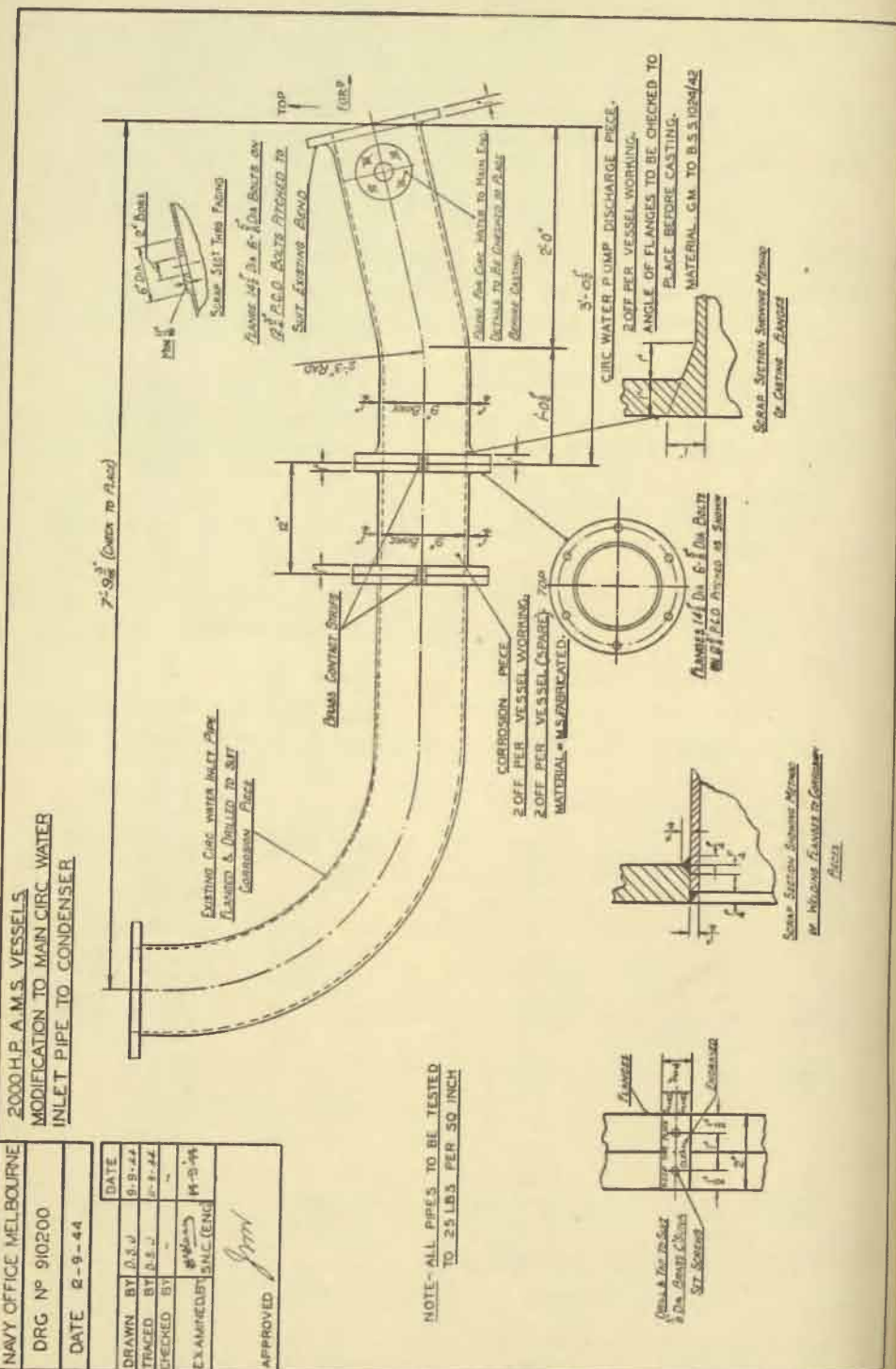

3. When this work is carried out, the remaining length of copper piping is to be thoroughly coated internally with "Debecote," or if this is not available, "Apexior No. 3." A small stock of "Debecote" is available in Sydney. A similar direction was promulgated in Navy Office Letter No. 61194 of 27th August, 1942.

4. The steel corrosion lengths are to be standardized at 12 inches overall length in order to facilitate manufacture and fitting of replace lengths.

5. Sufficient reports have not been received at Navy Office to enable the severity of wastage in both classes of A.M.S. vessels to be assessed, and drawing No. 910200 has been drawn only for 2000 I.H.P. Ships.

In 1750 I.H.P. Ships, the inlet pipe is straight for about 3 feet in length from the circulating pump bend and it is not anticipated that the attack will be so severe as in the bent pipe in 2000 I.H.P. Ships.

6. Where corrosion is experienced in pipes of 1750 I.H.P. Ships, the pipes should be shortened by 12 inches at the inlet end and mild steel corrosion pieces inserted, the remaining length of copper piping being treated as in paragraph 3.

7. The Commanding Officers of A.M.S. vessels concerned are to submit an item in the next supplementary defect list for the work to be carried out.

8. Attention is directed to the necessity for running the circulating pumps at the minimum speed required for efficient operation of the main machinery. Excessive speeds serve no useful purpose, and result in accelerated wastage of piping and condenser tubes.

(603/267/1535.)

519.

PISTOLS REVOLVER—PUFF SHOTS.

Cases of Puff shots have occurred recently when firing pistols revolver .455-in.

2. Naval Officers-in-Charge are to ensure that the instructions in B.R. 161/39, R.N. Handbook of Small Arms Courses, Chapter II, paragraph 2 (XV) and Admiralty Fleet Order 3148/44 are brought to the notice of Commanding Officers of all attached vessels.

(412/204/242.)

520.

EXCHANGE OF AMMUNITION OUTFITS IN A.M.S. VESSELS.

With reference to Navy Order 325 of 1944, A.M.S. vessels proceeding to Port Adelaide for refit are to arrange for ammunition outfits to be exchanged at Sydney or Fremantle either before or after refit. This instruction does not apply to depth charges for which facilities are available at Port Adelaide.

2. This will obviate considerable transport as large stocks of ammunition are not maintained at Port Adelaide.

(408/201/2138.)

521.

VANADIUM BEARING PETROLEUM ASHES—COLLECTION FROM OIL BURNING SHIPS.

With reference to A.F.O. 591/1944, attention is called to Navy Order 244 of 1942 regarding the collection of petroleum ash from the furnaces, &c., of oil burning H.M.A. Ships and Fleet Attendant Tankers, &c.

2. In view of the vital importance of the recovery of vanadium, special attention is to be paid to the collection of the vanadium bearing ashes and to the endorsement of supply notes in accordance with Navy Order 244 of 1942.

3. It should be noted that furnace oil fuel obtained from cargoes loaded at Aruba, Netherlands West Indies, is produced almost entirely from Venezuelan crude and is therefore rich in vanadium.

(482/202/1911.)

522.

ENEMY EQUIPMENT.

Any officer or man who comes into possession of any property of a member or unit of the armed forces of the enemy or any property which may have formed part of the arms, clothing or equipment of a member or unit of the armed forces of the enemy, is to forward such property to his Commanding Officer.

2. The Commanding Officer, if he is of the opinion that the property forwarded may be of value for Intelligence or Naval historical records purposes, is to forward it through the most convenient Service channels to the Director of Naval Intelligence, Melbourne, accompanied by a complete description of the circumstances of its acquisition. If the Commanding Officer is of the opinion that the property has no value for these purposes, it is to be returned to the personnel forwarding it.

3. All personnel should be warned at regular intervals that the greatest care should be taken at all times when securing, handling or receiving enemy equipment, so that possible "booby traps" may be avoided.

(635/201/1679.)

523.

BOOKS AND FORMS.

The under-mentioned forms have been introduced for use in the Royal Australian Navy in lieu of the corresponding Admiralty forms. First supply will be effected, without demand, by the Superintending Naval Store Officer, Sydney—

Convoy form A.D.

Convoy form A.M.

Convoy Forms A and B1 are obsolete.

(1954/2/405.)

2. Stocks of the under-mentioned forms are now held by the Superintending Naval Store Officer, Sydney, instead of at Navy Office. Supply will be effected, on demand, by that authority—

Report of Lighting of Vessels at Sea.

B.M.S. C.B.(1).

B.M.S. C.B.(2).

Register Sheet for C.B. form "R."

(480/201/3332.)

RESTRICTED.

(FOR OFFICIAL USE ONLY.)

Commonwealth Navy Order.

Navy Office, Melbourne,
3rd October, 1944.

The following Order, having been approved, is hereby promulgated for information and guidance and necessary action.

By direction of the Naval Board,

J. O. Macarandee
Secretary.

*The Commodore Commanding H.M.A. Squadron,
and Commanding Officers of H.M.A. Ships,
Officers in Charge of H.M.A. Naval
Establishments, and others concerned.*

TABLE OF CONTENTS.

No.	Subject.
524.	R.A.N. Education Service—Reconstruction Training Scheme. C.10606/44.

524.

R.A.N. EDUCATION SERVICE: RECONSTRUCTION TRAINING SCHEME.

Under the Reconstruction Training Scheme, instruction by correspondence in a wide range of subjects is now available through Universities, Technical Colleges, State Education Authorities, and some other institutions. The subjects at present available are listed in an Appendix to this Order and amendments to this Appendix will be promulgated as new courses are added.

2. Education Officers have been appointed to the principal bases and to cruisers and should be consulted in regard to any difficulties and enquiries arising in connection with the Reconstruction Training Scheme and also in regard to other facilities available through the R.A.N. Education Service.

3. In ships and establishments in which an Education Officer is not borne, the Commanding Officer is to detail an Acting Education Officer who is to accept applications for correspondence courses and carry out liaison duties with the Base Education Officers.

4. *Procedure of Enrolment.*—All applicants for instruction must complete a General Information Form in duplicate and forward both original and duplicate copies of this form to the Director of Education and Vocational Training, Navy Office, Melbourne, through their Commanding Officer.

5. When possible, General Information Forms should, before being forwarded, be referred to the Base Education Officer who is to check the course desired and the eligibility of the applicant. When eligibility has been checked, an Enrolment Form should be completed and forwarded together with the General Information Form.

6. Enrolment Forms together with the Authority to Debit Ledger Account with Fee Deposit are to be completed in duplicate, the Education Officer verifying the fact that the correct name of the subject or subjects as shown in the Appendix to this Order is inserted in the space provided, the correct stage indicated, and the correct figure inserted in the space for amount to be charged in Ship's Ledger. Both copies of the form are to be signed and approved as indicated, the duplicate copy being retained in the ship or establishment for future reference and the original forwarded to the Director of Education and Vocational Training, Navy Office, Melbourne.

7. The amount shown in the Authority to Debit Ledger Account with Fee Deposit is to be estimated on the pro rata basis of 15s. for each individual subject. Applications for more than three subjects will not be accepted. Henceforward the only method of payment of fee deposit is through the Ledger Account, and cash remittances should not be forwarded.

8. When an applicant is uncertain as to what course to take up, or when he desires to do a course that is not listed in the Appendix to this Order, the General Information Form only is to be completed and an Enrolment Form is not to be forwarded until advice of approval of enrolment has been received from the Director of Education and Vocational Training.

9. In the main, one subject is sufficient to keep a Service student fully occupied, and unless there are definite reasons to the contrary, his interests will be best served by his being enrolled for one subject

only. Candidates for university and public examinations may be enrolled for two subjects. In the case of the Sydney Technical College, it is desirable for some subjects to be studied concurrently. Subjects so affected are bracketed together. Although, in the main, the subjects listed hereunder are available to members of the Royal Australian Navy from all States, members are advised to enrol through their home State when possible.

10. *Procedure for debiting Pay Account.*—As soon as a member has been enrolled, a Form of Advice will be sent to his Commanding Officer. On receipt of this advice, the amount involved is to be charged against the pay account of the member in accordance with the Authority given in the Order, and the Director of Navy Accounts furnished, as early as possible, with a reference to recovery. The Fee Deposits will then be paid from Navy Office direct to the School concerned. Where the accounts of the Ship in which the member is borne and to which advice of enrolment is sent are kept elsewhere, the advice should be forwarded immediately to the Accountant Officer concerned for action.

11. On the satisfactory completion of each subject, the fee deposit paid will be refunded to the member through his ledger account on advice from Navy Office. In the event of his desiring to enrol for a further subject or subjects, the same procedure should be followed as for an initial enrolment.

12. This Order supersedes Navy Order 340 of 1943, which is hereby cancelled.

13. *Supply of Handbooks, Forms, Equipment and Text Books.*—A "Handbook for Education Officers" giving synopsis and details of the courses available through the Sydney Technical College has been distributed to all ships. Further sections of this book are being printed and will be distributed in due course. Supplies of General Information Forms and copies of the above Handbook can be obtained on request either from the Base Education Officer or from the Director of Education and Vocational Training at Navy Office.

14. Requests for text books should be made on an Order Form as laid down in Navy Order 287 of 1944. A text book order (*vide* Navy Order 287 of 1944) should be forwarded together with the Enrolment Form by members who wish to do Leaving Certificate and Intermediate subjects. In the case of Technical College subjects, when text books are required, the approximate price is shown in the Appendix alongside the name of the subject, and in respect of these subjects a text book order should be forwarded. Personnel may arrange for the purchase of books other than text books through the Services Book Supply Depot, Bent-street, Sydney, but it must be clearly understood that the provisions of Navy Order 287 of 1944 do not apply in this case and personnel will be required to make their own arrangements for forwarding the money.

15. Enquiries about other facilities that are available through the R.A.N. Education Service such as box libraries, maps, gramophone records, documentary films and sets of tools for pre-vocational training centres, should be made either through the Base Education Officer, or direct to the Director of Education and Vocational Training.

16. *Class Instruction.*—Where a candidate enrolls at a University, Technical College, or other approved institution and attends classes in subjects which are covered by correspondence courses, provision has

been made by the Department of Post-War Reconstruction for a refund of fees paid, up to a maximum of £5 10s. per year. Applicants desiring to enrol for class instruction should obtain the approval of their Commanding Officer and arrange their own enrolment in the same way as does a civilian. After enrolment, a General Information Form should be completed, endorsed "Enrolment for Class Tuition Effected," and forwarded to the Director of Education and Vocational Training. On the completion of the course of instruction, application for a refund of fees should be made through the Commanding Officer to the Director of Education and Vocational Training, who will, after investigating the eligibility of the applicant, take any necessary steps to have this refund effected.

17. *Matriculation.*—The various universities of the Commonwealth have agreed to give special consideration to Service personnel who apply for matriculation. Instead of being required to pass in all the prescribed subjects at one sitting, a member of the Services is allowed to present himself for examination in one or more subjects at a time. Subjects passed at a previous matriculation or leaving certificate examination may, under some circumstances, be taken into consideration.

18. *Examinations.*—Arrangements have been made for the supervision of university and other examinations under Service conditions. Personnel who are doing correspondence courses and who are eligible for examination will be notified and will be required to lodge an application with the Director of Education and Vocational Training not less than two months before the date of the proposed examination.

19. Examination papers will be forwarded through the Director of Education and Vocational Training to the Commanding Officer of the member with all necessary instructions. The completed examination papers will be properly sealed and returned in a confidential package to the Director of Education and Vocational Training at Navy Office.

20. When Service conditions do not permit a member to sit for examination at the exact time and date prescribed, he may sit at the first convenient opportunity within fourteen days of the prescribed date, provided his worked papers are accompanied by an adequate explanation on the part of his Commanding Officer, and a statutory declaration on his own part that he had no knowledge of the content of the papers at the time of his entry into the examination room.

21. As far as the requirements of the Service permit, Commanding Officers are to make provision for the proper conduct and supervision of examinations. It may sometimes be found convenient to land candidates who are serving in small ships so that suitable arrangements for the supervision of their examination may be made by the Base Education Officer.

22. A member doing any subject under the R.A.N. Education Scheme is entitled to complete that subject when demobilized. It is emphasized however that, if that subject forms part of a course, there is no guarantee that he will be able to obtain financial assistance to study further subjects of that course after discharge. The R.A.N. Education Service has no authority to say what course (if any) a member may do when demobilized. This is decided by the Regional Committee of the Central Reconstruction Training Committee when a demobilized member makes his application.

APPENDIX.

SUBJECTS AVAILABLE.

SECTION I.—SUBJECTS AVAILABLE THROUGH THE CORRESPONDENCE TEACHING DIVISIONS OF THE VARIOUS STATE EDUCATION DEPARTMENTS.

Name of Subject.	State in which Available.
<i>Primary Subjects, Grade</i>	Qld., S.A., Tas.

(These are composite courses comprising instruction in English, Arithmetic, History and Geography to Grade VII. Standard. The Grade at which instruction is desired should be stated.)

A satisfactory education up to the conclusion of the Primary Stage is a pre-requisite for enrolment in the following subjects. In applying for Western Australian and Queensland courses, the word "Junior" should be used instead of "Intermediate". It will be assumed that the applicant desires to begin study at the first year stage unless otherwise stated. Text-books will be required for the courses in Intermediate and Leaving Certificate subjects.

Name of Subject.	State in which Available.
<i>Intermediate—</i>	
<i>Agricultural Science</i>	Vic. (1st and 2nd year only).
<i>Algebra</i>	Qld., W.A., Vic. (1st and 2nd year only).
<i>Arithmetic</i> (see also " <i>Mathematics</i> ")	Vic., Qld., W.A., S.A.
<i>Art</i>	N.S.W. (S.A.—see courses in Section II.).
<i>Bookkeeping and Business Principles</i>	N.S.W.
<i>Bookkeeping and Business Methods</i>	Qld.
<i>Commercial Principles</i>	Vic.
<i>Drawing</i>	Vic.
<i>Drawing "A"</i>	W.A.
<i>Drawing "B"</i>	W.A.
<i>English</i>	N.S.W., Qld., S.A., W.A., Vic. (not 3rd year).
<i>English Expression</i>	Vic. (3rd year only).
<i>English Literature</i>	Vic. (3rd year only).
<i>French</i>	N.S.W., Vic., Qld., S.A.
<i>Geography</i>	N.S.W., Vic., Qld., S.A., W.A.
<i>Geometry</i>	Qld., W.A.
<i>German</i>	Vic.
<i>History</i>	N.S.W., Vic., Qld., W.A., S.A.
<i>Latin</i>	N.S.W., Vic., Qld., S.A.
<i>Mathematics I.</i>	N.S.W., S.A.
<i>Mathematics II.</i>	N.S.W., S.A.
<i>Mathematics (General)</i>	N.S.W.
<i>Mathematics A</i>	Vic. (3rd year only). (W.A. Students should enrol for 2 subjects Arithmetic and Algebra.)
<i>Mathematics B</i>	Vic. (3rd year only). (W.A. Students should enrol for 2 subjects Geometry and Trigonometry.)
<i>Shorthand</i>	Qld.
<i>Trigonometry</i>	W.A.

Remarks.—See also Sydney Technical College Preparatory Courses Stage I. which are equivalent to N.S.W. third year standard.

In the main, a pass at Intermediate Standard is a pre-requisite for enrolment in the following subjects. In applying for Queensland courses the word "Senior" should be used instead of "Leaving Certificate".

Name of Subject.	State in which Available.
<i>Leaving Certificate—</i>	
<i>Agricultural Science</i>	Vic.
<i>Arithmetic</i> (see also " <i>Mathematics</i> ") ..	S.A.
<i>Drawing</i>	Vic. (S.A.—see courses in Section II.).
<i>Economics</i>	Vic.
<i>English</i>	N.S.W., Qld., S.A., W.A., Vic.
<i>French</i>	N.S.W., Vic., Qld., S.A.
<i>Geography</i>	N.S.W., Vic., Qld., S.A., W.A.
<i>German</i>	Vic.
<i>History</i>	N.S.W., Vic., Qld., S.A., W.A.
<i>Industrial History and Economics</i> ..	W.A.
<i>Latin</i>	Vic., Qld., S.A.
<i>Mathematics</i>	N.S.W.
<i>Mathematics I.</i>	Vic., Qld., S.A.
<i>Mathematics II.</i>	Vic., Qld., S.A.
<i>Mathematics III.</i>	Vic.
<i>Mathematics A</i>	W.A.
<i>Mathematics B</i>	W.A.
<i>Mathematics, Applied</i>	W.A.
<i>Mechanics</i>	N.S.W.
<i>Physics</i>	W.A.

Remarks.—(a) N.S.W. Subjects—English, French, History, Geography, Mathematics and Mechanics are accepted for Matriculation purposes but do not necessarily conform to text book requirements for the N.S.W. Leaving Certificate.

(b) After March, 1945, Victorian Leaving Certificate courses will not be accepted for matriculation purposes and courses at a more advanced standard will require to be written.

(c) As text-books for many of the courses in the above groups change each year, enrolment in a large number of subjects will have to be deferred until the courses for 1945 have been written.

SECTION II.—SUBJECTS AVAILABLE THROUGH THE CORRESPONDENCE TEACHING. DIVISIONS OF THE VARIOUS TECHNICAL COLLEGES.

Literary Courses.

Name of Subject.	Approximate Price of Text-books.	State in which Available.
	<i>s. d.</i>	
<i>English Expressive</i>	6 0	Vic.
<i>English Preliminary</i>	1 9	Vic., S.A., W.A.
<i>Freelance Journalism</i>	4 3	Vic., S.A., W.A.

(N.B.—Before being enrolled for this subject, an applicant must submit a sample of work or complete "English Preliminary".)

Preparatory Courses.—These courses are designed for students with a good primary education who desire to bring their educational qualifications up to the required entrance standard for Technical College certificate and diploma courses. They are also recommended for members wishing to improve their general education without sitting for examinations. Subjects shown in brackets may be taken together.

Name of Subject.	Approximate Price of Text-books.	State in which Available.
	<i>s. d.</i>	
{ <i>Stage I. English</i>	14 1	} N.S.W.
{ <i>Stage I. Mathematics</i>	9 2	
{ <i>Stage II. English</i>	16 0	
{ <i>Stage II. Mathematics</i>	30 0	
{ <i>Mechanics (Stage II.)</i>	7 0	
{ <i>Stage III. English</i>	16 0	
{ <i>Stage III. Mathematics</i>	30 0	
{ <i>Mechanics (Stage III.)</i>	14 0	

N.B.—(Subjects in the last bracket are accepted as qualifying for matriculation for the University of Sydney.)

The following are Melbourne Technical College type Preparatory Courses. Lower Standard courses take students to the Junior Technical Certificate level; Higher Standard courses are equivalent, but should be taken by those who intend to proceed further with their studies.

Name of Subject.	Approximate Price of Text-books.	State in which Available.
	<i>s. d.</i>	
<i>Lower Standard—</i>		
<i>Arithmetic</i>	6 6	Vic., S.A., W.A.
<i>Mensuration</i>	6 6	Vic., S.A., W.A.
<i>Algebra</i>	—	Vic.
<i>Geometry</i>	—	Vic.
<i>Higher Standard—</i>		
<i>Arithmetic</i>	6 6	Vic., S.A., W.A.
<i>Mensuration</i>	6 6	Vic.
<i>Algebra</i>	—	Vic.
<i>Geometry</i>	—	Vic.
<i>Intermediate—</i>		
<i>Algebra (Technical)</i>	3 0	Vic.
<i>Geometry and Trigonometry (Technical)</i> ..	18 1	Vic.
<i>Trigonometry (Technical)</i>	—	Vic.
<i>Physics</i>	—	Vic., W.A.

N.B.—Subjects in the last group prepare students for courses at the Technical Grade I. level. They do not cover the syllabus for the Intermediate Certificate. (For Grade I. Mathematics see "Contributory Courses".)

Entrance Examination Courses.

Name of Subject	Approximate Price of Text-books.	State in which Available.
	<i>s. d.</i>	
<i>Nurses' Entrance</i>	7 4	N.S.W., Vic.
<i>Police Entrance</i>	7 4	N.S.W.
<i>Telephonists and Telegraph Messengers</i> ..	7 4	N.S.W.

The following occupational courses are grouped under main headings, which are arranged alphabetically. It should be noted carefully that these courses differ in their availability and a column has been provided to show, in the case of each course, what classification it falls into from this point of view. Classification adopted is as follows:—

- Courses open to all persons with a reasonable standard of primary education. These are marked in the following list with the word "Basic".
- Course open to all persons but which presuppose either that the student has completed some previous course under the Services Education Scheme or has reached a necessary standard of education as laid down in the R.A.N. Education Officers' Handbook. These are marked in the following list with the letter "P".
- Courses in the case of which an applicant must submit a sample of work so that a starting point can be determined. These are marked in the following list with the word "Sample".
- Courses available only to persons with definite trade qualifications. These are marked in the following list with the word "Closed".

Name of Subject.	Classification.	Approximate Price of Text-books.	State in which Available.
Agricultural Courses.—			
<i>Stage I., Agriculture</i>	Basic	Optional	N.S.W.
<i>Stage II., Agriculture</i>	Basic	Optional	
<i>Animal Husbandry</i>	Basic	..	
<i>Farm Machinery</i>	Basic	..	
<i>Farm Science</i>	Basic	..	
<i>Farm Arithmetic</i>	Basic	..	
N.B.—(No fee is charged for Farm Arithmetic if taken in conjunction with one of the two preceding subjects.)			
<i>Pig Raising</i>	Basic	..	W.A.
<i>Poultry Farming</i>	Basic	..	
<i>Sheep and Wool</i>	Closed	12 6	
<i>Station Bookkeeping</i>	Basic	..	
<i>Wool-classing</i>	P.	..	

Art Courses.—(N.B.—Applicants for these courses must forward a sample of work so that a starting point can be determined.)

<i>Design (General)</i>	Sample	..	N.S.W.
<i>Design (Abstract in Colour)</i>	Sample	..	
<i>Figure Drawing</i>	Sample	..	
<i>Freehand Drawing</i>	Sample	..	
<i>Lettering and Layout</i>	Sample	..	
<i>Object Drawing</i>	Sample	..	
<i>Rendering</i>	Sample	..	N.S.W., W.A.
<i>Sketching</i>	Sample	..	
<i>Short Display Card Writing</i>	*Basic	..	N.S.W.
<i>Ticket Writing</i>	*Basic	..	

* (The above courses conducted by the Architectural Department.)

<i>Commercial Art (Elementary)</i>	Basic	..	Vic., W.A.
<i>Commercial Art (L—W)</i>	Sample	..	Vic.
<i>Lettering</i>	Sample	..	Vic., W.A.
<i>Showcard and Ticket Writing</i>	Sample	..	Vic.
<i>Design (Elementary)</i>	Closed	..	Vic. (for teachers)
<i>Perspective</i>	Closed	..	
<i>Plant Form</i>	Closed	..	
<i>Geometric Drawing (Art)</i>	Closed	..	
<i>Blackboard Illustration</i>	Basic	..	
<i>Design and Colour</i>	Basic	Prices on request	
<i>Dimensioned Sketching</i>	Basic	Prices on request	S.A. (through School of Arts and Crafts)
<i>Freehand Drawing</i>	Basic	..	
<i>Geometrical Drawing</i>	Basic	Prices on request	
<i>Object Drawing (S.A.)</i>	Basic	..	Prices on request
<i>Perspective (S.A.)</i>	P.	..	
<i>Plant Drawing</i>	Basic	..	
<i>Lettering and Showcard Writing</i>	Basic	..	

Carpentry and Building Trade Courses.—(Subject in brackets, although to be treated as separate from the point of view of fee deposit, should be taken together, one stage to be taken at a time.)

BUILDING CONSTRUCTION COURSE.—

<i>Building Construction—</i>			
{ <i>Theory I., II., III.</i>	..	Closed	N.S.W.
{ <i>Drawing I., II., III.</i>	..	Closed	
{ <i>Calculations I., II., III.</i>	..	Closed	

Name of Subject.	Classification.	Approximate Price of Text-books. s. d.	State in which Available.
CARPENTRY AND JOINERY COURSE.—			
<i>Carpentry and Joinery—</i>			
{ <i>Theory I., II., III.</i>	..	Closed	N.S.W.
{ <i>Drawing I., II., III.</i>	..	Closed	
{ <i>Calculations I., II., III.</i>	..	Closed	
<i>Carpentry and Joinery—</i>			
<i>I., II., III., IV., V.</i>	..	Closed	W.A.
<i>Trade Work and Trade Drawing (Carpentry and Joinery)</i>	Closed	..	Qld.
<i>Builders' Quantities (Timber)</i>	..	P.	Vic., S.A. W.A.
<i>Builders' Quantities (Brick Buildings)</i>	P.	..	Vic.
<i>Concrete Engineering</i>	..	P.	Vic.
<i>Timber Measuring</i>	..	Basic	Vic.

Commercial and Clerical Courses—ACCOUNTANCY COURSES.—

<i>Bookkeeping</i>	Basic	4 6	N.S.W.
<i>Business Principles</i>	Basic	5 0	
<i>Commercial Correspondence</i>	Basic	..	
<i>Accountancy I. and II.</i>	P.	12 6	N.S.W.
<i>Auditing I.</i>	P.	29 6	
<i>Commercial Law I. and II.</i>	P.	12 6	
<i>Accountancy III. and IV.</i>	P.	16 6	
<i>Auditing II.</i>	P.	29 6	
<i>Commercial Law III. and IV.</i>	P.	12 6	
<i>Cost Accountancy</i>	..	P. 15 0	
<i>Bookkeeping (Preliminary and General)</i>	Basic	..	Vic., S.A., W.A.
<i>Commercial Correspondence</i>	Basic	6 6	Vic., S.A.
<i>Bookkeeping (Intermediate)</i>	P.	..	Optional
<i>Auditing (Intermediate)</i>	P.	..	
<i>Mercantile Law (Intermediate)</i>	P.	..	
<i>Bookkeeping (Final)</i>	P.	..	
<i>Auditing (Final)</i>	P.	..	
<i>Mercantile and Trustee Law</i>	P.	..	
<i>Company Law</i>	P.	..	Vic.
<i>Bankruptcy Law</i>	P.	..	
<i>Banking Finance and Foreign Exchange</i>	P.	..	

SECRETARIAL COURSES.—

<i>Handwriting</i>	Basic	..	Vic.
<i>Shorthand</i>	Basic	8 0	N.S.W., Vic.
<i>Typewriting</i>	Basic	7 6	N.S.W.
<i>Secretarial Knowledge and Duties</i>	P.	..	Vic.
<i>Company Formation and Administration</i>	P.	..	
<i>Legality and Conduct of Meetings</i>	P.	..	

BANKERS INSTITUTE COURSES.—

<i>Practical Banking (Intermediate)</i>	..	P.	Vic.
<i>Commercial Law (Intermediate)</i>	..	P.	
<i>Economics of Commerce (Intermediate)</i>	P.	..	
<i>Advanced Practical Banking and Securities</i>	P.	..	
<i>Banking Law (Final)</i>	..	P.	
<i>Commercial Law (Final)</i>	..	P.	

Name of Subject.	Classification.	Approximate Price of Text-books.	State in which Available.
LOCAL GOVERNMENT CLERKS COURSE (N.S.W.)—			
<i>Local Government—</i>			
<i>English</i>	P.	4 3	} N.S.W.
<i>Arithmetic</i>	P.	
<i>Bookkeeping</i>	P.	15 0	
<i>Accounts I.</i>	P.	
<i>Law I.</i>	P.	
<i>Accounts II.</i>	P.	
<i>Law II.</i>	P.	

Contributory Courses (Technical).—(The following subjects form part of the syllabus of instruction for Melbourne Technical College diploma and certificate courses in Mechanical, Civil, and Electrical Engineering, &c.)

MATHEMATICS—

Technical—

			<i>s. d.</i>	
<i>Grade I., Algebra</i>	P.	3 0	} Vic.
<i>Grade I., Trigonometry</i>	P.	13 6	
<i>Grade I., Geometry</i>	P.	8 1	
<i>Co-ordinate Geometry</i>	P.	8 11	
<i>Grade IIIA., Pure Mathematics</i>	P.	
<i>Grade IIB., Applied Mathematics</i>	P.	
<i>Grade IIC., Calculus</i>	P.	
<i>Advanced Mathematics for Chemistry Diploma</i>	P.	
<i>Technical Grade IIIA., Pure Mathematics</i>	P.	
<i>Technical Grade IIIB., Applied Mathematics</i>	P.	

PHYSICS—

<i>Grade IA., Physics (Mechanics and Heat)</i>	P.	} Vic.
<i>Grade IB., Physics (Sound and Light)</i>	P.	
<i>Grade IC., Physics (Electricity and Magnetism)</i>	P.	
(See also—Preparatory Courses.)				

APPLIED MECHANICS—

<i>Grade I., Applied Mechanics</i>	P.	} Vic.
<i>Grade II., Applied Mechanics (Strength of Materials)</i>	P.	
<i>Grade IIIA., Applied Mechanics (Structures)</i>	P.	
<i>Grade IIIB., Applied Mechanics (Machines)</i>	P.	
<i>Fluid Mechanics</i>	P.	

ENGINEERING DRAWING—

Engineering—

<i>Drawing I.</i>	P.	} 6 0	} Vic.
<i>Drawing IIA. (Structures)</i>	P.		
<i>Drawing IIB. (Machines)</i>	P.		
<i>Drawing IIIA. (Structures)</i>	P.		
<i>Drawing IIIB. (Machines)</i>	P.		

The following subjects form part of the syllabus of instruction for the Brisbane Technical College diplomas in mechanical and electrical engineering:—

Name of Subject.	Classification.	Approximate Price of Text-books.	State in which Available.
Diploma in Mechanical and Electrical Engineering—			
		<i>s. d.</i>	
<i>Algebra</i>	P.	} Qld.
<i>Geometry</i>	P.	
<i>Trigonometry</i>	P.	
<i>Mechanical Drawing I.</i>	P.	
(Other Subjects in Preparation.)			

Electrical Trade and Radio Courses.—

<i>Electrical Theory, Stage I.</i>	Closed	} N.S.W.
<i>Trade Calculations, Stage I.</i>	Closed	
<i>Applied Electricity (D.C.), Stages II. and III.</i>	Closed	
<i>Trade Calculations, Stages II., and III.</i>	Closed	
<i>Trade Drawing, Stages II. and III.</i>	Closed	
<i>Applied Electricity (A.C.), Stages IV. and V.</i>	Closed	
<i>Trade Calculations, Stages IV. and V.</i>	Closed	45 6	
<i>Wiring (Preliminary)</i>	P.	
<i>Wiring ("B" Grade)</i>	Closed	
<i>Wiring ("A" Grade)</i>	Closed	

<i>Preparatory Electrical Course</i>	Basic	} Vic.
<i>Illumination</i>	P.	
<i>Electrical Science for Radio Courses</i>	Basic	
<i>Radio Servicing, Maintenance and Repairs</i>	Closed	
<i>Radio Receiving</i>	Closed	

<i>Trade Drawing</i>	Closed	} Qld.
<i>Electrical Principles I.</i>	Closed	
<i>Trade Mathematics II.</i>	Closed	
<i>Trade Work I., II., and III.</i>	Closed	
<i>Electrical Principles II. and III.</i>	Closed	
<i>Applied Electricity I., II., III., and IV.</i>	Closed	
<i>Radio Communications I. and II.</i>	Closed	

Engineering Trade and Allied Courses.—

<i>Diesel Engine Operation</i>	P.	9 0	} N.S.W.
<i>Engineering Trades Drawing I., II., and III.</i>	Basic	
<i>Fitting and Machining—</i>			
<i>Theory I., II., and III.</i>	Closed	
<i>Calculations I., II., and III.</i>	Closed	18 0	
<i>Drawing I., II., and III.</i>	Basic	
<i>Motor Maintenance</i>	Basic	

Name of Subject.	Classification.	Approximate Price of Text-books.	State in which Available.	
Motor Mechanics—				
<i>Theory</i>	Closed	} N.S.W.	
<i>Drawing</i>	Closed	16 6		
<i>Calculations</i>	Closed		
<i>Suction (Producer) Gas Engine Driving</i> ..	Basic		
<i>Steam Engine Driving and Boiler Attendants</i>	Basic		
Basic Workshop Theory Basic				
<i>Boiler Attendance</i>	Closed	} Vic.	
Engine-driving—				
<i>(Second-class)</i>	Closed		
<i>(First-class)</i>	Closed		
<i>(Second-class Mining)</i>	Closed	} Vic.	
<i>(First-class Mining)</i>	Closed		
<i>Refrigeration, Electric</i>	P.	Vic.	
Air Conditioning (General) Closed				
<i>Electric Welding</i>	Closed	} W.A.	
<i>Internal Combustion Engines</i>	P.		
FITTING AND TURNING COURSE (Brisbane).				
<i>Trade Work I., II., and III.</i>	Closed	} Qld.	
<i>Trade Drawing</i>	Closed		
<i>General Science</i>	Closed		
<i>Trade Mathematics I. and II.</i>	Closed		
<i>Mechanical Drawing I. and II.</i>	Closed		
<i>Engineering Chemistry</i>	Closed		
<i>Elementary Heat Engines</i>	Closed		
<i>Oxy Welding</i>	Closed		
MOTOR MECHANICS COURSE (Brisbane).—				
<i>Trade Work, Trade Drawing, General Science, Trade Mathematics and Engineering Chemistry as above and—</i>			}	
<i>Mechanical Drawing I...</i>	Closed		
<i>Car Electrics I. and II.</i>	Closed		
Mining Courses.—				
<i>Mining I.</i>	P.	} W.A.	
<i>Mining II.</i>	P.		
<i>Metallurgy I.</i>	P.		
<i>Ore Dressing I.</i>	P.		
<i>Assaying I.</i>	*P.		

* (Applicants will not be enrolled for this subject unless they have access to an assay laboratory.)

Name of Subject.	Classification.	Approximate Price of Text-books.	State in which Available.
Miscellaneous Courses.—			
<i>s. d.</i>			
<i>Breadbaking</i>	Closed	Vic.
<i>Foremanship</i>	P.	Vic.
<i>Salesmanship</i>	Basic	Vic., W.A.
<i>Road Board and Municipal Officer's Course</i>	Closed	W.A.
<i>Elementary Japanese</i>	P.	Vic.
Printing Trade Courses.—			
<i>Composing Stages I., II., and III.</i>	Closed	} N.S.W.
<i>Printers' English and Arithmetic</i>	Closed	
<i>Linotype Operation</i>	Closed	Prices on request	
<i>Composing Grade I.</i>	Closed	} Vic.
<i>Composing Grade II.</i>	Closed	
<i>Printing Trade English</i>	P.	1 0	
<i>Printing Trade Mathematics</i>	Closed	
<i>Printing Trade Drawing</i>	Closed	} W.A.
<i>Printing Machinery Stages I., II., III., IV., and V.</i>	Closed	
<i>Printing Composing Stages I., II., III., IV. and V.</i>	Closed	
Public Health Courses.—			
HEALTH INSPECTION COURSE—			
<i>Elementary Public Health Science</i>	P.	8 3	}
<i>History and Survey of Local Government (for further subjects see "Handbook")</i>	P.	
MEAT INSPECTION COURSE—			
<i>Practical Sanitation</i>	P.	32 6	} N.S.W.
<i>Meat Inspection</i>	P.	25 0	
COUNTRY TOWN DRAINERS' AND WATER PLUMBERS' COURSE—			
<i>House Drainage</i>	*	32 6	}
<i>Water Plumbing</i>	*	
COUNTRY TOWN SEWER PLUMBING COURSE—			
<i>Sewer Plumbing Stages I. and II.</i>	*	39 0	}
* Subjects in the above two courses are not "closed", but are not recommended to persons who have not had practical experience.			
Surveyors' Courses.—			
<i>Land Surveying, I., II. and III.</i>	P.	} Vic.
<i>Laws and Regulations for Surveyors</i>	P.	
<i>Forestry</i>	P.	
<i>Geology I.</i>	P.	

Name of Subject.	Classification.	Approximate Price of Text-books.	State in which Available.
Women's Home and Handicraft Courses.—			
		<i>s. d.</i>	
<i>Dressmaking I. (Designing, Cutting and making)</i>	Basic	14 6	} N.S.W.
<i>Dressmaking II. (Designing, cutting and making)</i>	Basic	
<i>Millinery</i>	Basic	
<i>Dressmakers' and Milliners' Art Stage I. (Freehand Drawing)</i>	Basic	
<i>Dressmakers' and Milliners' Art Stage II. (Drapery Drawing)</i>	P.	
<i>Dressmakers' and Milliners' Art Stage III. (Drapery Drawing)</i>	P.	
<i>Home Management</i>	Basic	Vic., S.A., W.A.

X-Ray Courses.—

<i>Anatomy and Physiology</i>	P.	} Vic.
<i>Physics I. and II.</i>	Closed	19 0	
<i>Chemistry</i>	Closed	19 3	
<i>Positioning</i>	Closed	

SECTION III.

Some subjects which form part of the prescribed course of study for the degrees of Bachelor of Arts, Bachelor of Economics or Commerce, and Bachelor of Laws are available through the following Universities. *At present no fee deposit is required in respect of these subjects.*

University of Sydney.
University of Melbourne.
University of Queensland.
University of Adelaide.
University of Western Australia.
University of Tasmania.

Students who wish to study for the degree of Bachelor of Science may take Mathematics.

Subjects are available for diploma courses as follows:—

(i) University of Melbourne—

Diploma of—
Commerce.
Education.
Journalism.
Public Administration.
Social Studies.
Physical Education.

(ii) University of Sydney—

Diploma of—
Public Administration.
Education.
Social Studies.

(iii) University of Queensland—

Diploma of—
Education.
Music.
Journalism.

Also Certificate Courses in *Education* and *Accountancy.*

(iv) University of Adelaide—

Diploma of—
Commerce.
Public Administration.
Education.
Social Science.

(v) University of Tasmania—

Diploma of—
Commerce.
Public Administration.

Applications for enrolment in subjects for the above courses should be lodged before the end of February, 1945. Details of subjects available will be contained in a further section of the Handbook for Education Officers which will be distributed in due course. In the meantime, intending students should forward a General Information Form so that they can be advised on their eligibility and a suitable choice of subjects.

Courses for Teachers.—Correspondence instruction is available to personnel who, at the time of enlistment, were students of the Sydney or Armidale Teachers' Colleges or who had been accepted for admission to one of the above colleges.

Correspondence instruction is available through the Department of Public Instruction, Brisbane, in all the subjects required for the Departmental Examination for admission as Teacher of Class II. and III. Enrolment is not restricted to teachers.

The following courses are now available from the Victorian College of Pharmacy. Students who desire to enrol should forward a General Information Form so that they may be advised of their eligibility and fees payable.

Name of Subject.	Classification.
<i>Introductory Course (V.C.P.)</i>	.. P.
<i>First Year Course (V.C.P.)</i>	.. Closed
<i>Second Year Course (V.C.P.)</i>	.. Closed

Details of courses through the Marconi School of Wireless, the British Institute of Engineering Technology, the Victorian Postal Institute, the N.S.W. Postal Institute, the Victorian Railways Institute, the N.S.W. Railways Institute and other bodies will be promulgated as soon as they are made available.

(840/201/2.)

(This Order will be reprinted for posting on Notice Boards.)

RESTRICTED.(FOR OFFICIAL USE ONLY.)

Commonwealth Navy Orders.

Navy Office, Melbourne,
10th October, 1944.

The following Orders, having been approved, are hereby promulgated for information and guidance, and necessary action.

By direction of the Naval Board,

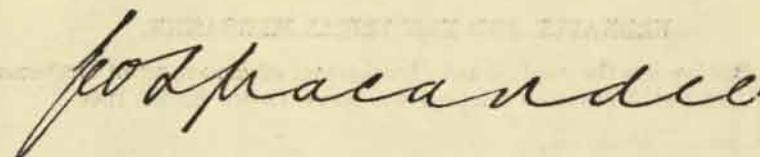

Secretary.

*The Commodore Commanding H.M.A. Squadron,
and Commanding Officers of H.M.A. Ships,
Officers in Charge of H.M.A. Naval
Establishments, and others concerned.*

TABLE OF CONTENTS.

No.	Subject.
525.	Transport of Mails in H.M.A. Ships.
526.	Ordnance and Electrical Mechanics.
527.	Medical Officers' Journals.
528.	Prevention of Fire—Petrol Engined Craft.
529.	Gun Trial Reports—Elevating and Training Efforts.
530.	Guns—20 m.m. Oerlikon—Spares, Appurtenances, &c.—Basic Sets.
531.	Inspection of Rifles.
532.	Pistols M.Ls. 9.5-in. Depth Charge Thrower Mk. II—Use of Correct Description.
533.	Care of Stores When Ships are Undergoing Repair, &c.
534.	India Rubber Washers for Hose Couplings—Use of Correct Patterns.
535.	Stretcher Cots—Pattern 474—Supply.
536.	Boots, Football—Amended Issuing Price.
537.	Flags—Precautions to be Taken in Washing.
538.	Supply of Liquor to H.M.A. Ships and Establishments by the Australian Army Canteens Service.
539.	Form A.M.2Z—Health—Prevention of Disease and Maintenance of Health in Tropical Climates.

525.

TRANSPORT OF MAILS IN H.M.A. SHIPS.

When bags of mail are placed on board H.M.A. Ships for carriage to another port, the Commanding Officer is to ensure that a schedule (in duplicate) setting out the number of bags, and indicating the addresses to which they are to be delivered, accompanies the shipment.

2. Receipt for the bags is to be given on one copy of the schedule. The second copy is to be retained in the ship and signatures obtained thereon when the bags are delivered to the addressees or handed over for onward transmission.

3. C.O.R., Article 329, will be amended in due course.

(563/201/1444)

526.

ORDNANCE AND ELECTRICAL MECHANICS.

Following are the conditions of service and advancement of Ordnance and Electrical Mechanics adopted by Navy Order 82 of 1944.

2. Ordnance Mechanic.

- (i) Rating is open to Able Seamen (Q.O.) only. Selected ratings must have had sea-going experience in the non-substantive rating of Q.O.
- (ii) On selection ratings will be drafted for a 16 weeks' course at Melbourne Technical College in fitting and turning.
- (iii) On satisfactory completion of the course, rating will be transferred to the rating of Ordnance Mechanic, 5th Class, by the Naval Officer-in-Charge, Flinders Naval Depot.

3. Electrical Mechanic.

- (i) Open to Wiremen (L) and Leading Wiremen (L) who have completed 12 months' sea service as Wiremen and have shown an aptitude for mechanical work.
- (ii) Selected ratings will be given a 16 weeks' course in fitting and turning at a Technical School, on successful completion of which they will be given a modified E.A. Course, at R.A.N. Torpedo School. On satisfactory completion of this course, they will be transferred to Electrical Mechanic, 5th Class, by the Naval Officer-in-Charge, Flinders Naval Depot.

4. Advancement.

- (i) Ordnance and Electrical Mechanics will be advanced to a higher class by the Commanding Officer under the following conditions:—

*5th Class (Relative rating Ldg. Smn.) to
Acting 4th Class (Relative rating P.O.)*

- (a) One year as 5th Class.
- (b) Over 21 years of age.
- (c) Recommended for advancement by technical officer.

- (ii) Ratings will be confirmed as 4th Class on completion of 12 months' satisfactory service in the acting rate.

4th Class to 3rd Class.

3 years as 4th Class and recommended for advancement.

3rd Class to 2nd Class.

7 years as 4th Class and above.

2nd Class to 1st Class.

(a) 12 years as 4th Class and above.

(b) Relative rating of 3rd Class and above to be that of C.P.O.

5. Uniform.

- (i) On transfer, to be Class III without any distinguishing badge.
- (ii) On confirmation as 4th Class, the uniform of a Petty Officer over 1 year.
- (iii) On advancement to 3rd Class, Class I uniform to be worn.

(349/3/167)

(This Order will be reprinted for posting on Notice Boards.)

527.

MEDICAL OFFICERS' JOURNALS.

The Medical Officer-in-Charge of each H.M.A. Ship and Naval Establishment is to keep a rough and fair Journal (A.M. 179) of his practice, including therein all cases treated on the Sick List in the ship or establishment under the care of any Medical Officer.

2. The Journal is to be made up quarterly to 31st March, 30th June, 30th September and 31st December of each year, or to the date of cessation of medical charge, unless approval has been granted by Director of Naval Medical Services to vary the practice owing to special circumstances.

3. In vessels where a member of the Sick Berth Staff is borne but no Medical Officer, the Commanding Officer is to act in lieu of the Medical Officer by signing and initialling the parts of the Journal as necessary.

4. A complete set of R.A.N. Medical Journal Instructions accompanies each set of Journal parts as a first issue and should be studied carefully by all concerned.

5. The fair copy of the Medical Journal is to be kept in such a state of preparation that at any time it may be transmitted to the Director of Naval Medical Services, and it is, at the latest, to be transmitted within ten days after the termination of the period for which it is made up, except returns from depots with large and varying complements, in which case 30 days will be allowed for rendition of the Journal.

6. The Journal is to be forwarded by registered mail and the container is to be conspicuously marked "To be opened only by Director of Naval Medical Services." A separate communication is to be sent advising date of despatch of the Journal.

7. Any delay in forwarding the Journal is to be explained fully, by letter, to the Director of Naval Medical Services through the Commanding Officer.

8. Table I, Part 3, A.M. 179, "Movements of the Vessel," is not to be rendered by ships during hostilities.

9. Prior to despatch, Parts 3, 4, 5, 7 and 8 of the Journal are to be sent to the Commanding Officer for his information, and Part 8 is to be signed by him before the complete Journal is forwarded to the Director of Naval Medical Services.

10. This Order will be included in R.I. Series in due course.

11. Navy Orders 159 of 1930, 85 of 1933, and 50 and 176 of 1937 are hereby cancelled.

(527/210/4077.)

528.

PREVENTION OF FIRE—PETROL ENGINED CRAFT.

Admiralty Fleet Orders 865 and 866 of 1944 have been reprinted and distribution of two copies of each to Fairmiles and H.D.M. Ls. is being effected by the Superintending Naval Store Officer, Sydney.

2. Commanding Officers of small craft concerned are to arrange for one copy of each of these A.F.Os. to be pasted in an appropriate place in the M.L. Instruction Book for reference in conjunction therewith, the other copy of each being pasted on a board and exhibited in a prominent position in the vessel for guidance of all personnel.

(546/202/565.)

529.

GUN TRIAL REPORTS—ELEVATING AND TRAINING EFFORTS.

Gun trial reports recently received at Navy Office indicate considerable variation in the procedure for measuring elevation and training efforts. The following standardized procedure is to be used on all future occasions:—

I. *Elevation Efforts.*

(a) The gun should be in the same state as it would be while the gunlayer is laying in action. In the case of mountings fitted with loading trays, elevating and depressing efforts should be taken—

- (i) with guns and trays loaded,
- (ii) with guns loaded, tray unloaded.

Example (A)—4.7-in. twin Mark XIX mounting.

- Both (a) Both guns loaded, both loading trays loaded;
- and (b) Both guns loaded, both trays unloaded.

Example (B)—40 m.m. Bofors Mark IIIA mounting.

- One round on the loading tray, five rounds in the auto-loader.

(b) Efforts are to be measured at all elevations. If the efforts are uniform over the full limits, only the average figure need be reported, but if there is any appreciable variation at different elevations, the maximum and minimum efforts for elevation and depression are to be reported together with the elevations at which they occur.

II. *Training Efforts.*

(a) Efforts are to be measured as in I (a) above, with the addition that all members of the gun's crew who are carried on the mounting should be closed up, and any ready-use ammunition normally carried on the mounting should be in position.

(b) Efforts are to be measured on all bearings where the mounting can fire. If the efforts are uniform over the full limits, only the average figure need be reported, but if there is any appreciable variation on different bearings, the maximum and minimum efforts right and left are to be reported, together with the bearings on which they occur.

(490/201/1960.)

530.

GUNS—20 M.M. OERLIKON—SPARES, APPURTENANCES, ETC.— BASIC SETS.

The provisions of Admiralty Fleet Orders 2603/44 and 2604/44 are to apply in the Royal Australian Navy.

2. Supply of labels is being arranged by the Superintending Armament Supply Office, Sydney, to whom demands for requirements should be forwarded.

(490/212/1144.)

531.

INSPECTION OF RIFLES.

A number of rifles has been issued to Naval Establishments and advanced bases in boxes and cartons. These are to be unpacked as soon as possible after receipt and all rifles showing signs of rust or mildew are to be stripped and cleaned.

2. All small arms are to be frequently inspected and liberally coated with mineral grease to prevent deterioration.

(412/202/403.)

532.

PISTOLS M.L. 9.5-IN. DEPTH CHARGE THROWER MK. II—USE OF CORRECT DESCRIPTION.

Pistols for Depth Charge Throwers are always to be accounted for and described as follows:—

Pistols, M.L. 9.5-in. D.C.T., Mk. II.

2. Some boxes containing these pistols received from manufacture have been incorrectly marked "Strikers Mark II." This marking is to be obliterated on the boxes concerned, which are to be re-marked in accordance with paragraph 1.

(471/205/2267.)

533.

CARE OF STORES WHEN SHIPS ARE UNDERGOING REPAIR, ETC.

The special attention of all Commanding Officers and other responsible officers concerned is drawn to A.F.O. 809/44, regarding the care of stores of all descriptions, when ships are under repair while in commission with stores on board or refitting, &c.

2. The instructions in that Order are to be closely observed generally in the case of H.M.A. Ships, and Commanding Officers are to ensure that its provisions are brought to the notice of responsible officers and others concerned on all occasions immediately before the vessel is placed in dockyard hands.

(612/201/5571.)

534.

INDIA RUBBER WASHERS FOR HOSE COUPLINGS—USE OF CORRECT PATTERNS.

With reference to Navy Orders 144 and 209 of 1943, demands are still being received from H.M.A. Ships and Establishments for Patterns 1200 and 1200A Series India Rubber Washers for Standard Admiralty Pattern Couplings, instead of the correct patterns, i.e., 1220 Series.

2. The washers used with the respective couplings are shown in the above-mentioned Navy Orders, and action is to be taken to ensure that the correct patterns are demanded in future.

(612/229/178.)

535.

STRETCHER COTS—PATTERN 474—SUPPLY.

With reference to A.F.O. 2803/42 and Navy Order 243 of 1944, no demands have been received from ships in commission for Pattern 474 Stretcher Cots.

2. Demands for requirements should be forwarded to the Superintending Naval Store Officer, Sydney, as early as practicable.

(612/235/917.)

536.

BOOTS. FOOTBALL—AMENDED ISSUING PRICE.

The price of Boots, Football, shown on page 3 of the "Official Memorandum—Prices of Clothing, &c., maintained for issue on repayment to Ships' Companies" dated 1st May, 1944, is to be altered from 8s. 5d. to 12s. per pair.

2. The increased price is to operate from the date of issue of this Navy Order.

(420/201/1004.)

537.

FLAGS—PRECAUTIONS TO BE TAKEN IN WASHING.

Attention is drawn to A.F.O. 6154/43 in regard to the correct method of washing flags.

(476/201/752.)

538.

SUPPLY OF LIQUOR TO H.M.A. SHIPS AND ESTABLISHMENTS BY AUSTRALIAN ARMY CANTEENS SERVICE.

Arrangements have been made with the Australian Army Canteens Service for the supply of liquor, on a weekly basis, to H.M.A. Ships and Establishments as follows:—

(a) *Officers' Messes.*—If requested, Australian Army Canteens Service will make supplies available to officers' messes (ashore and afloat) which elect to draw supplies regularly from that source, such issues being confined to the ration scale applying to Army messes in the area in which the Australian Army Canteens Service issuing depot is situated.

(b) *Petty Officers and Men.*—Australian Army Canteens Service has undertaken, if advised of the numbers involved, to make available in advanced areas supplies of beer to Commanding Officers for consumption by petty officers and men. Such supplies will similarly be confined to the approved scale for Army personnel in the area of supply. Naval Canteens conducted by Australian Army Canteens Service will, however, be supplied direct by that Service as hitherto.

2. It is important, in remote or advanced areas, that the Officer-in-Charge of the Australian Army Canteens Service for the area is given, through the Naval Officer-in-Charge, as much notice of requirements as possible in order to enable the necessary desired provision to be made. If this is not done, Australian Army Canteens Service cannot guarantee supplies being available.

3. In regard to paragraph 2 above, if a ship has been absent from the port for more than a week, supply for the period of the absence may be drawn, if available, on the certificate of the Commanding Officer that supplies for the period, or any part of the period, have not been drawn in any other area or obtained from any other source. Not more than two bottles of beer are, however, to be issued to a rating on any one day.

4. Requisitions for supplies generally are to be supervised closely by Commanding Officers in order that equitable distribution of available stocks may be ensured by the avoidance of the possibility of total receipts from all sources being in excess of the approved ration for the area.

(668/202/235.)

539.

**FORM A.M. 2Z.—HEALTH—PREVENTION OF DISEASE AND
MAINTENANCE OF HEALTH IN TROPICAL CLIMATES.**

Form A.M. 2z. is being printed in booklet form and will be issued without demand to Officers-in-Charge of Naval Tropical Stations and R.A.N. Ships working in tropical areas.

2. Commanding Officers of H.M.A.S. *Moreton*, *Rushcutter*, and *Penguin*, also the R.A.N. Accountant Officer, Colombo, will receive stocks of the Form for personal issue only to members of the R.A.N. proceeding through these points for service indicated in paragraph 1 above.

3. A small stock of spares will be held by the Medical Store Officer, Sydney, to whom demands for replenishment should be forwarded.

4. Steps are to be taken to ensure that each member of the R.A.N. serving in tropical areas has a personal copy of the booklet.

(527/211/2069.)

RESTRICTED.(FOR OFFICIAL USE ONLY.)

Commonwealth Navy Orders.

Navy Office, Melbourne,

17th October, 1944.

The following Orders, having been approved, are hereby promulgated for information and guidance, and necessary action.

By direction of the Naval Board,

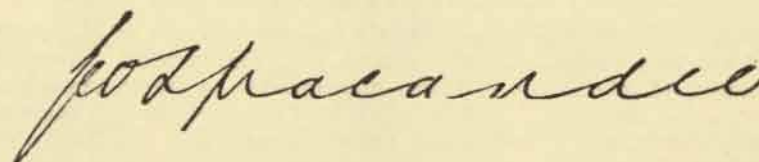

Secretary.

*The Commodore Commanding H.M.A. Squadron,
and Commanding Officers of H.M.A. Ships,
Officers in Charge of H.M.A. Naval
Establishments, and others concerned.*

TABLE OF CONTENTS

No.	Subject.
540.	Port Directors.
541.	Naval Board of Administration.
542.	Maintenance Bases on Shore and Repair Ships—Distribution of Personnel.
543.	Radar Control and Radar Plot Ratings—Detailed Arrangements—Reports.
544.	Australian Red Cross Society.
545.	A.M.S. Vessels—L.L. Cable Drums—Stiffening of Hand Winding Gear.
546.	Range Transmitter from Radar to Transmitting Station—Alteration and Addition.
547.	Misalignment of Shafting in M.L's.
548.	Gun Mountings—40 m.m. Bofors—Foresights.
549.	Anti-Gas Eyeshields—Protection.
550.	Injuries and Wounds by Enemy Action.
551.	Naval Salvage Money—Distribution.
552.	Issue of Mess Gear and Blankets to Personnel Travelling.
553.	Sugar—Consumption Outside Territorial Waters.
554.	Books and Forms.

540.

PORT DIRECTORS.

With reference to Navy Order 425 of 1944, the Port Directorate at Saidor has now been closed.

(1804/2/88.)

541.

NAVAL BOARD OF ADMINISTRATION.

Captain Henry Arthur Showers, R.A.N., has been appointed Second Naval Member of the Naval Board of Administration with the rank of Commodore Second Class, as from 15th October, 1944, in place of Rear Admiral (Acting) George Dunbar Moore, C.B.E., who has been appointed Naval Officer-in-Charge, Sydney.

(404/201/682.)

542.

**MAINTENANCE BASES ON SHORE AND REPAIR SHIPS—
DISTRIBUTION OF PERSONNEL.**

In order to facilitate the repair and maintenance of H.M.A. Ships, it has been decided that the artisan staff (shipwrights, joiners, blacksmiths, plumbers and painters) appropriated to maintenance bases on shore and to repair ships for duty other than depot or ship maintenance respectively, are to be brought under the control of the Base Engineer Officer.

2. Ordnance and electrical artificers and wiremen borne for base repair staff similarly are to be under control of the Base Engineer Officer, except where a Port Gunnery and/or Torpedo Officer is borne.

3. In future, the Naval Officer-in-Charge, Flinders Naval Depot, will indicate on draft notes whether ratings mentioned in paragraphs 1 and 2 are for base repair staff or depot maintenance or, in case of repair ships, for repair staff or ship maintenance.

4. In carrying out these instructions, due regard is to be had to K.R. and A.I., Article 1506.

5. Nothing in this Order is to be interpreted as altering the existing division of responsibility in the control of artisan ratings in H.M.A. Ships (other than those specifically designated as repair ships).

(463/205/5810.)

543.

**RADAR CONTROL AND RADAR PLOT RATINGS—DETAILED
ARRANGEMENTS—REPORTS.**

With reference to A.F.Os. 5195/43 and 797/44, the following are detailed instructions for the institution of Radar Control and Radar Plot Ratings in the R.A.N.

2. The various grades of non-substantive Radar Control and Radar Plot ratings, rates of pay and qualifications necessary for advancement, are laid down in Appendices "A" and "B" to this Order. The titles and duties of Radar Control Instructor and Radar Plot Instructor ratings are still under consideration; further instructions will be promulgated later.

3. The new rates of pay have been adopted on and from 15th May, 1944. In order to absorb existing Radar ratings into the new branches, certain transitional substantive and non-substantive ratings are created on a provisional basis, details of which are given in paragraph 4 below. In no case will ratings suffer any decrease in their pay pending confirmation.

4. Existing Radar ratings will be absorbed into the new organization in the corresponding Seaman ratings, provided that they are medically and visually fit for Seaman Branch, and have acquired the appropriate qualification in seamanship. Men who have defective colour vision and wear glasses are eligible for transfer provided that their vision is not below Standard 3. Changes in ratings will take place as follows:—

- (i) The initial transfer of ratings into their categories will be made from rosters established at H.M.A. Radar School as a result of Navycirc message 5471.

In general, those Radar ratings experienced in gunnery sets will become Radar Control ratings and those qualified in W.A. or W.S. sets will become Radar Plot ratings. Commodore Superintendent of Training will inform ships as soon as possible to which category ratings have been transferred.

Present serving Able and Ordinary Seamen (Radar) will be granted the non-substantive rating of R.P.3 or R.C.3, Leading Seaman (Radar) to that of R.P.2 or R.C.2 in manner described below.

- (ii) Ratings will retain their Radar status until they have qualified professionally in seamanship. On passing in seamanship, they will cease to be designated "Radar" ratings. Until qualified in Fire Control or Plotting, the suffix (P)—Provisional—will be added to the indication of Branch. They will be paid as shown in Appendix "C". Since qualification in seamanship may either precede or follow qualification for the non-substantive rating, transfer can take place in alternative ways, as illustrated by the following examples:—

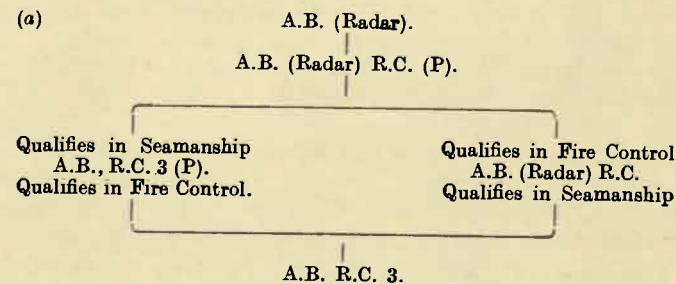

Able Seaman (Radar) transferring to R.P.3 will follow this procedure except that in place of Fire Control, they must qualify in Plotting.

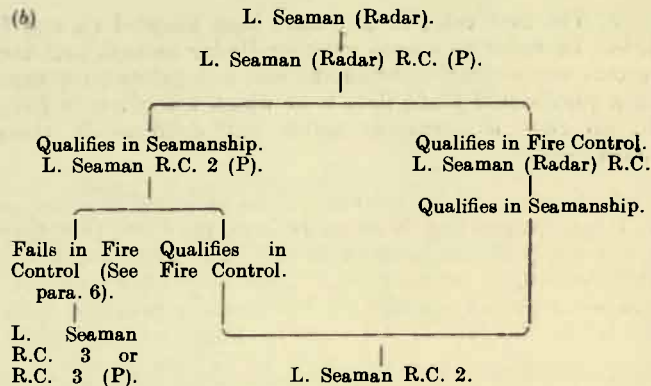

- (iii) Able Seaman (Radar) recommended for Leading Seaman (Radar), and Leading Seaman (Radar) recommended for Petty Officer (Radar), whose names appear on the rosters for their respective courses under Navy Order 519 of 1943 at the time this Order comes into force will not be required to requalify in their present rates under (i) and (ii) above. These recommendations will be considered as recommendations for the appropriate second class or first class non-substantive rates respectively and ratings will be drafted for these courses as soon as possible. Upon qualifying, ratings will be advanced to Leading Seaman and Petty Officer and back dated to the date of first recommendation remaining Leading Seaman (Radar) R.C. or R.P. or Petty Officer (Radar) R.C. or R.P. until qualified in seamanship as shown in (ii) above.

5. *Inability to Qualify in Seamanship.*—(i) The individual cases of Radar ratings who fail to qualify in seamanship or who are found medically or visually unfit for the Seaman Branch are to be referred to the Naval Board for decision.

(ii) Radar ratings who fail to qualify in seamanship are to be employed on ship's duties when not employed on Radar duties. Every endeavour is to be made to bring them up to the required standard by employing them on work which will widen their knowledge and develop their powers of leadership.

6. *Inability to Qualify in Radar, Fire Control or Plotting.*—Seaman ratings holding a provisional rating who fail to qualify in their courses in Fire Control or Plotting will revert to the next lower non-substantive rating from the date of failure. This rating may be confirmed or provisional at the discretion of the Commodore Superintendent of Training. Failure to qualify for third class rating entails remaining as R.C.3(P) or R.P.3(P), the names of such ratings being reported to the Naval Board. Ratings who fail to qualify may not be recommended again for course until twelve months after the date of failure.

7. *Selection and Training.*—(i) The standards of knowledge required by R.C. and R.P. ratings, and the duties they will carry out at sea are laid down in Appendix "E" to A.F.O. 797/44; the authorities empowered to grant non-substantive ratings and the qualifications required for examining officers are as stated in Appendices "A" and "B".

(ii) In the early stages, R.C.1's. qualified from Petty Officer Radar are unlikely to achieve the full standard of gunnery knowledge laid down in Appendix "E" of A.F.O. 797/44 due to their lack of previous experience and may be required to carry out a requalifying course in gunnery to bring them up to the full standard after at least one year's experience as R.C.1 or Petty Officer (Radar) (R.C.).

8. New entry ratings who are selected for Radar Control will undergo a Radar course in H.M.A. Radar School and a Fire Control course in a Gunnery School before being drafted to sea. New entry ratings selected for Radar Plotting will undergo both Radar and Plotting courses in H.M.A. Radar School. On completion of courses, successful candidates will be rated A/R.C.3 or A/R.P.3. R.P.3 ratings will be given additional training in Radar Training vessel.

9. Present Radar ratings serving at sea will, in general, undergo qualifying courses in Fire Control or Plotting for R.C.3 or R.P.3 in their own ships. In cases where, for any reason, such courses cannot be given on board, administrative authorities should arrange for ratings to be sent to the nearest Gunnery School or H.M.A. Radar School.

10. (i) Commodore Superintendent of Training and H.M.A. Radar School will require reports of recommendations for course for R.C. or R.P. ratings. Such recommendations are to be rendered on form S.1303 on the 1st of each quarter and at any particularly suitable time (e.g. commencement of refit) to these authorities. It is pointed out that such recommendations can be forwarded at any time.

(ii) It is also important that ships training third class R.C. or R.P. ratings at sea should report to Commodore Superintendent of Training and H.M.A. Radar School details and results of examinations carried out in accordance with paragraph 9 above.

(iii) Ratings, whose names appear on the roster for advancement to Leading Seaman (Radar) on or before the date of issue of this Navy Order, will be drafted by the Naval Officer-in-Charge, Flinders Naval Depot, to H.M.A. Radar School for a qualifying course for R.P./R.C.2. On completion, results are to be forwarded to the Naval Officer-in-Charge, Flinders Naval Depot, who will make advancements, for those who qualify, to Leading Seaman to fill vacancies in Fleet Numbers, antedating seniority to the date of first recommendation for Leading Seaman (Radar). Ratings not qualified in seamanship will be granted provisional rating as in paragraph 4 until qualified.

11. *Badges.*—Instructions regarding badges for Radar Control and Radar Plot ratings will be issued shortly.

12. Navy Orders 519 of 1943, 84 and 249 of 1944 are hereby cancelled.

RADAR CONTROL RATINGS—RATES OF NON-SUBSTANTIVE PAY AND QUALIFICATIONS REQUIRED FOR SELECTION FOR COURSES.

543

Non-Substantive Rating.	Open to.	Special Qualifications.	Where Course Carried Out.	Authority to give Rating.	Examining Officers.	Rate per Diem.	Remarks.
R.C. 1. (Radar Control rating 1st Class)	C.P.O., P.O., and Ldg. Sea. R.C. 2	(a) Recommended by C.O. (b) One year's service as R.C. 2 ashore or afloat (see note) (c) A total of 1 year's service as R.C. 3 and/or R.C. 2 must have been served afloat (see note)	(a) Radar School (b) Gunnery School, F.N.D.	C.S.T. on completion of both courses	Officers of Radar and Gunnery Schools	1s. 6d.	Not payable with any other non-substantive rating except Diver
R.C. 2. (Radar Control rating 2nd Class)	Ldg. Sea. and A.B. R.C. 3, C.P.O. and P.O. ex R.C. 3	(a) Recommended by C.O. (b) Six months' service as R.C. 3 afloat or ashore (see note). Service ashore will only count as qualifying time during the period of the present hostilities	(a) Radar School (b) Gunnery School, F.N.D.	C.S.T. on completion of both courses	Officers of Radar and Gunnery Schools	P.O's., 6d.; Ldg. Sea. or A.B., 9d.	Not payable with any other non-substantive rating except Diver
R.C. 3. (Radar Control rating 3rd Class)	Ldg. Sea., A.B., or Ord. Sea.	Recommended by C.O.	(a) In Radar and "G" Schools. (b) Present Radar Ratings at sea (see para. 9)	C.S.T.	Qualified Radar and Gunnery Officers at sea, or Officers of Radar and Gunnery Schools	3d.	Not payable with any other non-substantive rating except Diver or Physical and Recreational Training Instructor. Ordinary Seaman can only hold the acting rating of R.C. 3 and will only be paid when actually filling a vacancy in complement

NOTE.—Time as R.C. 3 (P) or A.B. (Radar) counts as service as R.C. 3.
Time as R.C. 2 (P) or L.S. (Radar) counts as service as R.C. 2.

6

RADAR PLOT RATINGS—RATES OF NON-SUBSTANTIVE PAY AND QUALIFICATIONS REQUIRED FOR SELECTION FOR COURSES.

Non-Substantive Rating.	Open to.	Special Qualifications.	Where Course Carried Out.	Authority to give Rating.	Examining Officers.	Rate per Diem.	Remarks.
R.P. 1. (Radar Plot Rating, 1st Class)	C.P.O., P.O., and Ldg. Sea. R.P. 2	(a) Recommended by C.O. (b) One year's service as R.P. 2 ashore or afloat (see note). (c) A total of one year's service as R.P. 3 and/or R.P. 2 must have been served afloat (see note)	Radar School ..	H.M.A. Radar School on completion of both courses	Officers of Radar School	1s. 6d.	Not payable with any other non-substantive rating except Diver
R.P. 2. (Radar Plot Rating 2nd Class)	C.P.O. and P.O. ex R.P. 3, Ldg. Sea. and A.B. R.P. 3	(a) Recommended by C.O. (b) Six months' service as R.P. 3 afloat or ashore (see note). Service ashore will only count as qualifying time during the period of the present hostilities	Radar School ..	H.M.A. Radar School on completion of both courses	Officers of Radar School	P.O's., 6d.; Ldg. Sea. or A.B., 9d.	Not payable with any other non-substantive rating except Diver
R.P. 3. (Radar Plot Rating, 3rd Class)	Ldg. Sea., A.B., Ord. Sea.	Recommended by C.O.	At sea or in Radar School	H.M.A. Radar School	Qualified Radar and Fighter Direction or Navigation. Officers at sea or Officers of Radar School	3d.	Not payable with any other non-substantive rating except Diver or Physical and Recreational Training instructor. Ordinary seamen can only hold the acting rating of R.P. 3, and will only be paid when actually filling a vacancy in complement

NOTE.—Time as R.P. 3 (P) or A.B. (Radar) counts as service as R.P. 3.
Time as R.P. 2 (P) or L.S. (Radar) counts as service as R.P. 2.

7

543

APPENDIX "C".

STATUS AND PAY OF RADAR RATINGS DURING TRANSITION TO THE R.C. AND R.P. BRANCHES.

Present Rating.	Pay per Diem.		On Receipt of this Order.	Pay per Diem.		When Qualified in Seamanship only.	Pay per Diem.		When Qualified in Fire Control or Plotting only.	Pay per Diem.		When Qualified in Seamanship and Fire Control or Plotting.	Pay per Diem.	
	(1) Substantive.	(2) Allowance.		(1) Substantive.	(2) Allowance.		(1) Substantive.	(2) Non-Substantive.		(1) Substantive.	(2) Allowance.		(1) Substantive.	(2) Non-Substantive.
C.P.O. (Radar)	<i>s. d.</i> 12 6	<i>s. d.</i> 0 3	C.P.O. (Radar) R.C. (P) or C.P.O. (Radar) R.P. (P)	<i>s. d.</i> 12 6	<i>s. d.</i> 0 3	C.P.O. R.C. 1 (P) or C.P.O. R.P. 1 (P)	<i>s. d.</i> 12 6	<i>s. d.</i> 1 6	C.P.O. (Radar) R.C. or C.P.O. (Radar) R.P.	<i>s. d.</i> 12 6	<i>s. d.</i> 1 0	C.P.O. R.C. 1 or C.P.O. R.P. 1	<i>s. d.</i> 12 6	<i>s. d.</i> 1 6
P.O. (Radar)	11 2	0 3	P.O. (Radar) R.C. (P) or P.O. (Radar) R.P. (P)	11 2	0 3	P.O. R.C. 1 (P) or P.O. R.P. 1 (P)	11 2	1 6	P.O. (Radar) R.C. or P.O. (Radar) R.P.	11 2	1 0	P.O. R.C. 1 or P.O. R.P. 1	11 2	1 6
Ldg. Seaman (Radar)	9 8	0 3	Ldg. Sea. (Radar) R.C. (P) or Ldg. Sea. (Radar) R.P. (P)	9 8	0 3	Ldg. Sea. R.C. 2 (P) or Ldg. Sea. R.P. 2 (P)	9 8	0 9	Ldg. Sea. (Radar) R.C. or Ldg. Sea. (Radar) R.P.	9 8	0 6	Ldg. Sea. R.C. 2 or Ldg. Sea. R.P. 2	9 8	0 9
Able Seaman (Radar)	8 6	0 3	Able Seaman (Radar) R.C. (P) or Able Seaman (Radar) R.P. (P)	8 6	0 3	Able Seaman R.C. (P) or Able Seaman R.P. 3 (P)	8 6	0 3	Able Seaman (Radar) R.C. or Able Seaman (Radar) R.P.	8 6	0 3	Able Seaman R.C. 3 or Able Seaman R.P. 3	8 6	0 3

Ord. Seaman (Radar)	5 6	0 3	Ord. Sea. (Radar) R.C. (P) or Ord. Sea. (Radar) R.P. (P)	5 6	0 3	Ord. Sea. A/R.C. 3 (P) or Ord. Sea. A/R.P. 3 (P) (see note 2)	5 6	0 3	Ord. Sea. (Radar) R.C. or Ord. Sea. (A/Radar) R.P.	5 6	0 3	Ord. Sea. A/R.C. 3 or Ord. Sea. A/R.P. 3 (see note 2)	5 6	0 3
---------------------	-----	-----	--	-----	-----	---	-----	-----	--	-----	-----	---	-----	-----

1. Existing Leading Seamen (Radar) are not required to undergo Radar course for 2nd-class rating.

2. The non-substantive rating of R.C. 3 or R.P. 3 can only be held by Ordinary Seamen on an acting basis; if otherwise qualified, they will be confirmed on advancement to A.B., but see the last sentence of paragraph 3 of this Order.

3. Only basic rates of substantive pay are shown. Progressive pay is payable as for seamen ratings (Naval Financial Regulations and Instructions, Article 35), but seniority as Ldg. Sea. (Radar), P.O. (Radar), and C.P.O. (Radar) does not count as seniority as Ldg. Sea., P.O., and C.P.O.

4. R.C. 1's. qualified from P.O. (Radar) may carry out a re-qualifying course in gunnery after twelve months (see paragraph 7 (ii)).

(This Order will be reprinted for posting on Notice Boards.)

(463/210/95.)

544.

AUSTRALIAN RED CROSS SOCIETY.

Approval has been granted to the request of the Australian Red Cross Society that it be regarded as an official Auxiliary to the Medical Services of the Royal Australian Navy and as a Voluntary Aid Society under the Geneva Convention. Such recognition has been extended also by the A.M.F. and R.A.A.F.

2. Members of Red Cross Units requiring accommodation and assistance in forward areas are attached normally to the A.M.F. Instances may occur in which no A.M.F. Units are present and in these cases attachment to R.A.N., or R.A.A.F., will be arranged. Full details of the conditions of any such attachment to the R.A.N. will be forwarded to the Naval Officer-in-Charge concerned.

3. In Ceylon, Australian Red Cross Units are attached to R.A.A.F.

(552/201/1184.)

545.

A.M.S. VESSELS—L.L. CABLE DRUMS—STIFFENING OF HAND WINDING GEAR.

With reference to Navy Order 339 of 1944, reports received from certain A.M.S. Vessels indicate that further modifications are necessary to the hand winding gear for L.L. sweep cable drums.

2. In vessels where the cranks of the hand winding gear are fitted with spindles and tubes, mild steel gusset plates are to be welded in at the junction of the cranks and spindles as shown on appended diagram.

(603/247/1710.)

**A.M.S. VESSELS.
STIFFENING OF CRANK FOR HAND TURNING GEAR
OF L. L. SWEEP REEL.**

NAVY OFFICE MELBOURNE	
DRG. NO 157/516/1 NY 1	
DATE: 21-9-44	
DRAWN BY	MINALON 21-9-44
TRACED BY	
CHECKED BY	W.E.H. 21-9-44
EXAMINED BY	S.H.C. 21-9-44
APPROVED	<i>[Signature]</i>

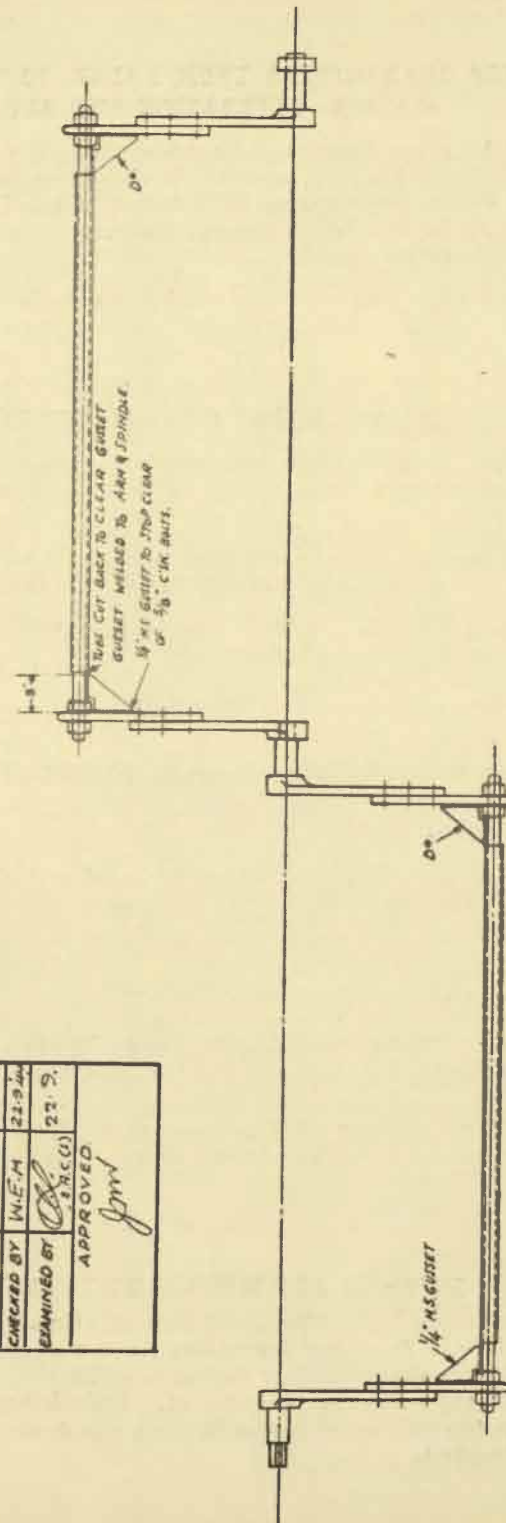

546.

RANGE TRANSMITTER FROM RADAR TO TRANSMITTING STATION—ALTERATION AND ADDITION.

H.M.A. Ships *Gascoyne*, *Burdekin*, *Barcoo*, and *Hawkesbury* are to raise a defect list item, to move the range transmitter from the A.286 office to the surface warning Radar office, if this has not already been carried out, in view of the increased accuracy and range of the latter set against surface targets.

2. The work is to be carried out by base staffs whenever possible.
(629/203/1868.)

547.

MISALIGNMENT OF SHAFTING IN M.Ls.

A report of serious misalignment between shafting and engines has been received, concerning a M.L. which has been in commission for four months.

2. If misalignment is suspected, a check is to be made on the first occasion of slipping, otherwise Navy Order 545 of 1943 is to be observed.

3. In either case a report is to be forwarded to the Naval Board stating the result of such examinations.

(603/297/348.)

548.

GUN MOUNTINGS—40 M.M. BOFORS—FORESIGHTS.

Admiralty Fleet Order 3531/44 will not apply to Australian Bofors gun mountings.

2. A three hundred knot sight is being designed for Australian Bofors mountings, and further instructions will be promulgated at a later date.

(612/209/205.)

549.

ANTI-GAS EYESHIELDS—PROTECTION.

Ships and Establishments which have not yet complied with paragraph 3 of Navy Order 209 of 1944 regarding the provision of cardboard cartons for the protection of anti-gas eyeshields should forward demands to the Superintending Naval Store Officer, Sydney, as soon as possible.

(669/201/1097.)

550.

INJURIES AND WOUNDS BY ENEMY ACTION.

The British War Office is desirous of obtaining statistics in regard to members of the Royal Australian Navy who are injured or wounded due solely to enemy action, stating whether they are (a) returned to duty, or (b) otherwise disposed of. This information is desired in addition to statistics of deaths through this cause which are at present being supplied.

2. Where a Medical Journal is rendered to Navy Office by a Medical Officer, particular care is to be taken to ensure that this class of wound or injury is entered on the correct line of Table III., Part 5, Form A.M. 179—Medical Journal, viz., "Wounds and Injuries in action" and *not* under the classification of "Local Injuries and Wounds, on duty, employment." Unless this is done, deaths due to enemy action will be wrongly classified.

3. In small vessels, where a sick berth rating only is carried, the Commanding Officer is responsible for the Medical Journal, with the exception of Part 5, Table III. thereof, which is compiled at Navy Office. When recording each wound or injury in the Alphabetical Sick List, Part 9, of the Medical Journal, particular care is to be taken to include, after the description of the disability, the words "due to enemy action."

(527/201/944.)

551.

NAVAL SALVAGE MONEY—DISTRIBUTION.

The award for the salvage of the Greek Ship "Mount Orthrys" by H.M.A.S. *Parramatta* on 8th May, 1941, has been received and authority issued for payment of amounts due to all members concerned.

2. The amounts due to individuals in the various classes are as follow:—

	£	s.	d.
Lieutenant Commander in Command ..	608	9	5
Lieutenant	52	15	11
Commissioned Officer from Warrant Rank ..	39	11	11
Warrant Officer	31	13	7
Chief Petty Officer	26	7	11
Petty Officer	21	2	4
Leading Seaman	15	16	9
Able Seaman	13	4	0
Ordinary Seaman	7	18	5

(401/201/2401.)

(This Order has been reprinted for posting on Notice Boards.)

552.

ISSUE OF MESS GEAR AND BLANKETS TO PERSONNEL TRAVELLING.

Issue of Water Bottle by Railway Transport Officers on Form A.T. 801.z. referred to in Navy Order 170 of 1944, is to be confined to personnel travelling on leave by troop train and road transport on the following routes:—

- (i) between Townsville and Darwin (via Mount Isa),
- (ii) between Adelaide and Darwin (via Alice Springs),
- (iii) between Melbourne and Perth.

Webbing gear is not to be included in issues of water bottles made by Railway Transport Officers.

2. Issues to personnel on draft are to be made by the drafting depot or ship in accordance with Navy Order 296 of 1940, as amended by Navy Order 84 of 1942. Instructions in regard to accounting for these issues are contained in Navy Order 246 of 1942.

(530/201/531.)

553.

SUGAR—CONSUMPTION OUTSIDE TERRITORIAL WATERS.

Attention is drawn to Navy Order 357 of 1944 which requires Commanding Officers to forward to the Director of Victualling monthly a certificate of the quantity of sugar received from Australian sources and consumed on board outside territorial waters.

2. It is desired to stress the importance of rendering these certificates promptly, and all sea-going ships, including tenders, which have omitted to comply with the provisions of Navy Order 357 are to forward forthwith certificates which are now due in respect of July and subsequent months, nil returns being forwarded where applicable.

(668/213/56.)

554.

BOOKS AND FORMS.

First supplies of the under-mentioned publications have been distributed:—

B.R.150 (Late B.R.150B).—Naval Manual of Aircraft Recognition—Amendment No. 4.

(A.F.O. 2016/44.)
(571/202/1646.)

B.R.296/44.—Handbook for the 4-in. B.L. Mortar, Mark I (N).

(A.F.O. 2403/44.)
(571/202/1614.)

B.R.347. D.116.—Establishment of Naval Stores for Trawlers and Corvettes ("Flower" Class)—Errata No. 1. List of Particulars—Errata No. 3.

(A.F.O. 889/44.)
(571/202/1492.)

B.R.375.—Establishment of Naval Stores for Fast Minelayers—Errata Nos. 4 and 5.

(A.F.O. 4369/43.)
(571/202/1358.)

B.R.664.—King's Regulations and Orders for the Army—Amendments Nos. 36 and 37.

(A.F.Os. 1428 and 2016/44.)
(571/203/126.)

B.R.821/43.—Handbook for 4-in. Mark XIX Gun on C.P., Marks XXIII, XXIII* and XXIII** Mountings.

(A.F.O. 6055/43.)
(571/202/1998.)

B.R.856.—Notes for Medical Officers attached to Landing Parties.

(A.F.O. 4768/43.)
(571/202/1844.)

B.R.876_N Series (Late C.B.409_N Series).—I.S.I.S. Report on Western Anatolia.

B.R.876_N (1)—(5) and (8).(A.F.O. 5661/43.)
(571/202/1928.)

B.R.876_R Series (Late C.B.4096_R Series).—I.S.I.S. Report on Thailand, July, 1942.

B.R.876_R (1)—(5) and (8).(C.A.F.O. P2/44.)
(571/202/1928.)B.R.877_J Series.—Short Glossary of Malaya.B.R.877_J Vol. 1, B.R.877_J (1) to (8).—Report on Malaya.B.R.877_J Vols. III and IV.—B.R.877_J, Part 1 Plans, Photographs.

(571/202/2013.)

B.R.987, Part IV.—Small Ships Firing Manual, Part 4 of the Firing Manual, 1944, Instructions for Escort Destroyers, Frigates and Corvettes.

(A.F.O. 2016/44.)
(571/202/2012.)

O.U.6092A.—Proportion Book of Naval Armament Stores, Errata Nos. 14 and 15.

(A.F.Os. 889 and 2016/44.)
(571/203/2481.)

O.U. 6353.—November and December Supplements and Amendments—British Merchant Vessels Lost.

O.U.6353A.—November and December Supplements and Amendments—Foreign Merchant Vessels Lost and Damaged by the Enemy.

(A.F.Os. 889 and 1428/44.)
(571/203/2460.)

A.P.1927.—Amendments Nos. 26—29—Air Force Code.

(571/201/4234.)

T.1/M.350.—Optimum Frequency Band Tables.

T.2/M.350.—Frequency Guide for the North and South Atlantic.

T.3/M.350.—Frequency Guide for the Indian Ocean.

T.4/M.350.—Frequency Guide for Shore—Ship Communication in the Indian Ocean.

(A.F.O. 2687/44.)
(571/202/2016.)

D.N.C.14 (IRPL A-9).—Recommended Frequency Bands for Ships and Aircraft in the Atlantic and Pacific, July, August, September, 1944.

D.N.C.14 (IRPL B-7).—Recommended Frequency Bands for Submarines in the Pacific (Supplementary to IRPL (A-9) July, August, September, 1944.

(571/202/2016.)

AVMETCO-2.—Forms and Methods of Coding for R/T and W/T Weather Messages between Aircraft and Ground or Ship Stations.

(571/201/3974.)

U.S. Army-Navy Journal of Recognition.—No. 6, February, 1944, No. 7, March, 1944.

(571/201/4346.)

O.N.I.54R.—U.S. Naval Ships and Aircraft—Amendments Nos. 4 and 5.

(571/201/4231.)

A.O.U.101 (2).—Commercial Call Signs allocated to R.A.A.F. and Australian Aeradio Stations, also Amendment No. 1.

(571/203/2521.)

Ordnance Pamphlet 951, Type 0.50, Machine Gun, Mk. 17, Modifications 1 and 2.

571/201/4220.)

Aircraft Recognition Photographs (Sets of 13 each set numbered S.1700 (1) to (13)).

(415/201/1946.)

Aircraft Recognition Journal, Volume 11, Nos. 1, 5, 6, 7 and 8.

(A.F.Os. 4882/43, 889, 1428, 2016 and 2686/44.)

(415/201/1879.)

B.R.781.—Handbook for the 2 pdr. Q.F. Mark II* C Gun, on single, Mark XV Mounting (Powered) has been rendered obsolete and all copies should be disposed of in accordance with the instructions laid down in B.R.1.

(A.F.O. 3593/44.)

(571/202/1795.)

2. The under-mentioned form has been introduced for use in the R.A.N., and first supply has been distributed from Navy Office. Demands for further requirements should be forwarded to the Superintending Naval Store Officer, Sydney.

A.S. 1210z—A/S Attack Test.

(480/202/4637.)

By Authority: H. E. DAW, Government Printer, Melbourne.

many
RESTRICTED

(FOR OFFICIAL USE ONLY.)

Commonwealth Navy Orders.

Navy Office, Melbourne,
24th October, 1944.

The following Orders, having been approved, are hereby promulgated for information and guidance, and necessary action.

By direction of the Naval Board,

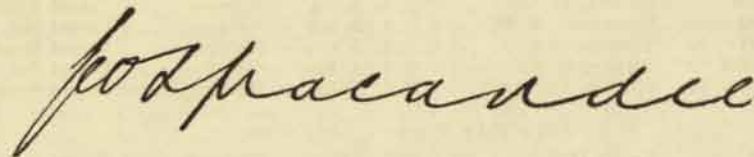

Secretary.

*The Commodore Commanding H.M.A. Squadron,
and Commanding Officers of H.M.A. Ships,
Officers in Charge of H.M.A. Naval
Establishments, and others concerned.*

TABLE OF CONTENTS.

No.	Subject.
555.	Examination of Engine Room Ratings.
556.	Advancement of Wiremen.
557.	Advancement of Communication Ratings in (or Attached to) Combined Operations.
558.	Air Sea Rescue Craft—Physical Standard of Personnel Serving in.
559.	Clips, Cartridge, No. 1 Mark I.
560.	Discrepancies in Stores Shipped—Reports A.D.690 and O.9.
561.	Compensation for Loss of Uniform—Officers and Ratings.
562.	Savings Bank Transactions in H.M.A. Ships.
563.	Butter, Concentrated, Hardened, Replacing Tropical Butter-fat Spread.
564.	Tropical Dress—Wearing Ashore on the Mainland.
C.11325/44.	

555.

EXAMINATION OF ENGINE ROOM RATINGS.

The following additional results of examination of Engine Room Ratings are promulgated for information:—

O.N.	Name.	Present Rating.	Application Received From.	Result.
<i>E.R.A. for C.E.R.A.</i>				
W/1258 ..	Anderson, J. T. ..	E.R.A. 3 ..	Lonsdale ..	Passed Sat.
24360 ..	Scott, J. C. ..	E.R.A. 3 ..	Cerberus ..	Passed Supr.
<i>E.R.A. A/4th Class for Confirmation.</i>				
PM/6080 ..	Boadle, E. V. ..	E.R.A. A/4th ..	Moresby ..	Passed Sat.
B/4598 ..	Bright, W. ..	E.R.A. A/4th ..	Townsville ..	Passed Supr.
S/8799 ..	Carlson, A. E. J. ..	E.R.A. A/4th ..	Glenelg ..	Passed Supr.
S/6099 ..	Caulfield, W. F. ..	E.R.A. A/4th ..	Ladava ..	Passed Sat.
PM/6624 ..	Coode, L. ..	E.R.A. A/4th ..	Lonsdale ..	Passed Sat.
D/MX. 75866	Dixon, A. S. ..	E.R.A. A/4th ..	Ariadne ..	Passed Supr.
PM/4310 ..	Falloon, J. D. ..	E.R.A. A/4th ..	Bungaree ..	Passed Supr.
W/1249 ..	Mathers, D. F. ..	E.R.A. A/4th ..	Gympie ..	Passed Supr.
PA/2036 ..	Pidgeon, S. A. ..	E.R.A. A/4th ..	B/S. T.I. ..	Passed Supr.
PM/3861 ..	Prewett, A. T. ..	E.R.A. A/4th ..	Doomba ..	Passed Sat.
H/2519 ..	Purdon, R. W. ..	E.R.A. A/4th ..	Moresby ..	Passed Supr.
B/3381 ..	Simmonds, A. R. ..	E.R.A. A/4th ..	Karangi ..	Passed Sat.
F/4691 ..	Thompson, A. F. ..	E.R.A. A/4th ..	Quiberon ..	Passed Supr.
PM/4494 ..	Tollens, D. F. ..	E.R.A. A/4th ..	Hobart ..	Passed Sat.
PM/6340 ..	Wallace, G. W. ..	E.R.A. A/4th ..	Bendigo ..	Passed Supr.
<i>Stoker Petty Officer for Chief Stoker.</i>				
21988 ..	Laing, G. ..	S.P.O. ..	Quiberon ..	Passed Supr.
21138 ..	Pipe, F. W. ..	S.P.O. ..	Lonsdale ..	Passed Supr.

2. The necessary notation should be made on Forms A.S.1233g and 1246a.

3. Forms A.S.442 for successful and unsuccessful candidates will be forwarded to Ships and Establishments concerned for signatures by the candidates. The original is to be retained by the candidate and the duplicate forwarded to the Commodore Superintendent of Training.

(465/207/1237.)

(This Order will be reprinted for posting on Notice Boards.)

556.

ADVANCEMENT OF WIREMEN.

As a temporary measure in order not to retard advancement, it has been decided that Wiremen and Leading Wiremen recommended for advancement to next higher rating, who cannot be advanced owing to not having completed the required course, can be advanced to the acting higher rating to fill a vacancy in Fleet numbers. It will be necessary for them to undergo the course when opportunity offers and failure to qualify after course will involve reversion to former rating.

(349/5/9.)

(This Order will be reprinted for posting on Notice Boards.)

3

557.

ADVANCEMENT OF COMMUNICATION RATINGS IN (OR ATTACHED TO) COMBINED OPERATIONS.

In order that the advancement of Communication ratings serving in or attached to Combined Operations is not overlooked, the directions contained in paragraphs 3, 4, and 5 of A.F.O. 2444/1944 are to be observed.

(349/16/375.)

558.

AIR SEA RESCUE CRAFT—PHYSICAL STANDARD OF PERSONNEL SERVING IN.

In view of the duties which will be carried out by Air Sea Rescue Craft, all officers and ratings appointed for duty therein are to conform to the physical standards laid down for R.A.N. and R.A.N.R. personnel in Navy Office letter 39334 of 10th October, 1940 (amending physical standard prescribed in "Recruiting Instructions"), and as regards officers in Table G of R.A.N. Physical Standards contained in that letter.

2. Visual standards are especially important, and all officers and ratings appointed for duty in Air Sea Rescue Craft must possess, without the aid of glasses, the necessary standard of vision as laid down in the instruction referred to above.

(527/201/931.)

559.

CLIPS, CARTRIDGE, No. 1 MARK I.

Two cases have occurred recently where Cartridges Q.F.4-in. for Mark XIX guns have fired prematurely through falling or sliding base first with sufficient force to crush the dome of the protecting clip far enough to impinge on the cap of the percussion primer.

2. Protecting clips are designed to protect the primer caps from a direct blow on the cap, but do not give immunity when a round is dropped and the cap crushed.

3. All Clips No. 1 Mk. I A.N. are being reformed to ensure that the height of dome is correct in order that maximum protection may be afforded against a direct blow.

4. Ships, Establishments and D.E.M.S. Staff are to examine all cartridges for 4-in. Mark XIX guns for Clips cartridge No. 1 Mk. I A.N. which do not bear the letter "R" indicating that they have been reformed.

5. Demands are to be forwarded to the nearest Armament Depot for clips to replace all those marked as in paragraph 4 above. The clips are to be retained until replacements are received, when they are to be returned to the nearest Armament Depot.

6. Armament Depots are to return all clips marked as in paragraph 4 above to the Deputy Armament Supply Officer, Maribyrnong, for reforming.

(408/207/2263.)

560.

DISCREPANCIES IN STORES SHIPPED—REPORTS A.D.690 AND O.9.

Reports A.D.690 and O.9 in regard to the receipt of naval victualling and ordnance stores are to be rendered to Navy Office in future only in respect of those differences due to surpluses, deficiencies, and damages amounting to over £1 in value in any individual invoice. Differences of £1 or less in value are to be adjusted by the consignee.

2. In order to comply with statutory requirements, quarterly statements of differences adjusted locally are to be forwarded to the Directors concerned at Navy Office for covering approval, as necessary.

3. This does not apply to medical stores.

4. The local adjustment referred to in paragraph 1 does not dispense with the necessity of rendering claims in such cases against shipping companies or State Railways in the normal manner. In respect of the latter, however, Navy Order 554 of 1943 is still applicable.

5. Navy Order 684 of 1943 is hereby cancelled.

(612/254/162.)

561.

COMPENSATION FOR LOSS OF UNIFORM—OFFICERS AND RATINGS.

With reference to Naval Financial Regulations and Instructions, Article 56, it has been decided that, in future, claims for ratings for compensation for total loss of, or damage to, uniform and clothing as a result of a Service casualty may be dealt with by Commanding Officers on the following revised basis:—

(a) *Total Loss of Articles.*—Provided the conditions laid down in K.R. & A.I., Article 1697, clause 1, are fulfilled, compensation based on the current issuing price of new articles may, at the discretion of the Commanding Officer, be allowed in full, either in cash or kind, for all losses of compulsory and optional articles within the quantities

of the regulation kit laid down in the authorized R.A.N. scales (Naval Financial Regulations and Instructions, Article 46 as amended to date and modified by Navy Orders 172 of 1939 and 204 of 1943) for the rating concerned, and no deduction should be made in respect of any articles over and above the regulation kit remaining in the rating's possession after the loss.

(b) *Damaged Uniform.*—The above procedure also applies to claims in respect of damage to uniform except that the amount of compensation awarded is to be based on the estimated reduction in value of the articles as a result of the damage, i.e., the difference in value immediately before and after the damage. When articles are damaged beyond repair, full compensation may be allowed.

2. Full particulars of compensation awarded by Commanding Officers in cash and/or in kind under the above authority, whether as advance of compensation pending finalization of the claim by next Ship or Establishment, or in total satisfaction of the claim, are to be submitted, without delay, to the Naval Board, by separate memorandum, for covering approval.

3. Claims of Officers for compensation in respect of total loss of, or damage to, uniform and clothing articles as a result of a Service casualty, are to continue to be submitted to the Naval Board for consideration.

4. Navy Orders 47 of 1942 and 147 of 1944 are hereby cancelled.

(438/204/208.)

562.

SAVINGS BANK TRANSACTIONS IN H.M.A. SHIPS.

Where approval is given, under the provisions of Naval Account Regulations and Instructions, Article 141, clause 2, to the adjustment of excess Savings Bank deposits and withdrawals through Ships' Cash Accounts, the following accounting procedure is to be observed:—

(i) Excess deposits should be credited to "Naval Appropriations Suspense Account."

(ii) Excess withdrawals should be debited to "Trust Fund—Other Trust Moneys."

2. Naval Account Regulations and Instructions will be suitably amended in due course.

(584/205/77.)

563.

BUTTER, CONCENTRATED, HARDENED, REPLACING TROPICAL BUTTER-FAT SPREAD.

Butter, concentrated, hardened, is available to sea-going ships without refrigerated storage at the ports of Brisbane, Townsville, and Cairns. Demands should be made on the Officer-in-Charge of the Victualling Depot at port of supply. Supplies may also be obtained from Army stocks at other Northern ports, when available. For rationing purposes, this article is to be treated as butter after reconstitution in accordance with the directions on the tin, but such reconstitution with water is not essential before consumption if facilities for mixing are not available.

2. Because of its high melting point, hardened butter is particularly suitable for use in tropical areas instead of tinned butter, its advantages being pronounced at temperatures between 85° and 100° F.

3. Hardened butter can be safely carried for several months in the ship's store rooms, and for this reason is most suitable for ships without refrigerator accommodation.

(668/205/226.)

564.

TROPICAL DRESS—WEARING ASHORE ON THE MAINLAND.

In populous areas on the mainland, where climatic and other conditions render it desirable or essential, the Senior Officer may, at his discretion, grant permission for Number 13 dress for officers and Number 10 dress for ratings, to be worn by personnel on duty ashore and afloat and by personnel when on leave, having due regard to the provisions of paragraph 2. A black tie may be worn with shirts with this rig, if in the opinion of the Senior Officer the social conditions warrant it.

2. In areas south of the latitude of Brisbane, the wearing of tropical rig by personnel on long or short leave may be permitted by day only during the summer months. Tropical rig is not to be worn at official functions in these areas.

(434/210/224.)

RESTRICTED.(FOR OFFICIAL USE ONLY.)

Commonwealth Navy Orders.

Navy Office, Melbourne,

31st October, 1944.

The following Orders, having been approved, are hereby promulgated for information and guidance, and necessary action.

By direction of the Naval Board,

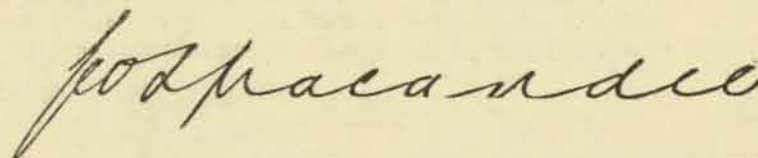

Secretary.

*The Commodore Commanding H.M.A. Squadron,
and Commanding Officers of H.M.A. Ships,
Officers in Charge of H.M.A. Naval
Establishments, and others concerned.*

TABLE OF CONTENTS.

No.	Subject.
565.	Diving Non-Substantive Rating.
566.	Gun-Mountings 4-in. Mk. XXIII and XXIII*—Lubrication of Centre Pivot.
567.	O.Q.F. 40 M.M. Bofors Mk. I* of Australian Manufacture—Springs, Striker, Breech Block—Examination.
568.	Guns Machine Bren 0.303-in.—Boxes, Magazine, Mk. I—Modification.
569.	Storage of Explosives in Buildings other than Magazines or Explosives Stores.
570.	Rockets Illuminating 3½ lb.—Failure of.
571.	Withdrawal of Electrical Demolition Stores.
572.	Medical Attention—W.R.A.N.S.
573.	Books and Forms.
574.	Corrigendum.

565.

DIVING NON-SUBSTANTIVE RATING.

The provisions of A.F.O. 6207/1943 have been adopted in the R.A.N., and Wiremen will now be eligible to hold the non-substantive rate of Diver 2nd Class.

(This Order will be reprinted for posting on Notice Boards.)

(349/28/88.)

566.

GUN-MOUNTINGS 4-IN. MK. XXIII AND XXIII*—LUBRICATION OF CENTRE PIVOT.

The centre pivots of Gun Mountings 4-in. Mk. XXIII and XXIII* are to be lubricated with Oil, Special Mineral Lubricating.

2. The publication "Guide to the Care and Maintenance of 4-in. Mk. XIX gun on the Mk. XXIII Mounting" is to be amended on page 3 by deleting "Grease Stauffer 'C' or Cooper's No. 4" and substituting "Oil, Special Mineral Lubricating."

3. B.R. 821/43, "Handbook for 4-in. Mk. XIX Gun on the C.P. Marks XXIII, XXIII*, XXIII** Mountings," is to be amended as follows:—Paragraph 33 (page 8), delete "A Grease Cap has been fitted in the upper racer plate for lubrication of the pivots assembly," and insert "An Oil Cup has been fitted, &c." Plate 9 of the same publication is to be amended by deleting "Grease Cap" and substituting "Oil Cup."

(490/203/1230.)

567.

O Q F. 40 M.M. BOFORS MARK I* OF AUSTRALIAN MANUFACTURE—SPRINGS, STRIKER, BREECH BLOCK—EXAMINATION.

A number of 40 m.m. Bofors Mark I* guns of Australian (M.O.) manufacture have been issued to service with the inner and outer striker springs wound the same way. This is unsatisfactory as the inner spring is not properly supported, with a risk of premature fatigue, and fracture of the springs and of jams which might cause serious damage to the breech mechanism.

2. All springs, striker, breech block, both component and spare, for guns of Australian manufacture are to be examined at the first opportunity, and demands raised on the nearest Naval Armament Depot to replace all outer springs which are not right hand wound and all inner springs which are not left hand wound.

3. As a temporary measure, until sufficient right hand wound outer springs and left hand wound inner springs can be made available, depots and bases are to endeavour to effect exchanges to ensure that the springs fitted in guns are wound to opposite hand.

4. Springs wound to the wrong hand are to be returned to Naval Armament Depots for disposal when replacements are received.

5. The blow of the striker is to be tested when component springs are replaced.

6. *Naval Armament Depots only*—If stocks are insufficient to meet all demands immediately, issues should be restricted in the first instance to those required to replace component springs.

(490/212/1168.)

568.

GUNS MACHINE BREN 0-303-IN.—BOXES. MAGAZINE. MARK I—MODIFICATION.

The modification to Boxes Magazine Mk. I for Guns Machine Bren referred to in A.F.O. 3555/43 is being adopted in the R.A.N. only in respect of Boxes issued to H.M.A. Ships for use by Naval landing parties.

2. Ships concerned are to demand modified boxes as required from the nearest Naval Armament Depot or Base and on receipt are to land a corresponding quantity of unmodified boxes.

3. Naval Armament Depots and Bases are to demand the modified boxes from the Superintending Armament Supply Officer, Sydney, to whom unmodified boxes are to be returned in due course.

(490/212/1097.)

569.

STORAGE OF EXPLOSIVES IN BUILDINGS OTHER THAN MAGAZINES OR EXPLOSIVE STORES.

It has come to the notice of the Naval Board that, at some Ports, use is being made of buildings other than Magazines and Explosive Stores for the storage of ready-use ammunition.

2. This practice is to cease forthwith, and suitable arrangements are to be made at each Port so that ammunition landed by H.M.A. Ships or discharged from freight vessels is transferred immediately from the ship to the magazine area without making use of any unauthorized temporary stowage, other than Ammunition Lighters or Ammunition Trucks, but the latter must always be parked in a magazine area when loaded.

3. Demands for ammunition from H.M.A. Ships and D.E.M.S. must be made in sufficient time to allow for transport from the magazine area, as no ready supply will be available elsewhere.

4. This Order is not intended to preclude the use of ammunition dumps in operational areas where magazines are not provided.

5. A small ready-use supply of ammunition for small arms may be retained for the use of sentries if necessary, in a suitable building allocated for the purpose by the Naval Officer-in-Charge. The location of the building and the maximum quantity of small arms ammunition to be kept therein should be laid down in the Port Orders.

(525/201/776.)

570.

ROCKETS ILLUMINATING 3½ LB.—FAILURE OF.

Navy Order 388 of 1942, referring to the withdrawal of Rockets Illuminating 3½ lb. Lot M.E. 8-41, is hereby cancelled.

(471/208/926.)

571.

WITHDRAWAL OF ELECTRICAL DEMOLITION STORES.

It has been decided that, in future, Australian Minesweeping Vessels (Bathurst Class) will not carry electrical demolition stores. Therefore Detonators electric No. 21 are to be landed by all Australian Minesweeping Vessels at the first opportunity. This will make the issue of electric cable unnecessary.

2. Warrants for Naval Armament Stores will be amended accordingly.

(471/201/1538.)

MEDICAL ATTENTION—W.R.A.N.S.

Arrangements have been made in H.M.A.S. *Torrens* and *Harman* for the services of a woman doctor to be made available for W.R.A.N.S. who prefer to consult a doctor of their own sex, and where the circumstances of the case are considered to justify this course.

2. Dr. Elma Sandford Morgan, M.B., Ch.M., will attend H.M.A.S. *Torrens* one half-day each week for the purpose of giving medical attention to members of the W.R.A.N.S. She is also available for visiting members sick on shore or for consultation at her surgery, subject to approval from the District Naval Medical Officer. The following is Dr. Morgan's scale of fees:—

	£	s.	d.
Attendance for half-day	1	1	0
Visit to member of W.R.A.N.S. Sick on Shore ..	0	10	6
Visit of member to Doctor's Surgery	0	7	6

3. Dr. Moya K. Blackall, M.B., B.S. (Sydney), D.R.C.O.G. (England) is available for attendance at her surgery by appointment, on members of the W.R.A.N.S. serving in H.M.A.S. *Harman*, and will also visit them in Canberra Community Hospital, if considered necessary. Fees for Dr. Blackall's services are—

	£	s.	d.
Visit of member to Surgery	0	10	6
Attendance on member in Hospital—			
Single visit	0	10	6
Per week	2	2	0

4. Visits to these doctors should be confined to cases of such a nature as to render the services of a woman doctor desirable. Ordinary cases are to be treated by existing Service facilities.

(527/211/1954.)

BOOKS AND FORMS.

Copies of B.R.67, Seamanship Manual, Volume I, are now available for issue on repayment. Accountant Officers are requested to arrange for demands, as necessary, to be placed on the Superintending Naval Store Officer, Sydney. The price of this publication is 7s.

(571/202/1869.)

2. Supplies of the under-mentioned form will be printed in future instead of mimeographed as hitherto. Stock will be maintained at Navy Office and requirements should be demanded from the Director of Naval Stores as necessary:—

N.M.T.3.—Motor Transport Monthly Record.

(638/202/1691.)

CORRIGENDUM.

With reference to Navy Order 523 of 1944—"Books and Forms"—for the form "Report of Lighting of Vessels at Sea" read "Report of Sighting of Vessels at Sea."

By Authority: H. E. DAW, Government Printer, Melbourne.

RESTRICTED.(FOR OFFICIAL USE ONLY.)**Commonwealth Navy Orders.**

Navy Office, Melbourne,
7th November, 1944.

The following Orders, having been approved, are hereby promulgated for information and guidance and necessary action.

By direction of the Naval Board,

J. O. Macarandee
Secretary.

*The Commodore Commanding H.M.A. Squadron,
and Commanding Officers of H.M.A. Ships,
Officers in Charge of H.M.A. Naval
Establishments, and others concerned.*

TABLE OF CONTENTS.

No.	Subject.
575	Examination for Petty Officer Writer and Supply Petty Officer.
576	Passages to Australia for Dependants of Members of the Forces who have Married Abroad.
577	40-m.m. Bofors Mk. I and I* (Naval) Australian Manufacture—Fitting of Bracket, Catch Rear, Operating Lever.
578	Ordnance Q.F. 40-m.m. Bofors—E.F.C. Values.
579	Modification to O.Q.F. 4.7-in. Mk. XII, XII* and XIIB Breech Mechanism.
580	"Stripped"—303-in. Lewis Guns—Allowances.
581	Medical Stores—Scale "E" and Coxswain's Set of First Aid Instructions—Booklet—1944.
582	Tool Kits for Torpedo Ratings and Wiremen.
583	Enemy Ammunition.
584	Convoy Signal Ratings.
585	Guns Machine Oerlikon 20-m.m.—Springs Barrel Mk. II.
586	20-m.m. Oerlikon—One Man Cocking Device—Addition to Navy Order 261 of 1944.

575.

**EXAMINATION FOR PETTY OFFICER WRITER AND SUPPLY
PETTY OFFICER.**

Commencing with the examinations in March, 1945, the following changes are to be brought into effect:—

Petty Officer Writer.

	Marks	Time Allowed
(a) Ledger, ship's office work, pay accounts and regulations affecting same	250	3 hours
(b) Captain's Secretary work, Admiralty Instructions	200	2½ hours
(c) Arithmetic	100	No change
(d) Typewriting	50	No change

Optional.

(e) Shorthand	50	No change
-----------------------	----	-----------

An aggregate of 360 marks (60%) and 50% in each obligatory subject is required for a pass.

Supply Petty Officer.

	Marks	Time Allowed
(a) Arithmetic	100	No change
(b) Victualling	230	3 hours
(c) Naval Stores	230	3 hours
(d) Typewriting	40	No change

An aggregate of 360 marks (60%) and 50% in each subject is required for a pass.

2. C.O.R., Articles 197 and 198, will be amended in due course.

(465/207/1236.)

(This Order will be reprinted for posting on Notice Boards.)

576.

**PASSAGES TO AUSTRALIA FOR DEPENDANTS OF MEMBERS OF
THE FORCES WHO HAVE MARRIED ABROAD.**

With reference to Navy Order 600 of 1943, the Migration Officer, Australia House, London, advises that passage arrangements for wives cannot be completed until he has been advised by the Repatriation Commission, Australia, that husbands have actually arrived in Australia or are serving in a ship based thereon.

(632/211/973.)

577.

**40-M.M. BOFORS MK. I AND I* (NAVAL) AUSTRALIAN
MANUFACTURE—FITTING OF BRACKET, CATCH REAR,
OPERATING LEVER.**

Navy Order 486 of 1944, paragraph 1, is to be amended as follows:—

New parts required:—

Delete "2 No. ¾-in. Whit. Securing Screws" and substitute "2 No. ¾-in. B.S.F. Securing Screws".

(490/212/1141.)

578.

ORDNANCE Q.F. 40-M.M. BOFORS—E.F.C. VALUES.

Admiralty Fleet Order 2343/44 states that the lives of 40-m.m. Bofors Barrels are to be re-assessed at 4,000 E.F.C., one round filled F.N.II., N.H. or N.C.T. being taken as one E.F.C.

2. To conform with this instruction, rounds filled with cordite W., W.T., or W.M.T., are to be re-assessed as 5E.F.C. Memoranda of inspection are to be amended accordingly.

3. Pencil notes to this effect are to be inserted in B.R. 291, Table C, and in A.F.O. 4522/43.

4. As two barrels are supplied for every Mark I gun fitted in R.A.N. Ships, and D.E.M.S., barrels for these guns will not normally be exchanged until the condemning limit is reached, *vide* A.F.O. 2343/44, paragraph 4, care is to be taken that both barrels supplied for a gun do not wear out simultaneously. So far as is practicable, one barrel should be regarded as "spare", and used only when the other has been worn out or is over-heated in action.

(471/202/1371.)

579.

**MODIFICATION TO O.Q.F. 4.7-IN. MK. XII, XII* AND XII B
BREECH MECHANISMS.**

Trouble has been experienced with 4.7-in. Marks XII, XII* and XII B guns owing to the upper catch retaining breech block drooping and fouling the extractors, due to difficulty in retaining the axis pin securely.

2. B.R. 967, plate 3, shows the existing method of retaining the axis pins, by 0.7-in. diameter countersunk Cheese Headed Screws.

3. As a temporary modification, it is approved to fit a distance piece as shown in the diagrams (D.O.T.M. 79208 and 79209) appended to this Order.

4. This modification is to be carried out by Ships' Staffs or Armament Depots where considered necessary.

(490/201/1972.)

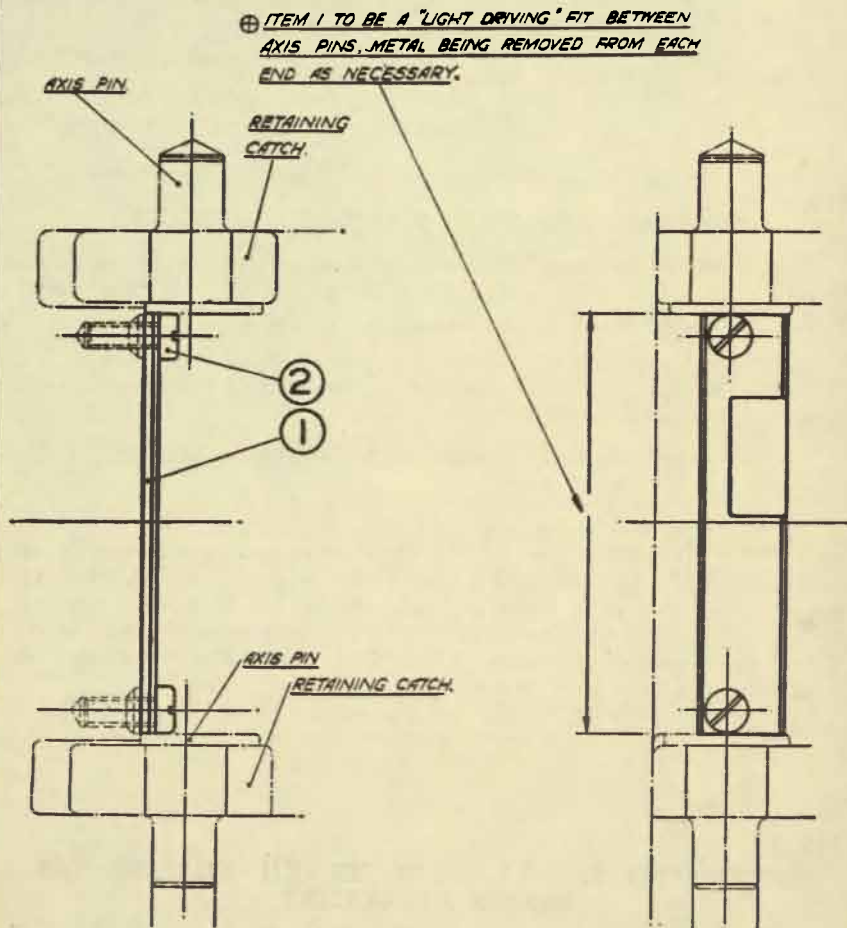
ARRANGEMENT.*(AS DRAWN FOR L.H. GUNS, TYPICAL FOR R.H. GUNS)*

ORDNANCE, Q.F., 4.7 IN., MKS. XII, XII* & XII B. - FOR GUNS ON 4.7" TWIN MARK XIX MOUNTINGS.
CATCH, RETAINING, BREECH BLOCK OPEN.

INSTRUCTIONS TO GUIDE FITTING OF BAR, FIXING, TO PREVENT FOULING OF RETAINING CATCH DUE TO EXCESSIVE MOVEMENT OF AXIS PIN.

D.O.T.M. 79208

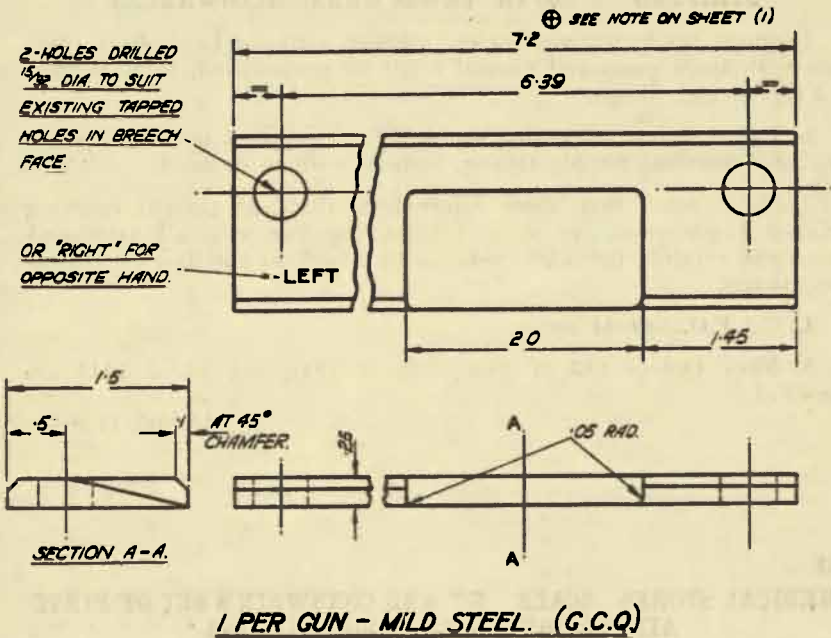
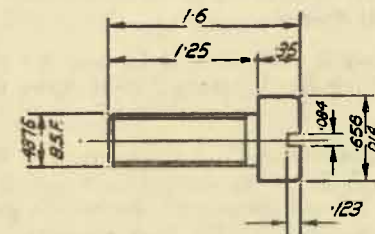
*(AS DRAWN FOR L.H. GUN, OPPOSITE HAND FOR R.H. GUN.)***2 PER GUN - CLASS 2 STEEL.**

DIMENSIONS ARE IN INCHES.

ORDNANCE, Q.F., 4.7 IN., MKS. XII, XII* & XII B. - FOR GUNS ON 4.7" TWIN MARK XIX MOUNTINGS.
CATCH, RETAINING, BREECH BLOCK OPEN.

BAR, FIXING. - DETAILS OF -

D.O.T.M. 79209.

580.

"STRIPPED"—·303-IN. LEWIS GUNS—ALLOWANCES.

Approval has been given for one ·303-in. stripped Lewis Gun, complete with spare parts and normal outfit of ammunition, to be carried in Frigates and Sloops.

2. The guns and associated stores will be supplied by the Superintending Armament Supply Officer, Sydney, without demand.

3. Ships, other than those referred to above, at present carrying stripped Lewis guns, are to land them, together with all associated stores not required for other weapons on board, at the first convenient opportunity.

4. C.A.F.O. 589/44 refers.

5. Navy Orders 243 of 1940, 222 of 1941 and 56 of 1943 are cancelled.

(612/205/1159.)

581.

MEDICAL STORES—SCALE "E" AND COXSWAIN'S SET OF FIRST AID INSTRUCTIONS—BOOKLET—1944.

The above-mentioned booklet, which was originally issued with each Scale "E" Medical Chest, has been completely revised and contains much added matter.

2. Copies have been distributed to all vessels known to carry Scale "E" Chest of Medical Stores.

3. This type of chest is allowed to M.Ls. and Air Sea Rescue Vessels which do not bear a Sick Berth rating. (See Navy Orders 44 and 685 of 1943.)

4. Naval Officers-in-Charge, Port Directors, &c., to whose command such vessels are attached are to ensure that action is taken by the Commanding Officers of such vessels to obtain this publication as early as possible if a copy has not already been received.

(612/213/2734.)

582.

TOOL KITS FOR TORPEDO RATINGS AND WIREMEN.

Several instances have been brought to notice of tools issued to Torpedo Ratings and Wiremen in accordance with C.O.R., Article 404, being of unsuitable type, e.g., screwdrivers with handles not completely insulated.

2. Arrangements should be made in such cases for the tools in question to be returned to store and for the issue of replacement items.

(524/214/802.)

583.

ENEMY AMMUNITION.

Attention is drawn to King's Regulations and Admiralty Instructions, Article 1073, clause 23, paragraph (c).

2. Permission is not to be given to individuals to embark enemy ammunition in H.M.A. Ships, and attention is drawn to the danger of attempting to "souvenir" or tamper with enemy equipment because of ignorance as to its nature and the risk of "booby traps".

3. The discovery of enemy equipment which may appear to be of value or interest should be reported to the nearest R.M.S. and B.S. Officer and left untouched.

(432/219/4066.)

584.

CONVOY SIGNAL RATINGS.

The following amendment is to be made to Navy Order 69 of 1942, paragraph 3:—

Amend "A.F.O. 3296/1940" and "A.F.O. 4124/1941" to read "A.F.O. 1483/1944", in both places.

(349/16/365.)

585.

GUNS MACHINE OERLIKON 20 M.M.—SPRINGS BARREL MK. II.

The instruction contained in paragraph 1 of Admiralty Fleet Order 2606/44, relative to using up of Springs, barrel Mk. I before Mk. II barrel springs are used, is to be observed in the Royal Australian Navy. Mk. II barrel springs will not therefore be issued until stocks of Mk. I springs are exhausted.

(490/212/1150.)

586.

20-M.M. OERLIKON—ONE MAN COCKING DEVICE—ADDITION TO NAVY ORDER 261 OF 1944.

With reference to Navy Order 261 of 1944 and diagram, the dimensioned parts are suitable only for American Mk. IV and V Mounting.

2. The diagrams appended to this Order (D.O.T.M. 84751, 84752, 84753 and 84754) show the dimensions of parts required when fitting this device to Mountings Mk. IIA, IIIA, IV, V and VIIA.

(490/212/1020.)

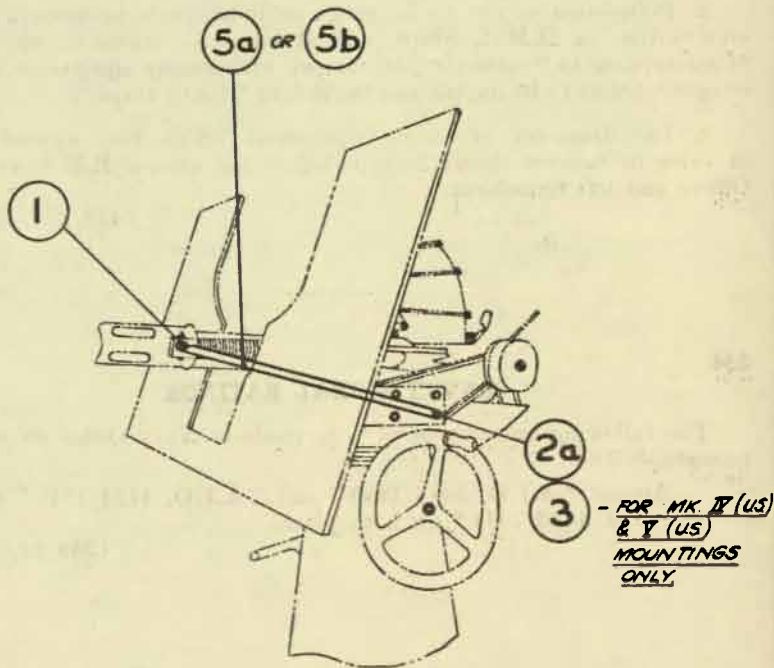

ARRANGEMENT (DIAGRAMMATIC.)

EXISTING PARTS CHAIN DOTTED.
NEW PARTS FULL LINE.

FOR DETAILS SEE DIAGRAMS D.O.T.M. 84753 & 84754.

GUN, MACHINE, OERLIKON, 20 M.M.
ON MARK II A, III A, IV (U.S.) OR V (U.S.)
MOUNTINGS.

D.O.T.M. 84751.

MODIFICATION FOR ONE MAN QUICK ACTING COCKING DEVICE.

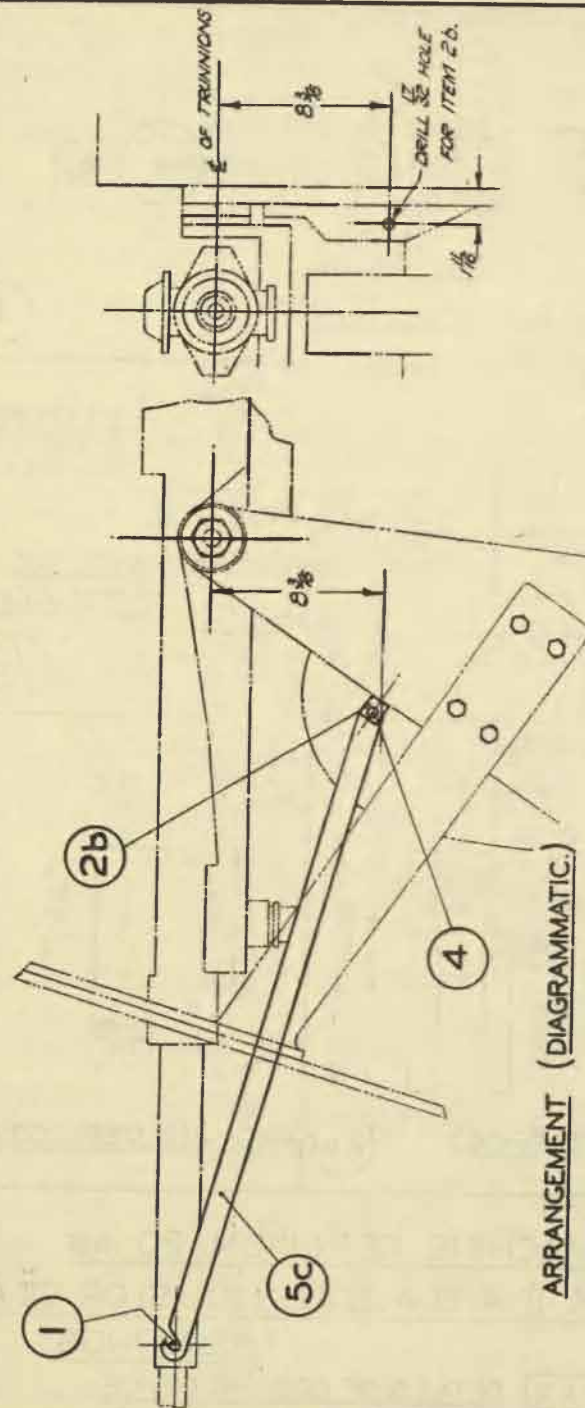

ARRANGEMENT (DIAGRAMMATIC.)

EXISTING PARTS CHAIN DOTTED.
NEW PARTS FULL LINE.

FOR DETAILS SEE, DIAGRAMS D.O.T.M. 84753 & 84754.
DIMENSIONS ARE IN INCHES.

GUN, MACHINE, OERLIKON, 20 M.M.
ON MARK VII A. MOUNTING.

D.O.T.M. 84752

MODIFICATION FOR ONE MAN QUICK ACTING COCKING DEVICE.

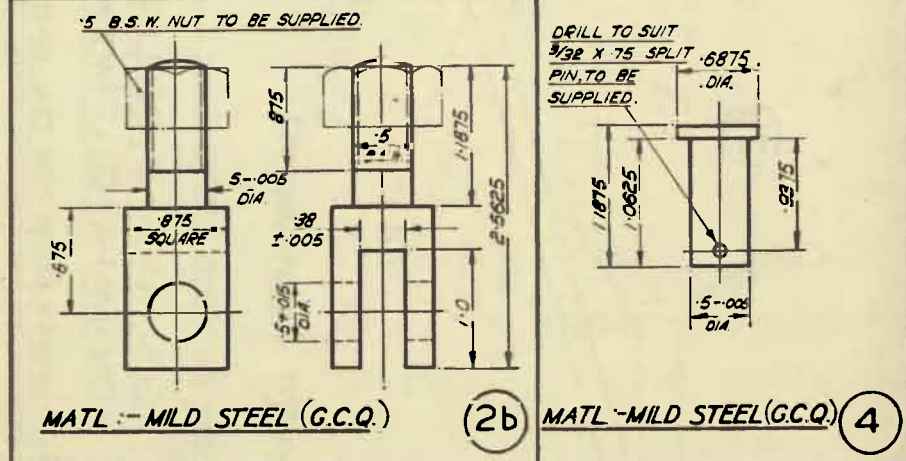
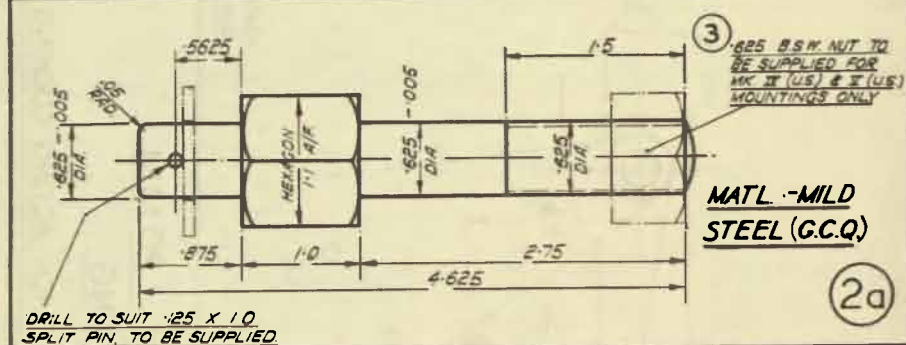
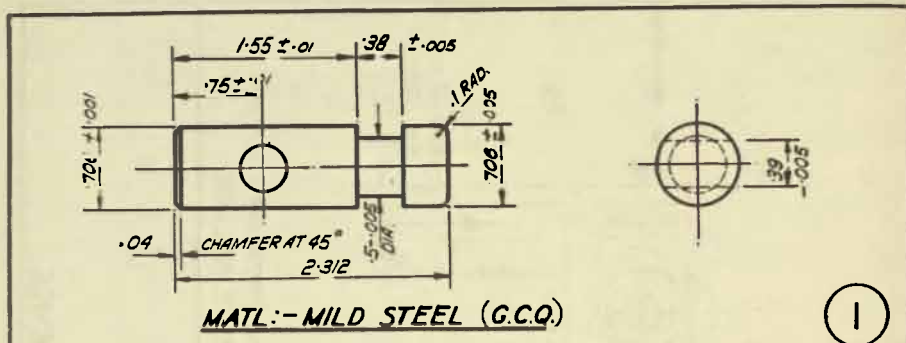

DIMENSIONS ARE IN INCHES

GUN, MACHINE, OERLIKON, 20 mm.
ON MK. II A, III A, IV (U.S.), V (U.S.) OR VII A,
MOUNTINGS.

D.O.T.M. 84753. DETAILS OF COCKING DEVICE.

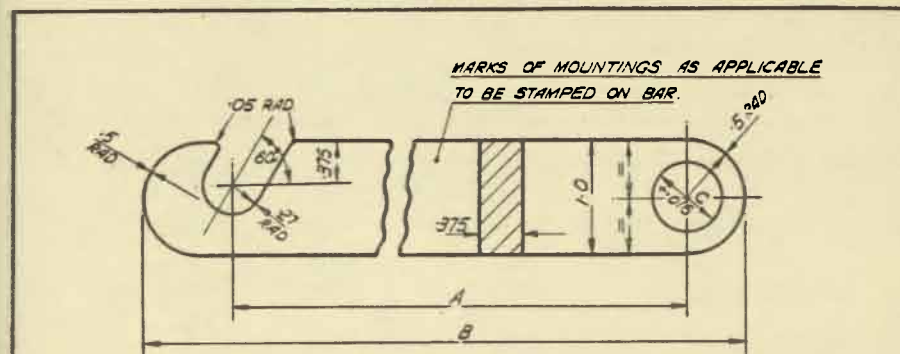

MATL:—MILD STEEL BAR 10 X 375 (G.C.Q.)

ITEM NO	DIMENSIONS		
	A	B	C
5 a.	24.75	26.0	625
5 b.	25.5	26.75	625
5 c.	30.625	31.875	.5

LIST OF COMPONENTS.

ITEM NO	D.O.T.M. NO	DESCRIPTION	NO PER SET				
			II A	III A	IV (U.S.)	V (U.S.)	VII A
1	84753	STUD, COCKING. (GUN COMPONENT.)	1	1	1	1	1
2 a.	84753	PIVOT BAR, COCKING WITH 5/8 WASHER AND SPLIT PIN 1/8 X 1.0.	1	1	1	1	-
2 b.	84753	PIVOT BAR, COCKING WITH 1/2 B.S.W. NUT.	-	-	-	-	1
3	-	5/8 B.S.W. NUT FOR ITEM 2 a.	-	-	1	1	-
4	84753	PIN, PIVOT, FOR ITEM 2 b. WITH SPLIT PIN 3/32 X 3/4	-	-	-	-	1
5 a.	84754	BAR, COCKING.	1	1	-	-	-
5 b.	84754	" "	-	-	1	1	-
5 c.	84754	" "	-	-	-	-	1

DIMENSIONS ARE IN INCHES

GUN, MACHINE, OERLIKON, 20 mm.
ON MK. II A, III A, IV (U.S.), V (U.S.) OR VII A,
MOUNTINGS.

D.O.T.M. 84754. DETAILS OF COCKING DEVICE.

RESTRICTED.(FOR OFFICIAL USE ONLY.)

Commonwealth Navy Orders.

Navy Office, Melbourne,
14th November, 1944.

The following Orders, having been approved, are hereby promulgated for information and guidance, and necessary action.

By direction of the Naval Board,

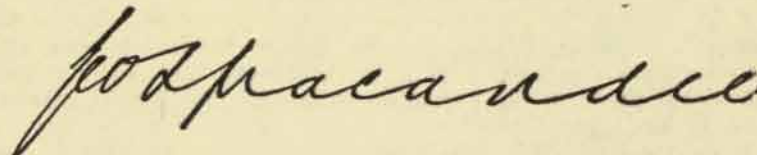

Secretary.

*The Commodore Commanding H.M.A. Squadron,
and Commanding Officers of H.M.A. Ships,
Officers in Charge of H.M.A. Naval
Establishments, and others concerned.*

TABLE OF CONTENTS.

No.	Subject.
587.	Supply Branch.
588.	Special Advancements of Outstanding Men in Seagoing Ships.
589.	Good Conduct Badges—Counting of Previous Service Towards Award.
590.	A.M.S. Vessels Fitted with Brown Type "A" Gyro Compass— Replacement of 2 mfd. Condensers in Transmitter Spark Quench Circuit.
591.	8-in. Shell Grabs—"Screw Down" Type.
592.	4-in. Mark XXIII and XXIII ¹ Gun Mountings.
593.	Guns and Mountings—20 m.m. Oerlikon.
594.	Bright Steel Bolts, Nuts and Studs Manufactured from Marbrite Free Cutting Steel.
595.	Muster of Binoculars, Telescopes, Watches and Heliographs.
596.	Respirators Anti-Gas (Light Type).
597.	R.A.N. Women's Services—Calculation of Time.
598.	Counterpanes, Coverlets and Mattress Covers—Return to Store of Numbers Held in Excess of Allowances.
599.	Australian Army Canteens Service Issuing Points.
600.	B.R. and O.U. Books Account.
601.	Forms S.102 and S.103—Records of Issue and Return of Loan Clothing.
602.	Books and Forms.
603.	Lubricating Oils and Greases—Standardization and Purchase.
604.	London Correspondence.
605.	Food Coupons—Naval Personnel.
606.	War Comforts Forwarded to H.M.A. Ships and Establishments— Acknowledgment of.

587.

SUPPLY BRANCH.

In order to achieve greater efficiency in the Supply Branch during the war, the two sections, viz. (a) Victualling Stores and (b) Naval Stores will be separated, and the following procedure will be adopted for the employment and advancement of Supply personnel.

2. As far as practicable, Supply Assistants will be trained in both sides, and will be required to possess practical knowledge of one side and theoretical knowledge of the other, as at present, to qualify for Leading Rate (Navy Order 33 of 1942).

3. Leading Rates and above will, for drafting purposes, be divided into two sections. The practical knowledge on passing for Leading Rate will determine the section to which a dating will then be allocated, and should be clearly shown on the passing certificate in accordance with paragraph 2 of the above quoted Navy Order.

4. To qualify for advancement to Acting Supply Petty Officer (Tempv.), a Leading Supply Assistant will be required to pass, at the half-yearly examinations, papers in Arithmetic and Typing and a professional paper in the particular section of the Supply Branch to which he has been allocated.

5. Qualification for permanent advancement to Supply Petty Officer will necessitate the passing of a full examination as laid down in C.O.R., Article 198. Should an Acting Supply Petty Officer (Tempv.) desire to qualify for permanent advancement, he will be required to pass a professional paper in that section of the Supply Branch in which he has not already passed.

6. It is anticipated that the advancements in each section will be proportionately the same. It is intended as far as practicable to allocate to Destroyers, Frigates, &c., two Leading Supply Assistants or Supply Petty Officers, one Victualling and one Naval Stores, each of whom will be responsible to his Officer-in-Charge for his own section. It will be necessary for them to act for each other during short periods of leave or other absence.

7. Navy Order 451 of 1942 is cancelled.

(349/19/119.)

588.

SPECIAL ADVANCEMENTS OF OUTSTANDING MEN IN SEAGOING SHIPS.

It has been decided to institute a system of special advancement for outstanding men in Sea-going Ships.

2. The number of special advancements made will not, in normal circumstances, exceed a total of four per year for the R.A.N. and mobilized members of the Reserves combined.

3. These advancements will be in excess of the authorized establishment and will not interfere with normal roster advancements.

4. Returns of personnel recommended under this Order are to be forwarded by the Commanding Officers of Sea-going Ships so as to reach the Secretary, Naval Board, by 1st November and 1st May each year, "Nil" returns being furnished as necessary.

5. (i) Advancements will date from 1st January and 1st July following the receipt in Navy Office of recommendations, and ratings will be considered for advancement only on the first half-yearly occasion following receipt of recommendations. Ratings not selected for special advancement, if still considered deserving of such advancement, should be included in subsequent returns. Recommendations received after 1st November or 1st May will not be considered for the 1st January or 1st July selections respectively but will be regarded as recommendations for the following half-yearly selection.

(ii) In the event of a Commanding Officer considering that his recommendation for the special advancement of any rating should be withdrawn, a signal withdrawing the recommendation is to be despatched immediately and full details of his reasons for such action are to be forwarded by letter.

6. The first advancements under this Order will be made on 1st January, 1945, and, for this occasion, recommendations, which may be signalled, received up to 30th November, 1944, will be considered.

7. No advancement under this Order is to be made without the approval of the Naval Board.

(349/63/1653.)

(This Order will be reprinted for posting on Notice Boards.)

589.

GOOD CONDUCT BADGES—COUNTING OF PREVIOUS SERVICE TOWARDS AWARD.

Examination in Navy Office of applications to count previous Navy, Army or Air Force Service towards the award of Good Conduct Badges has revealed that ratings are to a large extent not aware of the conditions governing the counting of such time.

2. The general conditions of K.R. & A.I., Articles 530 to 533 (inclusive), apply in the R.A.N. with the following exceptions:—

(a) R.A.F.R. and "Hostilities Only" ratings may count all previous service irrespective of the break in service.

(b) Time served over the age of eighteen under training in Citizen Military Forces of the Commonwealth (including the three months' camp training enforced after the outbreak of the present war) and unmobilized service in the R.A.N.R., R.A.N.V.R., R.N.V.R., &c., is not allowed to count.

3. Commanding Officers of H.M.A. Ships and Establishments are to forward applications to count previous service, together with certified copies of discharge certificates, to the Director of Navy Accounts who will notify whether or not such service may count.

(448/201/1875.)

(This Order will be reprinted for posting on Notice Boards.)

590.

**A.M.S. VESSELS FITTED WITH BROWN TYPE "A" GYRO COMPASS
—REPLACEMENT OF 2 mfd. CONDENSERS IN TRANSMITTER
SPARK QUENCH CIRCUIT.**

The 2 mfd. condensers fitted in the transmitter spark-quenching circuit of Brown type "A" Gyro Compass were recently replaced in an A.M.S. Vessel by 80 mfd. condensers. After extensive trials the vessel reported that the repeaters worked satisfactorily and efficiently with this modification, and it has been decided that 80 mfd. condensers are to be fitted in all A.M.S. vessels with Brown Gyro Compass equipments.

2. Ships concerned are to forward demands for the necessary equipment and the work is to be carried out by Ship's Staff at the first available opportunity.

(603/279/907.)

591.

8-IN SHELL GRABS—"SCREW DOWN" TYPE.

An accident, involving injury to personnel, has occurred when an 8-in. shell was dropped from the grab during ammunitioning.

2. Care is to be taken that shell grabs are fully screwed down before shell is lifted.

3. Examination of shell grabs is to be carried out in accordance with B.R. 292, Chapter VIII, paragraph 353.

(524/204/328.)

592.

4-IN. MARK XXIII AND XXIII* GUN MOUNTINGS.

Navy Order 208 of 1944, Item 1, is to be amended to read as follows:—

1. *Spring Case Front Cap*—Hole for access to Drain Plug to be opened out to 1.25 inches diameter.

(490/203/1183.)

593.

GUNS AND MOUNTINGS—20 M.M. OERLIKON.

With reference to Admiralty Fleet Order 1413/43, Part IV, paragraph 10, when firing Oerlikon guns in hot climates, it is possible that barrel heat sufficient to ignite the propellant may occur before 240 rounds have been fired in rapid succession and consequently under these conditions it may be necessary to apply the precautions required by paragraph 14 after a lesser number of rounds.

(408/206/1427.)

594.

**BRIGHT STEEL BOLTS, NUTS AND STUDS MANUFACTURED FROM
MARBRITE FREE CUTTING STEEL.**

Quantities of Bolts, Nuts and Studs recently manufactured in Australia from Marbrite Free Cutting Steel are now held in Naval Store Depots and are not suitable for the purpose for which Bright Steel Bolts and Nuts to Admiralty Specification 92/1936 are used.

2. Arrangements have been made for these Bolts, Nuts and Studs to be treated by dipping into a fast dry black coating material to distinguish them from Bright Steel Bolts, Nuts and Studs. They are to be issued as Black Bolts, Nuts and Studs and are not to be used for machinery purposes.

(532/202/176.)

595.

**MUSTER OF BINOCULARS, TELESCOPES, WATCHES AND
HELIOGRAPHS.**

The attention of all concerned is drawn to Navy Order 397 of 1944, and to the necessity for early rendition to Navy Office of all outstanding reports in regard to the muster of binoculars, telescopes, watches and heliographs held in H.M.A. Ships and Establishments.

(670/201/883.)

596.

RESPIRATORS ANTI-GAS (LIGHT TYPE).

The provisions of Admiralty Fleet Orders 2629/43 and 652/44 regarding supply to Naval Combined Operations and Landing Craft Personnel of light type respirators in replacement of general service type will not apply in the Royal Australian Navy.

(669/201/1023.)

597.

R.A.N. WOMEN'S SERVICES—CALCULATION OF TIME.

The definitions of the terms "month", "year", &c., in K.R. and A.I., Explanation of Terms, as amended by K.R. 2/42, should be applied to calculations affecting pay, advancement, seniority, &c., of members of the R.A.N. Women's Services in the same way as they are applied for such purposes to R.A.N. personnel.

(432/224/2956.)

598.

COUNTERPANES, COVERLETS AND MATTRESS COVERS—RETURN TO STORE OF NUMBERS HELD IN EXCESS OF ALLOWANCES.

In view of the necessity for economy and for conserving supplies of textile materials, the allowances of counterpanes, coverlets, and mattress covers as revised by A.F.O. 6071/42 are re-promulgated for information:—

- (a) *Counterpanes, Pattern 295.* Allowance reduced forthwith from two to one for each officer, plus 10 per cent. spare. When stocks are expended, one coverlet, pattern 25, to be allowed in lieu, plus 10 per cent. spare. No further purchases of counterpanes will be made.
- (b) *Coverlets, Pattern 25.* See (a) above. The allowance to sick bays remains unaltered.
- (c) *Mattress Covers.* To be reduced from two to one for each mattress, Pattern 21, 399, T.372, T.373 and T.374, plus 50 per cent. spare.

2. It should be observed, however, that neither coverlets nor counterpanes are allowed to W.R.A.N.S. Officers and Ratings, *vide* Navy Order 169 of 1944.

3. Ships and Establishments should return to the nearest Naval Store Depot, counterpanes, coverlets and mattress covers held in excess of the above allowances.

(612/235/936.)

599.

AUSTRALIAN ARMY CANTEENS SERVICE ISSUING POINTS.

Advice has been received that Australian Army Canteens Service Issuing Points at Rockhampton and Jacky Jacky (Red Island Point) have been closed.

2. The Appendix to Navy Order 484 of 1944 is to be amended accordingly.

(427/201/828.)

600.

B.R. AND O.U. BOOKS ACCOUNT.

It has come under notice that lists of errata and addenda to publications have been taken on charge in the B.R. and O.U. Books Account of H.M.A. Ships.

2. Lists of Errata and Supplements to main publications and Addenda (unless issued as a separate bound and numbered volume) need not be accounted for, and should not, in future, be taken on ledger charge.

3. The instruction in regard to accounting for these and similar papers is laid down in B.R. 1, paragraph 15, of which the following is an extract:—

Paragraph 15 (c). "Post Office and Railway Guides, and Navy, Army and Royal Air Force Lists, Lists of Errata and Supplements to main publications and Addenda (unless issued as a separate bound and numbered volume) need not be accounted for."

(571/201/4422.)

601.

FORM S.102 AND S.103—RECORDS OF ISSUE AND RETURN OF LOAN CLOTHING

The above-mentioned forms have been adopted for use in the R.A.N. and the first supply will be distributed, without demand, by the Superintending Naval Store Officer, Sydney, to each H.M.A. Ship and Naval Depot.

2. The forms are to be brought into operation immediately upon receipt in accordance with instructions shown in the forms.

3. Form S.101 Size 2 is to be used in all Shore Establishments, A.M.S. Vessels and larger ships, and Form S.103 (Loose Leaf) utilized for M.Ls., H.M.A. Auxiliaries and similar small ships.

(A.F.O. 5906/43.)
(480/202/4580.)

602.

BOOKS AND FORMS.

First supplies of the under-mentioned publications have been distributed:—

B.R.105/43.—"Merchant Ships" by Talbot Booth.

(571/202/1696.)

B.R.287/ (1).—Addendum No. 1 to B.R. 287. Turret Gun Drill for 5.25-inch Q.F. Guns, Mark I, on Twin HA/LA, Mark II Mountings, for Mountings fitted with R.P. 10 system of Remote Power Control.

(A.F.O. 1274/44.)
(571/202/1544.)

B.R.114/43.—Treatment of Open Head Injuries.

(A.F.O. 758/44.)
(571/202/1924.)

B.R.812/43.—Drill for 40 m.m. Gun, Mark IV on Twin Mark IV Mounting.

(A.F.O. 2898/43.)
(571/202/1763.)

B.R.851.—Medical Research Council War Memorandum No. 11
—“Control of Cross Infection in Hospital Wards.”

(A.F.O. 3350/43.)
(571/202/1797.)

B.R.358.—Interservice Instructions for Ground/Air Recognition
and Identification.

(A.F.O. 6172/43.)
(571/202/1941.)

B.R.863.—Royal Naval Air Station Magazine and Explosives
Regulations.

(A.F.O. 1736/44.)
(571/202/1963.)

B.R.869 (4) (supersedes B.R.300).—Instructions for the use
of the A.A. Verifying Camera, 1944.

(A.F.O. 363/44.)
(571/202/1917.)

B.R.980κ.—Range Table No. 571 for Q.F. 4-in. Guns, Mark IV,
and Range Table No. 572 for Q.F. 4-in. Gun, Mark V,
dated January, 1944.

(A.F.O. 3596/44.)
(571/202/1897.)

B.R.980 (K), (X), and (G).—Trajectory Chart O.B., Diagram
No. 119, dated February, 1944, for Q.F., 4-in. Guns,
Marks V and XVI, Q.F., 4.5-in. Guns, Marks I, III, and
IV, Q.F., 5.25-in., Mark I, Guns.

(A.F.O. 2405/44.)
(571/202/1897.)

B.R.985.—Handbook and Drill for the Haszard R.M. Type Semi-
Mobile 20 m.m. Oerlikon Mounting.

(A.F.O. 362/44.)
(571/202/1916.)

B.R.996.—Small Ships' Basic Code.

(A.F.O. 1428/44.)
(571/202/1973.)

B.R.1005/43 (supersedes O.U.5504 and 5504 (1)).—Regulations
for Maintenance of 21-in. Mks. IX*-IX** and IX**
N.A.B. Torpedoes.

(A.F.O. 761/44.)
(571/202/1923.)

B.R.'s 1011 and 1012.—Wartime Instructions to Merchant Ships,
Volumes I and III.

(571/202/1992.)

B.R.1026/44.—Notes for the Guidance of D.G. Inspecting
Officers.

(A.F.O. 762/44.)
(571/202/1920.)

B.R.1041.—Equipment of Naval Stores for Defensively-equipped
Merchant Ships and Staffs of the Naval Control Service.

(A.F.O. 1738/44.)
(571/202/1961.)

B.R.1073/44.—Medical Research Council War Memorandum,
No. 12—“The Use of Penicillin in Treating War Wounds.”

(A.F.O. 2536/44.)
(571/202/2006.)

Errata No. 14 to O.U.5365A.—Priced Vocabulary of Naval
Armament Stores—Part I.

Errata No. 29 to O.U.5365B.—Priced Vocabulary of Naval
Armament Stores—Part II.

Errata No. 14 to O.U.5365C.—Priced Vocabulary of Naval
Armament Stores—Part III.

(A.F.O. 2016/44.)
(571/203/2495.)

Errata No. 4 to O.U.5420.—Victualling Rate Book.

(A.F.O. 2686/44.)
(571/203/2449.)

O.U.6353.—British Merchant Ships lost—January, February,
March, and April, Supplements.

O.U.6353A.—Foreign Merchant Ships lost and damaged by
the Enemy—January, February, March, and April,
Supplements.

(A.F.O.'s. 2016, 2686, and 3891/44.)
(571/203/2460.)

A.P.1976.—Amendment Lists, Nos. 55 and 56—Performance
Tables of Foreign Service Aircraft.

(A.F.O. 2686/44.)
(571/201/3731.)

Memoranda on Medical Diseases in Tropical and Sub-Tropical
Areas, 1942—Reprinted May, 1943, incorporating Amend-
ment No. 1.

(A.F.O. 364/44.)
(571/201/4134.)

Army Training Memorandum (War) (Australia), No. 35.

(546/201/443.)

2. The under-mentioned forms have been introduced for use in the R.A.N. in lieu of the corresponding Admiralty forms. Supply will be effected, on demand, by the Superintending Naval Store Officer, Sydney, when stock of the existing forms is exhausted:—

A.T.206.—Embarkation Return.

A.T.207.—Disembarkation Return.

(480/201/3418.)

3. The under-mentioned form has been revised and first supply will be effected, without demand, by the Superintending Naval Store Officer, Sydney. All copies of the superseded form should be returned to store as opportunity occurs:—

A.S.330.—Report of Survey on Provisions or other Victualling Stores damaged, defective, or decayed.

(480/202/4608.)

4. The under-mentioned form has been adopted for use in the R.A.N. First supply will be made, without demand, by the Superintending Naval Store Officer, Sydney.

S.1174.—Log Book for Cinema Projector Accessories and Films.

(A.F.O. 1611/42.)

(480/202/4536.)

603.

LUBRICATING OILS AND GREASES—STANDARDIZATION AND PURCHASE.

The list of Proprietary Brands of Lubricating Oils shown in Appendix "A" of Navy Order 639 of 1943 is to be amended as follows:—

Delete Vacuum Filtered Cylinder Oil.—Insert Wakefield Filtered Cylinder Oil.

Delete Vacuum 600 S.—Insert Wakefield 600 S Cylinder Oil.

Delete Vacuum Perfect.—Insert Wakefield Perfect.

Delete Vacuum Medium.—Insert Wakefield Medium.

Delete Vacuum C.C. Medium (Amber).—Insert Wakefield C.C. Medium (Amber) Oil.

Delete Vacuum Gargoyle D.T.E.—Insert Vacuum Gargoyle D.T.E. B.B.

Delete Vacuum BB.—Insert Vacuum Gargoyle D.T.E. B.B.

Delete Caltex Teresso 85.—Insert Atlantic Teresso 85.

(545/201/496.)

604.

LONDON CORRESPONDENCE.

The Naval Liaison Officer, London, has reported that correspondence from Australia addressed "Accountant Officer, H.M.A. London Depot, care of G.P.O." is liable to be misdirected or delayed on arrival in London.

2. Correspondence for H.M.A. Naval Depot and H.M.A.S. *Cerberus II* should, therefore, be addressed—

H.M.A. Naval Depot,
Australia House,
Strand,
London, W.C.2.

(443/201/1401.)

605.

FOOD COUPONS—NAVAL PERSONNEL.

The following amendments are to be made to Navy Order 266 of 1944:—

(1) *Paragraph 5.*—Add to sub-paragraph 1—

"When Issues are made for periods of two weeks or more, one butter half-coupon is to be excised, or cancelled in ink or indelible stamp, for each two weeks' entitlement. Periods of less than two weeks are to be disregarded. Monthly returns of coupon transactions are to include a certificate that such action has been taken."

(A.I.G. 103/021239/June.)

(350/201/76.)

(2) *Paragraph 6.*—

(a) After the word "ships" in line 2 insert the words "also to personnel appropriated to Naval Establishments from sea-going ships or advanced areas."

(b) Delete all words commencing with "This special concession" to the end of the paragraph.

(A.I.G. 103/262029/October.)

(350/201/66.)

606.

WAR COMFORTS FORWARDED TO H.M.A. SHIPS AND ESTABLISHMENTS—ACKNOWLEDGMENT OF.

Examination of records at Navy Office and reports from various sources indicate that the provisions of Navy Order 525 of 1943, paragraph 5 (iii), regarding the forwarding of acknowledgments direct to donors of war comforts, are frequently not complied with and the attention of Commanding Officers is drawn to the apparent oversight in this respect when the source of supply is known or can be readily ascertained.

(552/201/1192.)

RESTRICTED.(FOR OFFICIAL USE ONLY.)

Commonwealth Navy Orders.

Navy Office, Melbourne,

21st November, 1944.

The following Orders, having been approved, are hereby promulgated for information and guidance, and necessary action.

By direction of the Naval Board,

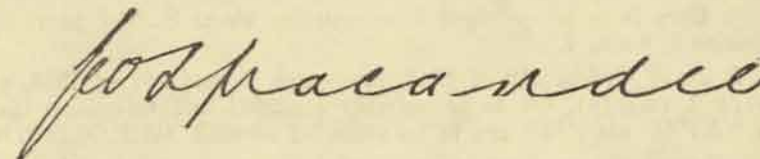

Secretary.

*The Commodore Commanding H.M.A. Squadron,
and Commanding Officers of H.M.A. Ships,
Officers in Charge of H.M.A. Naval
Establishments, and others concerned.*

TABLE OF CONTENTS.

No.	Subject.
607.	Grant of Acting Rank or Relative Rank of Lieutenant-Commander—Naval Reserves.
608.	Release of Naval Personnel.
609.	Navy, Army and Air Force Club of Victoria—Honorary Membership.
610.	4-in. Mk. XXIII and XXIII* Mountings—Care in Assembly of Roller Units.
611.	Machine Tools—Co-ordinated Use in Australia Between the Services.
612.	Naval Armament and Torpedo Store Accounts—Errors and Omissions, &c.
613.	Naval Armament Stores in D.E.M.S.—Accounting Procedure.
614.	Rifles Aiming 1-in. Elswick "A"—Supply for use in 4-in. Mark XIX Guns Fitted in H.M.A. Ships.
615.	Broadcast Receivers—Commercial Types.
616.	Books and Forms.
617.	Victualling Arrangements—Christmas Day, 1944.
618.	Administration of Service System Canteens in H.M.A. Ships and Naval Establishments where an Accountant Officer is Not Borne.

607.

**GRANT OF ACTING RANK OR RELATIVE RANK OF
LIEUTENANT-COMMANDER—NAVAL RESERVES.**

Attention is directed to A.F.O. 3927/44 which consolidates the previous Orders governing the half-yearly selective promotion of officers to Acting Lieutenant-Commander in the R.N.

2. All officers who are eligible and suitable for consideration under the provisions of A.F.O. 3927/44, are to be reported upon half-yearly whether they are recommended for promotion or not, including those who have been granted the rank or relative rank of Acting Lieutenant-Commander "whilst serving in their present appointment".

3. Where more than twenty eligible officers are borne in any one ship or establishment, Form S.206d need only be forwarded for those who are recommended for ACCELERATED or IMMEDIATE promotion, but the names of all officers in the zone must appear on covering Form S.596 whether they are recommended or not. Separate Forms S.596 are to be used for R.A.N.R.(S), R.A.N.R. and R.A.N.V.R., respectively.

4. Care is to be exercised in completing Form S.206d, particularly sections 5, 6 and 7.

5. Navy Orders 359 of 1943, paragraph 3, and 257 of 1944, paragraph 1 (ii) (e), are to be suitably amended and references therein to "A.F.O. 4240/42" are to be amended to read "A.F.O. 3927/44".

(432/205/5567.)

608.

RELEASE OF NAVAL PERSONNEL.

It has been brought to notice that the Deputy Director-General of Man Power in one of the States has recently suffered embarrassment through the contents of reports made by his Officers on the application of a rating for release being conveyed to the rating concerned.

2. In future, information received from the Man Power Authorities is *not* to be conveyed to any member applying for release. Where Man Power have seen fit to reject an application, the applicant is to be informed that the application has not been recommended by Man Power.

(451/201/127.)

609.

**NAVY, ARMY AND AIR FORCE CLUB OF VICTORIA—HONORARY
MEMBERSHIP.**

The increased restrictions brought about by the war have made it necessary to restrict the privileges of Honorary Membership of the Navy, Army and Air Force Club of Victoria to those officers who are members of affiliated Clubs.

2. The following are affiliated Clubs:—

Imperial Service Club, Sydney.

United Services Club, Brisbane.

Naval and Military Club, Hobart.

Naval, Military and Air Force Club, Adelaide.

Naval, Military and Air Force Club, Perth.

3. Navy Order 105 of 1942 is cancelled.

(462/201/2316.)

610.

**4-IN. MK. XXIII AND XXIII* MOUNTINGS—CARE IN ASSEMBLY
OF ROLLER UNITS.**

Instances have been reported where the elastic training roller units have been assembled in the Mounting incorrectly.

2. After stripping roller units, every care should be taken to ensure that the rollers are assembled in the correct direction to revolve when the mounting is trained.

3. After the removal of a roller unit, training efforts should be taken to check that the assembly has been carried out correctly.

4. The attention of all ratings employed in the maintenance of gunnery material should be called to this Order.

(490/203/1240.)

611.

**MACHINE TOOLS—CO-ORDINATED USE IN AUSTRALIA BETWEEN
THE SERVICES.**

The shortage of machine tools in Australia can be alleviated, to some extent, by pooling existing workshop facilities wherever possible. This applies particularly to static workshops equipped with heavy and expensive machine tools such as crankshaft grinders, milling and shaping machines, special lathes and the like. It is in the national interest that such machine tools be fully employed at all times, and this can only be achieved by active co-operation between all Service workshops located in an area.

2. A survey has been made of heavy machine tool facilities of workshops operated by all Services in Northern Queensland, Northern Territory, Central Australia and Western Australia and details are shown in the attached Appendices "A", "B" and "C". The question of co-ordinating all workshop facilities in these areas has been discussed between the Headquarters of all Services concerned and it was agreed that separate instructions would be issued by each authority to put this scheme into effect forthwith.

3. All Naval Officers-in-Charge are to make full use of these workshop facilities listed in Appendices "A", "B" and "C", whenever possible, and are to undertake machine shop work for other Services, provided that it does not interfere with normal Naval repairs. Negotiations for such reciprocal work are to be made locally between Officers-in-Charge of workshops. The usual requisitions for services and materials will be required, but, normally, there should be no financial or other transaction. Wherever possible, the Requisitioning Authority is to provide the necessary raw materials.

4. Monthly returns are to be forwarded to the Naval Board by the Naval Officers-in-Charge concerned, showing the amount and class of reciprocal work carried out in accordance with this Order, both for and by other Services.

Returns are to reach Navy Office not later than two weeks after the end of the month under review. Nil returns are to be submitted when applicable.

APPENDIX "A".

PRINCIPAL WORKSHOPS OPERATED BY THE SERVICES IN NORTHERN QUEENSLAND WITH BRIEF DETAILS OF MACHINE TOOLS INSTALLED.

Bredden—No. 13 Aircraft Repair Depot, R.A.A.F.

Hammer, pneumatic, power, 2-cwt.
Machine, drilling, radial, No. 4 morse taper.
Machine, grinding, Universal, 12-in. x 50-in. "Churchill".
Machine, milling, Universal, "Cincinatti" No. 2.
Machine, woodworking, bandsaw 36-in.
Lathe, 13-in. Oldfield and Schofield (5 ft. 6 in. between centres, 44-in. x 12-in. gap).

Cairns—Cairns Area Workshop, Australian Electrical Mechanical Engineers.

Lathe, 8-in. short bed.
Plant, welding, electric, transformer type, 7KVA.

Cairns—Naval Base.

Lathe, all geared head, "Covmac".
Lathe, precision cabinet, 3½-in. centre, "Wickman".
Machine, boring, OPG No. 2, "Kearns".
Machine, shaping, 18-in. "Ormerod" type.
Machine, milling, "Cincinatti" No. 3.
Machine, drilling, radial 3-ft. "Town".
Lathe, wood turning, "Premo".
Lathe, engine, "Simmons" (Swing 18-in. over ways—27-in. with gap removed—10-ft. bed).
Lathe, 8½-in. "Holvic".
Lathe, 4½-in. "Hercus".
Plant, welding, 260 amp. "Quasi-Arc".
Press, hydraulic, 60-ton, with test centre attachment.
Machine, woodworking—Plain, saw bench, 32-in.
Machine, woodworking—Planer, panel, 24-in.
Machine, woodworking—Bandsaw, 36-in.

Charters Towers—No. 9 Australian Advanced Workshop, Australian Electrical and Mechanical Engineers.

Furnace heat treatment, oil fired.
Lathe, 4½-in. semi-precision.
Lathe, 5-in. (two).
Lathe, 6-in. "Selson".
Lathe, 6-in. "Mars" (two).
Lathe, 7½-in., long bed.
Lathe, 8-in., short bed (two).
Lathe, 8½-in. short bed.
Press, hydraulic, 10-tons.
Press, hydraulic, 60-tons (three).
Machine, woodworking—
Lathe, wood turning, 6-in.
Bandsaw, 32-in.
Saw Bench, 30-in. (two).
Planer and thicknesser, 16-in. x 20-in.

Machine, drilling, pillar 1½-in. (two).
Machine, drilling, radial, 36-in.
Machine, grinding crankshaft, 48-in., "Landis".
Machine, grinding Piston with cam attachment.
Machine, grinding, Universal.
Machine, milling, Universal.
Machine, shaping, 14-in. x 18-in.

Tolga—No. 3 Australian Advanced Workshop, Australian Electrical and Mechanical Engineers.

Lathe, 7½-in. centre, long bed.
Lathe, 8-in., short bed.
Lathe, 8½-in., short bed.
Lathe, 10½-in. turret.
Lathe, 6-in., wood turning.
Machine, boring cylinder, electric No. 1.

APPENDIX "B".

PRINCIPAL WORKSHOPS OPERATED BY THE SERVICES IN NORTHERN TERRITORY AND CENTRAL AUSTRALIA WITH BRIEF DETAILS OF MACHINE TOOLS INSTALLED.

Alice Springs—No. 2 Australian Motor Transport Workshop, Australian Electrical and Mechanical Engineers.

Machines, boring cylinder (three).
Plants, welding, electric, engine driven—150 amp. (two).
Machine, metal working, multi-purpose.
Machines, remetalting and boring bearings (three).
Machines, grinding crankshaft, "Landis", 16-in. x 48-in.
Lathe, 7-in. short bed.
Lathe, 7½-in. long bed.
Lathe, 8-in. short bed.
Lathe, 8½-in. short bed.
Lathe, brake drum truing.
Machine, piston finishing.
Machine, shaping 7-in.

Birdum—No. 14 Aircraft Repair Depot, R.A.A.F.

Machine, drilling radial, No. 3 morse taper "Archdale".
 Machine, grinding, Universal 12-in. x 50-in. "Churchill".
 Machine, milling, Universal, "Kerbes" (equivalent to No. 2 "Cincinatti").
 Hammer, pneumatic, 2-cwt.
 Machine, woodworking, bandsaw, 36-in.
 Machine, spot welding, capacity 3/16-in. steel (14 gauge aluminium, length of throat 2-ft.).

Darwin—Naval Base.

Lathe, 9-in. swing, "Hercus" (two).
 Lathe, sliding, surfacing and screw-cutting, "Herbert Nuttall" (two).
 Lathe, sliding, surfacing and screw-cutting, 20-in. "Lang".
 Lathe, light helical, "Macson" type (12½-in. centre—15 ft. 9 in. between centres).
 Lathe, 6½-in. "Herbert Nuttall" (two).
 Lathe, precision, "South Bend" (two).
 Lathe, 8-in. centre, "Holvic".
 Machine, drilling radial, "Town".
 Machine, milling, "Kearney and Trecker" No. 2H plain type.
 Machine, punching and shearing, ¾-in.
 Rolls, plate, to take 6-ft. x ½-in. steel plates.
 Machine, drilling radial, "Carlton" type 1A (4-ft. arm—11-in. column).
 Machine, planing, 8-ft. x 3-ft. x 3-ft. "Summerskill" type.
 Hammer, pneumatic, 5-cwt.
 Machine, slotting, 16-in. "Ormerod".
 Press, hydraulic, 60-tons, with test centre equipment.
 Machine, drilling, 3-ft. 6-in. "Kitchen and Wade".
 Machine, boring, milling and drilling, horizontal, "Giddings and Lewis".
 Machine, shaping, 18-in. "Macson".
 Machine, woodworking—
 Lathe, woodturning 9-in. centre, 5-ft. bed.
 Lathe, woodturning 6-in. centre, 6-ft. bed.
 Saw bench, fixed table, 32-in.
 Planer and thicknesser, 24-in. "Macson Barker".
 Planer and thicknesser, 24-in. "TA" type.
 Bandsaw, 36-in. "Macson Barker".
 Saw Bench, steel frame, rip and crosscut.
 Jointer, 12-in.

Darwin—Fortress Workshop, Australian Electrical and Mechanical Engineers.

Lathe, 4½-in.
 Lathe, 8-in. short bed.
 Machine, milling, Universal.
 Plant, welding, electric, engine driven 150 amp.
 Machine, shaping, 18-in.
 Machine, drilling radial.

APPENDIX "C".

PRINCIPAL WORKSHOPS OPERATED BY THE SERVICES
IN WESTERN AUSTRALIA WITH BRIEF DETAILS OF
MACHINE TOOLS INSTALLED.*Nungarin—No. 5 Australian Base Workshop, Australian Electrical and Mechanical Engineers.*

Lathe, 3½-in. precision (three).
 Lathe, 4½-in. semi-precision (five).
 Lathe, 5-in.
 Lathe, 7½-in. long bed (three).
 Lathe, 8½-in. short bed (two).
 Machine, drilling, electric pillar 1¼-in. (three).
 Machine, drilling, radial, 36-in. (two).
 Machine, grinding crankshaft 72-in. "Norton".
 Machine, grinding cylinder, horizontal, "Heald".
 Machine, milling, Universal, No. 2.
 Machine, hydro honing, "Micromatic" vertical.
 Machine, boring and honing line, "Barnes 306C".
 Machine, boring line "Tobin-Arp".
 Machine woodworking—
 Bandsaw 32-in. (two).
 Saw Bench 30-in. (two).
 Planer and thicknesser 16-in. x 20-in.
 Hammer, power.
 Press, hydraulic 60-tons (four).

Fremantle—Naval Base.

Lathe, sliding, surfacing and screwcutting, 8-in. "New Visby".
 Lathe, 7½-in. x 7-ft. "Willson".
 Lathe, sliding, surfacing and screwcutting, 8½-in. centres, 6-ft. bed "Macson".
 Lathe, 9-in. swing "Hercus" (three).
 Lathe, 10-in. x 16-in. "Atlas" TH36.
 Lathe, bench, 4-in. x 15-in. "Stedall".
 Lathe, screwcutting "Atlas".
 Lathe, 8-in. "New Visby".
 Lathe, 6½-in. "Herbert Nuttall" (two).
 Lathe, 16-in. x 8-in. D. and M. Economy.
 Machine, milling, Universal, "Kearney and Trecker" No. 2K.
 Machine, milling, Universal, Ram type, "Van Norman".
 Machine, shaping, 18-in. (two).
 Machine, shaping, crank high speed, "Hendley".
 Machine, drilling radial 3-ft. "Town".
 Machine, drilling 1¼-in. "Hercus" No. 4 (three).
 Machine, drilling 1/4 box column "Barnesdril" No. 201.
 Machine, drilling upright 3/4-in. x 17-in. swing "Macson".
 Machine, woodworking—
 Lathe, woodturning 6-in. centre, 6-ft. bed.
 Saw bench, 20-in. "Macson-Barker".
 Saw bench, 36-in. (two).
 Bandsaw, 32-in. "Macson-Barker" (three).
 Bandsaw, 32-in.
 Planer and thicknesser, 20-in. "Macson-Barker".
 Thicknesser, "Ransome".
 Multi-purpose, "Universal" (two).
 Press hydraulic, 60-ton.

612.

**NAVAL ARMAMENT AND TORPEDO STORE ACCOUNTS—
ERRORS, OMISSIONS, ETC.**

During the war period, several relaxations in Naval Armament Store Accounting have been authorized, and the accounts now required do not call for an undue amount of paper work on the part of store-keeping officers. Nevertheless, too great a proportion of Naval Armament and Torpedo Store Accounts continues to be received in office in an unsatisfactory state.

2. Failure to render an account at all is far too common an omission, especially on the part of small ships. This causes a great amount of avoidable correspondence. Clear instructions as to when accounts are to be closed are contained in the introductory pages of the ledger. In the case of small ships using form F.A.30, attention is drawn to the fact that accounts are to be closed (a) biennially, or (b) on change of accounting officer, or (c) on paying off, i.e., closed after a maximum period of 2 years unless earlier closure is necessitated by (b) or (c). All accounts are to be forwarded by registered post to the Secretary, Naval Board, Victoria Barracks, Melbourne, accompanied by all supporting vouchers.

3. Many ledgers received bear evidence that they have been hastily compiled only when the account was due to be closed. Obviously, accurate storekeeping is impossible in such circumstances, and the accounting officer has no ready means of ascertaining shortages in his authorized establishment of stores.

4. Attention is drawn to the necessity for the out-going officer to close his account before he leaves his ship. The instructions in King's Regulations and Admiralty Instructions, Article 1959, clause 7, are always to be complied with, and the completed accounts are to be handed to the Commanding Officer by the out-going officer. The fact that arrangements may have been made for the out-going officer to take up his new appointment on a certain date, and that the change-over to the new accounting officer has not taken place by that date, is not considered by the Naval Board to be sufficient reason for the abrogation of the instructions contained in that clause.

5. The attention of Commanding Officers is drawn to their responsibility with regard to the rendition of Store Accounts on the due dates, and that they are complete in all respects and signed by the proper officers, as laid down in King's Regulations and Admiralty Instructions, Article 856.

6. The following are common errors noted in the examination of Naval Armament Store Accounts on Form F.A. 30:—

- (i) Incorrect quantities brought forward from the preceding account. Where the quantities of stores actually found at stocktaking agree with the "remains" of the account to be closed, the quantities brought forward in the new account must agree with the remains as shown. In other cases, the quantities actually found at stocktaking are to be brought forward in the new account, and the items found deficient or surplus are to be posted on lines 42 and 43 of the old account and recorded on the Report of Stocktaking at the end of the ledger with explanations of the differences.

- (ii) Issues and receipts posted into the ledger disagree as to quantity with the supporting vouchers.
- (iii) Omission to forward with the account all the issue and receipt vouchers covering transactions posted in the ledger.
- (iv) Failure to keep a record on the appropriate pages at the end of the ledger of all expenditure of ammunition, spare parts of guns, &c., and to write off charge on lines 17 to 26 the articles so expended, including "S" items.
- (v) Failure to keep a record of Exceptional Expenditure and Accidental Losses on the page provided for that purpose at the end of the ledger and to write off charge such expenditure.

7. Accounting Officers are to make themselves thoroughly conversant and comply strictly with the clear and precise instructions contained in the introductory section of the ledger.

8. Navy Orders 116 of 1940, 235 of 1941, 140 and 385 of 1942 and 355 of 1943 are cancelled.

(614/210/19.)

613.

NAVAL ARMAMENT STORES IN D.E.M.S.—ACCOUNTING PROCEDURE.

With reference to Navy Order 315 of 1944, paragraph 1, for "Admiralty Fleet Order 503/43" read "Admiralty Fleet Order 503/44".

(612/204/1523.)

614.

**RIFLES AIMING 1-IN. ELSWICK "A"—SUPPLY FOR USE IN 4-IN.
MARK XIX GUNS FITTED IN H.M.A. SHIPS.**

To improve the facilities for gunnery training in H.M.A. Ships mounting 4-in. Mark XIX guns, and in view of the fact that 2 pdr. sub-calibre guns are not available for 4-in. guns of this mark, arrangements are being made for the conversion of a number of 1-in. aiming rifles for use in these guns.

2. The aiming rifles will be supplied without demand as indicated below, for use by ships based at, or visiting, the ports concerned:—

Naval Officer-in-Charge, Sydney	2
Naval Officer-in-Charge, Brisbane	1
Naval Officer-in-Charge, Cairns	2
Port Director, Milne Bay	1
Commander (D), Madang	3
Naval Officer-in-Charge, Darwin	2
Naval Officer-in-Charge, Fremantle	2
Naval Officer-in-Charge, Port Adelaide	1
Naval Officer-in-Charge, Port Melbourne	1
Naval Officer-in-Charge, Flinders Naval Depot	2
Naval Officer-in-Charge, Townsville	1

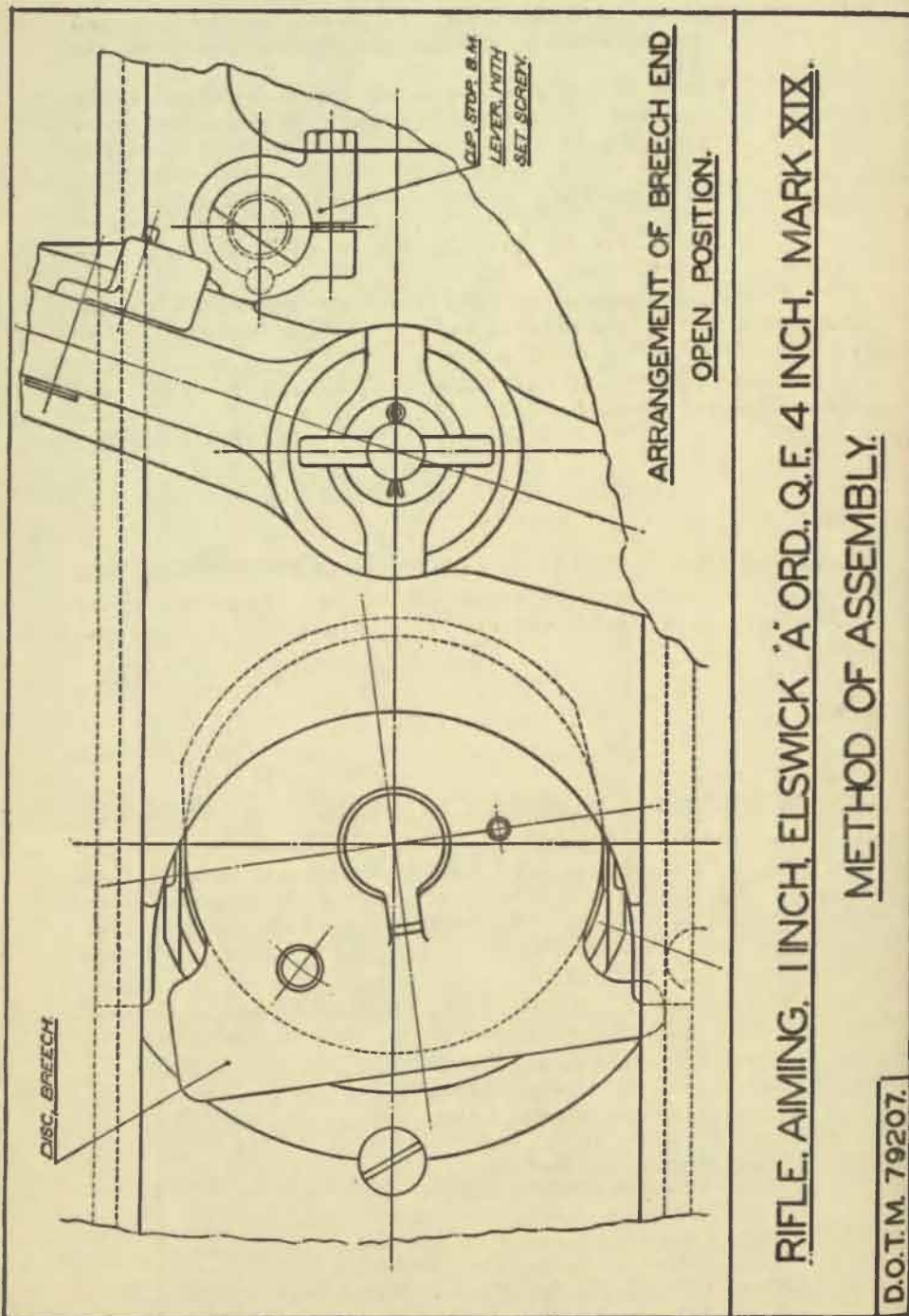

3. The following equipment will be supplied with each aiming rifle:—

- (i) A clip, stop, B.M. lever, which is used to prevent the breech opening too far and allowing the rifle to fall out of the parent gun. (See appended Drawing D.O.T.M. 79207 for method of assembly).
- (ii) Rod, cleaning and brush cleaning.
- (iii) Extractor cartridge.
- (iv) Extractor, barrel.
- (v) Wrench, aiming rifle.
- (vi) An initial supply of 500 rounds of ammunition.

4. The annual practice allowance of ammunition is to be 400 rounds *per parent gun*, i.e., each R.A.N. ship may fire 400 rounds per annum from each 4-in. Mark XIX. gun fitted.

5. One-inch aiming rifle ammunition is sometimes defective, and causes "puffrounds", the bullet lodging in the bore of the Aiming Rifle. A suitable stick is therefore to be thrust through the bore of the rifle after firing each round.

6. Before shipping the aiming rifle, the bore of the parent gun is to be thoroughly dried out, so that all traces of oil are removed. This is necessary as the carbon deposited in the bore of the parent gun is much more difficult to remove if oil is present in the bore.

7. It is most important that both the aiming rifle and the parent gun be thoroughly sponged out after firing. The plug bore gauge is always to be passed through the parent gun on completion of aiming rifle firing.

(412/202/399.)

615.

BROADCAST RECEIVERS—COMMERCIAL TYPES.

The attention of the Naval Board has been drawn to the use, on board H.M.A. Ships, of commercial types of Broadcast Receivers which may re-radiate, thereby rendering the ships liable to detection by enemy direction finding.

2. To ensure that no Receivers of these types are used, Commanding Officers are to satisfy themselves that the provisions of Commonwealth Notices to Mariners No. 127 of 1940 and No. 249 of 1940 are complied with.

3. No Broadcast Receiver is to be used in seagoing ships unless a certificate is obtained from the manufacturers or their agents that the radiation, when the Receiver is attached to an aerial suitable for receiving on any of the frequencies for which it is capable of being used, does not exceed 0.1 microvolts per metre when measured at a distance of one nautical mile.

4. Broadcast Receivers presented to H.M.A. Ships by the Australian Comforts Fund, through the medium of the Director of Naval Victualling, may be considered to comply with the above requirements.

(2037/4/195.)

616.

BOOKS AND FORMS.

H.M.A. ships fitted with Mark 14 Gyro Gun Sights are to return Hand Books O.D. 4429 in excess of 2 No. to the Superintending Naval Store Officer, Garden Island, Sydney, and all ships issued with Mark 14 Gyro Gun Sights for which no Hand Books are supplied are to demand up to 2 No. per ship from that officer.

2. Instructions regarding the return of Hand Books O.D. 4429 when defective sights are landed, contained in C.A.F.O. 1401/44, paragraphs 16, 93 and 94, will be amended.

(571/201/4381.)

617.

VICTUALLING ARRANGEMENTS—CHRISTMAS DAY, 1944.

The following arrangements relating to the victualling of Naval personnel on Christmas Day, 1944, are promulgated for general information in confirmation of A.I.G. signal No. 130809 November:—

- (a) *General Mess Ships and Establishments:* Additional expenditure incurred in the provision of special fare for personnel victualled in the general mess of H.M.A. Ships and Establishments is to be governed by the provisions of C.O.R., Article 451, paragraph 6 of which is to be specially noted.
- (b) *Naval personnel in receipt of Army Rations:* Arrangements have been made for Naval personnel in receipt of Army rations to receive supplementary rations, to the value of an additional one shilling per head, as provided for Army personnel.
- (c) *Personnel victualled on repayment:* Personnel victualled on repayment, whether ashore or afloat, are to be credited with an additional amount of one shilling per head on Christmas Day in Form A.S. 462Z for the purchase of special foodstuffs. This amount is additional to the victualling assistance provided in Navy Order 444 of 1944 for ships in Northern areas and to the normal victualling allowance in other areas, but will not apply to Officers' repayment messes in general mess Ships and Establishments.

(668/201/2929.)

618.

ADMINISTRATION OF SERVICE SYSTEM CANTEENS IN H.M.A. SHIPS AND NAVAL ESTABLISHMENTS WHERE AN ACCOUNTANT OFFICER IS NOT BORNE.

With reference to paragraph 2A (viii) of Navy Order 484 of 1944, the following modified instructions for the administration of the above-mentioned canteens are promulgated for information and strict observance:—

1. *Canteen Rules:* The Captain shall cause proper rules to be drawn up for the conduct and administration of the canteen.
2. *Canteen Committee:* The composition of the Canteen Committee is to be based, as far as the complement permits, on the general principles enumerated in K.R. and A.I., Article 630, clause 2, and the Executive Officer is always to act as ex-officio president.
3. *Duties of Canteen Committee:* Subject to 1 above and the provisions of Section A of Navy Order 484 of 1944, the Canteen Committee is responsible for the general administration of all matters relating to the canteen and for the administration of the Ship's Fund.
4. *Ship's Fund:* The profits of the canteen are to be paid to the Ship's Fund which is to be utilized and controlled as provided in K.R. and A.I., Article 630, Clause 4.
5. *Prices:* The prices of all goods sold in the canteen are to be regulated as provided in paragraph 2A (i) and (iv) of Navy Order 484 of 1944. A list of such authorized prices is to be displayed prominently in or near the canteen and all sales to individuals are to be on a cash basis.
6. *Canteen Attendants:* Canteen attendants may be paid such remuneration for their services as may be decided by the Canteen Committee and approved by the Captain.
7. *Periodical Audit of Accounts and Stocktaking:* The accounts of the canteen are to be audited and the stock checked by at least two representatives of the Committee detailed for the purpose by the Captain. These operations are to be carried out at the end of each quarter and at least on one other occasion during the quarter without notice. A record of such examinations is to be maintained and inspected by the Accountant Officer of the parent ship as opportunity offers.
8. *Custody of money:* (i) The Captain is to ensure that satisfactory arrangements are made for the custody of canteen money. Where practicable, a banking account should be opened for the purpose and be operated upon by at least two members of the Canteen Committee, one of whom is to be the Executive Officer.
(ii) Moneys retained on board, except such as may be necessary for change purposes in the canteen, are to be kept in the possession of an officer, and a suitable record kept of all sums received and issued, against which signatures are to be shown.

9. *Security of canteen stores*: The Captain is to ensure that suitable lock-up accommodation is provided for the safety of all canteen stores.
10. *Half-yearly Report and Balance Sheet*: A report on the operations of the canteen is to be forwarded to the Director of Victualling on 30th June and 31st December of each year, also on paying off. This report is to be accompanied by a certified copy of the balance sheet as on those dates. The persons certifying to the correctness of the balance sheet should be the representatives of the Canteen Committee referred to in paragraph 7 above, and the valuation of unsold stock is to be calculated at the current ship's price list referred to in paragraph 5 above.

(427/201/909.)

RESTRICTED.(FOR OFFICIAL USE ONLY.)

Commonwealth Navy Orders.

Navy Office, Melbourne,
28th November, 1944.

The following Orders, having been approved, are hereby promulgated for information and guidance, and necessary action.

By direction of the Naval Board,

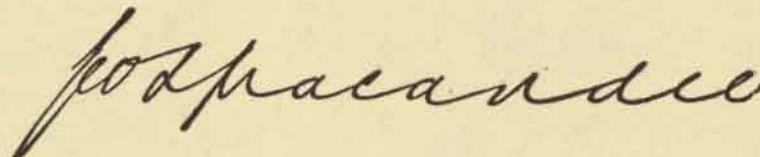

Secretary.

*The Commodore Commanding H.M.A. Squadron,
and Commanding Officers of H.M.A. Ships,
Officers in Charge of H.M.A. Naval
Establishments, and others concerned.*

TABLE OF CONTENTS.

No.	Subject.
619.	Director of Education and Vocational Training.
620.	Air Mails.
621.	R.A.N.R. and R.A.N.V.R. Medical and Dental Officers—Qualified Status.
622.	Appointment of Port Division Naval Medical Officer—Geelong.
623.	Gunnery Non-Substantive Ratings—Recommendations for Q.R.2.
624.	Ammunition Outfits of Small Ships—Arrangements for Periodical Exchange Ammunition, &c.
625.	R.A.N. Establishments of Naval Stores.
626.	Installation of General Messing in Small Ships.
627.	Issue of Mess Gear and Blankets to Personnel Travelling.
628.	Contracts for Supply of W.R.A.N.S. Ratings' Made-to-measure Jackets and Skirts.
629.	Commonwealth Legal Service Bureaux.

619.

DIRECTOR OF EDUCATION AND VOCATIONAL TRAINING.

The Director of Education and Vocational Training is authorized to correspond direct with the Commanding Officers of H.M.A. Ships and with Naval Officers-in-Charge, on routine matters connected with the Reconstruction Training Scheme (*vide* Navy Order 524 of 1944). Naval Officers-in-charge and Commanding Officers may also communicate direct with the Director of Education and Vocational Training on routine matters which do not require the decision of the Naval Board. Correspondence should be addressed:—

The Director of Education and Vocational Training,
Naval Branch,
341 Collins Street,
Melbourne, C.1.

(840/201/14.)

620.

AIR MAILS.

Advice has been received from the P.M.G's Department that the Australia—India—U.K. Air Mail Service is now operating from Australia five times fortnightly.

2. Air Mail matter will be accepted at all G.P.O's on the condition that, whilst air transmission throughout is anticipated, it cannot be guaranteed.

(632/214/625.)

621.

R.A.N.R. AND R.A.N.V.R. MEDICAL AND DENTAL OFFICERS—QUALIFIED STATUS.

The provisions of A.F.O. 4572/44, relating to the granting of Qualified Status to Medical and Dental Officers of the R.A.N.R. and R.A.N.V.R. have been adopted in the R.A.N.

(432/205/5526)

622.

APPOINTMENT OF PORT DIVISION NAVAL MEDICAL OFFICER—GEELONG.

Surgeon Commander Clive H. R. James, R.A.N.R. (Unmobilized), has been appointed Port Division Naval Medical Officer, Geelong. His address is 250 Latrobe-terrace, Geelong, Victoria. (Telephone: Geelong 2346.)

(432/202/703.)

623.

GUNNERY NON-SUBSTANTIVE RATINGS—RECOMMENDATIONS FOR Q.R.2.

There is at present an acute shortage of Q.R.2 ratings in the Royal Australian Navy.

2. As the numbers of C.R.2 and L.R.2 rates borne are sufficient to meet present requirements, no further courses for those rates will be held until the shortage of Q.R.2 is largely made up.

3. Ratings who have passed for Leading Seaman and above and who have been recommended for C.R.2 or L.R.2 are to be informed accordingly, and, in view of paragraph 1, they are to be given the option of undergoing the course for Q.R.2.

(614/210/25.)

624.

AMMUNITION OUTFITS OF SMALL SHIPS—ARRANGEMENTS FOR PERIODICAL EXCHANGE EXAMINATION, ETC.

The following amendment is to be made to Navy Order 325 of 1944, paragraph 2:—

Under the heading—

“II. Outfits to be changed every nine to twelve months”
Add “Landing Ships”.

(659/203/604.)

R.A.N. ESTABLISHMENTS OF NAVAL STORES.

The under-mentioned R.A.N. Establishments of Naval Stores, as distinct from Admiralty Printed Establishments, have been distributed to all Authorities concerned:—

<i>Subject.</i>	<i>Identification No.</i>
Establishment of Naval Stores for H.M.A. Boom Defence Depots	L.E.1
Establishment of Naval Stores for R.A.N. Shore Wireless Stations	L.E.2
Establishment of Naval Stores for Air-Sea Rescue Vessels	L.E.3
Establishment of Naval Stores for Controlled Mining (O) Laying Parties	L.E.4
Establishment of Naval Stores for Controlled Mining Base	L.E.5
Establishment of Naval Stores for C/M Minelaying Tenders	L.E.6
Establishment of Naval Stores for C/M and C/M.O. Stations	L.E.7
Establishment of Naval Stores for Maintenance of Motor Launches and Ford V8 Engines	L.E.8
Establishment of Naval Stores for Motor Patrol Boats ..	L.E.9
Establishment of Naval Stores for Base Repair Depots ..	L.E.10
Establishment of Naval Stores for R.A.N. Beach Commandos and Beach Signal Sections	L.E.12
Establishment of Naval Stores for Ordnance Base Staffs	L.E.13
Establishment of Naval Stores for Port Director Units ..	L.E.14
Establishment of Base A/S Spares	L.E.15
Establishment of Base E/S Spares	L.E.16
Establishment of Base Spares for 25 K.W. Diesel Generators	L.E.17
Establishment of Tools for Base A/S Staffs	L.E.18
Establishment of Naval Stores for 85-ft. Motor Store Lighters	L.E.19
Establishment of Tools for Radar Bases	L.E.20
Establishment of Naval Stores for 75-ft. Loop Repair Vessels	L.E.21
Establishment of Naval Stores for—	
120-ft. Motor Refrigerated Lighters	L.E.22
120-ft. Motor Water Lighters	L.E.22
120-ft. Motor Store Lighters	L.E.22

NOTE.—L.E.11—Establishment of Naval Stores for Naval Beach Parties—has been superseded by L.E.12 referred to above.

2. Identification numbers have been allocated to R.A.N. Local Establishments (L.E.) as indicated above, and all distributed copies of the various Establishments should be endorsed with the relevant L.E. No.

3. Navy Order 135 of 1944 is hereby cancelled.

(612/226/1225.)

INSTALLATION OF GENERAL MESSING IN SMALL SHIPS.

The gradual installation of general messing in all H.M.A. Destroyers, Sloops, Frigates and A.M.S. Ships, in substitution of the present repayment victualling system, has recently been commenced.

2. For the purpose of instituting and expediting the change to general messing, Mr. A. B. Godfrey, Warrant Supply Officer, has been specially detailed for that duty, being borne in H.M.A.S. *Penguin*. He will proceed to each ship concerned as opportunity offers and will remain as long as is considered necessary to install and supervise the revised messing arrangements. All possible assistance should be given him by Commanding Officers to enable the change of system to be expeditiously completed.

3. Where facilities exist for the cafeteria method of food service to be installed, arrangements will be made by Mr. Godfrey for the provision of the necessary metal trays for the purpose.

4. Officers' messes may elect to be included in the general messing scheme if they so desire.

5. In ships where general messing has replaced the repayment system of victualling, the use of form A.S. 462z is to be continued for recording all transactions relative to the receipt and issue of provisions. Where officers decide to continue the repayment system of victualling, the transactions of the officers' mess are to be recorded as provided for in the printed form, but general mess issues are to be recorded and valued daily in a similar manner to repayment issues of one mess, the average daily cost per head at the end of the month, or other period concerned, being entered at the foot of the page of the account. A special general mess form for use in the above classes of ships is in course of preparation and will be issued to all concerned, without demand, as soon as available. It will probably be numbered A.S. 462a.

6. A series of suitable menus, together with a scale of quantities to be issued, also detailed instructions for the guidance of Commanding Officers and the supply and cooking staff, will also be distributed to all ships concerned as early as practicable. Information of this nature will meanwhile be furnished by Mr. Godfrey direct to each ship as general messing is installed.

(612/211/3844.)

ISSUE OF MESS GEAR AND BLANKETS TO PERSONNEL TRAVELLING.

With reference to paragraph 7 of Navy Order 170 of 1944, the responsibility for collection and issue of mess gear at Brisbane has been transferred to the Railway Transport Officer, and the last line of that paragraph is to be amended to read "Naval Railway Transport Officer, Brisbane."

(530/201/531.)

628.

**CONTRACTS FOR SUPPLY OF W.R.A.N.S. RATINGS'
MADE-TO-MEASURE JACKETS AND SKIRTS.**

As from 1st March, 1944, the price of jackets, double-breasted, diagonal serge, with horn buttons, supplied under contract by Messrs. David Jones Ltd., Sydney, is increased from £2 13s. 1d. to £2 15s. 10d.

2. Navy Order 406 of 1944 is to be amended accordingly.

(434/216/98.)

629.

COMMONWEALTH LEGAL SERVICE BUREAUX.

There has been established at each of the capital cities of the Commonwealth by the Attorney-General for the Commonwealth, a Legal Service Bureau for the purpose of providing free legal advice and, on some matters, assistance for members of the Fighting Services and their dependants.

2. A booklet describing the activities of the Legal Service Bureau will shortly be distributed to each member of the Fighting Services.

3. Where it is not possible to consult the Bureau personally, correspondence on any matter on which legal advice is desired may be addressed to the Officer-in-Charge of a Bureau, preferably in the home State of the inquirer.

4. The following are the addresses of the Legal Service Bureaux:—

Melbourne.—318 Post Office Place.

Sydney.—Commonwealth Bank Chambers, Martin Place and Pitt Street.

Brisbane.—Inns of Court, 21 Adelaide Street.

Perth.—Atlas Building, 8-10 The Esplanade.

Adelaide.—Epworth Building, Pirie Street.

Hobart.—City Mutual Building, Macquarie Street.

(450/201/128.)

(This Order will be reprinted for posting on Notice Boards.)

RESTRICTED.

(FOR OFFICIAL USE ONLY.)

Commonwealth Navy Order.

Navy Office, Melbourne,
5th December, 1944.

The following Order, having been approved, is hereby promulgated for information and guidance and necessary action.

By direction of the Naval Board,

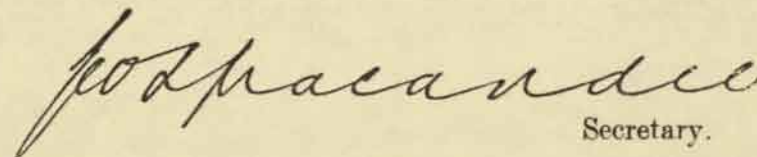
Secretary.

*The Commodore Commanding H.M.A. Squadron,
and Commanding Officers of H.M.A. Ships,
Officers in Charge of H.M.A. Naval
Establishments, and others concerned.*

TABLE OF CONTENTS.

No.	Subject.
630.	Clothes Rationing—Naval Personnel.
C.12714/44.	

CLOTHES RATIONING—NAVAL PERSONNEL.

Rationing Year 1944-1945.

The following instructions in regard to the application of civilian clothes rationing to Naval Personnel for the rationing year which commenced on 5th June, 1944, are promulgated for information and guidance:—

PART I.—PROVISION AND MAINTENANCE OF UNIFORM AND CLOTHING.

2. Requirements of uniform and clothing taken up on repayment from Naval stocks do not necessitate the surrender of coupons. Made-to-measure uniforms obtained under current Naval contracts (ratings) or agreements (officers), as notified in Navy Orders from time to time, or from the Commonwealth Clothing Factory also do not necessitate coupon surrender provided that Service materials obtained by the contractors from Naval stocks are used. New Form A.S.87X has been adopted for such orders and will be distributed in due course. Pending its receipt, authority to purchase from outfitters is to be issued in the following form:—

AUTHORITY TO SUPPLY MADE-TO-MEASURE UNIFORM CLOTHING.

H.M.A.S.

Date

Made-to-measure naval uniform, as detailed hereunder, may be supplied to the officer or rating indicated below under the terms of your contract or agreement with the Department of the Navy.

Name (in Block Letters).	Rank or Rating (also Official Number in the Latter Case).	Description of Articles Authorized to be Supplied.	Number of each Article (in Words).

To

(See Note 1 below.)

Officer Authorizing Supply.

(See Note 2 below.)

Rank.

NOTE 1.—Name and address of the outfitter is to be inserted by the officer or rating on presentation of the order.

NOTE 2.—Authority is to be signed by the Accountant Officer, where one is borne, otherwise by the Commanding Officer, and is to be delivered to the outfitter by the officer or rating concerned.

NOTE 3.—The outfitter is required to obtain hereon, or separately if necessary, from the person supplied a receipt in the following form "Received the above completed garments totalling.....No." (number to be shown in words).

The above authority is to be restricted to the minimum articles necessary for current Service use, and a copy is to be retained for reference purposes by the issuing officer.

Coupon surrender is not necessary in respect of uniform made up by any outfitter from Service materials, *vide* paragraph 3 of Navy Order 493 of 1944, except in respect of linings and trimmings which may be used by the contractor from his private stocks.

COUPON ENTITLEMENT.

3. For purposes of issue of Service clothes rationing coupons, the Rationing Year is divided into the following periods, showing the coupon issues applicable:—

To Whom Applicable.	Persons Serving on 5th June, 1944, or Entered between 5th June, 1944, and 15th October, 1944.	Persons Entered between 15th October, 1944, and 15th February, 1945.	Persons Entered between 16th February, 1945, and end of Rationing Year.
Royal Australian Navy	25	15	5
Royal Australian Naval Nursing Service (See * below)	50	35	20
Women's Royal Australian Naval Service	35	20	10

* Members of the Royal Australian Naval Nursing Service posted to New Guinea are to be issued with additional coupons as follows:—

5/ 6 /44 to 15/10/44	15
16/10/44 to 15/ 2 /45	10
16/ 2 /45 to end of Rationing Year	5

The above issues are intended to enable personnel to purchase necessary items of clothing not stocked by the Naval Service, and are to cover purchases from commercial sources during the 1944/1945 rationing year. Coupons are negotiable at any time during that period.

4. Bulk supplies of the special ration sheets are to be demanded by the Naval Officer-in-Charge at Sydney, Brisbane, Fremantle, Port Adelaide or Hobart from the Deputy Director of Rationing of the State concerned. Requirements of the Naval Officer-in-Charge, Flinders Naval Depot, Port Melbourne or Darwin are to be demanded from the Director of Victualling. H.M.A. seagoing ships and naval establishments are to demand their actual requirements of ration sheets, allowing a margin of ten (10) per cent. for casual issues, from any of those authorities as most convenient. The requirements of tenders, port war signal stations, shore wireless stations, &c., are to be issued by the parent ship or establishment concerned.

5. Ration sheets are to be issued to all personnel without acquittance, but a permanent record is to be maintained in ships and establishments, showing the following information:—

- (a) total numbers of ration sheets received, serial numbers thereof, and source of supply;
- (b) name, rank, rating and official number, as requisite, of each person to whom a ration sheet is issued;
- (c) serial number of the ration sheet with which each officer or rating is issued;
- (d) date of issue; and
- (e) number of any unissued ration sheets, serial number thereof and final disposal.

Name, rank or rating, official number and signature are to be inserted at the time of issue of the sheets.

6. The following are to be rendered to the Director of Victualling as at 15th September, 1944, 15th February, 1945, and at the end of the rationing year :—

- (a) By Naval Officers-in-Charge, Sydney, Flinders Naval Depot, Port Melbourne, Brisbane, Fremantle, Port Adelaide, Hobart and Darwin, a return indicating—
- (i) numbers of clothes ration sheets of each type received during the period, serial numbers and sources of supply;
 - (ii) numbers of sheets issued;
 - (iii) ships (other than tenders) supplied; and
 - (iv) balances unexpended and their disposal.

(b) By Commanding Officers of sea-going ships—a certificate signed by an officer (who is to be the Accountant Officer where borne) and approved by the Commanding Officer, indicating—

- (i) number of sheets received, serial numbers of sheets, and source of supply;
- (ii) total number of sheets and serial numbers of sheets issued;
- (iii) total balance unexpended and disposal; and
- (iv) that all issues have been recorded in the ship's ledger, other appropriate record, or reported to parent ship,

copy of the certificate being forwarded to the Naval Officer-in-Charge from whom original supply was obtained.

7. A notation is to be made in the remarks column of the ledger, opposite the name of every officer and rating borne, indicating the serial number of the ration sheet issued and the date of issue. Parent ships are responsible for such notation in the case of tenders. A similar notation is to be made on Transfer Lists (Form A.S.45).

8. The use of clothing ration coupons is governed by the National Security (Rationing) Regulations, and Naval personnel are subject to the penalties contained therein for misuse of coupons. Members of the Naval Service are required to take special care to ensure that the ration sheets with which they are issued, and which become their personal property, are not lost, damaged, or defaced. The Commanding Officer may, however, authorize the issue of a new ration sheet to replace one that is lost if, after investigation, he is satisfied that the circumstances warrant that course. The member applying for replacement of a lost ration sheet is to furnish a certified statement as to the number of coupons surrendered up to the date of loss of the sheet. Ration sheets issued in replacement are to be reduced by that number, or by two coupons for males, three coupons for members of the Women's Royal Australian Naval Service, and four for members of the Royal Australian Naval Nursing Service for every month or part of a month of the expired portion of the rationing year, whichever number is the greater. Particulars of such replacement issues, including the serial number of the new sheet and the number of coupons issued, are to be reported, as they occur, to the Director of Victualling, coupons excised being affixed to the report.

PART II.—SPECIAL ISSUES.

9. *Personnel Finally Discharged and Personnel Temporarily Released.*

Procedures in regard to issues of special clothes rationing coupons to Naval personnel on final discharge, or on temporary release, are laid down in Navy Order 14 of 1944 which is to be amended by deleting the final sentence in paragraphs 3 and 7.

10. *Replacement of Personal Clothing Lost.*

To enable personnel who have lost the whole or portion of their uniform and other articles of clothing as a result of enemy action, casualty of the Service, other accident, pillage or theft to effect replacement of such rationed items as are not obtainable from Naval stocks, the following special issues of Service clothing coupons will be made to all Naval personnel :—

(a) *Entire Loss—Male Personnel.*

An issue of coupons, up to a maximum of 200 No. for officers and 50 No. for ratings, may be made by a Commanding Officer when he is satisfied that a person's entire outfit of apparel has been lost. Where sufficient information as to the circumstances of loss is not available, the case is to be referred to the Director of Victualling for decision.

Clothes ration books for these issues are to be demanded, as required, from the most convenient of the authorities referred to in Part I., paragraph 4, above.

(b) *Partial Loss—All Personnel.*

When a member sustains loss of a portion of his or her outfit of apparel under the circumstances indicated above, application for special issue is to be forwarded to the Director of Victualling.

The following information is to be furnished :—

- (i) name, rank or rating (official number if a rating);
- (ii) certified statement, signed by the claimant and witnessed by a commissioned officer, as to—
 - (a) ship or place, occasion and circumstances of the loss, together with the result of civil police investigation, if any, and
 - (b) details of articles requiring replacement, and of quantities of similar articles remaining in the member's possession; and

(iii) Commanding Officer's recommendation, stating whether any blame is attributable to the member for the loss. Recommendation is to take into consideration the quantity of individual articles still held by the applicant. If a member possesses articles of the type claimed equal to or in excess of the quantities shown in schedules in paragraph 11 hereunder, approval for coupon replacement will not be given.

If the application is approved, the Deputy Director of Rationing in the appropriate Capital City will be requested to issue the necessary "Permit to Purchase".

11. The following schedules of rationed articles of clothing of a personal nature form the bases for the maximum special replacement issues under paragraph 10, coupon values being indicated against each item:—

(a) *Male Personnel.*

(i) *Officers.*

1 pr. grey trousers	10	coupons
1 pr. civilian shoes	12	"
1 pr. sports shoes	12	"
2 prs. of socks	8	"
2 shirts	24	"
4 collars	4	"
1 hat	6	"
1 sports jacket	20	"
1 pullover	9	"
2 singlets	10	"
2 prs. of underpants	10	"
1 dressing gown	15	"
2 prs. pyjamas	30	"
Sundries	30	"
Total	200	coupons

(ii) *Ratings.*

1 pr. sports trousers	10	coupons
1 sports shirt	12	"
1 pr. of shoes	12	"
1 pr. of slippers..	5	"
1 pr. of socks	4	"
Sundries	7	"
Total	50	coupons

(b) *Females—Officers and Ratings.*

3 prs. of pyjamas	42	coupons
1 dressing gown	15	"
1 pr. slippers	3	"
1 pr. corsets	4	"
2 prs. brassieres	4	"
1 winter dress	13	"
1 summer dress	13	"
1 slip	8	"
1 pr. shoes	8	"
2 prs. stockings	8	"
1 hat	3	"
1 bathing costume	5	"
Total	126	coupons

12. *Loss of Bed Linen.*

The conditions laid down in paragraph 10 are applicable to sheets and pillow covers. The maximum replacement issue will be 62 No. coupons, to cover three pairs of single sheets and two pairs of pillow cases.

13. Personnel not accommodated in ships or establishments, and who live in private homes or establishments where they are required to maintain their own requirements of bed linen, may apply for coupon issue for replacement to the Deputy Director of Rationing in the nearest Capital City, who will deal with the matter on a "hardship" basis, taking into account the total quantity of bed linen in the possession of the household.

14. The provisions of paragraphs 10 (b), 12 and 13 operate as from 5th June, 1944.

15. *Bed Linen—Rationing of.*

Instructions promulgated in Navy Order 183 of 1944 regarding special issues of clothes ration coupons for (a) initial provision, and (b) annual maintenance of bed linen, are to be amended as follows:—

(1) Paragraph 1 (i)—In heading, before "Officers" insert "Male".

(2) Paragraph 1 (ii)—Add final sentence:—

"Maintenance issue for the current rationing year is not to be made to personnel entered or promoted after the 15th February, 1945".

(3) Paragraph 3—Amend last sentence to read:—

"Returns of "Permits to Purchase" and of coupon maintenance sheets issued are required as at 15th October, 1944, 15th February, 1945, and the closing date of the rationing year".

16. *Household Linen—Outfit of.*

Members of the Royal Australian Navy, Royal Australian Naval Nursing Service and Women's Royal Australian Naval Service about to furnish homes may obtain coupons for the purchase of initial supplies of household drapery by personal application to the Deputy Director of Rationing. Such coupons are for the purchase of household drapery only, and are not to be used for the purchase of clothing.

PART III.—GENERAL.

DECEASED NAVAL PERSONNEL—DISPOSAL OF RATION BOOKS OR SHEETS.

17. Ration books or ration sheets found amongst the effects of deceased Naval personnel are to be destroyed by, or in the presence of, a senior officer and a certificate furnished to the Director of Victualling, indicating:—

- serial number of book or sheet, and office of issue;
- rank or rating (official number if a rating), and date of death;
- coupon value of book or sheet destroyed (e.g., 50, 25);
- number of coupons destroyed; and
- ship in which borne at time of death.

18. *Detachment of Coupons.*

Under civilian ration regulations, coupons may be detached from books or sheets only by the supplier of rationed commodities. To enable members serving in areas where the personal presentation of books or sheets is not possible, and who desire purchases to be made by their agents, i.e., relatives or friends, the Director of Rationing has approved that detached "Service" coupons may be accepted by retailers, subject to affixment to an official form or document, signed by the member concerned and countersigned by his Commanding Officer. Clothes ration coupon scales may be obtained through Naval Issuing Authorities.

19. *D.E.M.S. Ratings.*

Issues of clothes rationing coupons are to be made by Base Accountant Officers as opportunity arises. Notation of issue is to be made in the rating's pay book, and his Depot informed. In the case of transient D.E.M.S. ratings, e.g., R.N. ratings passing through the Station, requirements may be referred to Deputy Directors of Rationing or dealt with by the Naval Officer-in-Charge, as necessary.

20. *Civilian Ration Books—Surrender on Entry.*

On entry into Naval Service every person, except a member of the Naval Dockyard Police, is required to surrender civilian ration card and book to the Recruiting Officer, or to the Commanding Officer, immediately after entry.

21. Should an entrant not produce a civilian ration book and card, he is to be interrogated at once as to their disposal. A signed statement, witnessed by a responsible officer, is to be obtained, showing his previous address. Such cases are to be reported, as they occur, to the Deputy Director of Rationing of the State of original issue and of the State of entry into Naval Service, and a copy forwarded to the Director of Victualling.

22. Surrendered ration cards and books are to be scrutinized for irregularities, particularly in regard to the abstraction of coupons which have not become current, or advance abstraction of non-operative food coupons. Where irregularities are detected, the person surrendering the documents is to be interrogated at once as to the disposal of coupons wrongfully abstracted, informed that such removal constitutes a breach of rationing regulations punishable in the civil courts, and directed to take immediate steps to effect recovery. Such cases are to be reported forthwith to the appropriate Deputy Director of Rationing accompanied by the rationing documents affected, copy of such report being forwarded to the Director of Victualling. Ships to which personnel concerned are appointed or drafted are also to be informed. Until instructions are received from the Deputy Director of Rationing, or the Director of Victualling, no issue of Service coupons is to be made for commodities covered by the coupons wrongfully abstracted. Such sheet of surrendered civilian ration cards and books is to be cancelled by a rubber stamp, or other method sufficient to ensure that the entire page is rendered useless.

23. Recruiting Officers or Commanding Officers at ports of direct entry are to render to the Deputy Director of Rationing in their respective States, at the end of each calendar month, a statement, as per pro forma hereunder, together with cancelled civilian ration books. Notations of action under paragraphs 21 and 22 above are to be made in column 4 thereof.

PRO FORMA.

H.M.A.S. _____

Date _____

Persons Entered, and Disposal of Civilian Ration Books.

Period _____

Date of Entry.	Name.	Ration Book Number.	Number of Coupons Used.
			A.B.C.D.E., &c.

Certified that the above list includes all persons entered into H.M.A. Naval Service through this establishment during the period _____ to _____

Rank _____
(Appointment.) Date _____

RATIONED GOODS FOR ORGANIZED GROUPS—SPORTSWEAR, THEATRICAL EQUIPMENT, ETC.

24. The purchase of rationed goods of the nature of sportswear, theatrical properties, &c., required for communal use in H.M.A. Ships or Establishments may be arranged by application, in triplicate, to the Director of Victualling, as per pro forma hereunder. After examination, applications will be referred to the Director of Rationing for covering "Permit to Purchase", which will be forwarded to the requisitioning ship or establishment or, if desired, to any naval authority nominated to effect purchase in the absence of a ship from proposed source of supply.

PRO FORMA.

H.M.A.S. _____

Date _____

DIRECTOR OF VICTUALLING.

It is requested that covering Rationing "Permit to Purchase" be provided for the under-mentioned articles of amenities.

Name and Address of Supplier.	Full Description of Goods.	Quantity.	Remarks.

I certify that the goods above detailed are for communal use in H.M.A. Ship under my command and will remain the property of the Ship.

Rank _____
Commanding Officer.

Date _____

25. Purchases are to be strictly controlled and are to be limited to actual requirements. Abuse of this privilege will lead to its withdrawal by the Rationing Authority.

26. *Safe Custody of Rationing Documents.*

Stocks of ration books, sheets, &c., and rationing documents are to be placed in the custody of a responsible officer, and issues are to be made only on the authority of the Naval Officer-in-Charge, or Commanding Officer, who is responsible that suitable records are maintained of all transactions and that every precaution is taken to avoid abuses or unauthorized issues.

27. *Individual Approach to Rationing Authorities.*

Except as indicated in paragraphs 13 and 16 above, no member is under any circumstances to make direct representation to the Rationing Directorate on any matter relating to Service rationing.

28. *Retrospective Operation of This Order.*

This Order is to apply as from Monday, 5th June, 1944, from which date Navy Order 480 of 1943 is cancelled. Copies of this Order will not be reprinted for posting on Notice Boards, but Commanding Officers are to ensure that all essential information is promulgated within their commands.

(350/201/70.)

RESTRICTED.(FOR OFFICIAL USE ONLY.)

Commonwealth Navy Orders.

Navy Office, Melbourne,
5th December, 1944.

The following Orders, having been approved, are hereby promulgated for information and guidance, and necessary action.

By direction of the Naval Board,

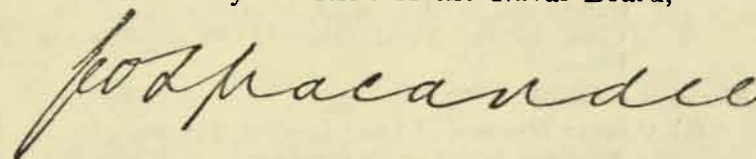

Secretary.

*The Commodore Commanding H.M.A. Squadron,
and Commanding Officers of H.M.A. Ships,
Officers in Charge of H.M.A. Naval
Establishments, and others concerned.*

TABLE OF CONTENTS.

No.	Subject.
631.	Ordnance and Electrical Mechanics.
632.	Gunnery Non-Substantive Ratings—Exceptional Qualification for Higher Rating.
633.	Visual Signallers, Coders, T/P and Automatic Morse Operators, W.R.A.N.S.—Advancement.
634.	Tubes, Friction, M.R. Signal—Failures.
635.	Ammunition Supply—Naval Armament Depots—Supply Tests and Returns of Ammunition—Report.
636.	Tubes, Friction, Machine, Rocket Signal, Mk. IV—Lots 93 and 94, Filled 3/43 W.F. Ltd.—Withdrawal.
637.	Gun Mountings 4-in. Mk. XXIII and XXIII*—Lubrication of Centre Pivot.
638.	Woven Badges—Introduction in R.A.N.
639.	Recharging of Cylinders for "Nuswift", "Graviner" and "Essex" Type Fire Extinguishers.
640.	Storage of Effects of Deceased Personnel.
641.	Use of Army Medical Facilities in Transfer of Invalids.
642.	Despatch of Advance Supply Notes for Naval Stores Shipped, &c. from H.M.A. Naval Store Depots.
643.	Concession Railway Fares for Service Personnel Travelling in Uniform and Paying their own Fares.
644.	Engagement of Service Personnel in the Police Force.
645.	Action Rations.

631.

ORDNANCE AND ELECTRICAL MECHANICS.

Following are the conditions of service and advancement of Ordnance and Electrical Mechanics adopted by Navy Order 82 of 1944.

2. Ordnance Mechanic.

- (i) Rating is open to Able Seaman (Q.O.) only. Selected ratings must have had sea-going experience in the non-substantive rating of Q.O.
- (ii) On selection, ratings will be drafted for a sixteen weeks' course at Melbourne Technical College in fitting and turning, on successful completion of which they will be given five weeks' gunnery course at the R.A.N. Gunnery School.
- (iii) On satisfactory completion of the course, a rating will be transferred to the rating of Ordnance Mechanic, 5th Class, by the Naval Officer-in-Charge, Flinders Naval Depot.

3. Electrical Mechanic.

- (i) Open to Wiremen (L) and Leading Wiremen (L) who have completed twelve months' sea service as Wiremen and have shown an aptitude for mechanical work.
- (ii) Selected ratings will be given a sixteen weeks' course in fitting and turning at a technical school, on successful completion of which they will be given a modified E.A. Course, at R.A.N. Torpedo School. On satisfactory completion of this course, they will be transferred to Electrical Mechanic, 5th Class, by the Naval Officer-in-Charge, Flinders Naval Depot.

4. Advancement.

- (i) Ordnance and Electrical Mechanics will be advanced to a higher class by the Commanding Officer under the following conditions:—
 - 5th Class (Relative rating Ldg. Smn.) to Acting 4th Class (Relative rating P.O.).
 - (a) One year as 5th Class.
 - (b) Over 21 years of age.
 - (c) Recommended for advancement by technical officer.
- ii) Ratings will be confirmed as 4th Class on completion of twelve months' satisfactory service in the acting rate.
 - 4th Class to 3rd Class—
 - Three years as 4th Class and recommended for advancement.
 - 3rd Class to 2nd Class—
 - Seven years as 4th Class and above.
 - 2nd Class to 1st Class—
 - (a) Twelve years as 4th Class and above.
 - (b) Relative rating of 3rd Class and above to be that of C.P.O.

5. Uniform.

- (i) On transfer, to be Class III without any distinguishing badge.
 - (ii) On confirmation as 4th Class, the uniform of a Petty Officer over one year.
 - (iii) On advancement to 3rd Class, Class I uniform to be worn.
6. Navy Order 526 of 1944 is cancelled.

(348/203/1.)

(This Order will be reprinted for posting on Notice Boards.)

632.

GUNNERY NON-SUBSTANTIVE RATINGS—EXCEPTIONAL QUALIFICATION FOR HIGHER RATING.

The provisions of A.F.O. 4581/44, Gunnery Non-Substantive Ratings—Exceptional Qualification for Higher Rating—have been adopted in the Royal Australian Navy.

(348/216/2.)

633.

VISUAL SIGNALLERS, CODERS, T/P AND AUTOMATIC MORSE OPERATORS, W.R.A.N.S.—ADVANCEMENT.

Paragraph 1, Section (g) of Navy Order 204 of 1944 is hereby cancelled.

(432/224/3102.)

634.

TUBE, FRICTION, M.R. SIGNAL—FAILURES.

Failure of Tubes, Friction, M.R. Signal, involving blow back and fracture of nib, have occurred with tubes of M.R. manufacturer filled M.E. Lot No. 3, date 1/40.

2. Tubes of this Lot are not to be fired and are to be returned to the nearest Naval Armament Depot and others drawn in lieu.

3. Where use of Tubes of this Lot No. is unavoidable, personnel should take cover.

(471/208/1145.)

635.

**AMMUNITION SUPPLY—NAVAL ARMAMENT DEPOTS—SUPPLY,
TESTS AND RETURNS OF AMMUNITION—REPORT.**

Appended for information and action as necessary, is a copy of Admiralty Fleet Order 5040/44, which has not yet been promulgated on the Australia Station:—

“All cartridges containing cordite of the following lots and sub-lots on board sea-going ships are to be landed at the first opportunity after receipt of this order:—

Lot No.	Size.	Cartridges into which filled.
W.A.13140	RDN/A052	Q.F. 4.7 in. IX-IX* gun
W.A.13145	RDN/A052	Q.F. 4.7 in. IX-IX* gun
W.A.13147	RDN/A029	Q.F. 3 in. 20 cwt. gun Q.F. 4 in. V-V* gun
W.A.13147 XA	RDN/A029	Q.F. 3 in. 20 cwt. gun Q.F. 4 in. V-V* gun
W.A.13147 XB	RDN/A029	Q.F. 3 in. 20 cwt. gun Q.F. 4 in. V-V* gun
W.A.13148 XA	RDN/A029	Q.F. 3 in. 20 cwt. gun Q.F. 4 in. V-V* gun
W.A.13148 XB	RDN/A029	Q.F. 3 in. 20 cwt. gun Q.F. 4 in. V-V* gun
W.A.13333 XC	RDN/A029	Q.F. 4 in. V-V* gun
M.E. 782	16 M.C.	B.L. 6 in. VII gun
M.E. 782 Y	16 M.C.	B.L. 6 in. VII gun
M.E. 783	16 M.C.	B.L. 4 in. IX gun
M.E. 783 Y	16 M.C.	B.L. 4 in. IX gun
M.E. 790	16 M.C.	B.L. 6 in. VII gun
M.E. 790 Y	16 M.C.	B.L. 6 in. VII gun

2. At depots abroad, cordite in all cartridges so received, together with any in store, is to be destroyed forthwith.

3. At home depots, any cartridges or bulk cordite of the above lots and sub-lots required for trials, experiments or gunnery school firings may be retained until 30th June, 1945.”

(408/207/2331.)

636.

**TUBES, FRICTION, MACHINE, ROCKET SIGNAL, MK. IV—LOTS 93
AND 94, FILLED 3/43 W.F. LTD.—WITHDRAWAL.**

The following advance copy of Admiralty Fleet Order 5037/44 is promulgated for information and necessary action:—

“Tubes, friction, machine, rocket signal Mk. IV, Lots 93 and 94, filled W.F. Ltd., 3/43 on board H.M. Ships are to be landed at the first opportunity and others demanded in lieu.

2. Stocks at Naval Armament Depots, together with those returned, are to be brought to produce.”

(471/2084/1224.)

637.

**GUN MOUNTINGS 4-IN. MK. XXIII AND XXIII*—LUBRICATION OF
CENTRE PIVOT.**

To facilitate the Lubrication of Centre Pivots of 4-in. Mk. XXIII and XXIII* Mountings with Special Mineral Lubricating Oil, in accordance with Navy Order 566 of 1944, it is approved to replace the existing Rotherham's Grease Cup Pattern No. 4167 by fitting an Oil Lubricator, Rotherham's Revolving Lid Type Pattern No. 4141.

2. The Oil Lubricators are to be drawn from Naval Stores and fitted by Ships' Staffs or Ordnance Base Staffs.

(490/203/1230.)

638.

WOVEN BADGES—INTRODUCTION IN R.A.N.

In order to overcome supply difficulties, it has been decided that woven badges will be supplied in future as a wartime substitute for certain normal worsted-type badges.

2. Until present stocks are exhausted, demands for badges will be met wholly or in part by the supply of the worsted-type article.

3. The pattern numbers of the woven badges referred to, the prefix “X” indicating such badges, and the rates at which issues are to be charged are as follow:—

					£	s.	d.
X1a	Petty Officers	red	each	0	0 5
X1b	”	blue	”	0	0 5
X3a	Leading Ratings	red	”	0	0 3
X3b	”	blue	”	0	0 3
X6a	Stoker Petty Officers	red	”	0	0 7
X17a	Leading Signalman, 3rd Class	red	”	0	0 8
X17b	”	blue	”	0	0 8
X19a	Trained Operator (V/S)	red	”	0	0 5
X19b	”	blue	”	0	0 5
X20a	Signalmen not trained Operator (V/S) and Ordinary Signalmen	red	”	0	0 3
X20b	Signalmen not trained Operator (V/S) and Ordinary Signalmen	blue	”	0	0 3
X26a	Leading Stokers and Stokers 1st Class	red	”	0	0 4
X26b	Leading Stokers and Stokers 1st Class	blue	”	0	0 4
X27a	Stokers, 2nd Class	red	”	0	0 3
X27b	”	blue	”	0	0 3
X62b	Wireless Telegraphist, 3rd Class	blue	”	0	0 6
X63a	Trained Operator (W/T)	red	”	0	0 5
X63b	”	blue	”	0	0 5
X64a	Telegraphist, not trained Operator (W/T) and Ordinary Telegraphists	red	”	0	0 4

				£	s.	d.
X64b	Telegraphist, not trained Operator (W/T) and Ordinary Telegraphists	blue	each	0	0	4
X115a	Petty Officers, Others ..	red	"	0	0	3
X115b	"	blue	"	0	0	3
X118a	Letter "C" ..	red	"	0	0	2
X118b	"	blue	"	0	0	2
X123a	Leading Torpedo Men—Other Ratings	red	"	0	0	8
X123b	Leading Torpedo Men—Other Ratings	blue	"	0	0	8
X135a	Writer	red	"	0	0	3
X135b	"	blue	"	0	0	3
X136a	Supply Rating	red	"	0	0	3
X136b	"	blue	"	0	0	3
X137a	Cook	red	"	0	0	3
X137b	"	blue	"	0	0	3
X138a	Officers' Steward	red	"	0	0	3
X138b	"	blue	"	0	0	3
X151b	Layer Ratings, 3rd Class Leading Ratings and below	blue	"	0	0	5
X157a	Control Ratings, 3rd Class Leading Ratings and below	red	"	0	0	5
X157b	Control Ratings, 3rd Class Leading Ratings and below	blue	"	0	0	5
X163a	Anti-Aircraft Ratings—3rd Class Leading Ratings and below ..	red	"	0	0	5
X163b	Anti-Aircraft Ratings—3rd Class Leading Ratings and below ..	blue	"	0	0	5

(416/201/996.)

(This Order will be reprinted for posting on Notice Boards.)

639.

RECHARGING OF CYLINDERS FOR "NUSWIFT", "GRAVINER", AND "ESSEX" TYPE FIRE EXTINGUISHERS.

All cylinders for "Nuswift", "Graviner" and "Essex" Types Fire Extinguishers are to be accounted for as permanent Naval Stores, and an equal number of empty cylinders should be returned when demanding refills for these Extinguishers.

2. The cylinders are recharged in Sydney and, in view of the acute shortage of these items at the present time, Ships and Establishments are immediately to return all available empty cylinders to the Superintending Naval Store Officer, Sydney, for refilling.

(475/203/1.)

640.

STORAGE OF EFFECTS OF DECEASED PERSONNEL.

The utmost care is to be taken to safeguard the effects of deceased personnel. With this object in view the following procedure is to be observed in all H.M.A. Ships and Establishments.

2. As early as practicable after the death of a member, an inventory of effects is to be prepared in duplicate, by a responsible person, and certified to by him and an officer, the original being forwarded to Navy Office for instructions as to disposal in accordance with provisions of Article 121 of Naval Account Regulations and Instructions.

3. In dealing with the effects, all items of value such as cash, watches, fountain pens, propelling pencils, bank pass books, &c., are to be extracted from kits, parcelled separately, suitably labelled, and handed over to an officer whose duty it will be to see that they are locked in a safe and properly accounted for.

4. Where items of value are handed over to a responsible officer, the Kit lists are to be endorsed to the following effect, viz. :—

"Items as under have been parcelled separately, and lodged with.....". (Insert Rank and Name of Accountant or other responsible Officer, as the case may be).

This entry is to be signed by the person making the list and the officer in whose custody the articles have been placed.

5. A record is also to be kept by the responsible officer of all articles placed in his custody, pending instructions as to their despatch to the legal representative, or person entitled to receive them.

6. The remaining effects are to be carefully sealed and stowed in locked storage and held until instructions for their disposal are issued by the Naval Board.

7. A monthly check is also to be made of all packages of effects of deceased personnel held in Baggage Stores, and the result reported to the responsible officer for action as considered necessary. In this connexion, all possible steps are taken in Navy Office to expedite instructions regarding disposal of the effects, but in some instances, owing to legal difficulties, such effects cannot be disposed of immediately. In every case, however, Naval Board authority for their disposal will be issued as soon as possible.

8. Should the effects of deceased personnel be of such nature that it is considered that they should be disposed of immediately, the position is to be reported to the Naval Board, when the necessary instructions will be issued as to action to be taken.

9. Delivery of all such effects is to be made to the person authorized by the Naval Board to receive them, either personally where practicable, or by registered post, and in all cases a detailed receipt from the person authorized to receive them is to be forwarded to Navy Office in due course.

(557/201/167.)

641.

USE OF ARMY MEDICAL FACILITIES IN TRANSFER OF INVALIDS.

Before sending invalids to their home ports or to another region under escort of a Sick Berth Rating, Commanding Officers are to make inquiries of the Deputy Director of Medical Services in their particular State to ascertain the movement of army ambulance trains or parties (walking cases) under medical escort, in order that these facilities may be used for Naval invalids where practicable. Medical care and attention can thus be obtained for them *en route* without the necessity of despatching a Sick Berth Rating especially to care for them.

2. (i) Psychiatric or mental cases, however, who, in the opinion of the Senior Naval Medical Officer, require supervision are to be accompanied by a Naval Medical Officer or Sick Berth Rating when travelling from one Naval Establishment to another, whether such transfer is effected by air or land transport.

(ii) In the case of patients travelling in army ambulance trains, prior consent of the Military authorities is to be sought for the Naval escort. If such consent be withheld, arrangements are to be made for the patient to be met at destination by a responsible Naval Medical escort.

3. Full medical particulars are to be carried by the Naval escort and are to be handed over to the Medical Officer concerned at the termination of the journey.

4. No objection is taken to the escort of invalids by a Sick Berth Rating going on leave to or through cities to which the former are being transferred.

5. Navy Order 259 of 1944 is hereby cancelled.

(527/201/947.)

642.

DESPATCH OF ADVANCE SUPPLY NOTES FOR NAVAL STORES SHIPPED, ETC., FROM H.M.A. NAVAL STORE DEPOTS.

With reference to A.F.O. 3088/43, the procedure set out therein is to be observed in future in regard to the despatch of "advance" Supply Notes, &c., for Naval Stores packed for shipment or despatch by rail or road from H.M.A. Naval Store Depots and Base Naval Stores.

2. The quadruplicate copy of the Issue Vouchers (advance Notes) and the original copy of the packing note, are to be enclosed in a water-proof envelope and attached to the inside of the lid of each packing case or enclosed in the package, &c.

3. Where the stores shown on one advance Supply Note are packed in more than one case and the advance Supply Note is included in the case containing the largest number of items, it is most important that slips indicating in which case the advance Supply Note is contained be included in the other cases, and it is requested that particular attention of all concerned be drawn to this matter.

4. Relevant instructions will be amended accordingly in due course.

(671/203/288.)

643.

CONCESSION RAILWAY FARES FOR SERVICE PERSONNEL TRAVELLING IN UNIFORM AND PAYING THEIR OWN FARES.

The Commonwealth Department of Transport Pamphlet No. 2 issued in January, 1942, set out the conditions under which concession fares would be granted to personnel travelling in uniform and paying their own fares.

2. The procedure for obtaining this concession has now been amended and in future concession fares will only be allowed on production of Railway Travel Certificate (AAF T12) on the following railway systems:—

<i>Railway System.</i>	<i>Interstate.</i>	<i>Intrastate.</i> (Including Suburban Travel.)
Queensland AAF T12 required	.. AAF T12 required.
New South Wales AAF T12 required	.. AAF T12 required.
Victoria AAF T12 required	.. AAF T12 not required.
South Australia AAF T12 required	.. AAF T12 not required.
Western Australia AAF T12 required	.. AAF T12 not required.
Commonwealth AAF T12 required	.. AAF T12 required.
Tasmania AAF T12 not required	.. AAF T12 not required.

3. Personnel desiring concession rates on the railway system where Form AAF T12 is applicable should obtain the certificate before proceeding on leave from their ship or establishment but, if this is not possible, application should be made to the nearest Railway Transport Officer.

4. AAF T12 is printed in books containing 50 forms in duplicate. While not in use, the books are to be kept under lock and key.

5. Present stocks of this form do not include the certificate (see Appendix 1) in connexion with travel to a member's home on interstate journeys, but the stipulation in the *pro forma* regarding interstate travel is to be observed and the certificate written in until existing supplies are exhausted. New issues will include this certificate.

6. The following instructions are to be observed:—

(a) An AAF T12 will be issued only by an Officer or Rail Transport Officer.

(b) One form is required for each ticket the member wishes to purchase.

(c) Before issuing an AAF T12 the Officer or Rail Transport Officer will—

(i) inspect the member's leave pass;

(ii) satisfy himself, as far as practicable, that the member is validly on leave and is entitled to make the journey for which the AAF T12 is requested;

(iii) complete the AAF T12 by entering thereon particulars of the member, the times within which the travel is authorized and the destination;

(iv) sign and date the AAF T12 over the imprint of a rubber stamp indicating the issuing unit;

(v) ensure that all entries are legibly written in ink or indelible pencil and that a clear and legible carbon copy is made on the duplicate.

(d) The duplicate copy of each AAF T12 will be left in the book which, when complete, will be endorsed on the cover with the designation of the Authority and the period covered. Completed books are then to be forwarded to the issuing Authority.

7. Naval Officers-in-Charge are to act as Central Authority for the distribution of these books of forms which can be obtained from:—

Queensland—

Queensland L. of C. Area,
Stationery Depot,
Stanley-street,
South Brisbane.

New South Wales—

New South Wales L. of C. Area,
Stationery Depot,
C/r. Mary and Reservoir streets,
Sydney.

Victoria—

D.F.O. Headquarters,
Victoria L. of C. Area,
339 Swanston-street,
Melbourne, C.1.

Tasmania—

D.F.O. Headquarters,
Tasmania L. of C. Area,
Anglesea Barracks,
Hobart.

South Australia—

D.F.O. Headquarters,
South Australia L. of C. Area,
Keswick Barracks,
Adelaide.

Western Australia—

D.F.O. Western Command,
Swan Barracks,
Perth.

8. Navy Order 348 of 1944 is cancelled.

AAF T12.

APPENDIX I.

RAILWAY TRAVEL CERTIFICATE.

This is Neither a Leave Pass nor a Priority Permit Authorizing Interstate Travel.

This is to certify that No..... Rank.....
Name..... has been granted permission
between the time following, viz..... hours on.....
to..... hours on..... to proceed from.....
to..... in the State of

.....
Signature of Certifying Officer.

.....
Unit Stamp.

When interstate travel is desired, this form is to be issued to the member only when journeying to his or her home, in which case the following certificate is to be given:—

The above-mentioned member, who is travelling interstate, is travelling to his or her home at..... in the State of.....

.....
Signature of Certifying Officer.

.....
Unit Stamp.

This certificate does NOT cover free travel. Before travel is commenced, this certificate is to be presented at a railway booking office to obtain a ticket at the concession fare available to service personnel travelling in uniform and paying their own fares.

FOR RAILWAY USE ONLY.

This certificate will be retained by the Booking Clerk, who will insert particulars of ticket issued—

From..... To..... First ticket No.....
Second

Fare paid..... Date.....

(632/201/164.)

(This Order will be reprinted for posting on Notice Boards.)

644.

ENGAGEMENT OF SERVICE PERSONNEL IN THE POLICE FORCES.

Positions in the Police Force are open to suitable persons who intend making service in the Police Force a career. Applications from Service personnel who wish to join the Police Force after the war or after normal discharge, should be made now to the Commissioner of Police for the State in which service is desired.

(437/201/818.)

(This Order will be reprinted for posting on Notice Boards.)

645.

ACTION RATIONS.

Stocks of a concentrated ration for consumption at action stations are now available at Royal Edward Victualling Yard, Sydney, and at the Victualling Depot at Fremantle, Melbourne and Brisbane. The ration will be known as "action ration".

2. The action ration is packed in an air-tight metal container measuring $2\frac{1}{2}$ in. x $2\frac{1}{2}$ in. x $\frac{3}{4}$ in., which can conveniently be carried in a pocket and consists of—

- 6 pieces of Caramel.
- 3 pieces of Barley Sugar.
- 6 pieces of Chewing Gum.

The action ration is to be regarded as sufficient for one day; it is supplementary and is not intended to replace any food obtainable from the galley.

3. Supply of action ration will be restricted to the following classes of ships, which are to carry stock sufficient to provide for three rations for each member of the complement:—

- Cruisers.
- Destroyers.
- Landing Ships.
- Vessels employed on long distance escort work.

4. Initial requirements are to be demanded by ships concerned from the nearest Victualling Yard or Depot indicated in paragraph 1.

5. Action rations are to be taken on charge in "tins" in the Provision Account and issues on each occasion are to be supported by the certificate of the Commanding Officer that circumstances necessitated the expenditure.

(668/201/2684.)

By Authority: H. E. DAW, Government Printer, Melbourne.

RESTRICTED.(FOR OFFICIAL USE ONLY.)**Commonwealth Navy Orders.**

Navy Office, Melbourne,
12th December. 1944.

The following Orders, having been approved, are hereby promulgated for information and guidance, and necessary action.

By direction of the Naval Board,

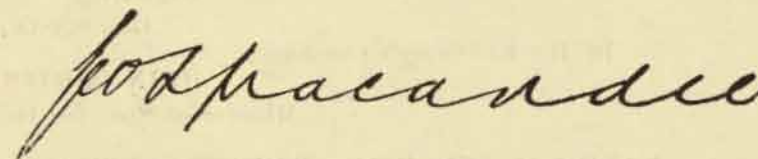

Secretary.

*The Commodore Commanding H.M.A. Squadron,
and Commanding Officers of H.M.A. Ships,
Officers in Charge of H.M.A. Naval
Establishments, and others concerned.*

TABLE OF CONTENTS.

No.	Subject.
646.	Women's Services—R.A.N.—Statutory Rules Governing Administration of.
647.	Senior Naval Officer, Beach Unit.
648.	Accountant Branch Examinations.
649.	Advancement of Ratings Trained in Combined Operations.
650.	Retention of Acting Higher Rank.
651.	Naval Censorship.
652.	Coastal Craft Section—Formation.
653.	Bofors 40 mm. Ammunition—Policy in Regard to Issue.
654.	Primers D.C. Marks VII and VIII and Type "M".
655.	Quarterly Return of Dental Work.
656.	Naval Storekeeping Ledgers—Rearrangement.
657.	Officers' Mess Traps—Replacement Allowances Applicable for 1944-45.
658.	Fresh Water Supplies to H.M.A. Ships.
659.	Disposal of Travelling and Freight Warrant Books.
660.	Supply of Greatcoats for Naval Chaplains.
661.	Gratuitous Issues of Uniform Clothing to British and Allied Services.
662.	Shoes, Gymnastic—Introduction of Substitute Pattern.
663.	Victualling Stores—Demands for.
664.	Fire Fighting School.
665.	Mess Utensils for Chief Petty Officers', Petty Officers' and Seamen's Messes—Replacement Allowances for 1944-45.

C.13023/44

646.

WOMEN'S SERVICES—R.A.N.—STATUTORY RULES GOVERNING ADMINISTRATION OF.

The Naval Forces (Women's Services) Regulations were recently amended by Statutory Rules 1944/155. The regulations as amended to date and the National Security (Women's Services) Regulations are reprinted hereunder.

2. Navy Order 10 of 1944 is hereby cancelled.

(a) STATUTORY RULES 1943, No. 66.

REGULATIONS UNDER THE NATIONAL SECURITY ACT 1939-1940.*

I, the Governor-General in and over the Commonwealth of Australia, acting with the advice of the Federal Executive Council, hereby make the following Regulations under the *National Security Act 1939-1940*.

Dated this twenty-third day of March, 1943.

GOWRIE,

Governor-General.

By His Excellency's Command,

JOHN CURTIN,

Minister of State for Defence.

NATIONAL SECURITY (WOMEN'S SERVICES) REGULATIONS.

1. These Regulations may be cited as the National Security (Women's Services) Regulations.

2. These Regulations shall be administered by the Minister of State for Defence.

3. (1) In these Regulations, "Women's Service" means any Women's Service constituted under the Naval Forces (Women's Services) Regulations, the Military Forces (Women's Services) Regulations or the Air Force (Women's Services) Regulations.

(2) Unless the contrary intention appears, words used in these Regulations shall have the same meaning as in the *Defence Act 1903-1941*.

4. Notwithstanding anything contained in the *Defence Act 1903-1941*, the *Naval Defence Act 1910-1934*, the *Air Force Act 1923-1941*, any regulation made under any of those Acts, or any Imperial Act, rule or regulation which by any of those Acts or regulations made thereunder is applied to the Defence Force or any part or members thereof, a member of a Women's Service shall not—

(a) have a right to elect to be tried or be liable to trial by court-martial for any offence; or

(b) be eligible to sit or otherwise act as a member of a court-martial.

5. (1) A member of a Women's Service which forms part of the Naval Forces shall not do any act or be guilty of any conduct which, by sections 3 to 16 (both inclusive), 19, 20, 21, 25, 26, 29, 33, 34 and 35 of the Imperial Act called the Naval Discipline Act, is proscribed to be an offence or to be punishable under that Act.

* Notified in the *Commonwealth Gazette* on 24th March, 1943.

(2) A member of a Women's Service which forms part of the Military Forces or the Air Force shall not do any act or be guilty of any conduct which, by sections 4, 5, 6, 7, 12, 14, 17, 23, 24, 25, 35 and 36 of the Army Act or the Air Force Act, as the case may be, is proscribed to be an offence or to be punishable under that Act.

6. A member of a Women's Service who has been acquitted or convicted of a breach of these Regulations or any other offence against the *National Security Act 1939-1940* shall not be punished summarily under the *Defence Act 1903-1941*, the *Naval Defence Act 1910-1934*, the *Air Force Act 1923-1941*, or any regulations made under any of those Acts, for the same offence:

Prohibition of civil punishment for the same offence.

Provided that nothing in this regulation shall prevent the dismissal or discharge from the Defence Force of any member convicted of any such offence.

7. Notwithstanding anything contained in the *Naval Defence Act 1910-1934*, a member of a Women's Service which forms part of the Naval Forces who is appointed or enlisted for service within the limits of Australia only shall not be required to serve beyond those limits unless she voluntarily agrees so to serve.

Limits of service of members of the Naval Forces.

(b) STATUTORY RULES 1943, No. 67.

REGULATIONS UNDER THE NAVAL DEFENCE ACT 1910-1934.*

I, the Governor-General in and over the Commonwealth of Australia, acting with the advice of the Federal Executive Council, hereby make the following Regulations under the *Naval Defence Act 1910-1934*.

Dated this twenty-third day of March, 1943.

GOWRIE,

Governor-General.

By His Excellency's Command,

NORMAN J. O. MAKIN,

Minister of State for the Navy.

NAVAL FORCES (WOMEN'S SERVICES) REGULATIONS.

PART I.—INTRODUCTORY.

1. (1) These Regulations may be cited as the Naval Forces (Women's Services) Regulations.

Citation and Administration.

(2) These Regulations shall be administered by the Minister of State for the Navy.

2. These Regulations are divided into Parts, as follows:—

Parts.

Part I.—Introductory.

Part II.—Royal Australian Naval Nursing Service.

Part III.—Women's Royal Australian Naval Service.

Part IV.—Discipline.

Part V.—General.

* Notified in the *Commonwealth Gazette* on 24th March, 1943.

Definitions.

3. In these Regulations, unless the contrary intention appears—

“Director of Naval Medical Services” means the officer appointed by the Naval Board to administer the Medical Services of the Royal Australian Navy;

“member” means a woman appointed to or enlisted in a Women’s Service under these Regulations;

“officer” means any member other than an enlisted member;

“rating” means an enlisted member;

“Women’s Service” means one of the Services specified in Regulation 4 of these Regulations.

Establishment of Women’s Services.

4. There shall be the following Services, composed of women, appointed or enlisted in accordance with these Regulations, which shall form part of the Naval Forces:—

The Royal Australian Naval Nursing Service.

The Women’s Royal Australian Naval Service.

PART II.—ROYAL AUSTRALIAN NAVAL NURSING SERVICE.

Constitution.

5. The Royal Australian Naval Nursing Service shall consist of officers appointed to that Service for the performance of such duties in connexion with nursing of members of the Naval Forces as the Naval Board determines.

Appointments.

6. The Minister may, on the recommendation of the Naval Board, recommend to the Governor-General suitable candidates for appointment as officers of the Royal Australian Naval Nursing Service.

Reserve List (Inserted by S.R. 1943/201.)

6A. An officer, appointed to the Royal Australian Naval Nursing Service and awaiting allotment to duty, may be placed on a Reserve List, and whilst on the Reserve List shall not be entitled to any pay or allowances.

Eligibility.

7. A woman may be appointed an officer of the Royal Australian Naval Nursing Service, if she—

(a) is not less than twenty-one or more than forty-five years of age;

(b) has passed such medical examination as is approved by the Naval Board; and

(c) (i) is a nurse registered as such under the provisions of any law of the Commonwealth or of any State or Territory of the Commonwealth, and has had not less than three years’ service and training in medical and surgical nursing in a hospital approved by the Director of Naval Medical Services; or

(ii) possesses such scientific qualifications as are approved by the Naval Board.

Provided that a woman who is more than forty-five years of age may be appointed as a Matron or Superintending Sister, if the Naval Board certifies that she has special qualifications or that it considers that special circumstances warrant her appointment.

8. The grades of officers of the Royal Australian Naval Nursing Service shall be those set out in the first column of the following table and, for the purpose of determining relative rank, they shall correspond with the ranks of male officers of the Naval Forces specified opposite thereto respectively in the second column of the table:—

Matron	Lieutenant-Commander.	(Amended by S.R. 1944/155.)
Superintending Sister	Lieutenant.	
Sister or Staff Officer	Sub-Lieutenant.	

9. An officer of the Royal Australian Naval Nursing Service may be promoted to a higher grade if—

(a) a vacancy in the higher grade exists in the authorized establishment; and

(b) she is selected for promotion to the vacancy by the Naval Board upon a recommendation by the Director of Naval Medical Services.

10. In a Naval hospital and in its vicinity, a member of the Royal Australian Naval Nursing Service shall, in matters of medical service, have authority next after officers of the Medical Branch of the Royal Australian Navy and shall at all times be obeyed accordingly.

11. Members of the Royal Australian Naval Nursing Service shall be under the command of the Commanding Officer of the Establishment to which they are attached, but the control of the nursing staff shall be the responsibility of the Matron, or if there is no Matron in charge for the time being, the Superintending Sister.

PART III.—WOMEN’S ROYAL AUSTRALIAN NAVAL SERVICE.

12. The Women’s Royal Australian Naval Service shall consist of female officers and ratings appointed to, or enlisted in, that Service for the performance of such duties in relation to the Naval Forces as the Naval Board determines.

13. The Minister may, on the recommendation of the Naval Board, recommend to the Governor-General suitable candidates for appointment as officers of the Women’s Royal Australian Naval Service.

14. A woman shall be eligible for appointment to, or enlistment in, the Women’s Royal Australian Naval Service, if she has—

(a) attained the age of eighteen years, but has not attained the age of forty years; and

(b) passed such medical examination as is approved by the Naval Board:

Provided that a woman who has attained the age of forty years, but has not attained the age of fifty years, may be appointed to, or enlisted in, the Women’s Royal Australian Naval Service, if the Naval Board certifies that she has special qualifications or that it considers that special circumstances warrant her appointment or enlistment.

15. Ratings of the Women’s Royal Australian Naval Service shall be enlisted for the period of the duration of the war and six months thereafter or two years, whichever period is the greater.

Period of enlistment.

Ranks of officers.

16. The ranks of officers in the Women's Royal Australian Naval Service shall be those set out in the first column of the following table, and, for the purposes of determining relative rank, they shall correspond with the ranks of male officers of the Naval Forces specified opposite thereto in the second column of that table:—

Chief Officer	Commander.
First Officer	Lieutenant-Commander.
Second Officer	Lieutenant.
Third Officer	Sub-Lieutenant.
Third Officer (on probation)			Acting Sub-Lieutenant.

Ratings.

17. The ratings of women enlisted in the Women's Royal Australian Naval Service shall be those set out in the first column of the following table, and, for the purpose of determining relative rating, they shall correspond with the ratings of men of the Naval Forces specified opposite thereto in the second column of that table:—

Wran	Able Seaman.
Leading Wran	Leading Seaman.
Petty Officer Wran	Petty Officer.
Chief Petty Officer Wran	Chief Petty Officer.

Rating upon entry.

18. Women may be entered with such rating as the Naval Board, having regard to the qualifications of the candidates and the vacancies in the authorized establishments, approves.

Promotion and advancement

19. (1) An officer may be promoted to a higher grade, if she is recommended for promotion by the Naval Board and a vacancy in that grade exists in the authorized establishment.

(2) The Naval Board may advance any servicewoman to a higher rating, if she is recommended for advancement by her Commanding Officer, or possesses special qualifications for advancement to that rating, and a vacancy in that rating exists in the authorized establishment.

Discharge.

20. The Naval Board may for any reason discharge a rating from the Women's Royal Australian Naval Service at any time.

Command.

21. An officer or rating of the Women's Royal Australian Naval Service shall not exercise command over any person other than members of the Women's Royal Australian Naval Service or members of the Naval Forces detailed or attached for duty under her command and inferior in rank or rating to herself.

PART IV.—DISCIPLINE.

Disposal of charges summarily.

22. (1) Subject to these Regulations, any officer of the Naval Forces who is authorized to deal summarily with a charge against a member of the Naval Forces of having committed any offence may, if he finds a member of a Women's Service guilty of an offence, award to her any one or more of the following punishments:—

- (i) disrating or reduction to the ranks;
- (ii) deprivation of good conduct badges;
- (iii) a fine not exceeding Five pounds or forfeiture of all ordinary pay for a period not exceeding fourteen days;
- (iv) extra duties for a period not exceeding fourteen days;
- (v) stoppage of leave for a period not exceeding fourteen days;

- (vi) reprimand;
- (vii) any deduction from ordinary pay which he may lawfully order to be made in respect of the offence of which the member has been found guilty,

but no other punishment.

(2) Any officer authorized to deal summarily with a charge against a member of a Women's Service may, as to any member found by him to be guilty of an offence—

- (a) in addition to, or in lieu of awarding any of the punishments specified in sub-regulation (1) of that regulation if he considers the offence or the circumstances in which it was committed to be of such a nature as to warrant, recommend that she be dismissed or discharged; or
- (b) if he considers that she has committed an offence under the *National Security Act 1939-1940*, adjourn the case and take the necessary steps for her prosecution for that offence.

(Amended by S.R. 1944/101.)

(3) Where a recommendation that a member of a Women's Service be dismissed or discharged is made in pursuance of sub-regulation (2) of this Regulation, an authority having power to dismiss or discharge the member may, in lieu of giving effect to the recommendation, in addition to any punishment already awarded her by the officer making the recommendation, award her any one or more of the other punishments specified in sub-regulation (1) of this Regulation.

(4) When any investigation is held into a disciplinary offence committed by a member of the Women's Royal Australian Naval Service employed in any Naval Establishment, an Officer of the Women's Royal Australian Naval Service employed at the Naval Establishment shall be present.

(Inserted by S.R. 1944/101.)

(5) An officer in command of a Naval Establishment may, in writing, delegate the power of dealing summarily with a minor offence committed by a rating of the Women's Royal Australian Naval Service to an officer of the Women's Royal Australian Naval Service not below the rank of Second Officer, who may award up to a maximum of seven days of either or both of the following punishments:—

Inserted by S.R. 1944/101.)

- (i) extra duties; or
- (ii) stoppage of leave.

(6) If an Officer authorized to deal summarily with a charge against a member of a Women's Service considers the offence charged or the circumstances in which it is alleged to have been committed to be of such a nature as to warrant her discharge or dismissal, if convicted, or her prosecution under the *National Security Act 1939-1943*, he shall, in either case, cause the evidence to be reduced to writing and shall arrange for the services of an officer of the Naval Forces or of the Women's Royal Australian Naval Service to be made available to assist the accused member in stating her case.

Inserted by S.R. 1944/101.)

23. A member under close arrest and awaiting the disposal of a charge against her shall be guarded by female guards unless female guards are unavailable.

Guarding of members in custody

PART V.—GENERAL.

24. Leave of absence may be granted to members for such periods and upon such conditions as the Naval Board, from time to time, directs.

†24A. (1) Subject to the provisions of the next succeeding sub-regulation, where a member of a Women's Service is granted leave without pay, the period of leave shall count as part of the member's period of service, but it shall not count—

- (a) towards seniority for promotion;
- (b) towards increment of pay; or
- (c) towards the requisite qualifying time for eligibility for credit of deferred pay.

(2) A rating under 21 years of age shall be permitted to count periods of leave without pay towards the requisite qualifying time for increased rate of active pay:

Provided that, where any continuous period of leave so granted exceeds two calendar months, the period in excess of two months shall not be permitted to count.

25. The uniform to be worn by members shall be as approved by the Naval Board.

26. The Naval Forces Regulations for the time being in force shall, subject to such modifications and adaptations as are expressly provided or necessarily implied by these Regulations, apply to and in relation to any Women's Service and the members thereof.

† This regulation shall be deemed to have come into operation on and from the second day of February, 1944.

647.

SENIOR NAVAL OFFICER, BEACH UNIT.

With reference to Navy Order 513 of 1944, the Naval Beach Organization will in future be known as "R.A.N. Beach Unit" (Short title R.A.N.B.U.).

2. The title of the Senior Officer is altered from "Senior Naval Officer, Combined Operations Section" (S.N.O.C.O.S.) to "Senior Naval Officer, Beach Unit" (S.N.O.B.U.).

(463/205/5821.)

648.

ACCOUNTANT BRANCH EXAMINATIONS.

The provisions of Admiralty Fleet Orders 2703 and 2704 of 1944, in regard to examinations for the rank of Paymaster Lieutenant-Commander and Paymaster Sub-Lieutenant, will be adopted as far as practicable in the Royal Australian Navy.

(559/215/1659.)

649

ADVANCEMENT OF RATINGS TRAINED IN COMBINED OPERATIONS.

The following conditions of service have been approved for ratings entered for, and serving in, the Combined Operations Organization.

2. Ordinary seamen required for combined operations training will be selected from ordinary seamen who have completed one month's disciplinary course at Flinders Naval Depot and will then be appropriated to combined operations camp as required. In view of the disadvantage to which these ratings will be subjected as compared with ordinary seamen who complete the full new entry course at Flinders Naval Depot, and thus have the opportunity of gaining one month both in seamanship and gunnery, *vide* Navy Order 355 of 1941, the Naval Board have approved of the following conditions of advancement to able seamen or ordinary seamen selected for combined operations training:—

- (a) On completion of the combined operations training course of two months, ordinary seamen may gain up to two months' time on examination in combined operations courses which include seamanship, boat work, small arms training, pilotage, and signals, according to the scale:—
 - 85 per cent. and over (V.G.I.)—two months.
 - 75 per cent.—84 per cent. (V.G.)—one month.
 - 74 per cent. and below—nil.
- (b) Twelve months' service as ordinary seaman including four months' sea service minus any time gained in accordance with (a). In exceptional cases, Commanding Officers may reduce the necessary service of an ordinary seaman to eleven, ten, or a minimum of nine months (in addition to time gained as at (a)) thus making possible a minimum of seven months' service. The due dates for advancement in all cases are to be reckoned from the commencing date of service as ordinary seaman.
- (c) An ordinary seaman who has not completed four months' sea service, including time allowed under paragraph 4, is only eligible to be advanced to acting able seaman on the completion of twelve months' service as an ordinary seaman. Confirmation and antedating in respect of time gained in accordance with (a) and (b) may be effected, however, on completion of four months' sea service.
- (d) Ordinary seamen, who may be returned to general service before completion of the two months' course referred to in (a) above, will be subject to general service conditions of advancement. A maximum of one month's seniority for seamanship and one month for gunnery is to be awarded by the Commanding Officer of the next sea-going ship under same conditions as if courses were completed in depot. Similarly, ordinary seaman returned to general service after completion of training will be subject to general service conditions of advancement, unless such return was due to causes outside the rating's own control, in which case particulars should be reported to the Naval Board for decision.

3. Vacancies for leading seaman, leading stoker, petty officer and stoker petty officer will be filled from personnel serving within the Combined Operations Organization, and will be subject to the following conditions:—

To Leading Seaman and Leading Stoker—

- (a) Authority of Naval Officer-in-Charge, Flinders Naval Depot.
- (b) Vacancies in fleet numbers of combined operations organization.
- (c) Recommendation on Form A.S. 507. (Owing to limited opportunities for confirmation, a Form A.S. 507 may be rendered for acting able seamen).
- (d) No professional or time qualification.
- (e) Advancement to be in the provisional acting temporary rating.
- (f) Acting provisional temporary rating to be held only while serving in Combined Operations Organization, including period up to 30 days whilst in hospital or on sick leave; ratings reverted to general service revert to the last confirmed substantive rating held.

To Petty Officer and Stoker Petty Officer—

- (a) As for leading seaman and leading stoker.
- (b) Vacancy in fleet numbers of combined operations organization.
- (c) Authority of the Naval Officer-in-Charge, Flinders Naval Depot.
- (d) Recommendation on Form A.S. 507. Recommendations are to include particulars of any civil employment or hobbies which may have contributed to the efficiency of the rating.
- (e) Advancement to be in the provisional acting temporary rating.
- (f) Acting provisional temporary rating to be held only while serving in combined operations organization including period up to 30 days whilst in hospital or on sick leave; ratings reverted to general service revert to the last confirmed rating held.

4. Combined operations ratings on shore abroad may count their shore service as sea time for advancement purposes, but other qualifications of a professional nature (whether examinations or certificates) may not be waived in connection with general service advancement.

5. On completion of combined operations courses, a return of the results of the examinations is to be rendered to the Director of Navy Accounts and the Naval Officer-in-Charge, Flinders Naval Depot, setting out the percentages in various subjects and time gained by each rating. Names of ratings reverted to general service should also be indicated on this return.

6. Navy Orders 449 of 1943 and 221 and 292 of 1944 are cancelled.

(568/202/1008.)

(This Order will be reprinted for posting on Notice Boards.)

650.

RETENTION OF ACTING HIGHER RANK.

The provisions of A.F.O. 4694/44 have been adopted in the Royal Australian Navy as from 1st November, 1944.

(578/201/234.)

651.

NAVAL CENSORSHIP.

With reference to Navy Order 23 of 1944, paragraph 20, the following sub-paragraph is to be added:—

“(vii) Use of any form of code whether in the shape of letters, figures, signs, symbols or plain language.”

(1835/2/534.)

652.

COASTAL CRAFT SECTION—FORMATION.

The Naval Board have approved of the formation of a Coastal Craft Section of the R.A.N. for administration and drafting purposes.

2. The following vessels will be included in this Section:—

Fairmile Motor Launches,
Harbour Defence Motor Launches,
Naval Auxiliary Patrol Craft,
Air Sea Rescue Launches,

and other local vessels which are manned by Flinders Naval Depot drafting. A list of the names of craft which comprise the Coastal Craft Section is attached to this Order. Amendments to this list will be promulgated as necessary to include new construction and other changes.

3. Personnel of this Section will be General Service Personnel.

4. Coastal Craft will be administered by the Local Naval Officer-in-Charge and an officer will be appointed to each Base as Staff Officer (Coastal Craft).

5. Accounts will be carried in the naval depot of the base to which the vessels are allocated.

6. Maintenance of vessels of the Coastal Craft Section will be the responsibility of the base engineer officer at each base.

COASTAL CRAFT.

A.	<i>Amohine</i>	<i>Air Speed</i>
	<i>Air Bird</i>	<i>Air Spray</i>
	<i>Air Chief</i>	<i>Air Trail</i>
	<i>Air Clan</i>	<i>Air View</i>
	<i>Air Cloud</i>	<i>Air Watch</i>
	<i>Air Faith</i>	<i>Air Wave</i>
	<i>Air Hope</i>	<i>Arthur Rose</i>
	<i>Air Host</i>	<i>Ambon</i>
	<i>Air Master</i>	<i>Alatna</i>
	<i>Air Mercy</i>	<i>Apache</i>
	<i>Air Mist</i>	<i>Angler</i>
	<i>Air Rest</i>	<i>Alexander Thomson</i>
	<i>Air Sailor</i>	<i>Arcadia</i>
	<i>Air Save</i>	<i>Avonita</i>
	<i>Air Sense</i>	<i>Avalon</i>
B.	<i>Boonooroo</i>	<i>Boroughbelle</i>
	<i>Betty Too</i>	<i>Black Snake</i>
	<i>Banyanda</i>	
C.	<i>Catherine R.</i>	<i>Coongoola</i>
	<i>Chinampa</i>	
D.		
E.	<i>Ellan</i>	<i>Esmeralda</i>
F.	<i>Fauro Chief</i>	<i>Flying Cloud</i>
	<i>Faye C</i>	
G.	<i>Gumleaf</i>	<i>Griffioen</i>
	<i>Gloria</i>	<i>Grelka</i>
H.	<i>Hiawatha</i>	
I.	<i>Iris</i>	
J.	<i>John Hardy</i>	<i>James Innes</i>
	<i>Jane</i>	
K.	<i>Killearn</i>	<i>Krait</i>
	<i>Keith Cam</i>	<i>Koorine</i>
	<i>Kazembe</i>	<i>Kweena</i>
	<i>Kuru</i>	<i>Kimra</i>
	<i>Kiara</i>	
L.	<i>Ladava</i>	<i>Larrakia</i>
	<i>Lolita</i>	<i>Lauriana</i>
	<i>Leilani</i>	<i>Lucy Star</i>
	<i>Laurabada</i>	<i>Lorne</i>
	<i>Lysander</i>	<i>Lancelin</i>

COASTAL CRAFT—continued.

M.	<i>Mowong</i>	M.L. 424	812	M.L. (H.D.)	1074
	<i>Martindale</i>	425	813		1129
	<i>Motor Water Lighters</i>	426	814		1161
	<i>Moruya</i>	427	815		1321
	<i>Miss Swan</i>	428	816		1322
	<i>Melville</i>	429	817		1323
	<i>Malanda</i>		818		1324
	<i>Motor Refrigerator Lighters</i>	431	819		1325
	<i>Maringo</i>	801	820		1326
	<i>Miss Gladys</i>	802	821		1327
	<i>Marlean</i>	803	822		1328
	<i>Miramar</i>	804	823		1329
	<i>Mischief</i>	805	824		1338
	<i>Marynong</i>	806	825		1339
	<i>Marietta</i>	807	826		1340
	<i>Marina</i>	808	827		1341
	<i>Margaret II</i>	809			1342
	<i>Mandurah</i>	810			1343
	<i>Melton Lass</i>	811			1344
					1345
					1346
					1347
					1352
					1353
					1354
					1355
					1356
					1357
					1358
					1359
N.	<i>Nepean</i>			<i>Nokomis</i>	
	<i>Nitipa</i>			<i>Nyroca</i>	
	<i>Nilram</i>				
O.	<i>Oil Fuel Lighters (1,200 tons)</i>				
	<i>Oenone</i>				
P.	<i>Paluma</i>			<i>Peterpan</i>	
	<i>Para</i>			<i>Pinafore</i>	
Q.					
R.	<i>Red Bill</i>			<i>Rathane</i>	
	<i>Radical</i>			<i>Reverie</i>	
S.	<i>Stingray</i>			<i>San Michele</i>	
	<i>Seabird</i>			<i>Shark</i>	
	<i>Seeka</i>			<i>Saggitas</i>	
	<i>Sea Mist</i>			<i>Spinnaway</i>	
	<i>Steady Hour</i>			<i>Seafarer</i>	
				<i>Sea Snake</i>	

COASTAL CRAFT—*continued.*

T.	<i>Three Cheers</i> <i>Tangalooma</i> <i>Tropic Bird</i> <i>Toomeree</i>	<i>Tiger Snake</i> <i>Tipton</i> <i>Temeraire</i>
U.		
V.	<i>Viking</i>	<i>Vlaming</i>
W.	<i>Wimbah</i> <i>Wairere</i> <i>Westwind</i>	<i>Wongalere</i> <i>Wai Marie</i> <i>Winnilya</i>
X.		
Y.	<i>Yarroma</i>	
Z.	<i>Zanana</i>	

(1937/2/249.)

653.

BOFORS 40 MM. AMMUNITION—POLICY IN REGARD TO ISSUE.

The following policy is to be observed in regard to the issue of Bofors ammunition:—

	<i>Manufacture.</i>	<i>Issue to—</i>
(a)	British, to Naval designs ..	All ships. Not to be issued to D.E.M.S. if other ammunition is available.
(b)	British, to Land Service designs, and Canadian, to British Land Service designs	D.E.M.S. Only to be issued to warships if ammunition at (a) or (c) is not available.
(c)	U.S.A.	All ships. Not to be issued to D.E.M.S. if other ammunition is available.
(d)	Australian to Land Service designs	D.E.M.S. To be issued to warships only if ammunition at (a) or (c) is not available.

2. All previous instructions in regard to issue of Bofors ammunition are hereby cancelled.

(408/206/1472.)

654.

PRIMERS D.C. MARKS VII AND VIII AND TYPE "M".

All primers D.C. Marks VII and VIII and type "M" filled M.E. during the years 1942, 1943, 1944, and Mark VII primers lots 532 and 533 H and H filled 9/42 and Mark VIII H and H filled 6/41, are to be returned to the nearest Naval Armament Depot, and replacements which have passed D.O.T.M. gauge 1826 drawn in lieu.

(471/205/2294.)

655.

QUARTERLY RETURN OF DENTAL WORK.

It is desired in future that, in lieu of the Annual Dental Return required by C.O.R., Article 584, clause 3, a quarterly Dental Return on Form A.M. 235z, suitably amended, be forwarded to the Senior Dental Surgeon, R.A.N., Naval Medical Branch, Navy Office, Melbourne.

2. This Return should be completed on the last day of the months of March, June, September, and December.

3. If adverse conditions or extraordinary circumstances prevail, a notation of the number of days lost should be appended in the remarks column.

4. The Dental Officers in forward areas are to give first priority to small ships requesting dental attention, even at the expense of their own ship's company, who have facilities available at all times.

5. The Day Book A.M. 202z is not to be forwarded unless requested.

6. C.O.R., Article 584, clause 3, is being amended accordingly.

(527/210/4045.)

656.

NAVAL STOREKEEPING LEDGERS—RE-ARRANGEMENT.

With reference to A.F.O. 3195/44, the following procedure is to apply in regard to the re-arrangement of Naval Store Ledger pages in H.M.A. ships and establishments in which the standard naval store-keeping system in accordance with the Naval Storekeeping Manual B.R.4 is applicable:—

- (a) In future, naval store accounts for new construction ships will be prepared in numerical order, of pattern numbers within each sub-head of the rate book of naval stores, and ledger pages for all items to which a pattern number has not been allocated included in the sub-head will be arranged alphabetically at the end of each sub-head. The ledger pages will be numbered, and Ledger Certificates completed and inserted in each ledger binder by the appropriate (Superintending) Naval Store Officer, as hitherto.

(b) In H.M.A. ships and establishments in which the standard naval storekeeping system is at present in operation, the re-arrangement of existing ledger pages will not normally be effected until it is necessary for any reason to close existing ledgers and open new ledgers. In such cases an Assistant Inspecting Officer (N.S.) will be made available when possible to advise in regard to the new arrangements. It is pointed out that re-arrangement of existing accounts involves in addition to the alteration of existing ledger page numbers, the alteration of the page numbers shown in other records, e.g., permanent loan lists, record of stowage, stocktaking books, &c.

(c) The existing R.A.N. procedure in regard to the numbering of ledger pages, as set out in paragraph 62 of the R.A.N. Supplement to B.R.4, is to remain in force.

(612/212/3101.)

657.

OFFICERS' MESS TRAPS—REPLACEMENT ALLOWANCES APPLICABLE FOR 1944-45.

With reference to C.O.R., Article 488, the amounts to which free replacements may be made during the year ending 30th June, 1945, of items of officers' mess traps included in the consumable sections of the scales shown in A.F.O. 94/42, and of articles in the permanent sections of those scales which are marked with an asterisk are:—

Mess.	In Stationary Ships and Shore Establishments.	In Sea-going Ships.
	£ s. d.	£ s. d.
Flag Officer	12 7 6	21 10 0
Commodore or Captain	12 7 6	14 15 0
Flag Captain, Commander or Lieutenant-Commander in Command	8 5 0	10 5 0
Ward Room—		
Mess of one officer	3 1 0	3 13 0
Mess of two officers	5 3 6	6 5 0
For every officer permanently borne in excess of two ..	0 14 6	1 2 6
Gun Room—		
Mess of one officer	2 16 6	3 8 0
To every officer permanently borne in excess of one ..	0 14 0	1 1 6
Warrant Officers—		
Mess of one officer	3 6 6	4 0 0
To every officer permanently borne in excess of one ..	0 11 0	0 17 6

2. All consumable stores drawn against these allowances are to be valued at the Admiralty Victualling Rate Book Prices for 1944/45.

3. Where officers are borne supernumerary to complement for training, &c., the replacement allowances for such officers are to be calculated on the basis of the average daily numbers borne during each quarter.

4. When calculating replacement allowances, officers on permanent lodging and provision allowances are to be excluded.

(407/201/839.)

658.

FRESH WATER SUPPLIES TO H.M.A SHIPS.

In connection with the supply of fresh water to H.M.A. ships at Australian ports, which is the specific responsibility of the Naval Officer-in-Charge of the port concerned, it has been decided that in future such supplies are not in any manner to form part of the duties of a naval store establishment or a victualling store establishment which may be in the port.

2. In accordance with this principle, the watering craft *Ripple*, water lighters, and civil crews formerly operating from Royal Edward Victualling Yard, Sydney, have recently been transferred to Garden Island for duty under the control of the master attendant.

3. It has also been decided that accounting for fresh water supplies in the naval store accounts of H.M.A. ships is no longer necessary, as the usual entries in the engine-room register of each ship will be accepted in future as the official record of quantities received for all purposes, including the verification of claims for payment for such supplies.

4. C.O.R., Article 522, is cancelled, and the R.A.N. Supplement to B.R.4, Naval Storekeeping Manual, will be appropriately amended in due course.

(646/201/262.)

659.

DISPOSAL OF TRAVELLING AND FREIGHT WARRANT BOOKS.

With reference to Naval Account Regulations and Instructions, Article 322 (2), the under-mentioned warrant, &c., books, when completed, should be returned to the Director of Navy Accounts by H.M.A. ships whose travelling and freight accounts are paid by Navy Office in accordance with Naval Account Regulations and Instructions, Article 321 (1):—

Duty Rail Warrants;
Leave Concession Warrants;
Excess Luggage Warrants;
Orders for Car Hire (A.S.559X);
Chargeable Railway Warrants;
Steamer warrants;
Cartage Warrants (A.S.559Y);
Railway Consignment Notes (A.S.559Z).

2. Completed books of these warrants should be retained by shore establishments and offices, and by depot ships which pay or authorize payment of their own warrants, for the period prescribed in Naval Account Regulations and Instructions, Article 372 (1).

3. Suitable notation should be made against Naval Account Regulations and Instructions, Article 322 (2).

(480/205/1154.)

660.

SUPPLY OF GREATCOATS TO NAVAL CHAPLAINS.

Naval chaplains are permitted to wear greatcoats of a pattern similar to that worn by other naval officers with the exception that badges of rank are not worn on shoulder straps.

2. Under the terms of existing agreements arrangements have been made with all outfitters referred to in Navy Order 407 of 1944 for the supply of greatcoats to naval chaplains at the following prices:—

	£	s.	d.
Greatcoats for chaplains, cloth No. 3 ..	6	0	6 each.
Greatcoats for chaplains, beaver cloth* ..	7	6	6 each.

* For chaplains R.A.N. only.

(434/215/1112.)

661.

GRATUITOUS ISSUES OF UNIFORM CLOTHING TO BRITISH AND ALLIED SERVICES.

To facilitate the preparation of necessary claims for recovery of value in respect of gratuitous issues of uniform clothing made to British or Allied personnel, the details of such issues are in future to be shown separately from R.A.N. issues in the appropriate Form A.S.79.

(612/211/3910.)

662.

SHOES, GYMNAS TIC: INTRODUCTION OF SUBSTITUTE PATTERN.

Due to the acute shortage of crude rubber, no further supplies of the normal-type gymnastic shoe, as formerly stocked in the R.A.N., can be procured. A substitute shoe, made with a grey chrome split leather upper and a sole manufactured from scrap rubber tires, has been temporarily adopted in lieu and will be supplied to meet demands on exhaustion of existing stocks of the normal type. The substitute article will also replace rope-soled shoes in future.

2. The new-type shoes, supplies of which are now available will be designated "shoes, gymnastic, substitute pattern," and issues are to be charged at 7s. 10d. per pair, the necessary addition being made to the "Official Memorandum—Prices of Clothing, &c., Maintained for Issue on Repayment to Ships' Companies" dated 1st May, 1944.

(420/201/1100.)

(This Order will be reprinted for posting on Notice Boards.)

663.

VICTUALLING STORES—DEMANDS FOR.

As indicated in Navy Order 342 of 1944, victualling depots for the maintenance and supply of victualling stores to H.M.A. ships and establishments during the present war are located at Brisbane, Fremantle, Port Melbourne, Townsville, and Cairns, being auxiliary supply bases to the Royal Edward Victualling Yard, Sydney, which is still the main source of supply for all descriptions of victualling stores normally stocked.

2. In addition to the supply of the full requirements of local naval establishments, the victualling depots referred to are intended to meet all victualling store requirements of H.M.A. ships based on the port or continuously operating for a period in its vicinity.

3. In the case, however, of Flinders Naval Depot, also other Victorian establishments and Tasmanian and South Australian establishments, demands for dry provisions, mess traps, and mess utensils are only to be lodged with the Victualling Depot, Port Melbourne, uniform and other clothing being obtained by the naval establishment concerned direct from the Royal Edward Yard, as hitherto.

4. Accountant and other demanding officers are carefully to note and observe the foregoing in order that stocks maintained at the several victualling depots may be satisfactorily regulated.

(612/248/1339.)

664.

FIRE FIGHTING SCHOOL.

Commanding Officers of H.M.A. ships and establishments are in future to forward to H.M.A.S. *Penguin* all information concerning the outbreaks of fires and the action taken in subduing them which may be of assistance to the fire fighting and damage control school, Sydney.

(475/201/228.)

665.

MESS UTENSILS FOR CHIEF PETTY OFFICERS', PETTY OFFICERS' AND SEAMEN'S MESSSES—REPLACEMENT ALLOWANCES FOR 1944-45.

With reference to C.O.R., Article 489, the annual amounts to which free replacement of consumable items in the scales of mess utensils laid down in the A.F.O. 94/42 will be allowed for chief petty officers', petty officers', and seaman's messes in H.M.A. ships and establishments for the year ending 30th June, 1945, are as follows:—

(a) Chief petty officers, and petty officers ..	9s. 3d. per head.
(b) All other ratings	7s. 3d. per head.

2. The articles drawn against these allowances are to be valued at the Admiralty Victualling Rate Book prices for 1944-45, with the exception of earthenware mugs, which are to be valued at 9d. each.

(530/202/444.)

RESTRICTED.(FOR OFFICIAL USE ONLY.)

Commonwealth Navy Order.

Navy Office, Melbourne,

19th December, 1944.

The following Order, having been approved, is hereby promulgated for information and guidance, and necessary action.

By direction of the Naval Board,

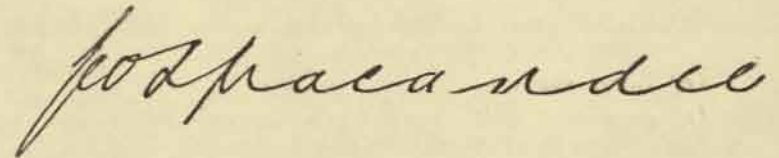

Secretary.

*The Commodore Commanding H.M.A. Squadron,
and Commanding Officers of H.M.A. Ships,
Officers in Charge of H.M.A. Naval
Establishments. and others concerned.*

TABLE OF CONTENTS.

No.	Subject.
666.	Machinery Spares—Organization for the Provision, Storing, Supply, and Accounting for Main Auxiliary Engines and Spare Gear, including Associated Electrical Gear for H.M.A. Ships and Small Craft, that is items which are not included in the Rate Book of Naval Stores or Sea Store Establishments.

666.

MACHINERY SPARES—ORGANIZATION FOR THE PROVISION, STORING, SUPPLY, AND ACCOUNTING FOR MAIN AND AUXILIARY ENGINES AND SPARE GEAR, INCLUDING ASSOCIATED ELECTRICAL GEAR FOR H.M.A. SHIPS AND SMALL CRAFT, THAT IS, ITEMS WHICH ARE NOT INCLUDED IN THE RATE BOOK OF NAVAL STORES OR SEA STORE ESTABLISHMENTS.

A new organization has been established in the Royal Australian Navy for the provision, storing, supply, and accounting of machinery and machinery spares for all H.M.A. ships and craft. It is emphasized that the supply position of all spares, particularly internal combustion engine spares, is critical, and it is essential to observe the utmost economy in their use, particular attention being paid to the following points:—

- (a) Maintenance work must be thorough.
 - (b) Spares should never be fitted unless necessary.
 - (c) All worn parts are to be salvaged when possible.
- (See paragraphs 35-38 of this Order.)

2. Machinery Spares are to be defined as under:—

- (a) All engineering items included in the lists of portable fittings and spare gear.
- (b) Spare engines.
- (c) Associated hull spares (such as rudders, rudder tubes, stern tubes, stern bearings, A brackets, &c.).
- (d) Depot spares.
- (e) Electrical spares classified as machinery spares, and including the following:—Diesel and electric generators, cranes, winches, ventilating fans and blowers, electric pumps, cool room equipment, drinking water units, laundry equipment, electric stock pots, large electric urns, electrical boiler cleaning gear, &c.

3. Replacement parts are to be defined as items required for the replenishment of the original equipment of spare gear or to satisfy requirements for certain items of the hull, machinery, or electrical parts for which (more particularly in small craft) spares were not provided.

4. (a) Naval stores, as distinct from machinery spares, are to be defined as:—

- (i) Articles included in the Rate Book of Naval Stores,
- (ii) Articles included in the Sea Store Establishments, and
- (iii) Special stores on Form D.127b, Table VIII, etc.

(b) Naval stores are to be dealt with by exactly the same procedure as in the past. Machinery spares are to be dealt with in accordance with instructions herein.

Particulars of New Organization.

5. The machinery spares are to be dealt with in a new sub-branch of the engineering and construction branch.

6. The main bulk store is in Sydney and will be the Central Machinery Spares Depot. The store is to be under the immediate control of the Engineer Manager, Garden Island, and under the local administrative control of the Naval Officer-in-Charge, Sydney. The direct management of the store will be under a Naval Engineer Officer entitled Machinery Spares Assistant to Engineer Manager.

The name and address of the Store are to be:—

Machinery Spares Store,
Holden's Buildings,
Dowling-street,
Sydney, N.S.W.

The short title of this Store is the "Central M.S. Depot, Sydney".

7. For the supply and replenishment of machinery spares, the authority of the Engineer Manager, Garden Island, has been extended to incur expenditure and to place demands and orders for this purpose. (Article 230c, clause 2 of the Naval Financial Regulations and Instructions, and Naval Board letter to the Naval Officer-in-Charge, Sydney, dated 13th May, 1943, No. 37871, refer.)

8. For the supply and replenishment of machinery spares from overseas sources, the Engineer Manager, Garden Island, will raise demands through Navy Office, or by such other procedure that may be approved in special circumstances.

Tropic Proofing and Packing.

9. When machinery spares are requisitioned for use in forward areas where damp, humid tropical conditions may exist, they are to comply with the latest current instructions covering tropic proofing and packing. These services may be carried out at contractors' works (if suitable plant exists), or at some other approved works, or may be carried out at the Central M.S. Depot. On arrival at the forward base, care is to be taken that the tropic proofing seal is not broken until the part is to be used. Thus, if the package is designed as part of the tropic proofing, it is not to be broken open until the parts in it are required for use.

Inspection.

10. For machinery spares which are to be made in Australia, the inspection for acceptance and supervision of packing are to be carried out by the Principal Naval Overseer of the State, and arrangements are to be made that he is informed of the order, plans, and specifications relevant.

Payment.

11. In accordance with paragraph 7, requisitions for supplies to this Department will be raised and orders placed by the Engineer Manager, Garden Island, or the Director of Engineering (Naval) at Navy Office. The original requisition should be forwarded to the Superintending Accountant, Garden Island; and instructions on the order should provide for claims to be rendered to that Officer.

12. (a) Where supplies have been shipped direct from the manufacturer to destinations other than the Central M.S. Depot, they are to be taken on charge on receipt of advice from the Principal Naval Overseer that the goods are satisfactory, and have been despatched. At the same time the Central M.S. Depot should take necessary action to raise a store issue note (Form M.S./D.E.(N) 20) and forward it to the receiving depot.

(b) In such cases, to enable accounts to be paid, the certificate required under Naval Account Regulations and Instructions, Article 207, should be amended to read as follows:—

“I certify that the goods referred to in this account have been despatched by the Principal Naval Overseer at _____ and taken on charge in the _____ account, and that account for these articles has not previously been certified.”

13. Machinery spares are to be accounted for on Lists of Portable Fittings and Spare Gear, referred to in A.F.O. 231/36. Replenishments are to be requisitioned on the Central M.S. Depot by procedure as under:—

14. Machinery spares for internal combustion engines for H.M.A. ships and naval craft and establishments, except those engines shown in paragraph 16, are to be requisitioned on the Central M.S. Depot, Sydney, or on other M.S. Depots, where established. Broadly, the principles laid down in A.F.O. 2415/42 will apply. Form M.S./D.E.(N) 17, *vide* Fig. 3, is to be used.

15. All other machinery spares required are to be included in a Spare Gear Defect List (Forms A.S.340 and D.275), in accordance with established practice.

16. Machinery spares required for *Main Propelling* machinery of L.S.I's *Bingera, Yandra, Kybra, Wilcannia, Whyalla*, are to be included in a defect list according to established practice.

17. Requisitions for machinery spares *must* be authorized in Sydney by the Engineer Manager or Machinery Spares Assistant, and in operational bases by the Base Engineer Officer or his assistants.

18. A record is to be kept of all appropriations of spare gear, and replenishments up to allowance are to be demanded periodically on Form M.S./D.E.(N) 17, or if required from the Dockyard, in a defect list, and paragraphs 14, 15, and 16 refer.

Forms M.S./D.E.(N) 17 (*vide* Fig. 2).

19. This form is to be used by authorities requisitioning machinery spares replenishments on the Central M.S. Depot, or on another ship. Use one copy of the form for parts for each engine. Electrical spares classified as machinery spares should not be on the same copy of the form as other spares for one particular engine.

20. *The instructions on the form are to be followed carefully*, and one copy of each requisition is to be sent to the Central M.S. Depot. If there be any doubt about the requisition arriving at its destination, a copy marked “Duplicate, by alternative route,” is to be sent by some other means, such as by another steamer, or by air. Each requisition is to be numbered. (*Vide* paragraph 31.)

21. It is of the utmost importance that requisitions are made out, complete with all details of information required, such as maker's name, model, engine type, engine number, marine conversion number (if any), as well as parts numbers and description of part. The absence of complete information may lead to delays in issuing.

22. When propellers are requisitioned, state pitch, diameter, and handing. For propeller shafts, give length from the forward face of the coupling to the large end of the cone and the taper.

23. When making requisitions by message, part number or code words are to be repeated, thus—“part number 3851, repeat 3851.” A confirming copy of the message should always follow by post marked “confirming copy.”

24. When making out requisitions for electrical parts, always provide the following information in full:—

Maker and Maker's part number.

Handing from driven end—clockwise or anti-clockwise—for rotating parts.

Voltage (D.C. or A.C. and wattage).

Maker of engine and engine type.

Maker of screening (if fitted) when requisitioning high tension leads and distributor assemblies.

25. It is essential that the issuing authority has a clear idea of the order priority of items in a requisition. For this reason Form M.S./D.E.(N) 17 is to be completed as to items (a), (b) dated, (c), and (d) by writing the word “yes” in the column intended to operate. The meanings are to be read as follows:—

Urgency (a)—Required immediately (reason such as boat unable to run, &c.).

Urgency (b) (date)—Required as soon as possible, but not later than.....

Urgency (date) (c)—Required to replenish stocks, but not required until approximately.....

Urgency (d)—Anticipated requirements for delivery in due course.

26. *Requisitions should cover requirements actually needed for replenishment, and no more.* If larger quantities are demanded than are immediately necessary, the whole organization will be thrown out of gear.

27. Authorized stocks of machinery spares for small craft, motor driven, will fall generally into three categories, namely:—

A—Machinery spares to be carried on board.

B—Machinery spares to be carried at operational bases.

C—Machinery spares to be carried at major overhaul bases.

28. Printed supplies of Form M.S./D.E.(N) 17 should be requisitioned from the Superintending Naval Store Officer, Sydney.

29. After having been edited at the Central M.S. Depot, a copy of the requisition on Form M.S./D.E.(N) 17 will be returned to the authority making the requisition, stamped as under:—

Machinery Spares Store, Sydney.

V—Will be supplied from stock.

N—Not in stock; be supplied when available.

C—On contract; be supplied when available.

P—Purchased; be supplied when available.

R—Nomenclature and stock number do not agree (cancelled).

X—Items inclusive are Naval Stores. These have been extracted to Form A.S.134b }
D.623 } Copy herewith.
D.184 }

Referred to N.S.O. / /1944.

30. Each item of the requisition will be indexed with one of the above capital letters, thus indicating action taken, or intended.

31. Each requisition sent by a ship, base, or other authority, is to be given a serial number which should be quoted in any subsequent correspondence, or in signals hastening supply.

Form M.S./D.E.(N) 18 (Vide Fig. 3).

32. (a) This form is to be used as under—

When making supply to a contractor.

When making supply to other authorities, such as Royal Navy, Army, Air Force, U.S. Navy.

(b) The unit prices are to be inserted and extended to totals in Australian currency. One copy of each requisition is to be sent to the Central M.S. Depot.

(c) These Forms will be supplied on requisitions, as for paragraph 28.

Packing Cases.

33. *Special Marking.*—All machinery spares packing cases will be marked for identification on one pair of diagonal corners with a triangular patch of brown paint (British standard) colour "Golden Brown" No. 14. The median height of the triangle measured from the corner is to be four (4) inches. At each of these corners the paint will cover top or bottom and sides. (*Vide Fig. 1, Drawing No. 500/35.*)

34. (a) All cases are to be marked on all sides with the letters "AUST. NAVY."

(b) All ordinary packing cases after use, and if in fair repair and if freight charges are justified and not excessive, are to be returned to the Central M.S. Depot, Sydney, N.S.W., addressed in accordance with paragraph 6 herein.

(c) All packing cases which have been provided for a specific purpose, such as "*Hall Scot Engine Transportation Cases*" must be returned. Return notes should be raised to cover these transactions.

Salvage.

35. All parts on replacement are to be examined and, if considered serviceable, subject to repair, are to be returned to the Central M.S. Depot, Sydney, marked and consigned to Machinery Spares Store, Holden's Buildings, Dowling-street, Sydney, N.S.W. All parts returned for salvage are to be returned on return note.

36. In view of the general shortage of spare gear, it is essential that the fullest possible care should be taken to ensure that no components or material which can be reclaimed or used again, should be scrapped.

37. The principal classes of gear which can normally be salvaged are given in Appendix "A" at the end of this Order.

38. (a) When returning spare gear to the Central M.S. Depot from a ship or forward base, Form M.S./D.E.(N) 32 is to be used, and disposed of in accordance with the instructions on the Form. When spare gear is being returned to the Central M.S. Depot, from some other origin, Form M.S./D.E.(N) 31 is to be used for the purpose.

(b) All items returned to Central M.S. Depot, Sydney, for salvage must be properly packed and put in a state of preservation to ensure that they do not deteriorate or receive damage in transit. A label is to be attached to each item stating base, ship, or craft from which removed, make and model of engine or electrical machine, description of item, and maker's part number, where known.

Shipping and Transport.

39. These services are to be arranged for, as far as possible, through channels already established and operating, and should follow procedure already laid down.

Completion and Return of Store Invoice Receipt (Form M.S./D.E. (N) 20).

40. Whenever machinery spares are received the store invoice receipt marked No. 1 ORIGINAL which was posted, notifying the despatch of the package or packages, is to be completed and returned as noted on the form. This is essential so that inquiries may be made promptly when goods despatched do not come to hand. The other copies of this form are to be disposed of as indicated on the relevant copies of them.

Effective Date for Change-over.

41. A date will be communicated after which machinery spare gear is to be dealt with according to paragraphs 13, 14, 15, 16, and 17 of this Order.

42. As from the date on which this Order operates, all matters relative to machinery spares should be dealt with by ships' engineer officers and base engineer officers direct with the new sub-branch, and not through naval store officers, or ship's or base naval storekeeping officers.

APPENDIX A.

All instruments.
 All types of electrical equipment.
 Any copper, brass or bronze items.
 Ball and Roller bearings.
 Bearing shells.
 Bosch and Excello fuel pumps.
 Cams.
 Camshafts.
 Cam Rollers and Pins.
 Chains.
 Connecting Rods.
 Connecting Rod and Bearing Bolts.
 Cooler and Heat Exchanger Elements and Tubes.
 Couplings.
 Crankshafts.
 Cylinder Heads.
 Electrical meters (attached to engines).
 Filter and strainer elements.
 Fuel and Lubricating Oil Pumps and parts.
 Gears, gear hubs, and sprockets.
 Governors and parts.
 Hydraulic governors.
 Injectors and parts.
 Pistons.
 Piston Pins.
 Piston Pin Bushings.
 Rocker Shafts, fuel pump shafts, and control shafts.
 Springs.
 Studs.
 Tachometers.
 Tachometer generators.
 Thermocouples.
 Valves.
 Water pumps and parts.

NAVY OFFICE, MELBOURNE	
DRG. NO. 500130	
DATE - 2 / 8 / 44	
COPY NO. M5D	
DRAWN BY	J. P. P. 22
CHECKED BY	J. P. P. 22
APPROVED BY	M. L. R. 22
APPROVED	<i>M. L. Rully</i>

MACHINERY SPARES - STORE
MARKING OF CASES
SCALE - 1 1/2 INCHES = 1 FOOT

NOTES

1. ALL PACKAGES CONTAINING MACHINERY SPARES, ARE TO BE MARKED ON ONE FACE OF DIAGONAL CORNER WITH TRIANGLE OF A MEDIAN HEIGHT OF 4 INCHES, THE CORNER BEING 60°/120° STANDARD ANGLE - (CONFER ABOVE)

2. ALL PACKAGES FOR DESPATCH TO FORWARD OPERATIONS, SHALL BE SO MARKED IN ADDITION TO THE USUAL MARKING, THE WORD "AUST. NAVY" LEGIBLY STENCILED IN APPROPRIATE FONT ON ALL SIDES OF THE CASE. THE WORDS "AUST. NAVY" IS TO BE A MINIMUM OF 3/16 INCHES FOR CASE CORNER, AND IS TO BE REDUCED AS NECESSARY FOR MEDIUM AND SMALL CASES.

3. SMALL PACKAGES MAY BE SUPPLIED WITH METAL TALLIES, THESE POINTS BY TWO INCHES IN DIAGONAL, WITH THE LETTERING "AUST. NAVY" STENCILED THEREON.

4. S.A.S. 107 OF 1944 APPLIES

FIG. 1

DETAIL OF CORNER

MS/DE(N) 17

DEPARTMENT OF THE NAVY
MACHINERY SPARES SUB-BRANCH

SHIP PROVIDE
SERIAL REF. NO. _____

REQUISITION
(SHIPS AND ESTABLISHMENTS)

DATE _____

FROM _____

TO: MACHINERY SPARES STORE
HOLDEN'S BUILDING
DOWLING STREET
SYDNEY N.S.W.

ENGINE: MAKER _____ TYPE _____

VESSEL: NAME _____ REGISTERED NO. _____

SHIP OR SERVICE _____

ITEM NO.	DESCRIPTION *	PART NO.	DRAWING NO.	NO. REQUIRED AND URGENCY					
				(a)	(b)	DATE	(c)	(d)	

* ELECTRICAL ITEMS MUST BE KEPT SEPARATE FROM ENGINE ITEMS

† THE DEGREE OF URGENCY INDICATED BY (a), (b), (c) OR (d) IS AS FOLLOWS:-

(a) REQUIRED IMMEDIATELY

(b) REQUIRED AS SOON AS POSSIBLE, BUT NOT LATER THAN _____

(c) REQUIRED TO REPLENISH STOCKS, BUT NOT REQUIRED UNTIL APPROXIMATELY _____

(d) ANTICIPATED REQUIREMENTS FOR DELIVERY IN DUE COURSE

CERTIFIED THAT THE ABOVE QUANTITIES ARE NOT IN EXCESS OF THOSE AUTHORISED

NAME _____

RANK _____ DATE _____

FIG 2

MS/DE(N) 18

DEPARTMENT OF THE NAVY
MACHINERY SPARES SUB-BRANCH

SHIP PROVIDE
SERIAL REF. NO. _____

REQUISITION
(EXTERNAL SERVICES)

DATE _____

FROM _____

TO: MACHINERY SPARES STORE
HOLDEN'S BUILDING
DOWLING STREET
SYDNEY N.S.W.

ENGINE: MAKER _____ TYPE _____

VESSEL: NAME _____ REGISTERED NO. _____

SHIP OR SERVICE _____

ITEM NO.	DESCRIPTION *	PART NO.	DRAWING NO.	NO. REQ.	UNIT	UNIT PRICE	EXTENSION

* ELECTRICAL ITEMS MUST BE KEPT SEPARATE FROM ENGINE ITEMS

TOTAL £ _____

CERTIFIED THAT THE ABOVE QUANTITIES ARE NOT IN EXCESS OF THOSE AUTHORISED

NAME _____

POSITION/RANK _____ DATE _____

FIG 3

RESTRICTED.(FOR OFFICIAL USE ONLY.)

Commonwealth Navy Orders.

Navy Office, Melbourne,
19th December, 1944.

The following Orders, having been approved, are hereby promulgated for information and guidance, and necessary action.

By direction of the Naval Board,

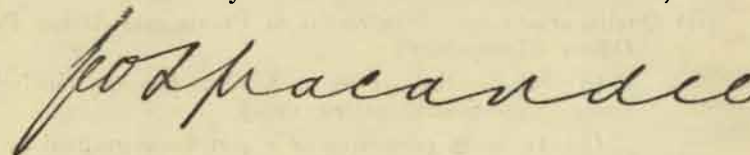

Secretary.

*The Commodore Commanding H.M.A. Squadron,
and Commanding Officers of H.M.A. Ships,
Officers in Charge of H.M.A. Naval
Establishments, and others concerned.*

TABLE OF CONTENTS.

No.	Subject.
667.	Advancement of Ratings Serving in Services Reconnaissance Department Far Eastern Liaison Office and Allied Intelligence Bureau.
668.	Educational Test I—September, 1944.
669.	Investigations Concerning the Welfare of Relatives of Naval Personnel.
670.	Commonwealth Reconstruction Training Scheme.
671.	Pattern 100 Inglefield Clips—Defect in Manufacture.
672.	Deafness Due to Gunfire—Recording in Medical Officers' Journals.
673.	Anti-Cholera Inoculation.
674.	H.M.A. Ships—Signatures of Issuing Officers on Travelling Warrants.
675.	Cash Advances to H.M.A. Ships from U.S. Ships or Bases.
676.	Rockets Illuminating 3½ lb.—Prematures.

667.

ADVANCEMENT OF RATINGS SERVING IN SERVICES
RECONNAISSANCE DEPARTMENT, FAR EASTERN LIAISON
OFFICE AND ALLIED INTELLIGENCE BUREAU.

The following conditions have been approved for the advancement of seaman ratings serving in the Services Reconnaissance Department, Far Eastern Liaison Office and Allied Intelligence Bureau, who have not qualified professionally under general service conditions, but are considered suitable in all other respects for advancement to the next higher rating:—

(i) Qualifications for advancement to Provisional Acting Leading Seaman (Temporary)—

(a) Six months' service as Able Seaman.

(b) To be in possession of a certificate granted by the Senior Naval Officer stating that he is considered suitable in all respects for advancement to the higher rating.

(c) Six months "V.G." time immediately prior to advancement.

(ii) Qualifications for advancement to Provisional Acting Petty Officer (Temporary)—

(a) Six months' service as Leading Seaman (including provisional acting time).

(b) To be in possession of a certificate granted by the Senior Naval Officer stating that he is considered suitable in all respects for advancement to the higher rating.

(c) Twelve months "V.G." time immediately prior to advancement.

2. Recommendations for advancement are to be made on Form A.S. 507 which is to be approved by the Senior Naval Officer and are to be forwarded to the Naval Officer-in-Charge, Flinders Naval Depot, on the last day of each month.

3. All advancements made under this Order will be to the provisional acting rating (temporary) only, and will be authorized by the Naval Officer-in-Charge, Flinders Naval Depot, in vacancies in the schemes of complement of these special services.

4. A rating holding the provisional acting higher rating will revert to the confirmed rating last held on reversion to general service. Similar conditions for temporary advancement to the higher rating will apply to other branches of the Royal Australian Navy allowed by complement for these special services.

5. This Order supersedes instructions previously issued by letter to some authorities, but does not invalidate advancements already made.

(568/202/1020.)

668.

EDUCATIONAL TEST I—SEPTEMBER, 1944.

The following ratings passed the Educational Test I held on the 19th September, 1944:—

Name.	Rating.	Official Number.
<i>H.M.A.S. Adelaide.</i>		
O'Keeffe, Dermott J.	Stoker	F/4742
Shaddick, Jack S.	Stoker	F/4312
Tomkins, Cecil W. N.	Jnr., 4th Class	S/8619
<i>H.M.A.S. Broome</i>		
Burgess, Gordon M.	Stoker	S/6343
Smith, Keith G.	Stoker	H/1756
Walsh, Vivian J.	Stoker	B/3262
<i>H.M.A.S. Cerberus</i>		
Babidge, Lewis A. G.	Stoker, 2nd Class	W/2967
Bowman, Leslie J.	Stoker	B/3528
Corbett, Eric	Stoker	W/2519
Fabian, Colin	Stoker, 3rd Class	B/5090
Hobbs, Samuel John	Stoker, 2nd class	S/9145
Hopkins, Donald J.	Stoker, 2nd Class	P.A/3571
Johnson, Angus G.	Stoker	B/3965
Johnston, Harry S.	Stoker	B/3726
Lascelles, Geoffrey G.	Stoker, 3rd Class	B/5087
Lemke, Gordon L.	Stoker	F/4527
Lingard, Raymond H.	Stoker, 2nd Class	B/5088
Low, Alexander F.	Stoker, 3rd Class	S/9350
Millar, Edmund J.	Acting Petty Officer (Ty.)	21720
Murphy, Donald S.	Stoker, 3rd Class	H/2743
McCarthy, James V.	Stoker, 2nd Class	W/3012
McDonald, Donald J.	Stoker	W/3005
McNamara, Gordon P. M.	Stoker, 2nd Class	F/5330
Parker, Paul	Stoker, 2nd Class	S/9151
Paulson, Keith	Stoker, 3rd Class	S/9449
Pound, John R.	Stoker, 2nd Class	W/3028
Scarlett, Thomas T.	Stoker	W/2123
Sewell, Allan E.	Stoker, 2nd Class	W/2975
Smeaton, George F.	Stoker	W/2366
Switzer, Alan L.	Stoker, 2nd Class	S/9488
Teakle, Angus E.	Stoker	P.A/2943
Ward, Mervyn K.	Stoker	P.A/3136
Wheate, George R.	Stoker, 3rd Class	S/9379
<i>H.M.A.S. Geraldton</i>		
Bowles, Gilbert	Stoker	26195
Newman, Edward J.	Able Seaman	S/6905
<i>H.M.A.S. Ladava</i>		
Corvaia, Guiseppe	Acting Able Seaman	B/4471
<i>H.M.A.S. Leeuwin ("Mary Cam")</i>		
Williams, Alan H.	Able Seaman	B/4183

EDUCATIONAL TEST I—SEPTEMBER, 1944.—*continued.*

Name.	Rating.	Official Number.
H.M.A.S. <i>Melville</i> (Including Boom Defence and Tenders)		
Butterworth, Henry W.	Leading Seaman	B/932
Dedear, Vernon	Able Seaman	P.A/V86
Galbraith, Harold E.	Stoker	24093
Gattrell, Arthur E. H.	Stoker	W/2928
Green, Kenneth J.	Stoker	S/8270
Hill, Harold R.	Ordinary Seaman	H/2673
Jeffreys, Harold W.	Stoker	W/2050
Kies, Robert M.	Able Seaman	P.A/4139
Wilson, Beresford	Stoker Petty Officer	23448
H.M.A.S. <i>Penguin</i>		
Dyer, Robert D.	Signaller	S/6748
Murray, Brian S.	Stoker	26717
H.M.A.S. <i>Shropshire</i>		
Harry, William J.	Stoker Petty Officer	24356
H.M.A.S. <i>Westralia</i>		
Jones, Malcolm S.	Telegraphist	P.M/2341
Lake, Victor H.	Telegraphist	SV/55
The following qualified educationally for Acting Leading Stoker:—		
H.M.A.S. <i>Adelaide</i>		
Waski, Raymond A.	Leading Stoker (Ty.)	24752
H.M.A.S. <i>Cerberus</i>		
Borthistle, Robert A.	Stoker, 2nd Class	S/9522
Bradley, Brian R.	Stoker, 3rd Class	B/5085
Brush, James H.	Stoker, 2nd Class	W/2961
Firmin, Desmond S.	Stoker, 3rd Class	F/5335
Paxton, John B.	Stoker, 2nd Class	S/9360
Perry, David W.	Stoker, 3rd Class	P.A/4712
Rich, Henry J.	Stoker	F/4397
Robinson, Alan H.	Stoker	W/2524
Underwood, John T.	Stoker, 2nd Class	W/3029
H.M.A.S. <i>Melville</i> (Including Boom Defence and Tenders)		
Evans, Leo W.	Stoker	26114

(465/205/665.)

(This Order will be reprinted for posting on Notice Boards.)

669.

INVESTIGATIONS CONCERNING THE WELFARE OF RELATIVES OF NAVAL PERSONNEL.

When application is made for investigations concerning the welfare of relatives of Naval personnel, care should be taken to include the full and correct addresses in all communications.

2. The address of the doctor in attendance, if known, should also be communicated when necessary.

(443/201/1411.)

670.

COMMONWEALTH RECONSTRUCTION TRAINING SCHEME.

Under the Commonwealth Reconstruction Training Scheme, many additional trade instructors will be needed in Technical Schools and Colleges and similar training organizations, particularly in the Building Trades.

2. Though the services of these instructors will generally not be required until the cessation of hostilities, or just prior thereto, it is desired to give members of the Forces who wish to be considered for such appointments an early opportunity of lodging applications for selection at a later date.

3. Instructors will be appointed as temporary trade instructors by the appropriate State Public Service authority. Conditions of training and employment may be obtained, together with application forms, from the Deputy Director of Industrial Training in the State concerned.

4. Applicants are required to be fully qualified tradesmen, preferably with some experience as instructors. Selected applicants without satisfactory teaching experience may be required to undergo a short intensive course of training, during which the appropriate rates for instructors will be paid.

5. The addresses of Deputy Directors of Industrial Training are as follows:—

A.C.T.—Canberra Technical College.

New South Wales.—Sydney Technical College, Ultimo, Sydney.

Victoria.—V.C.A. Building, Flinders-street, Melbourne.

Queensland.—Department of Public Instruction, Brisbane.

South Australia.—Education Department, Adelaide.

Western Australia.—Perth Technical College, Perth.

Tasmania.—Education Department, Hobart.

6. This Order is promulgated at the request of the Industrial Training Division of the Department of Labour and National Service. It is to be clearly understood that successful applicants will not necessarily be released, since release must at all times be determined by Service requirements.

(840/201/15.)

(This Order will be reprinted for posting on Notice Boards.)

671.

PATTERN 100 INGLEFIELD CLIPS—DEFECT IN MANUFACTURE.

Reports indicate that numerous failures of pattern 100 Inglefield clips have occurred.

2. Due to the unsatisfactory rivetting of the shank of the swivel, the retaining washers have been forced off, causing the parting of the top and bottom portions of the clip.

3. This defect has been remedied in clips of more recent manufacture, but ships and establishments should inspect all Inglefield clips and any found defective should be adjusted, if possible, or replaced.

(612/218/250.)

672.

DEAFNESS DUE TO GUNFIRE—RECORDING IN MEDICAL OFFICERS' JOURNALS.

The attention of all Commanding Officers and Medical Officers is called to A.F.O. 5150/44, the provisions of which are to be strictly carried out in the R.A.N. In ships and establishments where no medical officer is borne, but a sick berth rating only, the Commanding Officer is to take the requisite steps to ensure that the necessary notation is made by the sick berth rating in the Medical Journal.

2. In all other cases the particulars are to be recorded in Form A.M. 209z, Daily Journal of the Sick.

(527/210/4200.)

673.

ANTI-CHOLERA INOCULATION.

The attention of all concerned is drawn to the regulation in force at Cairo regarding inoculation against cholera. This regulation requires that all passengers arriving at Cairo west-bound either terminal or transit must be in possession of a certificate of anti-cholera inoculation dated not less than six days or more than six months from date of arrival at Cairo.

2. Passengers arriving at Perth for journeys to and through Cairo must have the necessary inoculation certificate in their possession.

3. As a similar certificate may be demanded by the Canadian or U.S. Authorities, all Naval personnel travelling by air to the United Kingdom via Canada or the United States should take steps before departure to comply with the above requirement.

(527/202/430.)

674.

H.M.A. SHIPS—SIGNATURES OF ISSUING OFFICERS ON TRAVELLING WARRANTS.

Attention is directed to the requirements of Naval Account Regulations and Instructions, Article 317, regarding officers authorized to issue travelling warrants, which reads as follows:—

“(1) In H.M.A. Ships the Commanding Officer will sign travelling and freight warrants.

At an establishment or office, the person signing should not be lower than a Lieutenant or the Senior Clerical Officer except in special circumstances of which the Director of Navy Accounts should be advised at the time the warrant is issued.

The officer who signs a warrant will be responsible that the person to whom the warrant is issued is travelling on duty or is entitled to the warrant under the specific instructions of the Naval Board.

(2) Officers authorized to issue warrants should note that they are in the nature of cheques and should, therefore, be prepared and issued with every regard to the prevention of unauthorized use, and to ensuring that accounts can be readily checked and passed for payment.”

2. Care is to be taken to ensure that these instructions are closely observed.

(401/221/1011.)

675.

CASH ADVANCES TO H.M.A. SHIPS FROM U.S. SHIPS OR BASES.

Where cash advances are made to H.M.A. Ships by United States Ships, the financial adjustment between the Commonwealth and the United States Governments is effected in Washington.

2. For this purpose, Commanding Officers of H.M.A. Ships concerned should inform the Director of Navy Accounts, Melbourne, by signal, of any such advance on the date it is received. In all instances where ships do not carry their own accounts, the signal should be repeated to the parent ship or base. As adjustment will be arranged by Navy Office on receipt of this advice, no other authorities should be informed.

3. The advice should state the amount received in American currency and also the Australian currency equivalent converted at the rate of 3.228 dollars to £1 Australian.

4. Navy Order 303 of 1944 is cancelled.

(405/201/778.)

676.

ROCKETS ILLUMINATING 3 $\frac{3}{4}$ LB.—PREMATURES.

The following amendment is to be made to Navy Order 40 of 1944, sub-paragraph (i):—

Delete the word “clamp” and substitute the word “lash.”

(471/208/1245.)

RESTRICTED.(FOR OFFICIAL USE ONLY.)

Commonwealth Navy Orders.

Navy Office, Melbourne,
26th December, 1944.

The following Orders, having been approved, are hereby promulgated for information and guidance and necessary action.

By direction of the Naval Board,

J. O. Macarandee
Secretary.

*The Commodore Commanding H.M.A. Squadron,
and Commanding Officers of H.M.A. Ships,
Officers in Charge of H.M.A. Naval
Establishments, and others concerned.*

TABLE OF CONTENTS.

No.	Subject.
677.	Appointments.
678.	Port Directors.
679.	Honours and Awards to R.A.N. Personnel.
680.	Period of Shore Service at Darwin and Thursday Island.
681.	Confirmation and Provisional Promotions of R.A.N.R. and R.A.N.V.R. Officers in Time of War.
682.	Internal Combustion Engines—Preparation for Stowage and/or Subsequent Transit of Used Engines after Removal from Boat.
683.	Ordnance B.L.—Care of Obturator Seatings and Pads.
684.	Depth Charge Pistol Mk. VII*, Reg. No. 4614.
685.	Machine Tools—Co-ordinated Use in Australia Between the Services.
686.	Bomb and Mine Disposal Work—First-aid Precautions.
687.	Naval Stores in Small Vessels—Responsibility as to Custody.
688.	Damage to Signal Flags by Rigging Insulators.
689.	Instructions for Drivers of Naval Motor Services—Form N.M.T. 7.
690.	Souvenirs of Enemy Origin and Dangers Attendant Thereto.
691.	Magazine Logs—Rendering.
692.	Completion of Medical and Rehabilitation Forms for Discharged Personnel.

677.

APPOINTMENTS.

Commodore of the First Class, H. B. Farncomb, D.S.O., M.V.O., assumed duty as Commodore Commanding H.M.A. Squadron and Commander Task Group 74.1 on 9th December, 1944, *vice* Commodore Collins, C.B.

(1804/2/87.)

678.

PORT DIRECTORS.

With reference to Navy Order 425 of 1944, a R.A.N. Port Director has been appointed at Jacquinot Bay.

(1804/2/88.)

679.

HONOURS AND AWARDS TO R.A.N. PERSONNEL.

With reference to Navy Order 515 of 1944, the following additional Honours and Awards have been made to personnel of the Royal Australian Navy:—

For great gallantry and undaunted devotion to duty.

THE GEORGE CROSS.

Lieutenant Leon Verdi Goldsworthy, G.M., R.A.N.V.R.

2. *For gallantry, skill, determination and undaunted devotion to duty, during the landing of Allied Forces on the coast of Normandy.*

SECOND BAR TO DISTINGUISHED SERVICE CROSS.

Lieutenant Kenneth Robert Hudspeth, D.S.C. and Bar, R.A.N.V.R.

3. *For outstanding courage, skill and determination in pressing home a successful attack on the Japanese Naval Base at Sabang.*

BAR TO DISTINGUISHED SERVICE CROSS.

Lieutenant Otto Humphrey Becher, D.S.C., R.A.N.

THE DISTINGUISHED SERVICE CROSS.

Lieutenant Geoffrey Vernon Gladstone, R.A.N.

THE DISTINGUISHED SERVICE MEDAL.

Chief Petty Officer James Henry Hutchings, O.N. 13779.

MENTION IN DESPATCHES.

Lieutenant Walter James Reid, R.A.N.V.R.

Chief Stoker Reginald Norman Leatch, O.N. 19267.

Acting Ordnance Artificer, 4th Class, Ernest David Hartley, O.N. B/3466.

Petty Officer Cook Donald Arthur Ferguson, O.N. S/3630.

Acting Leading Seaman Edward Lloyd Maxwell, O.N. H/1336.

4. *For outstanding service in the face of the enemy.*

THE DISTINGUISHED SERVICE CROSS.

Lieutenant William Miles Marley, R.A.N.V.R.

5. *For gallantry in the face of the enemy.*

THE DISTINGUISHED SERVICE CROSS.

Acting Lieutenant-Commander Ronald McKauge, R.A.N.V.R.

Lieutenant Charles Throgmorton Ball, R.A.N.V.R.

6. *Bravery, skill and devotion to duty in H.M.S. Eskimo in anti U-Boat operations.*

THE DISTINGUISHED SERVICE CROSS.

Lieutenant Hugh David McDonald, R.A.N.V.R.

7. *For courage, resolution and skill in H.M.S. Loch Killian in anti U-Boat operations.*

THE DISTINGUISHED SERVICE CROSS.

Lieutenant-Commander Stanley Darling, R.A.N.V.R.

8. *For outstanding service in various operations in the Mediterranean.*

THE DISTINGUISHED SERVICE CROSS.

Lieutenant Edwin Joseph Gregg, R.A.N.V.R.

9. *For outstanding courage, resolution and skill whilst serving in light coastal craft in many successful engagements with the enemy.*

THE DISTINGUISHED SERVICE CROSS.

Lieutenant Thomas John Scott, R.A.N.V.R.

10. *For distinguished service in light coastal craft and in H.M.S. Onslaught.*

THE DISTINGUISHED SERVICE CROSS.

Lieutenant John Ferguson, R.A.N.V.R.

MENTION IN DESPATCHES.

Lieutenant John Francis Britton, R.A.N.V.R.

11. *For gallantry, skill and undaunted devotion to duty during the landing of Allied Forces on the coast of Normandy.*

THE DISTINGUISHED SERVICE CROSS.

Lieutenant George Archibald Ramsay, R.A.N.V.R.

12. *For courage and endurance in the care of survivors from a torpedoed merchant ship.*

BRITISH EMPIRE MEDAL (MILITARY).

Acting Petty Officer (D.E.M.S.) Alfred Eric Seivers, O.N. PM/1577.

MENTION IN DESPACHES.

13. (a) *For gallantry in the face of the enemy.*
Lieutenant Richard John Slattery, R.A.N.V.R.
- (b) *For zeal, patience and cheerfulness in dangerous waters.*
Lieutenant Vere Gordon Thorn, R.A.N.V.R.
- (c) *For courage, resolution and skill in H.M.S. Tenacious in anti U-Boat operations.*
Lieutenant Kenneth Baillieu Myer, D.S.C., R.A.N.V.R.
- (d) *For courage and determination in D.E.M.S. Mauritius in a series of successful attacks on enemy escorted convoys off the coast of France.*
Mr. John Henry Dawson, Acting Gunner, R.A.N.
- (e) *For gallantry, skill, determination and undaunted devotion to duty during the landing of Allied Forces on the coast of Normandy.*
Acting Lieutenant-Commander Stewart Linton Browne, R.A.N.V.R.
Acting Lieutenant-Commander Robert Kenley Hart, R.A.N.V.R.
Lieutenant Henry Somerville Paterson, R.A.N.V.R.
Lieutenant Alfred Ernest Weston, R.A.N.V.R.
- (f) *For courage, resolution and skill while serving in H.M.S. Wensleydale.*
Lieutenant Francis Arthur Robert Humphrey, R.A.N.V.R.
- (g) *For courage and skill in H.M.S. Cooke in anti U-Boat operations.*
Sub-Lieutenant Malcolm Gilbert Cowie, R.A.N.V.R.

FOREIGN AWARDS AND DECORATIONS.

14. *For distinguishing himself by extraordinary heroism against an armed enemy during his assignment as coast watcher on an island in the Pacific, from the 12th February, 1943, to 18th September, 1943. Although constantly in danger of discovery and capture by enemy forces and handicapped by ill health and failure of equipment, Lieutenant Firth obtained information regarding enemy activities which was of invaluable assistance in the planning of offensive operations and in the preparation of defences against enemy activities.*

LEGION OF MERIT.

Degree of Officer.

(Conferred by the President of the U.S.A.)

Lieutenant Robert Firth, R.A.N.V.R.

(448/201/1507.)

(This Order will be reprinted for posting on Notice Boards.)

680.

PERIOD OF SHORE SERVICE AT DARWIN AND THURSDAY ISLAND.

It has been decided to reduce the period of shore service at Darwin and Thursday Island to twelve months, as far as reliefs are available.

2. Personnel so relieved will be granted leave on the expiration of their period of service.

3. A monthly return should be rendered by the Commanding Officers concerned to the Naval Officer-in-Charge, Flinders Naval Depot, giving the names of ratings who will complete twelve months' service on the Station within the ensuing two months. On receipt of this return, the Naval Officer-in-Charge, Flinders Naval Depot, will cause the Commanding Officers to be furnished with information regarding those ratings who will be relieved when due, or the anticipated dates of relief after completion of the twelve months' period.

4. Interim leave in accordance with Navy Order 410 of 1942 is in future to be granted only to personnel who cannot be relieved after twelve months' service or within a reasonable period thereafter.

(520/201/1190.)

681.

CONFIRMATION AND PROVISIONAL PROMOTION OF R.A.N.R. AND R.A.N.V.R. OFFICERS IN TIME OF WAR.

With reference to Navy Order 538 of 1943, paragraphs 1 and 3, for "A.F.O. 6000/42" read "A.F.O. 4995/44".

(568/201/807.)

682.

INTERNAL COMBUSTION ENGINES — PREPARATION FOR STOWAGE AND/OR SUBSEQUENT TRANSIT OF USED ENGINES AFTER REMOVAL FROM BOAT.

It has been reported that certain internal combustion engines returned to major repair depot for overhaul from forward bases have sometimes been received in a generally dirty and rusty condition.

2. Attention is directed to the following procedure which is to be complied with immediately prior to and after an internal combustion engine is removed from the vessel for stowage awaiting overhaul and/or any other purpose to prevent deterioration due to climatic conditions.

3. Procedure prior to removal from boat—

(a) Normal preliminary procedure for application of Internal Corrosion Inhibitor—

(i) Drain oil from sump.

(ii) Replace oil with Corrosion Inhibitor, Type E, Grade 2 (SAE 30 Viscosity), to normal working level.

(iii) Start up engine and run at between one-third to one-half normal maximum revolutions for not longer than five minutes. This will circulate the Corrosion Inhibitor, Type E, throughout the whole system.

(b) Special preliminary procedure for application of Internal Corrosion Inhibitor to Hall Scott geared engines—

(i) Drain oil from sump, and in addition remove as much oil as possible from the gear box sump.

(ii) Replace oil with Corrosion Inhibitor, Type E, Grade 2 (SAE 30 Viscosity).

(iii) Prior to starting up the engine for the five minutes' run under conditions stated in paragraph 3 (a) (iii) above, disengage "Sailing Clutch" and engage "Ahead Clutch" as the gear box oil pump does not operate unless clutch is in gear.

4. Procedure after removal from boat—

(i) Drain out Corrosion Inhibitor, Type E, from engine sump and gear box (if fitted) and return to store for treating subsequent engines.

(ii) Remove spark plugs and inject approximately 2 ounces Corrosion Inhibitor, Type E, into each cylinder with spray gun or syringe. During this operation the engine is to be turned over by hand to ensure the application of a protective coat of Corrosion Inhibitor to the cylinder walls.

(iii) Immerse spark plugs in the Corrosion Inhibitor, Type E, and immediately replace in the cylinder.

(iv) Remove rocker arm covers.

(v) Spray Corrosion Inhibitor, Type E, over Cam shaft rocker arms, valve stems, etc., to ensure adequate protection.

(vi) Replace rocker arm covers.

5. Procedure for application of external Corrosion Inhibitor—

(i) The engine is to be thoroughly cleaned down externally with a petroleum solvent which should be a neutral water white petroleum distillate having a minimum flash point of 78°F. (white spirit, mineral turpentine, or similar solvents) applied by scrubbing with a brush or by wiping with saturated cloths. Petroleum solvents should be used at room temperature. They should be handled in safety tanks and fire extinguishers are to be provided, as such solvents are highly inflammable. Cleaning down is most important, and every care is to be taken to prevent contamination after cleaning down and before the application of the Corrosion Inhibitors.

(ii) Care is to be taken to protect all personnel engaged on cleaning down and applying Corrosion Inhibitors to engines from dermatitis or similar skin affliction. If available, a 50-50 mixture of lanoline and mutton fat used as an ointment before starting work will be found effective. Clean gloves, if available, may also be worn.

(iii) All external metal parts are to be coated with Corrosion Inhibitor, Type B (grease type). The Corrosion Inhibitor, Type B, is to be applied immediately after the cleaning and drying. It is to be applied hot (160° to 180°F.) to coat all surfaces uniformly and continuously by brushing.

6. Crating and Storing after treatment—

(i) When the application of the Corrosion Inhibitor has been completed, the internal combustion engine is to be crated in the appropriate crate, if available.

(ii) The crated internal combustion engine is to be stored in a weather-proof store house. The crate is to be stored in such a manner as to enable a circulating air current to flow wholly around the major portion of the crate in order to prevent the attack by fungoid growth or termites.

(524/202/2014.)

683.

ORDNANCE B.L.—CARE OF OBTURATOR SEATINGS AND PADS,

Damage to obturator seatings of B.L. guns has recently been reported.

2. Every care must be taken to prevent damage to obturator seatings both in loading and while cleaning the bore.

3. Pads have been found considerably over gauge dimensions owing to absorption of oil. Bores of guns must be sponged out frequently, and lightly oiled, to prevent rusting, but an abnormal quantity of oil is likely to run back into the chamber and be absorbed by the pad, especially if the gun is left at elevation.

4. Moreover, an abnormally oiled bore produces an increased chamber pressure which may cause damage to the gun by expanding the bore, particularly at the muzzle end.

4. Obturator seatings must be frequently inspected and pads gauged, especially after firing, to ensure that obturation is efficient.

6. Attention is drawn to B.R.292 and Addendum No. 1, paragraphs 51-85.

(490/204/522.)

684.

DEPTH CHARGE PISTOL MK. VII*, REG. No. 4614.

It has recently been reported that history sheet for depth charge pistol Mk. VII*, Reg. No. 4614, was found in the box containing depth charge pistol Reg. No. 4573.

2. The present whereabouts of depth charge pistol Mk. VII* Reg. No. 4614 is not known, and a report is to be furnished to Navy Office by the holder of this pistol, stating what history sheet is held.

(471/205/2309.)

685.

**MACHINE TOOLS—CO-ORDINATED USE IN AUSTRALIA
BETWEEN THE SERVICES.**

The principal workshops operated by the Services as detailed in Appendices "A" and "B" to this Order are also available for reciprocal work between the Services, and are to be included with those promulgated in Navy Order 611 of 1944.

APPENDIX "A".

**PRINCIPAL WORKSHOPS OPERATED BY THE SERVICES IN NORTHERN
QUEENSLAND WITH BRIEF DETAILS OF MACHINE TOOLS INSTALLED.**

Tolga.—No. 3 Australian Advanced Workshop—Australian Electrical and Mechanical Engineers.

- Machine, boring cylinder, electric, No. 2.
- Machine, brake drum truing.
- Machine, drilling, radial, 36-in.
- Machine, grinding, crankshaft, 72-in., "Norton".
- Machine, boring and honing cylinder, "Barnes" 306C.
- Machine, boring line, "Tobin-Arp".
- Machine, milling, Universal No. 2.
- Machine, remetalling and boring bearings, aligning piston gudgeon pins.
- Machine, shaping, 14-in.
- Plants, welding, electric transformer, type 7KVA.

Townsville.—Townsville Area Workshop—Australian Electrical and Mechanical Engineers.

- Lathe, 8-in. short bed.
- Lathe, 7½-in. long bed.
- Machine, shaping, 14-in.
- Machine, woodworking, Universal.
- Plant, welding, electric transformer, type 7KVA.

Townsville.—Naval Base.

- Lathe, precision cabinet, 3½-in. centre, "CVA".
- Machine, boring, OPG No. 2, "Kearns".
- Machine, shaping, 18-in., Ormerod type.
- Machine, milling, plain, "Kearney & Trecker" No. 3H (with "Austolite" semi-universal dividing head).
- Machine, drilling, radial, 3-in., "Town".
- Machine, woodworking—Lathe, 6-in.
- Machine, woodworking—Planer and thicknesser, 24 in. x 8 in.
- Machine, woodworking—Saw bench, 32-in.
- Machine, woodworking—Bandsaw, 32-in.
- Lathe, engine, "Simmonds" (18-in. swing over ways—10-ft. bed).
- Lathe, 4½-in. centre, "South Bend", Type 4.
- Press, hydraulic, 60-ton, with test centre attachment.

APPENDIX "B".

**PRINCIPAL WORKSHOPS OPERATED BY THE SERVICES IN NORTHERN
TERRITORY AND CENTRAL AUSTRALIA WITH BRIEF DETAILS OF
MACHINE TOOLS INSTALLED.**

*88½ Mile.—Northern Territory Lines of Communication Area Workshop
—Australian Electrical and Mechanical Engineers.*

- Hoist, hydraulic, 6,000-lb.
- Lathe, 4½-in.
- Lathe, 6-in. (three).
- Lathe, 8-in.
- Lathe, 9-in.
- Lathe, 15-in.
- Lathe, brake drum truing.
- Machine, boring, cylinder.
- Machine, drilling, radial, 36-in.
- Machine, drilling, radial, 42-in.
- Machine, grinding, electric piston.
- Machine, honing, cylinder, "Ammco".
- Machine, milling, Universal.
- Machine, shaping, 14-in.-18-in. stroke (two).
- Machine, woodworking—bandsaw, 26-in.
- Press, hydraulic, 80-ton.
- Plant, welding, electric, transformer type, 7KVA.
- Plant, welding, electric, engine-driven, 150 amp. (four).

*Mataranka.—No. 10 Australian Advanced Workshop—Australian
Electrical and Mechanical Engineers.*

- Lathes, 4½-in. (two).
- Lathes, 5-in.
- Lathes, 7-in.
- Lathes, 8-in., short bed, "Visby" (two).
- Machine, drilling, radial, 32-in.
- Machine, grinding, crankshaft, 72-in., "Norton" (two).
- Machine, boring, cylinder, "Van Norman" (three).
- Machine, boring line, "Tobin Arp".
- Lathe, brake drum truing.
- Machines, grinding, cylinder, Horizontal, "Heald".
- Machines, honing, cylinder, No. 1 (three).
- Machine, milling, Universal, No. 2.
- Machine, remetalling and boring bearings.
- Machines, shaping, 14-in. to 18-in. (two).
- Plants, welding, electric, engine-driven, 150 amp. (two).
- Plants, welding, electric, engine-driven, 300 amp. (two).
- Machine, piston finishing.

686.

BOMB AND MINE DISPOSAL WORK—FIRST-AID PRECAUTIONS.

All officers, petty officers and selected ratings engaged in the disposal of bombs, mines, projectiles and other miscellaneous missiles, as also in work involving the use of explosives, should be instructed in first-aid. This should include instruction in the use of tubonic ampoules of morphia.

2. A first-aid outfit Scale F.1 is to be carried by parties engaged in this work. It contains shell dressings and tubonic ampoules of morphia and will be supplied on demand to the Medical and Dental Store Officer, Medical Store, Royal Edward Victualling Yard, Sydney.

3. The outfit should be left at a safe distance from the job, and as it contains articles of a magnetic material, it should not be brought near the job until the officer is satisfied that no magnetically operated device is present.

(527/211/2107.)

687.

NAVAL STORES IN SMALL VESSELS—RESPONSIBILITY AS TO CUSTODY.

Certain motor patrol vessels were recently transferred from one base to another and appreciable quantities of naval stores were lost from the vessels due to the fact that clear instructions as to the Naval Authority to whom the boats should be delivered were not issued, and, as a result, the vessels and their equipment were not placed on proper custody at the receiving base for some months.

2. Naval Officers-in-Charge are to ensure, in future cases of transfer of small vessels and equipment from one base to another, that the officer making delivery is given clear instructions as to the Authority to whom delivery is to be effected. The Naval Officer-in-Charge of the base from which boats are transferred is to ensure that proper receipts are obtained from the receiving base for the boats and stores therein. The Naval Officer-in-Charge of the receiving base is to ensure that stores are mustered on receipt and both boats and stores placed in proper custody.

(612/207/2865.)

688.

DAMAGE TO SIGNAL FLAGS BY RIGGING INSULATORS.

Reports have been received of damage to signal flags, due to fouling porcelain rigging insulators whilst being hoisted.

2. When vessels are next in hand for renewal of standing rigging, the porcelain insulators are to be repositioned, if necessary, to clear hoists of signal flags.

(603/247/1768.)

689.

INSTRUCTIONS FOR DRIVERS OF NAVAL MOTOR SERVICES—FORM N.M.T. 7.

Some holders of the naval driving licence, Form N.M.T.5, are not fully conversant with the contents of the "Instructions for Drivers of Naval Motor Vehicles", Form N.M.T.7. A comprehensive knowledge of these instructions is essential and must be required of all drivers before naval licences are issued in future.

2. Action is also to be taken to ensure that all present holders of the naval driving licence are familiar with the contents of Form N.M.T.7.

3. Paragraph 7 of Form N.M.T.7 will be amplified, on reprint, to make clear that unauthorized passengers in naval vehicles include naval personnel not detailed for the duty on which the vehicle concerned is engaged or not duly authorized to take passage in the vehicle.

(432/222/1322.)

690.

SOUVENIRS OF ENEMY ORIGIN AND DANGERS ATTENDANT THERETO.

Because of severe injuries, which have occurred among service personnel, caused by delayed explosions in souvenired enemy equipment, a strong warning is issued to all personnel of the Royal Australian Navy serving in the New Guinea and Pacific areas regarding the danger of handling enemy equipment, and of the existence of land mines and booby traps in areas evacuated by the enemy.

2. Attention is also drawn to Navy Order 522 of 1944.

(546/201/511.)

(This Order will be printed for posting on Notice Boards.)

691.

MAGAZINE LOGS—RENDERING.

A number of cases has occurred recently where magazine logs forwarded by H.M.A. ships have not been received at Navy Office.

2. In view of their contents, magazine logs are to be regarded as confidential documents. They are to be forwarded by registered post and Navy Office advised by memorandum of their despatch.

(659/203/575.)

692.

COMPLETION OF MEDICAL AND REHABILITATION FORMS FOR DISCHARGED PERSONNEL.

The provisions of Navy Order 336 of 1943 are to apply in future to all personnel about to be discharged, irrespective of whether they are being invalided or not, and in order to simplify the completion of medical and rehabilitation forms the following procedure is to be carried out.

2. Members to be discharged P.U.N.S. or B.N.P.S.

(a) At the time of medical survey, Forms A.M. 146z and A.M. 301z (see Navy Order 510 of 1944) are to be completed, together with the invaliding Survey Form A.M. 252z, Form A.M. 146z being enclosed in the medical history documents and forwarded to Navy Office with the survey. X-ray examination of the chest is to be carried out before the survey is held unless exceptional circumstances render this impracticable.

(b) Where the member requires to be discharged to his home port, Form A.M. 146z and medical history documents are to be forwarded, after return from Navy Office, to the medical officer of the member's home port depot, while the member's Form A.M. 301z is to be forwarded by the rehabilitation officer of the depot in which the survey has taken place to the rehabilitation officer of the depot from which the discharge is to be effected.

3. Members discharged for non-medical reasons.—Members are to be referred to the medical officer at such a time prior to discharge as will permit medical examination to be conducted without haste and in sufficient time to allow result of chest X-ray to be recorded on Form A.M. 146z. If any disability likely to have restrictive effects on his employment is discovered in a member, it is to be noted on his Form A.M. 301z in terms of the code index system, the use of which was promulgated in Navy Order 510 of 1944. In any case the form is to be forwarded to the rehabilitation officer as soon as possible.

(835/201/48.)

