

04.02
29850

DEPARTMENT OF REFERENCE

OH-02

ACCESSION
NUMBER

29850

29850

RESTRICTED.

COMMONWEALTH NAVY ORDERS

I N D E X

OF

NAVY ORDERS

1945

COMPRISING

NAVY ORDERS ISSUED BETWEEN

1st JANUARY, 1944, and 31st DECEMBER, 1945

and

LIST OF NAVY ORDERS CANCELLED

SUBSEQUENT TO 1st JANUARY, 1939.

(This Index is published at the end of each half-year.)

DEPARTMENT OF DEFENCE

LIBRARY
Photo-lithographed, by Authority:
J. J. GOURLEY, Government Printer, Melbourne.

CLASS
NUMBER

04.02

ACCESSION
NUMBER

29850

I N D E X

Subject	C.N.O. or O.C.N.O. No.
A	
A.A. Armament - H.M.S. Frigates	†9/45
Fire Control - Calibration Procedures for A.B.U. and Type 285	†225/44
Targets - Kites and Drogues for - Discontinuance of Supply	148/44
Able Seamen - R.A.N.V.R. - Allocation to General Service ..	176/44
Abnormal Expenditure - Accumulators	181/44
A.C.B. 247 (R) Issue	†85/44
A.C.F. Club for Women Officers in Sydney	164/45
Access to Compartments situated below the waterline which are to be manned at sea	255/44
Accidents - Guns	28/44
- Naval Motor Vehicles	58/44
- Revolvers	86/44
Accommodation - Rail - Adelaide to Melbourne	97/44
- R.N. Dominion and Allied Naval Personnel - Charge for	214/45
Accountant Branch Examinations	648/44
Ratings - Temporary Commissions	366/44
Accounting for Machinery, Machine Tools, etc. supplied for Naval Workshops	108,584/44
Naval Armament Stores, at certain Shore Establishments - Instructions	151/45
Stores in stations and/or services attached to H.M.A. Depots and Bases	515/45
Procedure - Lubricating Oils	506/45
Naval Armament Stores in D.E.M.S.	315,615/44
Store - Frigates	244/44
Accounts and Storekeeping Arrangements - Naval - Respons- ibility for inspection	99/45
- Armament Store - H.M.A. Ships etc. - Consumable Stores	285/44
for Provisions - Necessity for prompt payment ..	217/44
Supplied to Tenders when absent from Parent Ship	585/44
- Naval Armament and Torpedo Store - Errors and omissions, etc	612/44
- Pay and Service Certificates - H.M.A. Ships attached to Eastern Fleet	57/44
- R.A.N. Destroyers and A.M.S. attached to Eastern Fleet	415,512/44
Acting Higher Rank - Retention	452,650/44
Petty Officers - Irregular wearing of Class III Uniform Q.R.Is (S.U)	106/44
Rank or Relative Rank of Lieut-Commander - Naval Reserves - Grant	607/44;10,41,141/45
Action Rations	645/44
Repair and Fire Fighting Materials - Stowage - Minor War Vessels	†179/44
Adaptometer - A.R.L. Mk.III - Classification of Night Vision by	345/44
Addresses - Postal - New Guinea Area	297,584/45
Seaward Defences	595/45
Administration - Landing Ships	†208/44
Admiral Sir Guy Royle - Valedictory	292/45

† Denotes C.C.N.O.

C.N.O. or
O.C.N.O. No.

Subject

A - contd.

Admiralty charts in H.M.A. Ships - Correction of	362/45
Admission of Naval Personnel to Mental Hospitals or Receiving Houses	160/44
Advance Supply Notes - Despatch of for Naval Stores shipped etc. from H.M.A. Naval Store Depots	642/44
Advancement of Communication Ratings in (or attached to) Combined Operations	557/44
Engine Room Artificers	555/45
P.O.s on Repatriation - A.F.O. 106/45	282/45
Ratings - Notation of seagoing recommendations on Conduct Sheets and Notations on A.S.264	465/45
Serving in Services Reconnaissance Department, Far Eastern Liaison Office and Allied Intelligence Bureau Trained in Combined Operations ..	667/44
	279/45
Recovered Deserters to Able Seamen of equivalent rating	26/44
Wiremen	556/44
to Chief Petty Officer - R.A.N.R. Petty Officers Shipwright - Qualifications	290/44
	322/44
Petty Officer and Leading Seaman - Professional Examination	241/45
- Radio Mechanic Branch	560/44
- W.R.A.N.S.	259/45
- W/T Ratings	275/44
	175/44
Advances - Cash - for Fighting French Warships	168/44
Aerial - Radar - Y.F.P. - Modifications	
- Training System A/S1 and A/S5 - Modification to Radar Types A272, A286 P/Q	181/44
- Trunk - 4-in - W/T - A.M.S. Vessels	260/45
Agencies - Commonwealth Savings Bank - Commission	85/44
Aircraft Operating from H.M.A. Ships - Emergency Rations	67,445/44
Airgraphs	547/45
Air Mail - India - United Kingdom	565/44
Mails	620/44
or Sea Freight - Stores consigned by - to Northern Operational Bases	167/44
Sea Rescue Vessels - Allocation of Names	412/44
- Physical Standard of Personnel	558/44
Allocation of Radar Equipment	142/44
R.A.N.V.R. Able Seamen to General Service	176/44
Allowance - Captain of Heads	258/44
- Dependant for children over 16 years receiving full-time education	585/45
- Dragnets	256/45
- Lodging	585/45
- Marriage and Child - Sterling Payments	76/45
- Mileage - Private Medical Practitioners attending members of the Forces	5/45
- Store - "Bathurst" Class Australian Minesweepers	14/45
Allowances of Accessories - Authorized (Test Equipment) for Australian Type Radar	140/44
Cartridges S.A. .503 - Revised	1257/44
- Star Shell	128/44

† Denotes C.C.N.O.

Subject

C.N.O. or
C.C.N.O. No.

A - contd.

Alteration(s) and Addition(s) - A.M.S. Vessels - A.F.O.589/45	152/44
- Asdio Installations - Firing of Shell Plating - C.A.F.O. 2163/45	1102/44
- Fitted for Mine-sweeping - Spur for Additional Signal Halliards	1118/44
- Hailing Equipment - A.F.O.3963/43	1108/44
- Stiffening of Seatings - Kelly and Lewis Steam driven Generators	1104/44
- Voice Pipe Communications	1105/44
	1173/45
- "B" Type M.Ls.	
- Depth Charge Pattern Control Introduction	1121/44
- Fairmile Patrol Boats Type "B"	1195,1229/44
	- C.S.A.
Smoke Apparatus and Type "F" Smoke Floats	1209/44
- Firefighting in H.M.A. Ships A.F.O. 5595/45	197/44
- Items	63/45
- Range Transmitter from Radar to Transmitting Station	546/44
- Steam Auto clave for Sterilization of Dressings etc. in H.M.A. Frigates and H.M.A. Ships "Warrego" and "Swan"	181/45
- Ventilation	179/45
- 72 ft. H.D.M.Ls. ex U.S.A.	1256,1291/44
- 80 ft. H.D.M.Ls.	1115/45
Amendment to "Official Memorandum - Prices of Clothing, etc. maintained for issue on repayment to Ships' Companies" - dated 1st May, 1945	51/44
of Form A.S.151 - Consumable Naval Store Ledger Sheets	246/44
Amendments - Quarter Bills	189/44
Ammunition - American 40 mm.- Fitted Tracer Igniter Mark 10 - Danger from Ejection	18/45
20 mm.- Assembled with defective primers - Unserviceable lots	356/45
- Boxes C222 and C199	2,278/44;70,86/45
- Carriers - Quadruple Q.F.4 in - Modification	423/45
- Cartridges, 40 mm. Bofors H.E. with Primers No.18 - Withdrawal - Report	580/44
- Clip Mark 3 - American - Stoppages	209/45
- Expenditure Returns - Monthly	1271/44
- Gun Armament Material - Failure - Form S.1148	294/44
- Lighters - Loading for ocean passages	1199/44
- Miscellaneous A.A.D. Weapons - Rails, Propelling Rocket U2 in Mk.II	42/44
- Propelling Rockets U2 in Mk.II and III, Kirby Lots 32,53,136,178,179 and 182 - Restriction	152/44

† Denotes C.C.N.O.

Subject

C.N.O. or
C.C.N.O. No.

A - contd.

Ammunition - contd.

- Outfits of Small Ships - Arrangements for Periodical Exchange, Examination etc	525/44
- Packages - Empty - Return	587/45
- Practice - 40 mm. Bofors	†56/45
- Pyrotechnics and Rockets, Signal - Star Shell - All Calibres - Minimum Range at which satisfactory functioning can be expected	195/44
- Q.F. 40 mm. Bofors Ready Use - H.M.A. M.Ls	189/45
- Reconditioned Q.F. 2-Pdr. H.E.H.V.	†145/44
- Small Arms - Allowances for Shore Bases	†66,†101/45
- Stock Reports	166/44
- Supply to Northern Bases	†145/44
- Unserviceable American - Disposal	†78/44
- Restricted or Repairable - Disposal	258/45
- Weekly Report of Stock - by Shore Establishments on Form A.O.5Z	326/44
- 2 pdr - Unhooking of Links	505/45
- 4" - Hand up Chutes for - Modification	†180/44
- 40 mm. Bofors - Policy in regard to issue	655/44, 50/45
- 20 mm. Oerlikon - Clearing Charges	151/44
- 20 mm. and 2-Pdr. - 20 mm. Oerlikon H.E. - Liability to Caps of Cartridges Blowing Out, when modified Breech Face Piece (Mark II) are fitted - Withdrawal of certain lots - Reports	142/44
- 20 mm. Oerlikon H.E. Lot H.N.C.15 - Withdrawal	509/44
N.F.E.404 - Withdrawal	510/44
T.P.C.746 - Withdrawal	487/44
Tracer Lot N.F.H.2257 F - Withdrawal	507/44
10B/45 - Withdrawal	508/44

A.M.S. Vessels - Additional Kit Lockers	†41/44
- Aerial Trunk - 4 in. W/T	260/45
- Allocation of Engineer Officer's Cabin	95/45
- Alterations and Additions	†164,†251/44
- A.F.O.589/45	†52/44
- Asdic Installations - Fairing if Shell	
Plating - C.A.F.O.	
2165/43	†102/44
- Depth Charge Throwers	
Mark II Replacement by	
Mark IV - C.A.F.O.	
1964/45, paragraph 2(a)	†86/44
- Fitted for Minesweeping - Spur for Additional	
Signal Halliards	†118/44
- Fitting of D/F Equipment	
A.W.A. Type	
C.143A	†85/44
Single Bofors	
Mountings	†176/44
- Hailing Equipment -	
A.F.O.5965/45	†108/44
- Lockers for Fire-fighting and Action Repair	
Materials	†65/44

† Denotes C.C.N.O.

Subject

C.N.O. or
C.C.N.O. No.

A - contd.

A.M.S. Vessels - Alterations and Additions - contd.

- Stiffening of Seatings - Kelly and Lewis Steam Driven Generators	†104/44
- Voice Pipe Communications	†105/44
- and Frigates - Modification to Evaporator System	†68/44
- Arrangements for Cafeteria Service - Modifications to Galley	125/45
- A/S Type 128 or 128A where fitted - conversion to A/S Type 128B or 128C	159/44
- Axial Flow Fans	12/45
- Bridge Communications for A/S work	†76/45
- Brown Type "A" Gyro Compass	590/44
- Canvas Flag Wallet	114/44
- Close Range Armament when single Bofors is fitted	†205/44
- Contamination of Boiler Feed Water with Oil Fuel	275/44
- Deterioration of Cast Iron Condenser Doors	11/44
- Exchange of Ammunition	520/44
- Fitting of Rocket Flare Projectors	†140/45
- Gardner Diesell Engines for "L.L." Sweeps - Circulating Water Header Tanks	479/44
- Guard Rail Stanchions on Forecastle	†166/44
- Gunnery Communications	†7/44;†40/45
- Hawsers	168/45
- "L.L." Cable Drums - Stiffening of Hand Winding Gear	545/44
Lead - Modification	†258/44
Sweep Reel - Failure of Hand Winding Gear	559/44
- Magazines - Battens - Reports	579/45
- Main Circulating Water Inlet Pipes	518/44;95/45
- Maxim Continuous Power	†162/44
- Modification of - to Steam Driven Boiler Room Fans	195/44
to Firemain at Station 54	570/44
- P.A.C. Projectors	†151/44
Rockets	88/44
- Paying off, into Reserve of Extended Notice	†172/45
- Peacock and Smith Evaporating Plants	126/45
- Pitting in Engine Room Bilges	†69/44
- Propeller Shafts	†62/44
- Radar	†9/44
- Gyro Compass Repeats	†41/45
- Refrigerating Plant for Cold Room	210/44
- Refit at Port Adelaide - Replenishment of Naval Stores	54/44
- Removal of Helmsman's Splinter Proof Shelter	†204/44
Oropesa Minesweeping Winches	†153/45
- Repainting	110/44
- Replacement of 20 mm. Overlikons Mk.IIIA by Mk.VIIA	227/45
- Shortening of Main Mast	†80/45
- Signalling Projectors	†169/45
- Stability	†177/44
- Removal of Excessive top weight before carrying out As and As	†154/45
- Steel Chests	182/44

† Denotes C.C.N.O.

Subject

A - contd.

C.N.O. or
C.C.N.O. No.

A.M.S. Vessels - oontd.		
- Use of Fore Peak for Trimming Ship	†45/44	
- Ventilation of Wardroom Pantries	†89/44	
to forward Magazine	†114/45	
- Vibration of Steam Driven Boiler Room Fan Engine	†125/44	
- 57/3 Cells for "L.L." Sweeps	†8/44	
Anchor Cable - Additional Securing Arrangements for "B" class M.Ls.	†72/45	
Annual Census - Office Machinery	22/44	
Inspection of Explosives ex H.M.A. Ships	111/44; 50/45	
Anti-Aircraft Targets - Kites and Drogues - Discontinuance of		
Supply	146/44	
-Cholera - Inoculation	673/44	
-Flash Gear	51/45	
-Gas Clothing - Oilskin - Upkeep and Repair	21/44	
- Eyeshields and Ointment - Revision of Allowances	209/44	
- Protection	549/44	
- Respirators - Care	79/45	
- Painting of Haversacks	582/44	
- Personnel on Draft	545/45	
- Glare Spectacles - Pattern 4074 - Supply	30/44	
- Polarised Sun Glasses -		
Replacement	281/44	
-Malarial Measures for Operational Forces destined for		
service in malarious area	418/44	
- Supply of Stores	15/44	
-Ship Fire Control - Communications - Radar Observation of		
fall of shot	†259/44	
-Submarine measures - Secrecy concerning	†111/45	
Torpedo Branches - Amalgamation	586/45	
Apparatus A.D. Type "L"	22/45	
Applications from Naval Personnel for Discharge	205/44	
Appointment(s)	316,677/44;	
	334,351,452/45	
- Inspector of Naval Recruiting and Chief		
Rehabilitation Officer	456/45	
- Medical Editor	374/45	
- Port Division Naval Medical Officer - Geelong ..	622/44	
- Where date is to be reported - Reports	352/44	
Apprentices - War Service	291/44	
Armament - Additional - Gate Vessels and Boom Working Vessels ..	†57/44	
- Close Range - Frigates Nos.1-8 - As. and As. ..	†160/45	
- Depot, Fremantle - Title of Officer-in-Charge ..	84/45	
Maribyrnong - Title of Officer-in-Charge	352/45	
Naval Depot, Brisbane	†147/45	
Darwin	†135/45	
- H.M.A. Ships - Additional Fitting	†46/44	
Material and Ammunition - Failures - Rendering of		
Forms S.1148 (h), (i) and (j)	294/44	
- Store(s) - Accounting at certain Shore Establishments -		
Instructions	151/45	
Accounts - H.M.A. Ships paying off	460/45	
- Expenditure - Return	342/45	
- Issued by U.S. authorities	224/45	
- Matters - Naval - Correspondence on -		
Naval Officer-in-Charge, Brisbane	174/44	
- Return of Gunmounting and Torpedo -		
H.M.A. Ships paying off	445,529/45	
- Returned by H.M.A. Ships - Vouchering	328/45	
Arms, Small - Accounting	†124/45	
- Establishment for Shore Bases	†20/44	

† Denotes C.C.N.O.

Subject

A - contd.

C.N.O. or
C.C.N.O. No.

Army Medical Facilities - Use in Transfer of Invalids	641/44	
Salvage Service - Salvage of Condemned, Unserviceable		
etc. Stores	267/44	
Arrangements in respect of the Agreement between U.K. and		
Australian Governments for H.M. Ships transferred to R.A.N.		
for manning	†51,227/44	
Arrival of Commissioned Ships - Expected Times	446/45	
Artificer and Artisan Branches - Class Advancement	298/45	
A/S and Radar Maintenance Vessels - Naming	†198,†260/44	
Directing Gears; Pattern A.810 - Types 126 and 144 Series ..	†185/44	
Equipment - Half-yearly Reports on - Record of Personnel ..	†148/44	
in M/Ls - R/T Interference	61/44	
Installations - Modification Stores	†99/45	
- Night Marker, Pattern 16213 - C.A.F.O.622/44	†25/45	
- Tuning	†62/45	
Recorders - Dessicators	†12/45	
Sets fitted with electrical training brushes for motors		
Patt. 9955 and 9956	†263/44	
Type 128 or 128A where fitted - A.M.S. Vessels - Con-		
version to A/S Type 128B or 128C	†139/44	
Staff - Base - Organization	363/45	
Training - Ships fitted with types 144Q-147B	†151/45	
W/T. Radar, etc. Equipment - Establishment Lists	311/44	
Asdic Installations Types 144/5 - Training of Personnel	†70/44	
Sets in H.M.A. Frigates and H.M.A.S. "Orara" and "Kybra" ..	†183/44	
Stores - Packages containing - Marking	†98/44	
Assistance for War Correspondents - Publicity	184/45	
Atebrin - Suppressive treatment (Prophylaxis) for Malaria ..	240/44	
Aural care and selection of Submarine Detector Ratings	391/44	
Australian Army Canteens Service Issuing Points	484/44; 54/45	
Defence Canteens Service Clubs	47/44	
Minesweepers "Bathurst" Class - Store Allowance	14/45	
Red Cross Society	544/44	
Authorized allowance of accessories (Test Equipment) for		
Australian Type Radar	†140/44	
Automatic Morse Operators and T/P Visual Signallers, Coders -		
W.R.A.N.S. - Advancement	2, 53, 128, 204/44	
Awards, Decorations and Honours to Naval Personnel	200, 268, 515, 679/44;	
	146/45	

B

Badges - Controlled and Observation Mining Ratings	7/44	
- D.E.M.S. Gunnery Ratings	95, 358/44	
for War Service	237/45	
- Service, R.A.N.R. - Deprivation and Restoration	61/44	
- Officers' Cap	257/45	
Ball and Robber Bearings - Procurement	4/44	
Band Instruments - Orchestral - Percentage Charge and Grants-		
in-Aid	197/44	
Bandsmen - Employment in lieu of R.C. ratings - allowance A.F.O. 909/45	285/45	

† Denotes C.C.N.O.

Subject

B - conti.

	C.N.O. or C.C.N.O. No.
Bank Agencies - Commonwealth Savings - Commission	85/44
Base Spares - Propellers and Tailshafts	371/44
Batteries for L.L. Sweep - Care and Maintenance	†150/45
- Low Power - Mounting on Resilient Mountings in order to reduce effects of shock	†252/44
- Main Low Power - Increased capacity	†276/44
Beach Unit - R.A.N. Mail Address	548/45
Beacon(s) - Radar	†141/44
- Euston Reef - Radar Reflector	†119/44
Beckets - Reeving of - Clips Cartridge No.25	164/44
Bed Linen - Clothes Rationing	185/44
Bedding for W.R.A.N.S.	169,218,586/44
- Wartime Allowances - R.A.N. Shore Establishments	469/44
Beer - Supply to H.M.A. ships and Naval Establishments	326,552/45
Bilges - Pitting in Engine Room - A.M.S. Vessels	†69/44
Bills of Lading and Consignment Notes - Return of Receipted "Extra" copies	195/45
- Quarter - Amendments	189/44
Binoculars - for D.E.M.S.	252/44
- Precautions regarding security before use	196/45
- Telescopes, Watches and Heliographs - Muster	597,595/44
Blankets and Mess Gear - Issue to Personnel travelling	254/45
Bofors - Guns - Care and Maintenance	165/44
- Improved Unloading Mask	42/45
H.E. Ammunition - Cartridges 40 mm. - Fitted with Primers No.18 - Withdrawal, Report	580/44
O.Q.F. 40 mm. - E.F.C. valves	578/44
- Pitting of Standard Grid Sights - Single Mountings	129/45
- Liquid in Recoil Buffers	311/45
- Locking of Screws, Securing Bracket Supporting Buffer - Fitting of Shock-proof Washers	466/44
- Series Inspection	67/45
- Springs Striker Inner and Outer	222/45
Q.F. 40 mm. Ready Use Ammunition - H.M.A., M.Ls.	189/45
40 mm. - Ammunition - Policy in regard to issue Practice	655/44;30/45
Mk.I and I* (Naval) Aust. Manufacture	486,577/44
- Modification - Breech Casing right front	439/44
- Cartridge Deflector	431/44
- Left Rear of Breech Casing	435/44
- Safety Lever Indicator	432/44
Mark IIIA Gun Mountings - Modification of earlier Pattern Pedestals	228/45
- Position of ready use racks Patt.7100	512/45
- Single - Supply of Sights Correctional 40 mm. A.A. Mtgs.	150/45
- Mk.V Aust.	57/45
- Slewing Handles to be Fitted	450/44
Single Mountings Fitting of Standard Grid Sights	550/45
Boiler Blow Down System	359/45
Feed Water - Contamination by Oil Fuel - A.M.S. Vessels	275/44

† Denotes C.C.N.O.

Subject

B - conti.

C.N.O. or
C.C.N.O. No.

Boilers - Combustion Cones for - Permanent Naval Stores	91/44
Water - Hydrometers, sensitive Glass - Pattern 37A	187/45
Tube - Use of Shore Water	†161/44
Bombs and Mines - Disposal Work - First Aid Precautions	686/44
Books and Forms	55,78,102,129,185,198,247,268,299,341,358,359,388,422,470,481,511,523,554,573,602,616/44;7,37,46,75,159,190,225,275,361,451,455,508,598/45
Local Secret and Confidential - (See Local Secret and Confidential Books)	
Printed Matter etc - Disposal in H.M.A. Ships Paying off	571/45
Boom Defence Depots - Establishment at Cairns, Townsville, Port Kembla and Port Moresby	58/44
Boots - Football - Amended Issuing Price	556/44
- Rubber Sea - Oilskin Clothing - Storage	245/44
Boxes Ammunition C.222 and C.199	2,278,416/44;70,86/45
W.76 and W.76E	71/45
B.R. and O.U. Books Account	600/44
797 - Handbook on Lockouts and Service Optical Instruments - 1945 - Amendments	340/44
810/1945 (Late O.U.5409) - Rate Book for Naval Stores	597/45
826/45 and B.R.861/45 - Drill for Fuse-keeping clock	24/45
Branch-Coding	16/44
- Pass Professional Examination	60/44
Branches - Ordnance and Electrical Mechanic	82/44
Breathing Apparatus, Pattern 3485 - Salvage Self-contained	98/45
Breech Mechanism - Modification to O.Q.F. 4'7" Mk.XII, XII* and XIIIB	579/44
Bridge Chart Table-Modification - Escort Vessels fitted with Radar	†154/44;†51/45
Communications for A/S work in A.M.S. vessels	†76/45
Bright Steel Bolts, Nuts and Studs, manufactured from Marbrite Free Cutting Steel	594/44
British Naval Office, San Francisco	8/45
Pacific Fleet Supply Office - R.A.N. Destroyers	265/45
Broadcast Receivers - Commercial Types	615/44
Bursaries for children of personnel killed or disabled during the War	420/45
Business Member - Naval Board of Administration	105/44
Butter, Concentrated, Hardened - Replacing Butter Fat Spread - Economy in consumption	563/44
Butts for .503" Vickers Machine Guns on Single A.A. Mounting	115/44
	477/44
Camp Stretchers - Wooden Folding - Replacement	125/45
Canned Meats - Warranty period	68,255/44

† Denotes C.C.N.O.

Subject

C - contd.

Subject	C.N.O. or C.C.N.O. No.
Canteen arrangements in H.M.A. ships and establishments ..	469/45
Canteens - Service System - in Frigates and A.M.S. vessels ..	446/44
- Rendition of Reports on paying off ..	572/45
- Stores for H.M.A. ships	198/45
- Supply	285/44
Canvas Flag Wallet for A.M.S. vessels	114/44
Hose Tubing - Prolonging life	92/44
Cap Badge(s) - Officers'	257/45
Caps - Blue for officers and men proceeding to the United Kingdom.	46/44
Captain of Heads Allowance	258/44
Carriers - Ammunition, Double, for O.Q.F. 4" Mk.XIX and O.Q.F. 4" Mk.XVI*	528/44
Cartridges B.L. 8" Cordite - Low Muzzle Velocity	515/45
- Cases - Q.F. 4" XVI* Gun - Withdrawal	44/44
- Marking with Sub-Lot XJ	54/44
- M.L.9.5 in D.C.T. Cordite H.S.C.T. -154-055, 4-oz. Mk.XII -	475/44
Introduction	65/44
124/058, 3-oz.14 drms. Mk.II - Withdrawal	95/44
- S.A., Ball 9 mm. of D.I.L. manufacture - Restriction	407/45
Oerlikon - Prematures	188/45
.455" Ball, Revolver - Mark II - withdrawal	194/45
- M.Q.25/12/42 - Withdrawal	514/45
- Signal 1 in. Green Mk.XII - Restriction:	96/45
White Mk.IXT. of M.E. Filling - Lots	580/44
8-16 inclusive - Withdrawal	59/45
- 40 mm. Bofors H.E. fitted with Primers No.18 - With- drawal - Reports	584/45
Case Markings - Shipment of Mining Stores	775/44
Cash Advances in American Currency from B.P.F. units to R.A.N. Authorities - Rate of Exchange	505,675/44
to Fighting French Warships	545/45
H.M.A.Ships from U.S. Ships	150/44
Canadian Ships	78/44
Vouchers and Forms - Captain's Signature	25,98,177/44;
Cells - L.L. 57/5 - For L.L. Sweeps - A.M.S. Vessels	215,242,578/45
Censorship - Naval	22/44
Census Annual - Office Machinery	190/44
Certificates - Disposal on Reversion - R.N. Ratings on Loan to the R.A.N.	256,519/44
- Naval Watchkeeping - Naval Reserve Officers	75/44
- P.M.G. - Examination for - Eligibility of Tele- graphist Ratings for Exemption in certain subjects	568/45
- Service	57/44
and Pay Accounts - H.M.A. Ships attached to Eastern Fleet	419/45
Transfer - N.A.P. to R.A.N.V.R.	217/45
Cessation of Hostilities in Europe	190/44
Chart Folios - Establishment in H.M.A. Ships	182/44
Chests - Steel, for A.M.S. Vessels	219/44
Chevrons for War Service	290/44
Chief Petty Officer - Advancement - R.A.N.R. Petty Officers	322/44
Shipwright - Advancement - Qualification	61/45
Chlorosulphonic Acid Mixture Drums - Precautions to be observed when returning	

† Denotes C.C.N.O.

Subject

C - contd.

Subject	C.N.O. or C.C.N.O. No.
Chocolate and Confectionery for Naval Canteens	408/44
and Messes	158/44
Cholera - Inoculation against	†149/44
- Precautions against	4/45
Christmas Fare 1945	577/45
Chronometers and Watches for Navigational Use	541/45
Chutes - Hand-up for 4" Ammunition - Modification	†180/44
Cigarettes and Tobacco - Naval Personnel proceeding on Leave or Discharge - Supply	82,506/45
Cinema Branch - Adoption in the R.A.N.	202/45
Claim Forms for Compensation - for total loss of uniform clothing - ratings - introduction of Forms A.S.105I and A.S.105Z	242/44
Claims for Pilotage	5/45
Clasp to Good Conduct and Long Service Medals - R.A.N. and R.A.F.R.	597/45
1939-45 Star	56/45
Classification of Night Vision by A.R.L., Adaptometer (Mark III) - Security	345/44
Clearing Charges - Ammunition - 20 mm. Oerlikon	†205,411/44
Clips Cartridge No.25 - Reeving of Beckets	151/44
No.1 Mark I	164/44
- Inglefield and Unserviceable Flags - Return to Store	559/44;229/45
Clothes Rationing	69/44
Clothing and Uniform - W.R.A.N.S. - Gymnastic Shoes	650/44
- Civilian - Supply to members of the Naval Forces on Discharge	19/44
- Issues - Special - for Personnel in forward island areas	224,282,495/44;89/45
- Maintained for issue on repayment to Ships' Companies - Amendment to official memorandum	51/44
- Oilskin Anti-Gas - Upkeep and Repair	21/44
and Rubber Sea Boots - Storage	245/44
- Prices - Maintained for issue on repayment to Ships' Companies - Official Memorandum	285/44
- Protective	251/44;156/45
- Rationing - Bed Linen	185/44
- Repayment - in Tenders	492/44
- Supplies and Uniform - Repayment Issues of Materials	171/44
- Repayment - Tenders	165/45
- Supply to civilian crew of R.A.F.A. "Kurumba"	240/45
Clubs - A.C.F. for Women Officers - Sydney	164/45
- Australian Defence Canteens Service	47/44
- Golf - Honorary Membership - Victoria	485/45
- Naval, Military and Air Force - Adelaide	178/45
Coal for H.M.A. Ships - Procedure governing supplies	52/44
Coastal Craft - Reports of Proceedings	†19/45
- Section - Formation	652/44;77,204/45
Code - Ammunition etc - for signalling requirements	†275/44
and Cypher Machines - Installation in H.M.A. Ships	†112,†288/44
Coders, Visual signallers, T/P and automatic morse operators, W.R.A.N.S. - Advancement	204/44
Coding Branch	148/45
- Pass Professional Examination	60/44
- Re-examination for ordinary coder	16/44
Machines and spare parts - Transport	†24/44
Gold Room - Refrigerating plant for A.M.S. vessels	210/44
Colonial Service - Post War Opportunities	470/45

Denotes C.C.N.O.

Subject

C - contd.

	C.N.O. or C.C.N.O. No.
Combined Operations - Advancement of ratings trained in	279/45
- Section - Senior Naval Officer	513/44
Combustion Cones for Boilers - Manufactured from heat resisting steel	127/45
- Permanent Naval Stores	91/44
Comforts forwarded to H.M.A. Ships and Establishments - Acknowledgment	606/44
Commander - Qualification for promotion to - Officers promoted direct from Warrant Rank to Lieutenant	11/45
Commendations by Commander-in-Chief	†54/45
Commission - Commonwealth Savings Bank Agencies	85/44
Commissioned Ships - Expected times of arrival	446/45
Commissioning of H.M.A. ships, etc (see H.M.A.S.)	
Commissions - Temporary - Accountant Branch Ratings	566/44
- Coder Ratings	414/44
- Selection of ratings from Lower Deck	474/44
- Engineering Branch	219/45
- Special branch R.A.N.V.R.	200/45
Commodore Commanding His Majesty's Australian Squadron	554/45
Commonwealth Legal Service Bureau	629/44
Reconstruction Training Scheme	670/44;115/45
Savings Bank - Agencies	85/44
Communicable Diseases - Introduction to New Guinea and Australia	†254/44
Communication(s) - Depth Charge	†21/44
- Flags - British - U.S.	159/45
- Ratings - Non-substantive rates	324/45
- Wavemeter Outfits	291/45
with the Press	155/44
Compass distances - Safe - Infringement	†149/45
- Gyro - Repeats for Radar in A.M.S. vessels	†41/45
- Magnetic - Effect of Telephones	355/44
- Sperry Mk.XIV Mod.I Gyro - Incorrect Fitting of Trans- mitter Connecting Cables	314/44
Compassionate Drafts	†194/45
Compensation for Loss of Tools	184/44
Total Loss of Uniform and Clothing - Officers and Ratings	561/44
Components of Admiralty Type Radar	†282/44
Compulsory making of Wills	220/44
Concession Messages to Naval Personnel	326/45
Railway Fares of Service Personnel travelling in uniform and paying their own fares	645/44
Travel - for members of the Forces - in N.S.W.	535/44
Condemned, Unserviceable etc. Stores - Salvage - Army Salvage Service	267/44
Condensed milk - Unsweetened - Batch Markings	564/45
Confidential and Secret Correspondence - Security	†99/44
Correspondence - Registration	500/44
Messages - Transmission in plain language over Teletprinter Channels	98,155/44
Navy Orders - Issue	†1/44
Reports on Naval Reserve Officers	427/44;40/45
Confirmation and Promotion of Naval Reserve Officers	301/44
Provisional promotion for R.A.N.R. and R.A.N.V.R. officers in time of war	681/44

† Denotes C.C.N.O.

Subject

C - contd.

	C.N.O. or C.C.N.O. No.
Consumable Naval Store(s) Ledger Sheets - Amendment of Form A.S.151	246/44
- Naval Armament Stores Account - H.M.A. Ships, etc.	585/44
Consumption of Butter - Economy	115/44
Contract(s) Rates - Fresh Provisions - At Melbourne	101/44
Supply of Ratings' Made-to-Measure Uniforms	405,508/44;121,467/45
W.R.A.N.S. Ratings' Made-to-Measure Jackets and Shirts	406,628/44;120,466/45
Control Gear and Electrical Switch - Mounting on Resilient Mountings to reduce effects of shock	†242/44
of Venereal Disease - Melbourne Area	†40/44
- Prophylactic Centres	†152/44
Controlled and Observation Mining Ratings - Badges	7/44
Controller of Naval Demobilization	418/45
Convalescent Home for Women's Services	284/44
Convoy Escort Organization	†51/44
Plotting Board	†251/44
Signal Ratings	104/45
Cooks - W.R.A.N.S. - Galley Shoes	77/44
Cordage - Precautions to prevent deterioration	154/45
Cordite Landing	90,180/44
Records - Maintenance on Board H.M.A. Ships Temperature returns and Sub-lot Markings - R.A.F.As. Auxiliary A/S and M/S vessels and M.Ls.	89/44 51/45
Correction(s) to Local Secret, Confidential and O.U. Books	†170,†182,†189,†200, †215,†235,†283/44; †22,†47,†67,†91,†108, †126,†166,†175,†181/45
Correspondence and Signals for F.O.I.C. and Admiral Superintendent, Sydney	521/45
- Commodore Commanding H.M.A. Squadron - Address	591/45
- H.M.A. Radar School	441/44
- London	604/44
- Naval Store Depot, Melbourne	35/45
on Naval Armament Store Matters - Naval Officer- in-Charge, Brisbane	174/44
- Orderlies and Postmen	259/44
- Secret and Confidential - Instructions re - Acknowledgment, custody, disposal, etc	†56/44
Corrigendum to Navy Order 528 of 1945	226/44
24 of 1944	96/44
54 of 1944	151/44
66 of 1944	105/44
71 of 1944	116/44
169 of 1944	218/44
266 of 1944	589/44
412 of 1944	463/44
523 of 1944	574/44
666 of 1944	16/45
146 of 1945	201/45
†294 of 1945	†18/45
345 of 1945	373/45
601 of 1944	389/45
337 of 1945	389/45
559 of 1945	399/45
525 of 1945	601/45
Cots - Stretcher - Pattern 474 - Supply	245/44
Counter - Measures to Acoustic Homing Torpedo - F.X.R.Gear	†120/44

† Denotes C.C.N.O.

Subject
C - contd.

Counterpanes, Coverlets and Mattress Covers - Return to Store of numbers held in excess of Allowance	598/44
Coupons - Food - Naval Personnel	440/45
- Special Issue for purchase of Nightwear - R.A.N. Women's services	565/45
Course and Examination for Chief Ordnance Artificer	451/44
Courses - Navigation	59/44
Cremation of deceased service personnel	325/44
Crests of H.M.A. Ships - Supply to British Centre Hyde Park	594/45
Custody of Keys of Safes and Chests in small Ships	†52/44
Customs duties on goods sent or brought to Australia by Personnel - Remission	154,364/45
Cylinder Liquid - Test of Recoil - Gun Mountings	192/44
Cylinders - Gas - Contractors' - Return	99/44
- Empty - Return	48/44
for Industrial Gases	262/44
- Water Pressure Test	295/44:60/45
Cypher and Signal Logs - Disposal	†44/44
Machines - Type "X" and Mark III	†180/45

D

Damage control and firefighting school	375/45
to Mail received at Milne Bay	437/44
Darwin and Thursday Island - Period of shore service	680/44
Naval Armament Depot	146,†212/44
Base Organization	255,372/45
Torpedo Depot	†56/45
Deafness due to Gunfire - Recording in Medical Officer's Journals	672/44
Deaths - Information to be forwarded where personnel die from disease or injury	229/44
Deceased Personnel - Letters found amongst effects	56/44
Service personnel - cremation	325/44
Defences - Seaward - Addresses	595/45
Deferred Pay of mobilized personnel	27/44
Degaussing Ranges	477/45
Delegation of Authority - Supply of Spectacles	297/44
Ministers Powers under National Security Regulations	390/45
Demands for Dry Provisions in Darwin, New Guinea and Moluccas Areas	426/45
Demobilization Forms	429/45
Requests - Medical Officers	19/45
Demolition Stores - Electrical - Withdrawal	571/44
D.E.M.S. - Binoculars	252/44
- Gunnery Equipment - Painting	550/44
Ratings - Badges	95,538/44
- Ratings, Drafting records, etc.	320/44

† Denotes C.C.N.O.

Subject
D - contd.

Dental and Medical facilities in the New Guinea Area - R.A.N.	†272/44
Treatment for R.N. personnel	171/45
Work - Quarterly return	655/44
Dependants of members of the Forces who have married abroad - Passages to Australia	592/44
Depth Charge(s) and Associated Stores - Weekly Stock Reports	†72,†135/44
- Care and Maintenance	414/45
- Chutes - Modification to method of securing to Deck - Motor Launches	†16/44
- Repositioning - M.Ls.	152,†184/44
- Communications	†21/44
- Dropped for Practice	13/45
- Equipment - Modification to Parbuckle Stowage for - Mk. I D.C. throwers	†138/45
IV D.C. throwers	458/45
- Expenditure, six months ending 31st December 1943 - Analysis	†42/44
30th June -	†181/44
1944 - Analysis	†33/45
31st December 1944	†141/45
30th June, 1945	28/45
- Gassing	†106/44
- Mark VII - VII* Filled Minol	†188/44
- Minimum speeds for firing Depth Charge Patterns	†277/44
- Minol filled - Allocation	121/44
- Pattern Control - Introduction - Alterations and Additions	188/44
- Patterns - Minimum Speeds for Firing	284/45
- Pistols - Chests Testing Sets	145/44
- History Sheets - Details required	94/44
- Form O426	27/45
- Mark VII - Modification to Mk.VII* VII* Reg. No.4614	684/44;210/45
- Restrictions on issue	415/44
- Plugs Wood, Primer - Tube Stamp, No. 6053	165/44;69/45
- Practice Expenditure	†122/44
- Primers Mk.VII Lot 532 - Withdrawal	398/45
- Thrower(s) - Mark II - Replacement	†25/44
- Pistols M.L. 9.5" - Use of correct description	532/44
IV - O.M.L. 9.5 in.	†21/45
- Securing Strap - Supply of Spare Wire Spans	581/44
- Modification of Tumbler Hook	371/45
- Pistols - Spare	60/44
- Type (M) and Depth Charges Mark VIII - Defective Bungs Charge Case	196/44
- Use in shallow waters	†261/44
Deserters - Recovered - Advancement	26/44
Dessicators for A/S Recorders	†12/45
Despatch of Naval Armament, Gunmounting and Torpedo Stores to Melbourne	45/44
Personnel to Ships and Establishments in New Guinea Area	450/44
Sydney for Medical Observation or treatment not requiring Hospitalization	258/44

† Denotes C.C.N.O.

Subject	C.N.O. or C.C.N.O. No.
D - contd.	
Destroyers and A.M.S. attached to Eastern Fleet	413/44
Detention Barracks - Military - Uniform and Clothing of Ratings or Imprisonment - Maintenance of wives and children of members of the Forces undergoing	556/44
Deterioration of cast iron condenser doors - A.M.S. vessels	558/45
Detonators - No.25, Mark I - Withdrawal	11/44
- Percussion, watertight, Mark VII Lot 141 B.R.8/41 - Withdrawal	100/44
D/F and W/T charging resistances	41/44
Diaphragms I.R. - to be fitted to Depth Charge Pistols	†51/45
Directing Gear - A/S Sets Type 128 and 144 Series	29/44
Director of Women's Royal Australian Naval Service	†185/44
Discharge - Applications from Naval personnel for	17/45
from R.A.N. on account of physical unfitness for service	205/44
Discharged Naval Personnel - Rehabilitation Procedure	599/45
Discrepancies in stores shipped reports A.D. 690 and O.9	14/44
Disease - Communicable - Introduction of in New Guinea and Australia	51,560/44
Disposal of Cypher and Signal Logs	†234/44
Effects of R.A.N. personnel reported dead, missing, P.O.W. sick	†44/44
Mines rendered safe	409/45
Notebooks containing Secret or Confidential matter	251/44
Obsolete and Unserviceable Films - Instructional Films	†176/45
Unserviceable American ammunition	296/44
Restricted or Repairable - Disposal	†78/44
Divers - Selection of Ratings	258/45
Diving Equipment	149/44
Non-Substantive Rating	†105/44
Draft - Medical examination prior to	565/44
Drafts - Compassionate	120/44
Drafting of Personnel - Malaria control	†94/45
- W.R.A.N.S.	118/44
Dragnets - Allowance	159/44
Dress, Officers'	256/45
Drill Tunics with Blue Facings	†30/44
Drogues and Kites for Anti-Aircraft Targets - Discontinuance of Supply	71/44
Duke of Gloucester's Standard and Governor General's Flag - Flying of	146/44
	140/45
E	
Ear, Nose and Throat Specialist - Consultant	26/45
Eastern Fleet - H.M.A. Ships attached to - Service Certificates and Pay Accounts	57/44
Economy in consumption of butter	115/44
Education and Vocational Training - Director	619/44

† Denotes C.C.N.O.

Subject	C.N.O. or C.C.N.O. No.
E - contd.	
Educational Service - R.A.N. - Reconstruction Training Scheme	602/45
Test 1 - Results - September 1945	81/44
- December 1945	205/44
- March 1944	318/44
- June 1944	475/44
- September 1944	668/44
- December 1944	147/45
- March 1945	500/45
- June 1945	457/45
- Higher - R.A.N. - Results - October 1945	156,248/44
- April 1944	459/44
- October 1944	25/45
Electric Fans - H.D.M.Ls.	279/44
Electrician and Ordnance Mechanic Branches	82/44
- Equipment in motor launches - Replacements	362/44
- Switch and Control Gear - Mounting on resilient mountings in order to reduce effects of shock	†242/44
Eligibility of telegraphist ratings for exemption in certain subjects of the examination for P.M.G. Certificates	75/44
Emergency rations for aircraft operating from H.M.A. Ships	67,445/44
Transmitter - Receiver in Frigates	†58/45
Water ration for personnel at sea - Supply of water bottles	156/44, 6/45
Empty Gas Cylinders - return	48/44
Enemy Ammunition	585/44
Equipment	522/44
War Material and Explosives Stores - Packing and Transport	†75/45
Engine Register - M.Ls.	162/44
Room Bilges - Pitting - A.M.S. vessels	†69/44
Ratings - Examination - Results - September 1945	15/44
- March 1944	344/44
- September 1944	105/45
Watchkeeping Certificates	501/45
Engine Officer's Cabin - A.M.S. vessels	95/45
Engines - Internal Combustion - Preparation for stowage, etc after removal from boat	682/44
Equipment - A/S in M/Ls. - R/T interference	†61/44
- Diving	105/44
- Fire Fighting - Trials - Reports	161/44
- I.F.F. - Return of Type A.B.K. sets to store on re- placement by Radar Type 255	†96/44
- Life Saving - Red Distress Signals and Benzadrine Tablets	†154/44
- Sleeves and Torches for Inflatable Lifebelts	126,212/44
- Radar - Allocation	†142/44
- Test - A.M.S. vessels	†14,†71/44
- U.S.N. Type Radar - Spares	†55/44
- Web - Pattern 1957	157/44
- W/T Testing - for Frigates	194/44
Escort Organization - Convoy	†51/44
Refresher Training Organization	†55/44
Vessels fitted with Radar - Modification to Bridge Chart Table†154/44;†51/45
Establishment Lists - W/T, A/S, Radar etc Equipment	511;502/44
of Chart Folios - H.M.A. Ships	†190/44
Establishments - H.M.A. Shore - Name Ships	270/44
of Small Arms for Shore Bases	†20/44
- R.A.N. - Naval Stores	625/44

† Denotes C.C.N.O.

Subject

C.N.O. or
C.C.N.O. No.

E - contd.

Euston Reef Beacon - Radar Reflector	†119/44
Evaporating Plants - Peacock and Smith - A.M.S. vessels	128/45
Evaporator Systems - Modifications to H.M.A. Frigates	†150/44
Examination(s) - conuodt (non-service)	245/45
for Petty Officer Writer and Supply Petty Officer	575/44
the rank of Paymaster Lieutenant-Commander, R.A.N.	202/44
Lieutenant-Commander(s)	182/45
of Engine Room Ratings	555/44
- Results - September, 1943	15,191/44
- March, 1944	344/44
- September, 1944	105/45
- March 1945	299,354/45
Sick Berth Staff - Results - November, 1943	104/44
- May, 1944	458/44
- November, 1944	18/45
- May, 1945	577/45
- W.R.A.N.S.	250/45
- Professional - for advancement to Petty Officer	
and Leading Seaman	241/45
Warrant Engineers and Warrant	
Mechanicians	334/44;245/45
Writer and Warrant	
Supply Officer	553/44;244/45
Executive Officers - Radar Courses	†115/44
Expenditure - Abnormal - Accumulators	181/44
- D.C. - Six months ending 31st December, 1942 -	
Analysis 1943	†42/44
on behalf of Netherlands - Classification	187/44
Explosives ex H.M.A. Ships - Annual inspection	111/44;50/45
- Periodical Examination	277/44
- Storage in buildings other than Magazines or Ex-	
plosive Stores	569/44
Extended Leave or Furlough - Members being Demobilized	570/45
Extra Duty Allowance not payable - R.A.N. Women's Services	253/45
Extractors - O.Q.F. 4-in. Mark XVI* Guns	†11/44
Eye Shields - Anti-Gas - and Ointment - Revision of Allowances	209/44

F

Failure of Armament material and ammunition - rendering of Forms	
S.1148(h), (i) and (j)	294/44
Gun Armament material and ammunition	144/44
Failures - P.A.C. Rockets	3/44
Fairmile Patrol Boats Type "B" - Alterations and Additions	†195,†229/44
- C.S.A. Smoke Apparatus	
and Type "F" Smoke	
Floats	†209/44
Rudders	293/44
Type "B" Motor Launches - Slipping	12/44

† Denotes C.C.N.O.

Subject

C.N.O. or
C.C.N.O. No.

F - contd.

Fan Engine - Steam Driven Boiler Room - Vibration - A.M.S.	
Vessels	†125/44
Fans - Electric - H.D.M.Ls.	279/44
- Steam Driven Boiler Room - Modification to A.M.S. vessels	195/44
Table, for Sick Bays of H.M.A. "Tribal" Class Destroyers etc	395/45
Fares - Concession Railway - Service personnel travelling in	
uniform and paying their own fares	645/44
of Relatives attending funerals of deceased service personnel -	
payment	274/44
Feed Pumps - Weir Type	504/44
Water treatment - U.S. Navy System - Adoption in the R.A.N.	525/45
Fenders - Wattle Rod	280/44
Fighting French Warships - Cash advances	†75/44
Filling Recoil Cylinders - 4-in. Gunmounting Marks XXIII and	
XXIII*	145/44
Films - Instructional - Disposal of obsolete and unserviceable	
films	296/44
- Training, and Film Strips held on board - Return	74/45
Firearms - Landing in Australia	355/45
Fire and smoke risks in H.M.A. Ships, reduction of - Types of	
Paint to be used for interior painting	569/44
Control arrangements - H.M.A. Frigates	
Extinguishers for Motor Launches	124/44
- Recharging of Cylinders for "Nuswift",	
"Groviner" and "Essex" Type	659/44
Fighting and Action Repair Materials - Stowage - Mincr	
War Vessels	†179/44
- Applicators - Provision	480/45
- Equipment - H.D.M.Ls. and Other Small Craft	261/45
- Life Lines	58/45
- Trials - Reports	161/44
in H.M.A. Ships - Alterations and Additions -	
A.F.O.5393/45	†97/44
School	664/44
Precautions	†146,285/45
in cinema projection rooms	221/45
Prevention in Motor Boats - Wearing of protective clothing	573/45
Naval Storehouses	596/45
Firemain at Station 54 - Modification - A.M.S. vessels	370/44
First Aid Medical Kits	70/44
Fitting of Additional Armament in H.M.A. Ships	†46/44
Flag(s) Lockers	135/45
on Commonwealth Buildings	6/44
- Precautions to be taken in washing	537/44
- Unserviceable and Inglefield Clips - Return to Store	69/44
Wallet - Canvas, for A.M.S. Vessels	114/45
Flashless Propellant	†144/44
Flotanets - Lifesaving Equipment	132/45
Flour	368/45
- Tax, refund	459/44
Food Coupons - Naval personnel	266,605/44
Rationing and Food Economy - General Instructions	265/44
- Wastage	†16/44
Football Boots	536/44
Foresights - 40 mm. Bofors Gun Mountings	548/44
Form A.D.495 (Report of Docking) and Form A.D.488 (Propellers	
etc) - Procedure	307/45
A.M.2Z - Prevention of Disease and Maintenance of Health	
in Tropical Climates	539/44

† Denotes C.C.M.O.

Subject

F - contd.

C.N.O. or
C.C.N.O. No.

Form - contd.

A.M.47Z - Medical History Document Record Card	519/45
A.M.114Z - Report of Seasickness	449/44
A.M.177G - Medical Store Account for Scale "C" Medical Store	222/44
A.M.501Z - Medical Status of Personnel recommended to be invalided - Introduction	547,510/44
A.S.5 - Cash Advances or Transfers	450/45
A.S.103Y and A.S.105Z - Introduction	242/44
A.S.151 - Consumable Naval Store Ledger Sheets - Amendment ..	246/44
A.S.155X - Record of Naval Store Ledgerkeepers - Introduction	298/44
A.S.559Z - "Long Leave Book"	9/44
A.S.542 - Routine Order and Travelling Expenses Claim	509/45
A.S.1099 and A.S.1099B - List of Naval Stores on Permanent Loan etc	359/45
N.A.5 - Consecutive Number of paid voucher to be inserted by Paying Office	255/44
N.M.F.7 - Instructions for drivers of Naval Motor Services ..	689/44
O.426 - History Sheets for D.C.Pistols	94/44
S.102 and 103 - Records of issue and return of loan clothing	601/44
S.1147A - Quarterly return of temperature of storage of Cordite - Non-rendering	†100/44
S.1148	421/44
- Rendering, and return of Defective Stores	565/45
S.1404 - Return of B.L. and Q.F. Guns - Rendering	589/45
Forms and Cash Vouchers - Captain's signature	150/44
- Books - see Books and Forms	
- Demobilization	429/45
- Medical and Rehabilitation - Completion for Discharged Personnel	692/44
- Printed	409/44
Forwarding of C.W.1 Forms	79/44
Free Kits - Issue to Ratings on entry	154/44
Freight and travelling warrant books - Disposal	659/44
Fremantle - Torpedo Depot	†65/44
Fresh Provisions - Contract Rates - at Melbourne	101/44
Water supplies in H.M.A. Ships	658/44
Frigates and A.M.S. vessels - Modification to Evaporator System ..	†68/44
- Emergency Transmitter - Receiver	†58/45
- H.M.A. - Modification to Evaporator System	†150/44
- Low Power Supply System	†16/45
- Naval Store Accounting Procedure	244/44
- Special arrangements for oiling at Sea - A.F.O.4159/44	†59/45
- With reciprocating main engines - maximum continuous power	†55/44
Fruit and tomato juices - extra issue	199/45
Fuel Oil - Naval Stocks in Australia	†15/44
Funeral(s) Expenses - Payment of Press Notices	503/45
of deceased Service personnel - payment of fares of relatives	274/44
- Payment of Contractors' claims	250/44
Fumigation of H.M.A. Ships	270/45
Furlough or Extended Leave - Members being Demobilized	570/45
Furniture - Steel - Supply to H.M.A. Ships	556/44
- Wooden - Replacement by Steel, in Cruisers, Destroyers, A.M.S. Vessels and "Warrego" and "Swan"	354/44
Fuzes - No.401, Mark II Lot 146 V.A.O. filled 10/41 - Withdrawal from service for 100 per cent examination	55/44
- Percussion D.A. No.250	52/45

† Denotes C.C.N.O.

Subject

F - contd.

C.N.O. or
C.C.N.O. No.

Fuzes - contd.

- Time Mechanical - Maintenance of Pre-set Fuzes	551/45
No.401 Marks I and IA	153/44
On Board H.M.A. Ships - Annual percentage in wartime	255/44
F.X.R. Gear - Counter measure to Accoustic Homing Torpedo ..	†120/44

G

Galley Shoes for Cooks - W.R.A.N.S.	77/44
Gaols - Civil - Maintenance of United States Naval Personnel ..	113/45
Garbage and ashes from H.M.A. Ships at Outer Harbour and Port Adelaide - Disposal	90/45
Gas Cylinders - Return of Empty	48/44;507/45
Contractors'	99/44
- Water Pressure Test	295/44;60/45
Gases - Industrial Cylinders	262/44
Gassing in Depty Charges	28/45
General Instructions - Food rationing and food economy	265/44
Message of "H" and "I" Series remaining in force	140/44
Generators - Diesel - Exhaust Pipes	428/44
- Stiffening of Seatings of Kelly and Lewis steamdriven - A.M.S. vessels - Alterations and Additions	†104/44
Girl Guides' Holiday Gift to the R.A.N. Patriotic Fund of Victoria	421/45
Good Conduct Badges - Counting of previous service toward award ..	589/44
Service Badges - R.A.N.R. - Deprivation and Restoration	61/44
Government Stores - Misappropriation - Reports to Civil Police ..	72/44
Gowrie Scholarships	52,522,45
Gramophone records suitable for "Doubling Round" - Supply	516,45
Grant of full and modified "Qualified Officer" status in the R.A.N.	74,132/44
Grants-in-Aid and Percentage Charge - Orchestral Band Instruments	197/44
Gratuities - Outfit - on Change of Class of Uniform	250/44
Gratuitous Issues of Uniform and Clothing to British and Allied Services	661/44
Gratuity, Outfit - Lieutenant (Emergency or Retired) - Payable on promotion from commissioned warrant officer or warrant officer	211/44
Officers of the Naval Reserve Forces	566/45
War - to Members of the Naval Forces	525/45
Greatcoats for Naval Chaplains - Supply	660/44
Grids for Eye Shooting Sights, for close Range Weapons - In- creased Allowance	150/45
Guard Rail Stanchions on Forecastle - A.M.S. Vessels	†166/44
Gun Armament Material and Ammunition - Failure	144/44
Drill - Q.F. - Care in loading to avoid damage to Fuzes	461/45
Mountings - Test of Recoil Cylinder Liquid	192/44
Trials - Procedure	38/44
- Reports - Elevating and Training Efforts	529/44
- 4-inch Gunmounting Marks XXIII and XXIII*	†57/44

† Denotes C.C.N.O.

Subject	C.N.O. or C.C.N.O. No.
G - contd.	
Gunmountings - 4-inch Marks XXIII and XXIII* - Filling Recoil Cylinders	143/44
Gunnery Communications - A.M.S. Vessels	†7/44;†40/45
Equipment - D.E.M.S. - Painting	350/44
- Trials	†78/45
Instructional Centre - Status - Sydney Command	266/45
Practices in small ships	252/45
Ratings - D.E.M.S. - Badges	95,558/44
Guns and Gun Mountings - Bofors - Care and Maintenance	105/44
- 40 m.m.- Foresights	548/44
- Mk.IIIA - Modification of earlier Pattern Pedestals	228/45
- Lewis and Savage Lewis .303 in.- Magazines 97 Rounds fitted with lengthened catch	29/45
- Machine .303" Bren and .303" Vickers G.O.- Modification to Mag- azines and Repair Magazine Main Springs	394/44
Mark I - Springs Return - Exchange	49/45
- Lewis - Conversion of Mk.IV Sights (100 Knots) to Mk.V (200 Knots) and Fitting of Mk.III Butt Plate ..	352/44;211/45
- Vickers G.O. - Modifica- tions to prevent wrong assembly on Single A.A. Mountings - Butts	477/44 595/44
Oerlikon	595/44
- Oerlikon - Mark II and IV - Collapse of Barrel Springs Mk.I ..	350/44
- 20 m.m.- Adaptor for cleaning rods - introduction	505/44
- Locking of Barrels ..	179,549/44
- Spare Appurtenances, etc.- Basic Sets ..	530/44
- O.Q.F., 4 inch XVI* - Extractors ..	†11/44
- Q.F. 3 in. 20 cwt. Mk.I, IB - IE Pins Axis Breech Mechanism Lever Catch Mk.I to be replaced by Mk.II ..	351/44
40 m.m. - Method of testing blow of striker	306/44
2 pdr. Mk.XIV Guns and 40 m.m. Rolls Royce Mountings - Disposal ..	20/45
- Report of Stock and Transactions ..	445/44
- Single 40 m.m. Bofors Mk.IIIA - Supply of sights correctional 40 m.m. A.A. Mtgs Mk.V (Aust)	57,130/45
- 2-pdr. Mk.XIV Replacement in "B" Type M.Ls. by 3-pdr. Mk.V and 2-pdr. Mk.VII*	442/44
- 4-in. XIX, Re-arming with, on H.A.L.A. XXIII* Mounting - H.M.A.Ships ..	260/44
- 4-in. Mark XXIII and XXIII*	208,592/44
- Elevation Buffer Stop - Replacement of Spring by Dis- tance piece	372/44

† Denotes C.C.N.O.

Subject	C.N.O. or C.C.N.O. No.
G - contd.	
Guns and Gun Mountings - 4-in. Mark XXIII and XXIII* - contd.	
- Firing Gear - Modification to Catch Piece	574/44
- Lower Elevation Gear Box - Fitting of Leather Washer	575/44
- Lubrication of Centre Pivot	566,657/44
Sub-Calibre Q.F. 2 pdr. L.A. Mark I - Supply for use in Q.F.4-in. Mk.XVI* Guns	514/45
Gymnastic Shoes for W.R.A.N.S.	19/44
Gyro Compass (Brown Type "A") - Replacement of 2 mfd. condensers in transmission Spark Quench Circuit	590/44
Equipment, Mark XIV - H.M.A.Ships	†50/45
Repeats for Radar in A.M.S. Vessels	†41/45
- Sperry Mod.I Mk.XIV - Condensers - Follow up Circuit - Incorrect filling of transmitter connecting cables	579/44 514/44
- Mercury Ballistic Caps	378/44
- Oiling of Upper Vertical Guide Bearing	376/44
- Repeater Bezel Screws	377/44
Gun Sights - Housing Oerlikon Guns fitted with Mk.XIV - Mk.IV - Fitting to Mk.VIIA Oerlikon Mountings ..	254/44 †165/44
- Wiring changes to provide standby conditions	†11/45
- U.S.Mk.XIV	†253/44
- Change of wiring to provide stand- by conditions	†161/45
H	
"H" and "I" Series - General message remaining in force	140/44
Hailing equipment - A.M.S. Vessels - Alteration and Addition Item C.A.F.O. 5963/43	†108/44
Half-yearly reports on A/S Equipment - Record of personnel	†148/44
Hall Scott Defender Engine(s) Fuel	†77/45
Oil Cooler Cores	206/45
Handbook on Lookouts and Service Optical Instruments - B.R.797 (1943) - Amendments	340/44
Hand Tools - Co-ordination of Common User Items	340/45
Hand-up Chutes for 4" Ammunition	†180/44
Haversacks - Painting - Anti Gas Respirator	382/44
Hawsers for A.M.S. Vessels	168/45
Haze Screens - R.A.N. Pattern - Modification	154/44
Health - Prevention of disease and maintenance of health in tropical climates	559/44
Heat Treatment of Shuttle Valves of Reciprocating Pumps	107/44
Hedgehog Projectiles - Landing	239/45

† Denotes C.C.N.O.

Subject

H - contd.

Heliographs, Binoculars, Telescopes and Watches - Muster	..	397/44
Helmets, Steel (R.A.C.) Mk.I - Introduction	..	97/45
Higher Educational Test - Results - October, 1943	..	156,248/44
- April, 1944	..	439/44
- October, 1944	..	25/45
- April, 1945	280/45
History of the War - Naval Medical	..	73/44
Sheets - Depth Charge Pistol - Details required	..	145/44
- Form O.426	..	94/44
H.M.A. Frigates and H.M.A.S. "Orara" and "Kybra"	..	†183/44
H.D.M.L. 1161 - Paying off	..	†50/44
1322 - Commissioning	..	†18/44
1323 - Commissioning	..	†19/44
1324 - Commissioning	..	†137/44
1326 - Commissioning	..	†23/44
1328 - Commissioning	..	14/45
1329 - Commissioning	..	†139/44
1338 - Commissioning	..	†129/44
- Paying off	..	553/45
1339 - Commissioning	..	†110/44
1340 - Commissioning	..	†278/44
- Paying off	..	521/45
1341 - Commissioning	..	†278/44
1342 - Commissioning	..	†173/44
1343 - Commissioning	..	†227/44
1346 - Commissioning	..	†10/45
- Paying off	..	496/45
1347 - Commissioning	..	†2/45
1352 - Commissioning	..	†109/44
- Paying off	..	544/45
1353 - Commissioning	..	†236/44
1354 - Commissioning	..	†285/44
1357 - Commissioning	..	†255/44
1358 - Commissioning	..	†244/44
1359 - Commissioning	..	†220/44
801 - Commissioning	..	†138/45
802 - Paying off	..	491/45
803 - Paying off	..	492/45
806 - Paying off	..	472/45
807 - Paying off	..	493/45
813 - Paying off	..	457/45
817 - Paying off	..	473/45
825 - Paying off	..	494/45
825 - Commissioning	..	†29/44
826 - Commissioning	..	†4/44
- Paying off	..	543/45
827 - Commissioning	..	†91/44
- Paying off	..	†269/44
H.D.M.Ls. ex U.S.A. - Fitting of Twin Vickers .505" Mountings -	..	455/44
Alterations and Additions	..	†68/45
M.L. 428 - Commissioning	..	†187/44
430 - Paying off	..	†48/45
431 - Commissioning	..	†157/45
M.S.L. 701 - Commissioning	..	†119/45
705 - Commissioning	..	†128/45
706 - Commissioning	..	120/45
707 - Commissioning	..	121/45
708 - Commissioning	..	38/45
Radar Training Establishment	..	

† Denotes C.C.N.O.

Subject

H - contd.

H.M.A. Ships - Additional officers borne for Training	..	92/45
and Establishments - Mail	..	114/45
- Photographic material	..	8/44
- Reduction in Kits	..	241/44
Attached to Eastern Fleet - Service Certificates and	..	
Pay Accounts	..	57,440/44
- Coal - Procedure governing supplies	..	32/44
- Code and Cypher Machines - Installation	..	†112/44
- Emergency Rations for Aircraft operating from	..	67.445/44
- Establishment of Chart Folios	..	†190/44
- Firefighting in - Alteration and Addition -	..	
A.F.O. 5393/45	..	†97/44
- Fitted with Mk.XIV Gyro Compass Equipment	..	†50/45
- Fitting of additional armament	..	†46/44
- Fuzes, Time, on Board - Annual Percentage landing in	..	
Wartime	..	253/44
In Harbour - Anti-Sabotage Measures	..	†76/44
- Maintenance of Upper Deck Fitting	..	178/44
- Paying off	..	553,593/45
- Procedure - See Paying off H.M.A. Ships	..	
- Provisions supplied by U.S. Navy Supply Ships and	..	
Depots	..	133/45
- Radar Stores	..	131/45
- Re-arming with 4" XIX Guns on H.A.I.A. XXIII* Mounting	..	260/44
- Reports of Proceedings	..	†97/45
- Signatures of Issuing Officers on Travelling Warrants	..	674/44
- Sun Reflecting Device	..	33/44
- Supply of Steel Furniture	..	356/44
- Ventilation	..	454/44
- Zinc Sheets and Underwater Protection of Ships	..	
and Fittings	..	517/44
Shore Establishments - Name Ships	..	†590/44
Store Carriers - Loading	..	†95/45
H.M.A.S. "Adelaide" - Commissioning	..	†84/45
- Paying off	..	†43/45
"Air Bird" - Commissioning	..	†60/45
"Air Chief" - Commissioning	..	†186/44
"Air Clan" - Commissioning	..	†286/44
"Air Cloud" - Commissioning	..	†246/44
"Air Faith" - Commissioning	..	†23/45
"Air Hope" - Commissioning	..	†29/45
"Air Host" - Commissioning	..	†245/44
- Renaming	..	†70/45
"Air Master" - Commissioning	..	†201/44
"Air Mercy" - Commissioning	..	†39/45
"Air Mist" - Commissioning	..	†216/44
"Air Rest" - Commissioning	..	†218/44
"Air Sailor" - Commissioning	..	†254/44
"Air Save" - Commissioning	..	†217/44
"Air Sense" - Commissioning	..	†42/45
"Air Speed" - Commissioning	..	†38/45
"Air Spray" - Commissioning	..	†27/45
"Air Trail" - Commissioning	..	†28/45
"Air View" - Commissioning	..	†265/44
"Air Watch" - Commissioning	..	†274/44
"Air Wave" - Commissioning	..	†215/44
- Renaming	..	†69/45
"Alatna" - Commissioning	..	†28/44
"Alexander Thompson" - Paying off	..	†267/44

† Denotes C.C.N.O.

X CNO's listed various ships not included herein.

Subject

H - contd.

H.M.A.S. - contd.

"Alfie Cam" - Paying off	†158/44
"Allenwood" - Paying off	†249/44
"Allura" - Commissioning	†111/44
"Amchine" - Paying off	540/45
"Anaconda" - Commissioning	†85/45
"Arcadia" - Commissioning	†6/44
- Paying off	†109/45
"Arista" - Paying off	†92/44
"Avonita" - Paying off	553/45
"Barcoo" - Commissioning	†17/44
"Bataan" - Commissioning	†92/45
"Bermagui" - Re-commissioning	†5/44
"Birchgrove Park" - Re-commissioning	†159/45
"Black Snake" - Commissioning	†3/45
- Paying off	553/45
"Bombo" - Commissioning	†27/44
"Bonthorpe" - Paying off	35/45
"Boonoooro" - Paying off	†75/45
"Burdekin" - Commissioning	†178/44
"Burrabra" - Paying off	†127/44
"Caroo" - Paying off	†6/45
"Carpentaria" - Commissioning	85,101/45
"Coombar" - Paying off	537/45
"Diamond Snake" - Paying off	502/45
"Durraveen" - Paying off	534/45
"Emilea" - Paying off	†66/44
"Falie" - Paying off	518/45
"Fauro Chief" - Paying off	†159/45
"Flying Cloud" - Paying off	404/45
"Geelong" - Paying off	†237/44
"Gilolo" - Commissioning	486/45
"Gippaland" - Paying off	†126/44
"Goolgwai" - Paying off	520/45
"Goonabee" - Paying off	†156/44
"Gunbar" - Re-commissioning	†132/44
"Harman" - Commissioning	188/44
"Hawk" - Paying off	434/45
"Hawkesbury" - Commissioning	†154/44
"Hoona" - Paying off	†165/44
"Huon" - Paying off	547/45
"Jester" - Paying off	196/44
"John Hardy" - Paying off	488/45
"Jon Jim" - Paying off	†279/44
"June" - Commissioning	†76/44
"Kanimbla" - Commissioning	†171/44
"Karina" - Commissioning	†273/44
- Paying off	538/45
"Kiama" - Commissioning	†22/44
"King Bay" - Paying off	†54/44
"Koorine" - Paying off	415/45
"Korowa" - Paying off	435/45
"Krait" - Commissioning	†77/44
"Kuranda"	236/44
"Kweena" - Paying off	†60/44
"Lachlan" - Commissioning	†26/45
"Ladava" - Paying off	582/45
"Larrakia" - Paying off	†49/44
"Larus" - Commissioning	†290/44

† Denotes C.C.N.O.

Subject

H - contd.

H.M.A.S. - contd.

"Laurabada" - Paying off	†104/45
"Limicola" - Commissioning	†226/44
"Limosa" - Commissioning	†253/44
- Paying off	489/45
"Lolita" - Paying off	†105/45
"Lorne" - Renaming	†65/45
"Lucy Star" - Paying off	475/45
"Lusair" - Commissioning	100/45
- Paying off	546/45
"Lysander" - Paying off	542/45
"Madang" - Commissioning	228/44
"Marlean" - Paying off	†254/44
"Matoma" - Paying off	†94/44
"Mary Cam" - Paying off	553/45
"Melinga" - Paying off	401/45
"Medea" - Paying off	†86/45
"Mercedes" - Paying off	†87/45
"Metafele" - Paying off	†171/44
"Miramar" - Paying off	†129/45
"Mischief" - Paying off	416/45
"Misima" - Paying off	487/45
"Mother Snake" - Paying off	531/45
"Mulcra" - Paying off
"Mitipa" - Paying off	†109/45
"Narani" - Paying off	†192/44
"Nepean" - Paying off	†266/44
"Nyanie" - Paying off	17/46
"Nyroca" - Paying off	†110/45
"Olive Cam" - Paying off	553/45
"Orara" - Paying off	†7/45
"Pandion" - Commissioning	†191/44
"Parkes" - Commissioning	†124/44
"Pedare" - paying off	†114/44
"Pioneer" - Paving off	†130/44
"Rathane" - Paying off	†93/44
"Resurgum" - Paying off	†159/44
"River Snake" - Commissioning	†34/45
- Paying off	530/45
"Rushcutter" - Organization	53/45
"Sagittas" - Paying off	†109/45
"Samuel Benbow" - Paying off	535/45
"Sea Mist" - Paying off	536/45
"Seeka" - Paying off	†144/45
"Sleuth" - renaming	109/45
"Sprightly" - Commissioning	†39/44
"Steady Hour" - Paving off	†49/45
"Sterna" - Commissioning	†93/45
"Stingray" - Paying off	519/45
"Strahan" - Commissioning	†59/44
"Summit" - Paying off	†160/44
"Sundowner" - Paying off	†157/44
"Sylph" - Paying off	†95/44
"Taipan" - Paying off	510/45
"Tasma" - Paying off	†43/44
"Terka" - Paying off	†61/45
"Three Cheers" - Commissioning	†247/44
"Tiger Snake" - Commissioning	†202/44
- Paying off	532/45

† Denotes C.C.N.O.

Subject

H - contd.

C.N.O. or
C.C.N.O. No.

H.M.A.S. - contd.					
"Tongkol" - Paying off	†151/44
"Topsy A" - Paying off	†101/44
"Tringa" - Commissioning	†53/45
"Valangen" - Paying off	†85/44
"Vigilant" - Commissioning	†90/44
- Re-naming	285/44
"Viking" - Re-naming	286/44
"Wangalere" - Paying off	539/45
"Wangola" - Paying off	†174/44
"Watcher" - Paying off	†103/45
"Westralia" - Commissioning	†5/44
"Westwind" - Paying off	†268/44
"Wato" - Paying off	541/45
"Watson" - Commissioning	110/45
"Whang Pu"	†84/44
"Winter" - Paying off	444/45
"Wongalere" - Paying off	†125/44
- Re-commissioning	†155/44
"Yunnan" - Commissioning	†214/44
H.M.A. Submarine "K9" - Paying off	†67/44
Victualling Depots	342/44
- Darwin - Re-establishment	468/45
H.M.S. "Alert" - Commissioning	435/45
"Beaconsfield" - Commissioning	†57/45
"Furneux" - Commissioning	†64/45
"Golden Hind"	†252/44
"Nabaron" - Commissioning	†15/45
"Nabbington" - Commissioning	†5/45
"Nabthorpe" - Commissioning	†4/45
"Pepys" - Commissioning	411/45
"Woolloomooloo" - Commissioning	†127/45
<i>16/4/45</i> "Yaroma" - Commissioning	405/45
H.M. Ships transferred to R.A.N. for Manning - Arrangements in respect of the Agreement between the U.K. and the Australian Governments	†51,227/44
Hoist Pusher 8-in.	94/45
Homing Torpedo - Acoustic - Counter Measures to - F.X.R. Gear	†120/44
Honours, Awards and Decorations - R.A.N. Personnel 200,288,515,679/44;146/45	
1939-45 Star, Africa Star, Atlantic Star, Italy Star, etc.	400,517/45
Hooks Sling Universal and Slings Rifle - Use	62/45
Hose Tubing - Canvas - Prolonging Life	92/44
Hospitality for Personnel on leave at Sydney - Command Amenities Liaison Officer	177/45
Hospitals - Australian Service - R.N. Personnel	157/45
- Private - Approved - Rates of treatment for Naval Officers	203/45
- R.A.N. - Treatment of Netherlands Forces	205/45
Housing Oerlikon Guns fitted with Mk.XIV Gyro Sights	254/44
Hydrometers - Boiler Water - Sensitive Glass, Pattern 37A	187/45
Hygiene and Sanitation - General - including the prevention of Malaria - Preservation of Health	269/44

† Denotes C.C.N.O.

Subject

C.N.O. or
C.C.N.O. No.

Ian Macdonald Memorial Prize ..	I	365/44;192/45
Identity Cards and Certificates of Service	325/45
I.F.F. Equipment - Return of Type A.B.K. sets to Store on replacement by Radar Type 253	†96/44
Igniters, Torpedo, Mark XI - Lot No.144, Filled S.W.Y.N. 9/41 - Withdrawal	64/44
No.217, Filled B.R.12/41 - Withdrawal	155/44
Illuminating Rockets 3½ lb. - Prematures	40/44
Illumination of Sight Dials - 4" Mark XXIII* Mountings	327/44
Imprisonment or Detention - Members of Forces undergoing maintenance of their wives or dependants	558/45
Income Tax Returns	453/44;330,451/45
India Rubber Washers for Hose Couplings - Use of correct patterns	554/44
- United Kingdom Air Mail	363/44
Indicator Loop Identification Signal Apparatus	†238/44
Industrial Gases - Cylinders	262/44
Infantry, Landing Ships - Administration	†117/44
Inflatable Lifebelts - Torches and Sleeves for - Life Saving Equipment	126,212/44
Influenza Virus Vaccine - Type "A"	153/45
Inglefield Clips and Unserviceable Flags - Return to Store	69/44
Pattern 100 - Defect in manufacture	671/44
Injuries and Wounds by Enemy Action	550/44
Inoculation against cholera	149/44
Inspection - Annual - Explosives ex H.M.A. Ships	111/44;50/45
of Rifles	531/44
Installations - Asdic - Types 144/5 - Training of Personnel	†70/44
Instructions for the Accounting, Custody, etc., of Secret, Confidential, etc. Books	†136/45
Instructors - Visual Training	55/45
Interference - R/T - A/S Equipment in M.Ls.	†61/44
with W/T and R/T Reception - Radar Type A 286 P/Q	†48/44
Internal Combustion Engines - Starting Gear - Precautions	381/45
Interocular Distance - Record	286/45
Introduction of Cartridges M.L.9.5-in. D.C.T. Cordite H.S.C.T.134 - D55, 4-oz. O-D.R.M.S. Mk. XII	†73/44
Invalids - Use of Army Medical facilities in transfer	641/44
Irregular wearing of Class III Uniform - Acting Petty Officers	106/44
Issue A.C.B. 247 (R)	85/44
of Confidential Navy Orders	†1/44;†1/45
Free Kits to Ratings on entry	154/44
Materials - Repayment - Uniform and Clothing Supplies	171/44
Mess Gear and Blankets to Personnel Travelling	170,552/44;
	234/45
Navy Orders	1/44;1/45

J

Journals - Medical Officers'	527/44
Junior Writer and Supply Ratings - Typewriting experience	176/44

† Denotes C.C.N.O.

Subject

C.N.O. or
C.C.N.O. No.

K

Kelly and Lewis steam-driven Generators - Stiffening of Seatings -			
Alteration and Addition - A.M.S. Vessels	†104/44	
Keys of Safes and Chests in small Ships	†52/44	
Khaki Drill Service Dress for Officers	265/45	
King's Regulations and Admiralty Instructions	108/45	
	- Reprint	387/44	
Kit - Authorised - Uniform and Clothing - W.R.A.N.S.	20,55/44;137/45	
Bags, Hammocks etc - Losses during Transport - Labelling and Marking	586,484,577/45	
Lockers - Additional - A.M.S. Vessels	†41/44	
- Medical First Aid	70/44	
of Ratings drafted to Darwin, Thursday Island, New Guinea or other Forward Areas in the South West Pacific	265/44	
- Reduction in H.M.A. Ships and Shore Establishments	241/44	
- Retention on Discharge - Naval Dockyard Police	346/45	
- Variations - Small Blue Kit Bags and Suit Cases	234/44	
Kites and Drogues - for use as Anti-Aircraft Targets - Discontinuance of Supply	146/44	

L

Label Plates - Lifting Appliances on H.M.A. Ships	275/45	
Landing Cordite	90/44	
Craft Signalmen (Sig. L.C.) - Institutions of Higher Non-Substantive Rates	278/45	
of Hedgehog Projectiles	239/45	
Ships - Administration	208/44	
Lanterns - Plywood - Radar Types 271/3, A.272 - Maintenance	†78/44	
Launches - Motor - Engine Register	162/44	
Leading Stoker Courses	516/44	
Leather Sea Boots - Economy	80/44	
Leave and Relief of Personnel - Northern Areas	218/45	
Concession and Other Railway Travelling Warrants	448/44	
Entitlements	504/45	
Extended, or Furlough - Members being Demobilized	570/45	
R.A.N. Women's Services	277/45	
Ledger and Pay Accounts - H.M.A. Ships	467/44	
Pages and Register Forms (Naval Storekeeping)	254/45	
Sheets - Consumable Naval Store - Amendment of Form A.S.151	246/44	
Legal Assistance to members of the Forces - Distribution of Booklet Service Bureaux - Commonwealth	75/45	
Letters - Found amongst effects of deceased personnel	629/44	
Lewis Guns .303-in. - Stripped - Allowances	36/44	
Liaison between Naval and Air Force Officers engaged on convoy protection - Pay arrangements	580/44	
Library Books - Purchase Price Limit	141/44	
Lieutenant Commander(s) R.A.N. - Examination for the rank	145/45	
- Naval Reserves - Promotion of Naval Reserve Officers to rank or relative rank	182/45	
	607/44;39,141/45	

† Denotes C.C.N.O.

Subject

C.N.O. or
C.C.N.O. No.

L - contd.

Lieutenant (Emergency or Retired List) - Outfit Gratuity payable on promotion from Commissioned Warrant Officer or Warrant Officer	211/44	
Life Boat First Aid Equipment - Scale "H"	271/45	
Life Lines - Firefighting Equipment	58/45	
Raft First Aid Equipment - Scale "G"	272/45	
Saving Equipment - Flotants	132/45	
Red Reflector Discs	289/45	
Sleeves and Torches for Inflatable Life-belts	126,212/44	
Rafts - Release	468/44	
Lighters - Ammunition - Loading for Ocean Passages	†199/44	
Linen - Bed - Clothes Rationing	183/44	
Links - Unhooking - Ammunition 2 pdr.	505/45	
Liquor - Supply to H.M.A. Ships and Establishments by Australian Army Canteens Service	538/44	
Listening Watch - Modification - Radar Types A.296 P/Q	†113/44	
"L.L." Cable Drums - Stiffening of Hand Winding Gear - A.M.S. Vessels	545/44	
Sweep Reel - Failure of Hand Winding Gear - A.M.S. Vessels	339/44	
57/3 Cells for L.L. Sweeps - A.M.S. Vessels	†8/44	
Loading of H.M.A. Store Carriers	†95/45	
Loan Issue of Brown Dungaree Combination Suits to Officers	112/44	
Local Secret Confidential and O.U. Books - see Corrections etc.		
Lockers for Damage Control Stores	506/44	
Fire Fighting and Action Repair Materials - A.M.S. Vessels - Alterations and Additions	†63/44	
- Kit - Additional - A.M.S. Vessels	†41/44	
Locking of Barrels - 20 m.m. Oerlikon Guns	349/44	
Log(s) - Cypher and Signal - Disposal	†44/44	
London Correspondence	604/44	
Loop Repair Vessels - Naming	†197/44	
Loran Receiving Equipment	†145/45	
Loss of Pistols, Revolver	18/44	
Tools - Compensation	184/44	
Ventilating Fan	66/44	
Low Power Batteries - Increased Capacity	†276/44	
Mounting on Resilient Mountings in order to reduce effects of shock	†232/44	
Supply System - Frigates	†16/45	
W/T-R/T Installation Type R.C.8	†30/45	
Lubricating Oils - Accounting for	506/45	
and Greases - Standardization and Purchase for H.M.A. Ships "Kybra", "Wilcannia" and "Reserve"	603/44	
	109/44	

M

Machine Guns - Lewis .303" - Conversion of Mk.IV Sights (100 knots) to Mk.V (200 knots) and fitting of Mk.III Butt Plate	552/44	
Tools - Co-ordinate use in Australia between the services	611,685/44	

† Denotes C.C.N.O.

Subject	C.N.O. or C.C.N.O. No.
M - contd.	
Machinery and Plant - Transfer	524/45
- Coding - Transport	†24/44
- Handbook, 1943 - Issue on Repayment	566/45
- Machine tools, etc. supplied for Naval Workshops - Accounting	108,584/44
- Office - Annual Census	22/44
Spares - Organization for the Provision, Storing, etc	666/44;
	176,216/45
- Spare Propellers and Shafts for H.D.M.Ls. etc. - Authorized Establishment	193/45
Made-to-Measure Jackets and Skirts - W.R.A.N.S. Ratings - Contracts for Supply	406/44
Uniforms - Ratings - Contracts for Supply	405/44
Magazine Logs - Rendering	691/44;169/45
Magazines - unlocking	276/44
Mail Address - R.A.N. Beach Unit	548/45
from H.M.A. Ships and Naval Establishments	44/45
in H.M.A. Ships - Transport	525/44
Received at Milne Bay - Damage	437/44
Maintenance and care of Bofors Guns	165/44
Bases on Shore and Repair Ships - Distribution of Personnel	542/44
of Cordite Records on Board H.M.A. Ships	89/44
Fittings - Upper Deck - H.M.A. Ships	178/44
Radar Types 271/3 A.272 Flywood Lanterns	†58/44
Malaria - Control - Drafting of Personnel	118/44
- Including the prevention - Preservation of Health - General hygiene and sanitation	269/44
- Post-Discharge	557/45
- Supply of Stores for measures for prevention and control With Atebrin - Suppressive treatment (Prophylaxis)	15/44
240/44	
Marking of Cartridges with Sub-Lot XJ - M.Ls.	54/44
Packages containing Asdic Stores	†98/44
Markings - Case - Shipment of Mining Stores	216/44
Marriage and Child Allowance - Sterling Payments	76/45
Mats and Table Cloths	457/44
Meals for R.A.N. personnel travelling by troop train	368/44;119/45
Mechanics - Ordnance and Electrical	526/44
Medals) - Long Service and Good Conduct - Clasps	597/45
Ribbons - Wearing with Tropical Dress	312/44
Medical and Dental Facilities in the New Guinea Area - R.A.N.	†272/44
Officers - R.A.N.R. and R.A.N.V.R. - Qualified Status	621/44
Stores - H.M.A. Ships paying off	509/45
- Supply in the New Guinea Area	212/45
Surgical Instruments - Optical or Specialized	464/45
Attendance of W.R.A.N.S. at Melbourne by a female medical practitioner	572/44
Examination prior to draft	120/44
Facilities - use of Army, in transfer of invalids	641/44
History of the War - Naval	73/44
Observation or Treatment not requiring hospitalization - Despatch of personnel to Sydney	258/44
Officer - Naval - Port Division - Appointment	622/44
- Principal - New Guinea - Duties	18/45
Officers' Journals	527/44
Requests for Demobilization	19/45
Practitioners - Private - Mileage allowance	5/45

† Denotes C.C.N.O.

Subject	C.N.O. or C.C.N.O. No.
M - contd.	
Medical - contd.	
Staff - Repatriation Commission	579/45
Status of Personnel recommended to be invalided - Introduction of Form A.M.301Z	547/44
Store(s) Account for Scale "C" Medical Stores - Form 177G - Scale Base Depot Sick Bays Amendments No.1 and No.2	222/44
"C" Amendments No.1 and No.2	400/44
"E" and Coxwains set of First Aid Instruc- tions - Booklet - 1944	401/44
Service Afloat - Amendments Nos. 1 and 2	581/44
"Sick Quarter" Amendments Nos. 1 and 2	398/44
Members of the W.R.A.N.S. discharged on account of pregnancy	401/44
Memorandum - Official - Prices of clothing, etc. maintained for issue on repayment to ship's companies	†118/44
Memorial Prizes and Testimonials	51/44
Mental Disorder - Certification of members of R.A.N. suffering from Hospitals or Receiving Houses - Admission of Naval personnel	25/44
Mercurous Grease - Not to be used with Brasses and Bronzes	346/44
Mess Balances in H.M.A. Ships and Shore Establishments - Waivure.. .. .	160/44
Gear and Blankets - Issue to personnel travelling	161/45
Traps - Officers' - Replacement allowances - applicable for 1944-45	578/45
Utensils for Chief Petty Officers', Petty Officers' and Men's Messes - replacement allowances - Applicable for 1944-45	234/45
Messages of Congratulation	657/44
Messing - General - in small ships - installation	665/44
- Supply of Stainless Steel Trays	412,458/45
Microphotographic X-ray Examinations	626/44;348/45
Mileage Allowance - Private Medical Practitioners	175/45
Military Detention Barracks - Uniform and Clothing for Ratings	329/44
Milk Fresh and Milk Products - Restricted Issues	5/45
Mine(s) Rendered Safe - Disposal	356/44
Rendering Safe - Employment of personnel other than Officers	305/45
Washed Ashore - Rendering of Reports	252/44
Minesweeping - A.M.S. Vessels - alteration and addition - Spur for additional Signal Halliards	251/44
- Use of Iron Sinkers	45/44
Mining Stores - Shipment - Case markings	†118/44
Minol filled depth charges Mk.VII - VII*	†270/44
Minor War Vessels - Stowage for firefighting and action repair materials	59/45
Taken up for War Service	106/44
Misappropriation of Government Stores - Reports to civil police	†179/44
M.Ls. - Repositioning of depth charge chutes	485/44
Modification(s) for Listening Watch - Radar Type A.286 P/Q	72/44
- Guns Machine Bren .303" - Boxes Magazine Mk.I	†152/44
- Procedure for Accounting for Naval Stores in- corporated in W/T, A/S Radar, etc. sets	†113/44
- R.A.N. pattern haw screens	568/44
to Aerial Training System A/SI and A/S3 - Radar Types A.272, A.286 P/Q	139/44
Bridge Chart Table - Escort Vessels fitted with Radar	134/44
	†81/44
	†134/44

† Denotes C.C.N.O.

Subject	C.N.O. or C.C.N.O. No.
M - contd.	
Modification(s) - contd.	
to Catch Piece - Firing Gear - Gun Mounting 4" Mk.XXIII and XXIII*..	374/44
Evaporator Systems - H.M.A. Frigates ..	150/44
and A.M.S. Vessels..	†68/44
Firemain and Station 54 - A.M.S. Vessels	370/44
Magazines and Repair Magazine Main Springs - Guns Machine .303" Bren and .303" Vickers G.O.	394/44
o prevent wrong assembly - Guns Machine .303" in Vickers G.O.	395/44
- O.Q.F. 4.7" Mk.XII, XII* and XII B Breech Mechanisms ..	579/44
- Method of securing depth charge chute to deck Motor Launches	†26/44
- Steam Driven Boiler Room fans ..	195/44
- Type AT5/AR8 W/T - R/T set	80/44
Moluccas Area	†130/45
Monthly Ammunition Expenditure - Returns	224,†271/44
Morse Operators - Automatic - Visual Signallers, Coders and T/P - W.R.A.N.S. advancement	204/44
Mosquito Nets	215/44
Motor Alternators Patt. 5629A	148/45
Launches - Engine Register	162/44
- Fairmile - Type "B" - slipping ..	12/44
- Prevention of fire	124/44
- Replacements for Electrical Equipment ..	362/44
- Repositioning of D.C. Chutes	†184/44
- Telephones on Bridge	417/44
Transport - Economy in use	590/45
Forms	49/44
Vehicles - Naval - accidents	56/44
- Prevention of theft	574/45
- Rear Vision Mirrors	165/45
Mountings - 4" Mk.XXIII and XXIII* - Care in Assembly of Roller Units	610/44
Movements of personnel - reporting	256/45
Mulcts - Offences of Breaking Out of Ship	357/45
Musical Instruments - Bugles	509/44

N

Names - Allocation to Air Sea Rescue Vessels ..	412/44
Name ships - H.M.A. Shore Establishments ..	390/44
Naming of A/S. and Radar Maintenance Vessels ..	†198/44
Special Craft for S.R.D. ..	†250/44
75 ft. Loop Repair Vessels ..	†197/44
National Security Regulations - Delegation of Powers and Orders made thereunder	..179,390,417/45
Immobilization of Vessels Order (No.3)	483/44

† Denotes C.C.N.O.

Subject	C.N.O. or C.C.N.O. No.
N - contd.	
National Security Regulations - contd.	
Navigation and Anchor Lights Order (No.3)	343/44
(No.4)	423/44
Revocations ..	512,555/45
Naval Armament and Torpedo Store Account - Errors and Omissions	612/44
Depot, Darwin	†135/45
Store Accounts - H.M.A. Ships, etc. - Consumable Stores	383/44
- in D.E.M.S. - Accounting procedure	315,613/44
Base, Darwin - Organization	235/45
Board of Administration	541/44, 293/45
- Business Member	105/44
Canteens and Messes - Chocolates and Confectionery	138/44
Censorship	23,98,177,651/44; 215,242,378/45
Liaison Officer, Whyalla - Termination of Appointment	513/45
Medical History of the War	73/44
Military and Air Force Club, Adelaide	178/45
Officer(s)-in-Charge - Appointment - Rabaul	456/45
- Brisbane - Correspondence on Naval Armament Store Matters	174/45
- Flinders Naval Depot - Change of Title	567/45
- Termination of Appointment - Albany.. Broome.. Geraldton	447/45 581/45 295/45
- Transfer of Headquarters - New Guinea	424/45
Ordinance Inspecting Officers - Appointments to Darwin and Brisbane	†152/45
Personnel - Admission to mental hospitals or receiving houses	160/44
- Applications for discharge	205/44
- Delayed in transit and/or awaiting onward passage by rail on completion of leave	112/45
- Food coupons	266/44
- Repatriated - liability for further active service	206/44
Reserve Officers - Confidential reports	257/44
- Naval Watchkeeping Certificates..	256,519/44;2/45
- Promotion and confirmation	301/44
- Qualified status for officers of Commander's rank	111/45
Storekeeping arrangements and accounts - Responsibility for Inspection	99/45
Stores - Accounting for in Coastal Craft	561/45
Procedure in Frigates ..	244/44
- Consumable - Ledger Sheets - Amendment of Form A.S.151	246/44
Depot, Melbourne - Correspondence	35/45
in Stations and/or Services attached to H.M.A. Depots and Bases ..	515/45
Issuing Ship - Supply of Naval Stores for Escort Vessels in Northern Areas	287/45
Lost by accident, neglect or theft - Procedure	402/44
- R.A.N. Establishments	625/44
Returned to Bases from H.M.A. Ships and Services - Disposal ..	186/45
- Shipments Overseas and Consignments by Air and Rail in Victoria	559/45
Navigation Courses	59/44

† Denotes C.C.N.O.

Subject

C.N.O. or
C.C.N.O. No.

N - contd.

Navigation Courses to qualify for command of an A.M.S. -	
R.A.N.V.R. Officers	228/44
Navy, Army, Air Force Club of Victoria - Honorary Membership	609/44
Netherlands - Expenditure on behalf of - Classification	187/44
Forces - Members of, treated in R.A.N. Hospitals or sick quarters	205/45
Nets, mosquito	212/44
New Guinea - Period of Shore Service	105/45
Next-of-Kin particulars - Insertion in September Quarter Ledger	476/44
Night vision - Classification by A.R.L. Adaptometer (Mark III)	345/44
Non-substantive rates - Recommendation	367/44, 248/45
Northern Bases - Ammunition supply	†145/44
- Personnel serving at	150/44
Operational Bases - Stores consigned by sea or air freight	167/44
Notebooks containing Secret or Confidential Matter - Disposal	†176/45
Nursing Service - R.A.N. - Administration	47/45
- Supply of Nurses' indoor made-to-measure dresses	255/45

0

Oerlikon Guns and Mountings	595/44
- Housing - fitted with Mk.XIV Gyro Sights	254/44
Machine Guns - 20 m.m. - Spring Barrel Mk.II	585/44
20 m.m. Guns - Adaptor for American Rods - Cleaning and Ejecting - Introduction	505/44
H.E. Lot H.N.C. 13 - Withdrawal	309/44
N.F.E.404 - Ammunition - Withdrawal	310/44
T.P.C.746 - Ammunition - Withdrawal	487/44
Tracer Lot N.F.H.2257F - Ammunition - Withdrawal	307/44
10B/45 - Ammunition - Withdrawal	308/44
- Locking of barrels	349,465/44
- Mk.II and Mk.IV - Collapse of Barrel Springs Mk.I	350/44
- Mk.IIIA - Replacement by Mk.VIIA - A.M.S. Vessels	227/45
- One Man Cooking Device	261,586/44
- Spares, Appurtenances, etc. - Basic Sets	530/44
Offences committed by ratings on passage to and before joining H.M.A.S. "Melville"	83/44
Office Machinery - Annual Census	22/44
Machines - Method of Packing	168/44
Officers - Additional - borne for training in H.M.A. Ships	92/45
- Cap Badges	257/45
- Carrying out duties of gunners - Working suits	484/44
- Confidential reports	427/44
Dress	†30/44
- Executive - Radar Courses	†115/44
- Introduction of G.C.O.* and Gunner Substitute	†83/45

† Denotes C.C.N.O.

Subject

C.N.O. or
C.C.N.O. No.

O - contd.

Officers - contd.	
- Khaki Drill Service Dress	263/45
- Naval Reserve - Confidential reports	257/44
- Naval Watchkeeping Certificates	256,519/44
- Prisoners of War - Promotion	426/44
Promoted direct from warrant rank	11/45
- Transfer - in charge of Naval Stores on Permanent Loan	54/45
- Working Dress	316,442,581/45
Official Memorandum - Prices of clothing, etc. maintained for issue on repayment to Ships' Companies - Amendment	31/44
Oil Fuel	†96/45
- Naval Stocks in Australia	†15/44
- Lubricating - H.M.A. Ships "Kybra", "Wilcannia" and "Reserve"	109/44
Oiling at Sea - Special arrangements for H.M.A. Frigates - A.F.O. 4159/44	†59/45
Oilskin Anti-Gas Clothing - Upkeep and Repair	21/44
Clothing and Rubber Sea Boots - Storage	245/44
Ointment and Anti-Gas Eye Shields - Revision of Allowances	209/44
Operators - Teleprinter	62,271/44
Optical Instruments - Service and Lookout - Handbook on - B.R.797 - "1945" - Amendments	340/44
O.Q.F. 4-inch Mark XVI* Gun - Extractors	†11/44
40 m.m. Bofors - Locking of Screws, Securing Bracket Supporting Buffer - Fitting of Shock-proof washers	466/44
- Mk.I of Australian Manufacture - Springs Striker Breech Block - Examination	567/44
- Mk.I* - Springs Striker Inner and Outer	222/45
- Series Inspection	67/45
- Single Mountings - Fitting of Standard Grid Sights	550/45
Orchestral Bank Instruments - Percentage charge and grants-in-aid	197/44
Orders under National Security Regulations - Immobilization of Vessels Order (No.3)	483/44
Navigation and Anchor Lights Order (No.3)	343/44
(No.4)	423/44
Revocations	512,555/45
Wireless Stations Control Order - Revocation of certain directions thereunder	80/44
Ordnance and Electrical Mechanics	631/44
Branches	82/44
B.L. - Care of Obturator Seatings and Pads	685/44
Q.F. 40 m.m. Bofors - E.F.C. Valves	578/44
- Liquid in Recoil Buffers	311/45
- Mark I and I* - Modification to Breech Casing	588/45
- 2 pdr. Mark VIII - Adjustment to Cartridge Headspace	587/45
Oscillator Unit - Local - Radar Set A272 Mark I	†79/44
Outfit Gratuities for Officers of the Naval Reserve Forces on change of class of uniform	566/45
payable on promotion from commissioned Warrant Officer or Warrant Officer - Lieutenant (Emergency or Retired List)	211/44
Oxy-Acetylene Welding and Cutting Equipment	436/44

† Denotes C.C.N.O.

Subject

P

	C.N.O. or C.C.N.O. No.
P.A.C. and Snowflake Rockets - Precautions when carrying out practices or demonstrations	52/44
Projectors - A.M.S. vessels	†151/44
Rocket failures	6/44
Rockets - A.M.S. Vessels	88/44
Packages containing Asdic Stores - marking	†98/44
Packing and Transport of Enemy War Material and Explosives Stores of office machines - method	†15/45
Rings - Boiler Water Gauge Glass - Pattern 40	168/44
Paint Dry Colour - Issue of shading paste in lieu	21/45
- Types to be used for interior painting - Reduction of fire and smoke risks in H.M.A. Ships	44/45
Painting D.E.M.S. Gunnery Equipment	569/44
of Haversacks - Anti-Gas Respirators	350/44
Palmer LLH Petrol Engines - Operating Speeds	582/44
Passages to Australia for dependants of members of the Forces who have married abroad	269/45
Passports for wives and fiancées - Service personnel overseas	392,576/44
Pattern 474 Stretcher Cots - Supply	157/44
1937 - Web Equipment	245/44
Pay Accounts and Service Certificates of H.M.A. Ships attached to Eastern Fleet	137/44
Ship's Ledger	57,440/44
Arrangements - Liaison between Naval and Air Force Officers	467/44
- Deferred - Mobilized personnel	141/44
- Special rate for Warrant Officers	27/44
Paying off A.M.S. Vessels into Reserve at extended notice	361/44
H.M.A. Ships - Disposal of Relics, Trophies, etc.	†172/45
- Medical and Dental Stores	596/45
- Naval Armament Gunmounting Stores, etc.	509/45
Store Accounts	443,529/45
Stores	460/45
- Printed Matter, Books, etc. - Disposal	413/45
- Service System Canteens - Rendition of Report	571/45
Tenders - Procedure for dealing with Victualling Stores	572/45
Paymaster Lieutenant-Commander - Examination for rank of	485/45
Payment of Contractors' claims in connection with funerals	202/44
Fares of relatives attending funerals of deceased service personnel	250/44
Pendants - Distinguishing - Frigates and A.M.S. Vessels	274/44
Penicillin	575/45
- Care and custody	355/44
- Casualty Label Army Form A.A.F. D.115	497/44
Percussion Detonators - Watertight, Mark VII Lot 141, B.R.8/41 - Withdrawal from service	87/45
Personnel at sea - Emergency ration - supply of water bottles	41/44
- Awards and Honours to Naval	156/44
- Deceased - Cremation	300,288/44
- Letters found amongst effects	325/44
- Storage of effects	36/44
- Despatch of to ships and establishments in the New Guinea Area	640/44
Sydney for medical observation	450/44
- Discharged - Rehabilitation Procedure	258/44
- Distribution of - Maintenance Bases on Shore and Repair Ships	14/44
- Drafting - Malaria control	542/44
	118/44

† Denotes C.C.N.O.

Subject

P - contd.

C.N.O. or
C.C.N.O. No.

Personnel - contd.

- Employment of, other than officers - rendering mines safe	251/44
for Discharge - Application	205/44
in forward Island Areas - special clothing issue	224,282/44;89/45
- Movements - Reporting	236/45
- Naval - Food Coupons	266/44
- Liability for further active service	206/44
- Release	608/44
on leave at Sydney - Hospitality for - Command Amenities Liaison Officer	177/45
- R.A.N. - Remittances	122/45
- Record - Half-yearly reports on A/S equipment	†148/44
- Release - for the dairying industry	304/44
- Relief and Leave - Northern Areas	218/45
- R.M.S. for Service Afloat	158/44
Serving at Northern Bases	321/44
- Training - Asdic Installations Type 144/5	†70/44
travelling by troop train - Meals	568/44;119/45
- Issue of Mess Gear and Blankets	254/45
to and from Darwin by the Overland route - Issue of gear	37/44
Petty Officers - R.A.N.R. - Advancement to Chief Petty Officer	290/44
Photographic material for use in H.M.A. Ships and Establishments.. .. .	8/44
Pillow Slips and Sheets - Conservation	215/44
Pilotage - Claims	3,449/45
Pistols - Depth Charge - Mark VII - Restrictions on Issue	415/44
- Issue to D.E.M.S., etc.	†194/44
- M.L. 9.5-in. Depth Charge Thrower Mk.II - Use of Correct description	552/44
- Revolver - Losses	18/44
- Method of Consignment	357/44
- Puff Shots	519/44
Pitting in Engine Room Bilges - A.M.S. Vessels	†69/44
Plague	†207/44
Plugs for Exhaust Pipes - 63 ft. Air Sea Rescue Boats	†122/45
Wood Primer Tube - Depth charges	69/45
P.M.G. Certificates - Eligibility of telegraphist ratings for exemption in certain subjects of the examination for	75/44
Polarized Sun-Glasses - Replacement by Pattern 4074 Anti-Glare Spectacles	125,281/44
Police - Civil - Reports - Misappropriation of Government Stores.. .. .	72/44
Force - Engagement of Service personnel	644/44
Port Adelaide - Refit of A.M.S. vessels at - Replenishment of Naval Stores	34/44
Port Directors	556/45
- Reduction of Port Moresby	191/45
Postal Addresses - New Guinea Area	297,584/45
Postmen and Orderlies - Correspondence	259/44
Post War Employment - Disclosure of Top Secret, etc., Information to Civilian Firms	181/45
Practice Expenditure - Depth Charges	†122/44
Preamplifier - Pattern No. (Aust) 420 for Radar Type A. 286Q	†17/45
Precautions to be taken when returning C.S.A.M. drums	61/45
when carrying out practices - demonstrations with P.A.C. and Snowflake Rockets	52/44
Precedence, Rank and Command - R.A.N.R. and R.A.N.V.R.	226/45

† Denotes C.C.N.O.

Subject

P - contd.

	C.N.O. or C.C.N.O. No.
Preservation of Health - General Hygiene and Sanitation - including the prevention of malaria	269/44
Shells B.L. or Q.F.	68/45
Press - Communications with	153/44
Prices of Clothing, etc., maintained for issue on repayment to Ships' Companies - Amendments of Official Memorandum	51/44
Primers Depty Charge, Mks. VII and VIII and Type "M"	654/44
No.9 Mk.I A.N. - Required for test by I. N.O. Melbourne	149/45
Printed Forms	513/44
Prisoners of War and Personnel interned in Neutral countries - Pay and Allowances	469/44
- Officers - Promotion	426/44
- Ratings - Advancement - A.F.O. 106/45	282/45
- Repatriated - Medical Histories	510/45
Professional Examination(s) - Advancement to Petty Officer and Leading Seaman	241/45
- Warrant Electrician, R.A.N.	500/44
Engineers and Warrant Mechanicians	334/44
Writer and Warrant Supply Officer	333/44
Promotion and Confirmation of Naval Reserve Officers	301/44
of Naval Reserve Ratings to Warrant Rank	499/44
to temporary Warrant Rank	119/44
Warrant Writer and Warrant Supply Officer - Conditions	289/44
Propellant - Flashless	†142/45
Propeller Shafts - A.M.S. Vessels	†62/44
- Repair by Welding	268/45
Propellers and Tailshafts - Base Spares	371/44
Prophylactic Centres - control of venereal disease	†132/44
Prophylaxis - Tetanus	87/44
Protective Clothing	251/44;136/45
Provisions - Accounts - Necessity for prompt payment	217/44
- Canned - Warranty period	68,255/44
- Condemnation in Ships and Naval Establishments	317/45
- Fresh - Contract rates at Melbourne	101/44
- Orders	465/45
or other Victualling Stores - Report or Survey - Form A.S.330 - Rendition	36,349/45
Supplied to tenders when absent from parent ship - Accounts	385/44
- Supply to H.M.A. Ships from U.S. Navy Supply Ships and Depots	135/45
Publicity - Assistance for War Correspondents	338/45
Pumps - Reciprocating - Shuttle Valves - Heat Treatment	107/44
Punishment Summary - Stoppage of Leave whilst undergoing	251/45
Purchase of Naval Stores - Introduction of Form A.S. 133Z in R.A.N. Shore Establishments and Base Depots	419/44
Pusher Hoists 8-in. - Axis Pin of Tumbler Lever operating Pawl Housing Gear	94/45
Pyrotechnics and Rockets, Signal - Ammunition, Star Shell - All Calibres - Minimum range at which satisfactory functioning can be expended	195/44

† Denotes C.C.N.O.

Subject

Q

C.N.O. or
C.C.N.O. No.

Qualifications - Advancement to Chief Shipwright.	522/44
Qualified Officer "Status" - Full and modified grant	74,152/44
Ordnance (Optical) - Q.O. (O) - Non-substantive rate	497/45
Quarantine Control - Animals and articles subject to	498/45
Quarter Bills - Amendments	189/44
Quarterly return of temperature of storage of Cordite - Forms S.1147a - non-rendering	†100/44
Q.F. Gun Drill - Care in loading to avoid Damage to Fuzes	461/45
40 m.m. Bofors - Liquid in Recoil Buffers	375/44
2 pdr. Mk.IV Guns and 40 m.m. Rolls Royce Mountings - Disposal	20/45
Q.R. Is (S.U.) - Acting	478/45

R

Radar Admiralty Type - Components	†282/44
Warning and gunnery control sets - Maintenance	†294/44
Aerial Type B.A.P./H/M - Maintenance	†206,†211/44
Reconditioning and Modifications	†125/45
YFP - Modifications	†168/44
Australian Type - Authorized allowances of accessories (Test Equipment)	140/44
Beacons	†240/44;462/45
Carbon Pile Regulators Patt.W.1698 and W.2194 - Ventilation	479/45
Components and Spares	408/45
Control and Radar Plot Ratings Detailed arrangements - Reports	545/44
- Promotion to Warrant Rank	522/45
- Scheme - Policy	155,197,410,441/45
Courses for Executive Officers	†115,†296/44
Equipment - Allocation	†177/45
- Spares for U.S.N. Type	†55/44
- Wave Guide Fittings	†116,†163/45
Escort Vessels fitted with - Modification to Bridge Chart Table	†154/44;†51/45
Gyro Compass Repeats	†41/45
in A.M.S. Vessels	†9/44
Maintenance vessels and A/S - Naming	†198/44
Observation of fall of shot - communications - Anti-Ship Fire Control	†259/44
Offices - Nomenclature	†225/44
Outfits J.E. - P.P.I. Ventilation	170/45
Plot Branch - Opportunities for attaining Warrant Rank	569/45
R.A.N. Type - Authorized allowances of Test Equipment	†178/45
Reflector - Euston Reef Beacon	†119/44
Security	†46/45
Set A.272 Mark I Local Oscillator Unit	†78/44
Stores for H.M.A. Ships	151/45
Supply, Custody and Accounting	143/45
Test equipment of Australian manufacture	†241/44
Training Establishment	58/45
Transponder, instructions for fitting at R.A.N. Bases - Type 253	†107,†245/44

† Denotes C.C.N.O.

Subject

R - contd.

Radar - contd.		
Type A.79 - Withdrawal	†24/45	
Type(s) 253	†96/44	
(I.F.F.) Detonators	†174/45	
253/P, ABK - Suppression when fitted with A.286Q ..	†52/45	
253/P - Fitting and conversion of Type 253 to 253P ..	†55/45	
271/3, A.272, Flywood Lanterns - Maintenance ..	†38/44	
A.272 Mark I, Improved Valve Type NTA 98	†34/44	
Obsolescence of Aerial, transmitter - modulator and aerial control units	†87/44	
Modification to Overtravel switch of Aerial System CPT/M	†210/44	
Transmitter fitting of new matching transformer Type V.50744	†195/44	
A286 P/Q - Modification to Aerial Training System A/S 1 and A/S 3	†81/44	
Local Oscillator Unit - Modification ..	329/45	
Modification of Receiver Patt (Aust) 240 ..	†162/45	
Replacement of R.14 in Indicator Timebase ..	†165/45	
A.276 - Fitting	†82,†171/45	
282M(3)/M(4)/P/P(1)/P(2), 283, 284M(3)/M(4)/P(3)/- P(4), 285M(3)/M(4)/P(3)/P(4) - Switch Rotary Capacity, Design "E", Pattern - W.5896A Improved Geneva Cross Mechanism	†292/44	
- W.5896B - Maintenance	†293/44	
285P(3)/P(4)/Q - Provision of spotting tube ..	†90/45	
A.286 P/Q - Interference with W/T and R/T Reception - Modification for Listening Watch	†48/44	
A.286 Q	†113/44	
- Fitting of magnetic screens to 1802 Cathode Ray Tubes	†88/44	
- Preamplifier - Pattern No.(Aust) 420 ..	†37/45	
- 941/243Q - Introduction	†17/45	
Modification to Oil Seal of BAP/H/M Aerial ..	†100/45	
Walter Transmitter in Aircraft Emergency Dinghies ..	†219/44	
W/T, A/S etc. Equipment Establishment List ..	†170/45	
Radio Mechanic Branch - Advancement to Petty Officer Radio Mechanic(s)	311/44	
Messing in small ships	156/45	
Training and Advancement	501/44	
(R)(W) and (s) - Tool Kits	500/45	
Rafts - Lifesaving - Release	23/44	
Rail Accommodation - Adelaide to Melbourne	468/44	
Railway Fares - Concession - Service personnel travelling in Uniform and paying their own fares	97/44	
R.A.N. Armament Depot Darwin - Explosive and Gunwharf Stores ..	548/44	
Beach Unit	548/45	
Destroyers - Accounts	237/44	
Education Service - Reconstruction Training Scheme ..	602/45	
Establishments of Naval Stores	155/44	
Higher Educational Test - Results - 1943	156, 248/44	
- April 1944	439/44	
Nursing Service - Administration	47/45	
- Supply of Nurses' Indoor Dresses	255/45	
Pattern Haze Screens - Modification	154/44	

† Denotes C.C.N.O.

Subject

R - contd.

Range and Deflection Calculators - "Home Made"	472/44
Transmitter from Radar to Transmitting Station	546/44
R.A.N.R. and R.A.N.V.R. - Precedence Rank and Command	226/45
- Officers - Watchkeeping Certificate	256, 319/44
Officers - Confidential Reports upon	257/44
- Navigational course to qualify for command of an A.M.S.	228/44
- Watchkeeping Certificate	256, 319/44
Petty Officers - Advancement to Chief Petty Officer ..	290/44
Rates of treatment in approved private hospitals	203/45
Ratings - Accountant Branch - Temporary commissions ..	366/44
- Advancement - Notation of Seagoing Recommendations on Conduct Sheets and Notations in A.S. 264 Training in combined operations	465/45
- Claim forms for compensation for total loss of uniform - Forms A.S.103y and A.S.103z	221, 292/44
- Coder - Temporary Commissions	242/44
- Controlled and Observation Mining - Badges	414/44
- Convoy Signal	7/44
- D.E.M.S. Gunnery - Badges	104/45
- Engine Room - Examination - Results - September 1943 ..	93/44
- March 1944	13, 191/44
in Military Detention Barracks - Uniform and Clothing ..	344/44
Kits, drafted to Darwin, Thursday Island and New Guinea Areas	356/44
- Free - Issue on Entry	263/44
- Offences committed by - on passage to and before joining H.M.A.S. "Melville"	154/44
- R.N., on loan to the R.A.N. - Disposal of Service Certificates on reversion	83/44
- Selection for Drivers	190/44
Serving in Services Reconnaissance Department, Far Eastern Liaison Office and Allied Intelligence Bureau - Advancement	149/44
- Stores - (A.S.)	607/44
- Submarine Detector - Selection and Aural Care	167/45
- Supply	391/44
- Telegraphist	17, 172/44
Trained in combined operations - Advancement	75/44
Rationing - Clothes	279/45
- Bed linen	630/44
- Food and food economy	183/44
Rations - Action	265/44
- Emergency - for aircraft operating from H.M.A. Ships ..	645/44
Razor Blades - Safety - Gratuitous issues	67, 445/44
R.C.M. - Fitting of Equipment in H.M.A. Ships	496/44
Ready Use Lockers Patt.7152 - Modification for Stowage of Bofors Ammunition	†106/45
Re-arming with 4" XIX Guns on H.M.L.A. XXIII* Mounting - H.M.A. Ships	580/45
Rear Vision Mirrors - Motor Vehicles	260/44
Reciprocating Main Engines - Frigates	165/45
Recoil Buffers - Liquid - Q.F. 40 m.m. Bofors	†53/44
Cylinder Liquid - Gun Mountings - Test	375/44
Pumps - Shuttle Valves - Heat Treatment	192/44
Recommendations for non-substantive rates	107/44
Reconditioned Q.P. 2-pdr. H.E. H.V. ammunition	367/44
Reconstruction Training Scheme - R.A.N. Education Service ..	†143/44
	602/45

† Denotes C.C.N.O.

Subject
R - contd.

	C.N.O. or C.C.N.O. No.
Record of Naval Store Ledger-Keepers - Introduction of Form A.S.155x	298/44
A.S.155x	298/44
Records - Cordite - Maintenance on board H.M.A. Ships	89/44
Red Cross Society - Australian	544/44
Reduction of kits in H.M.A. Ships and Shore Establishments	241/44
Re-entry of W.R.A.N.S. ratings	125/45
Reeving of Beckets - Clips Cartridge No.25	164/44
Refresher escort training organisation	755/44
Refrigerating plant for cold room - A.M.S. vessels	210/44
Refrigerator and Air Conditioning Equipment in H.M.A. Ships -	
Maintenance	450/45
- Domestic automatic - Test lamp for	488/44;72/45
- Maintenance in H.M.A. Ships and Establishments by	
the R.A.A.F.	128/45
Registration - Confidential correspondence	500/44
Rehabilitation procedure for discharged personnel	14/44
Relatives attending funerals of deceased service personnel -	
payment of fares	274/44
of Naval personnel - Investigating concerning welfare	669/44
Release for University study	15/45
of personnel for the dairying industry	304/44
Relics and articles of historical value	7221/44
Presentations and Trophies held in H.M.A. Ships, etc.,	
Paying off - Disposal	596/45
Remittances by R.A.N. personnel	122/45
Re-naming - H.M.A.S. "Vigilant"	285/44
- H.M.A.S. "Viking"	286/44
Rendering Mines Safe - Employment of personnel other than officers	
of Forms S.1148(h), (i) and (j) - Failures of Armament	
Material and Ammunition	294/44
Repainting of A.M.S. vessels	110/44
Repatriated Naval Personnel - Liability for further active service	
206/44	
Repatriation Medical Institutions - Staff	528/45
Out-patient Clinic, St.Kilda Road, Melbourne	447/44
Repayment Clothing in Tenders	163/45
Issues of Materials - Uniform and clothing supplies	171/44
Replacements for electrical equipment in M.Ls.	362/44
Replenishment of Naval Stores by A.M.S. vessels refitting at	
Port Adelaide	34/44
Reports - Ammunition - 20 m.m., 40 m.m., 2-pdr. - 20 m.m.	
Oerikon H.E. - Withdrawal of certain lots	142/44
- Confidential, on Naval Reserve Officers	257,427/44
- Firefighting Equipment Trials	161/44
School	138/45
- Half-yearly on Asdic Equipment - Record of personnel	
of Proceedings	7148/44
- Coastal craft	592/45
- H.M.A. Ships	719/45
Seasickness - Form A.M.1142	797/45
Stock and Transactions - Guns and Gunmountings	449/44
Stocktaking - Form A.S.148	443/44
Survey on provisions or other Victualling Stores -	
Form A.S.350	258/45
- Rendering - Mines washed ashore	56/45
- Stocks of Ammunition	45/44
- Weekly stock - Depth charges and associated stores	166/44
Resistances - Charging - D/F and W/T	747,764,772,7135/44
Respirators - Anti-gas - Care	751/45
- Light Type	79/45
- Painting of Haversacks	596/44
	382/44

† Denotes C.C.N.O.

Subject
R - contd.

	C.N.O. or C.C.N.O. No.
Results - Education Test I - September, 1945	81/44
- December, 1945	205/44
- March, 1944	318/44
- June, 1944	473/44
- September, 1944	668/44
- December, 1944	147/45
- March, 1945	300/45
- June, 1945	437/45
- Examination - Engine Room Ratings - September, 1945	
- March, 1944	15,191/44
- September, 1944	344/44
- March, 1945	103/45
- Sick Berth Staff - November, 1945	299,354/45
- May, 1944	104/44
- November, 1944	438/44
- May, 1945	78/45
- Higher Educational Test - October, 1945	377/45
- April, 1944	156/44
- October, 1944	459/44
Return of empty gas cylinders	25/45
Revocation of certain orders under the Wireless Stations Con-	
trol Order	48/44
Revolver, Ball Cartridge S.A. .455" - Mark II - Withdrawal	80/44
Pistols - Issues to D.E.M.S., etc	188/45
- Losses	7194/44
- Method of consignment	18/44
Revolvers - Accidents	337/44
Ribbons - Medal - Wearing with tropical dress	86/44
- War Service	312/44
Rifles Aiming 1-in. Elswick "A" Supply for use in 4-in. Mark XIX	
Guns fitted in H.M.A. Ships	400/45
Breech Covers No.2	614/44;106/45
Inspection	208/45
Slings and universal sling hooks - Use	531/44
R.M.S. personnel for service afloat	62/45
R.N. Forces at Australian Ports - Supplies of Naval Stores	
Ratings on loan to the R.A.N. - Disposal of Service Certif-	
icates on reversion	158/44
Rockets - Illuminating - 3 3/4 lb.	262/45
- Failure	190/44
- Prematures	40,676/44
- P.A.C. - A.M.S. vessels	570/44
and Snowflake - Precautions when carrying out	
practices or demonstrations	40/44
- Failures	88/44
- Flare Projectors - Fitting - As and As	52/44
- Target practice Mark I ³ , Lots 129 and 144 - Withdrawal	
Reports	3/44
2" U.P. Failure	7164/45
Roller and ball bearings - Procurement	320/44
Royal Australian Naval Volunteer Reserve - Regs. and Instrns.	
for Women's Services - Uniform and clothing	
authorized kit	121/44
Nursing Service - Wearing of shoulder straps	4/44
Navy Personnel - Australian service hospitals	55,103,128/44
- Dental treatment	175/44
Ships - Paying off	157/45
Netherlands Navy in Australia - Telegrams	171/45
R/T Interference - A/S Equipment in M.Ls.	594/45
W/T Installation Type R.C.8 - Supply of Low Power	50/44
Rubber sea boots and oilskin clothing - storage	761/44
Rudders - Fairmile	730/45
	245/44
	293/44

† Denotes C.C.N.O.

Subject	C.N.O. or C.C.N.O. No.
S.A. Gear Type C Mks I and II	†151/45
Sales of Stores and Property	560/45
Saline (Salt) tablets	405/44
Salvage Money - Naval - Distribution	551/44
of condemned unserviceable, etc., stores - Army Salvage Service	267/44
Salvus self-contained breathing apparatus, pattern 3485	98/45
Sanitation and general hygiene - Preservation of health, includ- ing the prevention of malaria	269/44
Savealls under motor boat engines	503/44
Scientific section - Tropical	271/44
Scuttling charges - Fitting in Fairmiles, M.Ls. and H.D.M.Ls.	†250/44
Sea Boots and oilskin clothing - Rubber - Storage	245/44
- Leather - Economy	80/45
Searchers Steel Wire, Pattern 290	430/44
Seasickness - Report of - Form A.M.114Z	449/44
Tablets - Issue to Service Afloat	162/45
Seaward Defences - Addresses	595/45
Secret and confidential correspondence - Instructions re acknow- ledgment, Disposal, etc	†56/44
- Security	†99/44;†136/45
Matter - Disposal of Notebooks	†176/45
Confidential and O.U. Books - See Corrections, etc.	†205;411/44
Security Classifications	149/44
Selection of Ratings for Divers	647/44
Senior Naval Officers Beach Unit	513/44
Combined Operations Section	201/44
Service Afloat - Definition - 1959-45 Star - Persons eligible Certificates and Pay Accounts of H.M.A. Ships attached to Eastern Fleet	57,440/44
- On reversion - disposal - R.N. ratings on loan to the R.A.N.	190/44
Chevrans	475/44
Shading Paste - Issue in lieu of paint, dry colour	44/45
Shafting - Misalignment in M.Ls.	547/44
Shell(s) Grabs - 8" Screw Down Type	591/44
- B.L. or Q.F. - Preservation	68/45
Sheets and Pillow Slips - Conservation	215/44
Shipment of Mining Stores - Case Markings	59/45
Ships - Landing - Infantry - Administration	†117/44
- Ledger and Pay Accounts	467/44
Shoes - Galley, for Cooks - W.R.A.N.S.	77/44
- Gymnastic for W.R.A.N.S.	19/44
Introduction of Substitute Pattern	662/44
Shore Establishments and H.M.A. Ships - Reduction of kits H.M.A. - Name Ships	241/44
R.A.N. - Wartime allowances of bedding	270/44
Weekly Report of Stock by - Ammunition - Form A.O.52	469/44
Service at Darwin and Thursday Island - Period	326/44
New Guinea	680/44
Shoulder straps - Wearing	105/45
Shuttle valves of Reciprocating pumps - Heat treatment	175/44
Sick Berth Staff - Examination results - November, 1943	107/44
- May, 1944	104/44
- November, 1944	458/44
- May, 1945	78/45
Sights - Conversion of Mk.IV (100 knots) to Mk.V (100 knots) and fitting of Mk.III Butt Plate - Lewis Machine Guns .303-in.	377/45
Signal(s) and Cypher Logs - Disposal	552/44
	†44/44

† Denotes C.C.N.O.

Subject	C.N.O. or C.C.N.O. No.
S - contd.	
Signal(s) - contd.	
- Apparatus - Identification - Indicator Loop	†239/44
- Indications of Priority	505,591/45
- Ratings - Convoy	104/45
- Referring to Nursing Sisters	281/45
- Traffic	207/44;549/45
Sleeves and torches for inflatable lifebelts - Life Saving Equipment	212/44
Small Arms Ammunition - Allowances for shore bases	†66†101/45
- Life throwers, shoulder, coston - Replacement by Rifles M.L.E. line thrower	123/44
- Revolvers - Accidents	86/44
- Rifles and sub-machine guns - Allowances	†138,†262/44
- Tools - Plates, Screw and Taps, S.A.	455/44
Ships - Ammunition Outfit - Arrangements for periodical exchange, examination, etc.	525/44
Soda Ash - Use in lieu of soda crystals	113/44
South West Pacific Area	406/45
Southern Cross Club, New York	460/44
Spares - Base for propellers and tailshafts	371/44
- Depth charge thrower pistols	65/44
for U.S.N. Type Radar Equipment	†33/44
Special clothing for mosquito and sandfly infested areas - Issues for personnel in forward Island areas	224,282,494/44;89/45
Victualling assistance to seagoing ships victualled on the repayment system	444/44
Spectacles - Anti-glare - Pattern 4074 - Supply	30,125,281/44
Supply - General conditions	172/45
- in the New Guinea Area	250/45
Sperry Mark XIV Gyro compass - Condensers - Follow up circuit	379/44
- Repeater Bezel Screws	377/44
- Mod. I Gyro Compass - Incorrect fittings of transmitter connecting cables	514/44
- Mercury Ballistic Caps	378/44
- Oiling of upper vertical guide bearing	376/44
Springs - Barrel Mk.I - Collapse of - Oerlikon guns 29 m.m. Mks. II and IV	350/44
Spur for additional signal Halliards - A.M.S. fitted for mine- sweeping - Alteration and addition	†118/44
Stability - A.M.S. vessels	†177/44
Staff and Training Requirements Division, Navy Office	464/44
for Repatriation Medical Institutions	528/45
Star (1939-45) - Persons eligible, and definition of "Service Afloat"	201/44
- Shell allowance	†128/44
Pyrotechnics and rockets, signal - Ammunition - All calibres - Minimum range	193/44
Statements by Service Medical Officers regarding benefits after discharge	482/44
Stationery - Economy in use of	428/45
Statutory Rules governing the administration of Women's services - R.A.N.	646/44
Stawell Prize for 1945	251/45
Steam driven boiler room fan engine - Vibration - A.M.S. vessels	†123/44
Steel chests for A.M.S. vessels	181/44
Furniture - Supply to H.M.A. Ships	356,354/44
Stocktaking - Report - Form A.S.148	258/45

† Denotes C.C.N.O.

Subject
S - contd.

Stocks of Naval Oil Fuel in Australia	†15/44
Storage of Cordite - Quarterly return of temperatures - Non-rendering - Form S.1147a	†100/44
Explosives in buildings other than Magazines and Explosives Stores	569/44
Oilskin clothing and rubber sea boots	245/44
Storekeeping Ledgers - Naval - Re-arrangement	656/44
Store - Naval - Accounting Procedure - Frigates	244/44
Stores and Property - Sales	560/45
Supplies - Theft and misappropriation - precautions	118/45
- Canteen, for H.M.A. Ships	198/45
- Care of - When ships are undergoing repair, etc.	533/44
Condemned, unseviceable, etc. - Salvage - Army Salvage Service	267/44
- Consumable - Naval Armament Store Accounts - H.M.A. Ships, etc.	585/44
- Damage control Lockers	506/44
- Government - Misappropriation - Reports to Civil Police	72/44
- Medical and Dental - Supply in the New Guinea Area	212/45
- Form A.M. 177G Medical Store Accounts for Scale "C"	222/44
- Scale "E" and Coxswains Set of First Aid Instructions - Booklet - 1944	581/44
- Mining - Shipment - Case Markings	59/45
- Modification - A/S installations	†99/45
- Naval - Accounting for, Coastal Craft	561/45
Incorporated in W/T, A/S, Radar	424/45
etc, Sets	507/44
and Defect List Items - Return	507/44
Armament Gunmounting and Torpedo - Despatch to Melbourne	43/44
- Consignment by Rail	274/45
- In D.E.M.S. - Accounting Procedure	315/44
- Issued by U.S. authorities	224/45
Establishment	625/44
H.D.M.Ls - Establishment	304/45
Incorporated in W/T, A/S, Radar etc. sets - Modification of procedure for accounting	159/44
Lists of, on Permanent Loan etc. Forms 1099 and 1099B - Revision	359/45
Lost by accident, neglect or theft - Procedure	402/44;454/45
Marking of Ledger when when store charge certificate is given	308/45
On permanent loan - transfer	491/44
Prevention of Misappropriation, Losses, etc	481/45
Procedure for supply etc. in Radar and A/S Repair and Maintenance vessels	220/45
Purchases of - Introduction of Form A.S.133Z in R.A.N. Shore Establishments and Base Depots	419/44
Returned from H.M.A. Ships and Services - Disposal	186/45
Replenishment by A.M.S. vessels refitting at Port Adelaide	34/44
- H.M.A. Ships	315/45
Responsibility as to custody in small vessels	687/44
Supplies to R.N. Forces at Australian Ports	262/45
Vessels being paid off under the Demobilization Scheme	413/45
- Packages supplied with	453/45

† Denotes C.C.N.O.

Subject
S - contd.

Stores - contd.	
- Permanent Naval - Combustion cones for boilers	91/44
- Radar - Supply, custody and accounting	143/45
- Ratings (A.S.)	167/45
- Shipped, etc. from H.M.A. Naval Store Depots - Despatch of Advance Supply Notes	642/44
- Discrepancies	51/44
Transferred from the U.S. Navy to the R.A.N.	456/44
- Victualling - Demands	665/44
- Non-delivery, consigned to H.M.A. Ships or Establishments	404/44
Stoves - Kerosene, in small craft	173/45
Stowage for firefighting and action repair materials - Minor war vessels	†179/44
Stretcher cots - Pattern 474 - Supply	243,535/44;344/45
Submarine Detector Ratings - Selection and Aural care	391/44
Sugar - Consumption outside Territorial waters	337,553/44
Suitcases and small blue drill kit bags - Variations in kit	234/44
Suits - Brown dungaree combination - Loan issue to officers	112/44
Summary punishment - stoppage of leave whilst undergoing	251/45
Sun Glasses - Polarized - Replacement by Pattern 4074 anti-glare spectacles	125,281/44
Reflecting device for H.M.A. Ships	33/44
Supply Branch	587/44
of Anti-Glare Spectacles Pattern 4074	30/44
Canteen Stores	283/44
Cigarettes and Tobacco - Personnel on leave or discharge	82/45
Civilian clothing to members of the Naval Forces on Discharge,	214/44
Coal for H.M.A. Ships - Procedure	32/44
Low Power W/T - R/T Transceiver Installation - Type R.C.8	†12,†37/44
Officer, 7th Destroyer Flotilla	180/45
Rating (A.S.) - New rating	17/44
Ratings and Junior Writers - Typewriting Experience	172/44
Spectacles - Delegation of authority	297/44
- General conditions	172/45
Stores for Anti-Malarial Measures	15/44
Suppressive Treatment (Prophylaxis) for Malaria, with Atebrin	240/44
Survey on provisions and other Victualling Stores - Reports of Form A.S. 330	127,223/44
Sydney Command	320/45

T

Tablecloths and Mats	5,457/44
Tablets - Saline (salt)	403/44
Tails Propelling Rocket U.2" Mark II - Not to be used	42/44
Tailshafts and Propellers - Base Spares	371/44
Target Practice Mark I*, Rockets, Lot S.129 and 144 - Withdrawal - Reports	324/44

† Denotes C.C.N.O.

Subject

T - contd.

	C.N.O. or C.C.N.O. No.
Targets - Anti-Craft - Kites and Drogues - Discontinuance of Supply	146/44
Telegrams to Naval personnel	565/45
Telegraphist Ratings - Eligibility for exemption in subjects of the examinations for P.M.G. and Certificates	75/44
Telephones on Bridge - M.Ls.	417/44
Teleprinter Circuits - Transmission of Secret and Confidential Messages in P/L	†179/45
Operators	60,272/44
Telescopes Gun Sighting Potts G.A.100 and G.A.100	382/45
Temporary Commissions - Accountant Branch Ratings	368/44
- Coder Ratings	414/44
- Selection of Ratings from the Lower Deck	474/44
- Engineering Branch	219/45
- Special Branch R.A.N.V.R.	200/45
Warrant Rank - Promotion	119/44
Tenders - When absent from Parent Ship - Accounts for provisions supplied	385/44
Test Lamp for Domestic Automatic Refrigerators	488/44
of Recoil Cylinder Liquid - Gunmountings	192/44
Testimonials and Memorial Prizes	25/44
Testing Equipment - W/T - R/T Set - Modification	†80/44
Tetanus - Prophylaxis	87/44
Text Books - Vocational Training	287/44
Theft and Misappropriation of Stores - Precautions	118/45
Thrower Pistols - Depth Charge - Spares	65/44
Throwers - Depth Charge Mark II - Replacement	†25/44
Time Fuzes No.401 Marks I and IA	153/44
on Board H.M.A. Ships - Annual percentage landing in War time	253/44
Tins, Baking Bread	174/45
Tool Kits for Ordnance and Electrical Mechanios	439/45
Radio Mechanios (R) (W) and (S)	23/45
and (c)	395/45
Torpedo ratings and wiremen	582/44
Tools - Compensation for loss	184/44
- Machine - Co-ordinated use in Australia between the Services	611/44
Torches and Sleeves for Inflatable Lifebelts - Life Saving Equipment	212/44
Torpedo and anti submarine branches - Amalgamation	586/45
- Acoustic Homing - Counter measures - F.X.R. Gear	†120/44
- Depot, Darwin	†56/45
Fremantle	65/44
Pinkenba	356/45
- Igniters, Mark XI - Lot 144, Filled SWYN 9/41 - Withdrawal	64/44
- Lot No.217, Filled B.R.12/41 - Withdrawal	155/44
Total loss of Uniform and Clothing - Compensation - Ratings	147/44
Training classes at Balmoral Naval Depot	246/45
Films and Film strips held on board - Return	74/45
Transceiver Installation Type RC.8 - Provision - Additional Crystal	†281/44
Transfer of "Hostilities only" ratings to Permanent Naval Forces	353/45
Machinery and Plant	324/45
N.A.P. to R.A.N.V.R. - Certificates of Service	419/45
Naval Stores on permanent loan	491/44
Officers having charge of stores on permanent loan	54/45

† Denotes C.C.N.O.

Subject

T - contd.

	C.N.O. or C.C.N.O. No.
Transfer of - contd.	
"Q" class Destroyers to R.A.N. and reversion of "N" class Destroyers to R.N.	585/45
Transmission of confidential messages in plain language over Teleprinter channels	†153/44;†179/45
Transmitter-Receiver - Emergency - in Frigates	†58/45
Transponder - Radar - Type 253 - Instructions for fitting at R.A.N. Bases	†107/44
Transport of Coding Machines and Spare Parts	†24/44
Mails in H.M.A. Ships	525/44
Transportation - Service personnel travelling in uniform	37/44
Travel concessions in New South Wales for members of the Forces	335/44
Travelling and Freight Warrant Books - Disposal	659/44
by Troop Train - Meals for R.A.N. personnel	368/44
- Concession Railway fares of Service personnel in Uniform and paying their own fares	548/44
Warrants on discharge or demobilization	331/45
- Signatures of Issuing Officers - H.M.A. Ships	374/44
Treatment in approved private hospitals - Rates	305/44
of ex-members of the Forces suffering from malaria which did not manifest itself during the member's service	173/44
Serving members of the Forces at Repatriation Out-patient Clinic, St.Kilda Road, Melbourne	447/44
Trials - Gun - Procedure	38/44
Tropical Dress - Medal Ribbons	312/44
Outfit - Grant for	353/45
- Wearing ashore on the Mainland	564/44
Scientific Section	271/44
Trunk Line Calls by Naval Personnel	327/45
Tubes Friotion - Machine Rocket Signal Mk.IV - Withdrawal M.R. Signal - Failures	656/44
- Withdrawal of certain lots	117/45
Vent, Electric 1-in. I.C.I. manufacture	†153/44
Tunics, Drill, with Blue Facings - Shedding of Dye	71/44
Type AT5/AT8 W/T - R/T Set - Modification	†80/44
A272 Mk.I Radar - Obsolescence of Aerial, Transmitter - Modulator and Aerial Control Units	†87/44
255 - Radar Transponder, Instructions for fitting at R.A.N. Bases	†107/44
Tyres and tubes - conservation	232/45

U

Unfitness, Physical, for Service - Discharge from R.A.N. on account of	116/45
Uniform(s) and clothing and anti-gas respirators - Return of loan items on Final Discharge	144/45
- Authorized Kits - R.A.N. Women's Services	55/44;562/45
- W.R.A.N.S.	20,128/44;137/45

† Denotes C.C.N.O.

Subject C.N.O. or
C.C.N.O. No.

U - contd.

Uniform(s) and clothing - contd.		
for Ratings in Military Detention		
Barracks	556/44	
- Gratuitous Issues to British and Allied Services	661/44	
- Supplies - Repayment Issues of materials	493/44	
Officers' - Agreement for the supply of - Inclusion of Uniforms for Nurses and W.R.A.N.S. officers	215,499,577/45	
Outfit Gratuities on change of class	150/44	
Ratings and band ratings - Made-to-measure - Prices	452/45	
- Deviation from Standard Patterns	461/44	
- Made-to-Measure - Contracts for supply of	405,508/44;	
	121,467/45	
	350/45	
- Limitation of Purchases	363/44	
United Kingdom - India, Air Mail	115/45	
United States Naval Personnel in civil Gaols - Maintenance	15/45	
University Study - Release	78/44	
Unserviceable American Ammunition - Disposal		
Condemned, etc., Stores - Salvage - Army Salvage Service	267/44	
Flags and Inglefield Clips - Return to Store	69/44	
Upper Deck Fittings - H.M.A. Ships - Maintenance	178/44	
Use of Army Medical facilities in transfer of invalids	641/44	

V

Vacancies - Department of the Navy	276,360/45	
- Repatriation Department	422/45	
Vaccination and Re-vaccination	†248/44;88/45	
Valedictory - Vice Admiral A.S. Carpender, U.S.N.	24/44	
Valve(s) or W/T, Radar etc. services - Accounting	223/45	
- Improved Type N.T.A. 98 for Radar Type A272 Mark I	†34/44	
- Shuttle - Reciprocating Pumps - Heat Treatment	107/44	
Vanadium Bearing Petroleum Ashes - Collection from oil burning ships	521/44	
Variations in Kit - Small Blue Kit Bags and Suit Cases	234/44	
V.C. Recognition Challenge Procedure	†32/45	
Vehicles - Naval Motor - Accidents	56/44	
Veneral Disease - Control of - Prophylactic Centres	†117/45	
Ventilating Fan - Loss	66/44	
Ventilation - Additional - A.S. Directing Gear Compartment	†167/45	
of Asdic Bridge Hut - Types 127A/B/c and 128A/B/C	†115/45	
- H.M.A. Vessels	454/44	
- Wardroom Pantries - A.M.S. Vessels	†89/44	
to forward Magazine - A.M.S. Vessels	†114/45	
- 72 ft. H.D. M.Ls. ex U.S.A.	†79/45	
Vessels - A.M.S. - see A.M.S. vessels		
V.H/F Transceiver Type DR 106 - Installation in H.M.A. Ships	†45/45	
Vibration of steam-driven boiler room fan engine - A.M.S. vessels	†123/44	
Vickers Machine Guns .303" - On Single A.A. Mountings - Butts	39/44	

† Denotes C.C.N.O.

Subject C.N.O. or
C.C.N.O. No.

V - contd.

Victory Loan		45,588/45
Victualling arrangements - Christmas Day 1944		617/44
Assistance - Special - to Seagoing Ships victualled on the Repayment System		444/44
Store(s) - Consignments of to H.M.A. Ships and Establishments - Non delivery of		404/44
- Demands	663/44;107/45	
- Depot Darwin - Re-establishment	468/45	
- Issuing Ship "Mercur"	185/45	
- Procedure in tenders paying off	483/45	
Vision - Night - Classification by A.R.L. Adaptometer (Mk.III)	345/44	
Visual Signallers, Coders, T/P and Automatic Morse Operators - W.R.A.N.S. - Advancement	204,653/44	
Training Instructors	55/45	
Voice Pipe Communication - A.M.S. vessels - Alteration and Addition	†103/44	
V/S 1 and W/T 1 - Granting of Non-Substantive rates	420/44	

W

War correspondents - Publicity		184/45
Gratuity to members of the Naval Forces		525/45
Loans - Service allotments for continuous subscriptions		471/44
Service - Apprentices		291/44
- Chevrons		219/44
Wardroom Skylight - Fitting - "B" Type M.Ls.		†98/44
- 72 ft. H.D.M.Ls. ex-U.S.A.		†88/45
Warrant Engineer and Warrant Mechanician - Professional Examination		334/44;
		245/45
Officers - Special Rate of Pay		361/44
Rank - Temporary - Promotion		119/44
Writers and Warrant Supply Officers - Professional Examination	333/44;244/45	
- Promotion - Conditions		289/44
Warrants - Leave Travelling Concession - Issue		448/44
Warranty period for Provisions		68,235/44
Wartime allowances of Bedding - R.A.N. Shore Establishments		469/44
Washers - Compressed Asbestos Fibre		43/45
- India Rubber for hose couplings - Use of correct patterns		534/44
Watchkeeping Certificate - R.A.N.R. officers	256,319/44;2/45	
Watches lost by Personnel as a result of Service Casualty - Compensation		318/45
Water Bottles - Emergency water ration for personnel at Sea - Supply		136/44;6/45
Fresh - Supply to H.M.A. Ships		658/44
Pressure Test - Gas Cylinders	295/44;60/45	
Shore - Use, for Water Tube Boilers		†161/44
Watertight Percussion Detonators - Mark VII Lot 141 B.R.8/41 - Withdrawal from service		41/44
Wattle Rod Fenders		280/44

† Denotes C.C.N.O.

Subject

C.N.O. or
C.C.N.O. No.

W - contd.

Wearing of Shoulder Straps - Royal Australian Naval Nursing Service	175/44
Web Equipment - Pattern 1937	137/44
Weekly report of stock by Shore Establishments	326/44
Stock Reports - Depth charges and associated Stores	†72, †155/44
Weir Type Feed Pumps	504/44
Welding and Cutting Equipment - Oxy-acetylene	436/44
Safe Operating Procedure	596/44
Wharves - Enclosed - Entry	459/43
Wills - Compulsory making	220/44
Wireless Stations Control Order - Revocation of direction under	80/44
Wiremen - Ratings - Advancement	556/44
Wives and Fiances - Passports - Service personnel overseas	157/44
Women's Royal Australian Naval Services - Calculation of Time	597/44
- Convalescent Home	284/44
- Statutory Rules	646/44
- Uniform and Clothing - Authorized Kit	20,55,103,128/44; 562/45
Services - Extra Duty Allowance not payable	253/45
- Procedure when presented to their Royal Highnesses	249/45
- Special issue of Coupons for purchase of Nightwear	563/45
Wooden Furniture - Replacement by Steel, in Cruisers, Destroyers, A.M.S. Vessels, and "Warrego" and "Swan"	554/44; 332/45
Working Suits - Officers carrying out duties of Gunners	474/44
Wound stripes	183/45
- Distinction marks for wounded	48/45
Wounds and injuries by enemy action	550/44
W.R.A.N.S. - Advancement	259/45
to C.P.O. W.R.A.N.S.	576/45
- Bedding for	169,386/44
- Drafting	159/44
- Galley shoes for Cooks	77/44
- Gymnastic shoes	19/44
- Marks of Respect	323/45
- Medical attention	572/44
- Members discharged on account of Pregnancy	†116/44
- Professional examination for higher rating - Date of passing	247/45
- Ratings - Made-to-measure Jackets and Skirts - Contracts for supply	406,628/44; 120,466/45
- Re-entry	125/45
- Sick berth rating - Examination	250/45
- Uniform and Clothing	20,55,103, 128/44; 137/45
- Visual signallers, coders, T/P and automatic morse operators - Advancement	204/44
- W/T Ratings - Advancement	273/44
Writer Junior and Supply Ratings - Typewriting experience	172/44
W/T and D/F charging resistance	†31/45
- A/S, Radar etc, Equipment - Establishment List	311,502/44
Equipment - Requisitioned Vessels - Maintenance by A.W.A.	302/45
Ratings W.R.A.N.S. - Advancement	273/44
- R.T. Installation Type R.C.8 - Supply of Low Power	†30/45
Testing Equipment for Frigates	194/44
1 and V/S 1 - Granting of acting non-substantive rates	420/44

† Denotes C.C.N.O.

Subject

C.N.O. or
C.C.N.O. No.

X

X-ray Examinations - Microphotographic	329/44
Films - Shortage	152/45

Z

Zinc sheets and underwater protection of ships and fittings - H.M.A. Ships	517/44
--	--------

† Denotes C.C.N.O.

LIST OF NAVY ORDERS ISSUED BETWEEN 1st JANUARY, 1939 AND
26th JUNE, 1945, WHICH HAVE BEEN CANCELLED.

Cancelled Order	Superseded by	Cancelled Order	Superseded by
<u>1939</u>		<u>1941 - contd.</u>	
59	50/40	113	601/43
50	420/43	114	326/45
85	107/39	127	551/41
96	420/43	129	555/41
158	37/40	153	156/45
159	91/40	154	25/44
		155	595/42
		148	105/45
<u>1940</u>		154	259/41
2	249/40	155	566/41
54	532/42	157	234/42
57	152/41	164	380/45
41	38/41	183	354/42
43	521/44	193	527/45
50	305/44	206	156/45
89	542/42	216	351/45
90	155/40	222	580/44
91	25/41	228	105/45
104	282/42	255	612/44
116	612/44	255	542/45
120	39/41	261	354/42
146	285/40	263	212/42
150	593/42	319	342/42
167	61/44	326	429/45
178	145/45	340	410/42
188	250/40	344	465/45
215	578/45	350	527/45
216	504/42	368	459/45
228	489/45		410/42
252	528/45		
240	504/42	<u>1942</u>	
243	580/44	2	105/45
250	75/42	18	256/44
257	498/45	28	429/45
269	456/45	38	448/42
275	559/45	47	561/44
280	257/45	60	250/42
501	315/41	69	104/45
		75	446/45
		82	250/42
<u>1941</u>		86	250/42
4	64/41	89	446/45
9	562/45	104	559/45
10	513/45	105	609/44
22	601/45	107	250/42
25	252/45	119	265/44
58	504/45	127	526/45
42	555/41	133	342/42
54	252/41	140	612/44
74	305/44	147	518/45
85	545/44	158	446/45
105	412/42		

Cancelled Order	Superseded by	Cancelled Order	Superseded by
<u>1942 - contd.</u>		<u>1945 - contd.</u>	
160	552/42	†29	†57/45
170	552/45	†34	†56/44
177	448/42	†36	†85/44
183	519/45	40	519/45
184	414/45	41	229/44
205	305/44	45	257/45
219	154/45	†46	†72/44
230 - Part 2(b)		46	127/44
(111)	575/42	49	104/45
- Part 2(q)	210/45	†50	†164/44
239	359/45	56	580/44
248	265/45	†60	†63/45
250	480/45	†61	†117/44
281	55/45	†64	†158/45
282	149/45	†69	†177/44
285	146/44	73	414/45
288	559/45	†83	†151/45
292	265/45	†86	†118/45
295	448/42	95	116/45
299	471/45	†94	†125/45
305	149/45	†98	†71/45
304	601/45	101	562/45
315	257/45	102	55/45
316	51/45	†106	†164/44
321	525/45	†110	†63/45
351	246/45	†112	†235/45
353	526/45	†117	†180/44
344	327/45	118	480/45
352	480/45	†128	†80/44
357	545/44	†130	†85/44
358	446/45	†131	†36/44
360	256/44	132	568/45
361	525/45	†142	†45/44
575(b)	210/45	145	359/45
385	612/44	149	414/45
389	265/45	†150	†65/45
594	197/45	†160	†141/44
598	519/45	162	414/45
409	525/45	†174	†141/44
410	218/45	†175	†36/44
420	525/45	†176	†80/44
455	590/45	†179	†71/44
440	351/45	†180	†164/44
446	265/45	181	188/45
449	102/45	185	49/45
451	587/44	197	255/45
453	525/45	215	241/45
461	480/45	217	505/44
		223	145/45
<u>1945</u>		226	158/44
2	546/44	244	257/45
†9	†188/44	245	265/44
11	520/45	246	446/45
†20	†63/45	263	266/44
25	436/45	284	127/44
†25	†20/44	511	256/45
		515	90/45

Cancelled Order	Superseded by	Cancelled Order	Superseded by
<u>1945 - contd.</u>		<u>1944 - contd.</u>	
315	469/44	†82	†45/45
327	190/45	84	545/44
331	241/44	†117	†208/44
355	612/44	†119	462/45
359	59/45	†122	414/45
360	257/44	127	36/45
392	266/44	151	51/45
406	481/45	135	625/44
412	414/44	†156	†65/45
414	500/45	159	424/45
421	414/45	†141	†240/44
426	481/45	144	294/44
440	116/45	143	414/45
446	25/44	147	561/44
449	649/44	150	321/44
471	205/45	165	414/45
480	630/44	170	254/45
485	116/45	†175	†280/44
491	327/45	199	425/44
497	366/44	216	59/45
503	354/44	221	649/44
519	545/44	223	36/45
521	265/44	†224	†271/44
526	425/44	249	545/44
555	421/45	257	40/45
539	278/45	259	641/44
547	288/45	264	254/45
559	375/44	266	440/45
576	265/44	270	390/44
578	178/45	†280	†44/45
582	414/44	†282	408/45
584	205/45	292	649/44
594	265/44	297	35/45
611	481/45	302	325/45
664	165/45	304	370/45
672	199/45	305	205/45
674	495/44	311	424/45
684	560/44	317	425/44
		337	500/45
		348	645/44
<u>1944</u>		360	300/45
†2	†117/44	364	347/45
10	646/44	375	311/45
†10	†159/44	393	517/44
†13	†56/44	407	215/45
†14	†71/44	413	512/44
17	167/45	416	86/45
†20	†66/45	441	38/45
†35	†80/44	458	215/45
†36	†141/44	484	469/45
39	477/44	489	212/45
†47	†72/44	492	165/45
54	51/45	502	424/45
†64	†72/44	512	180/45
†71	†140/44	526	651/44
76	278/44	538	526/45

Cancelled Order	Superseded by	Cancelled Order	Superseded by
<u>1944 - contd.</u>		<u>1945 - contd.</u>	
552	254/45	34	469/45
567	222/45	†44	†94/45
599	469/45	65	420/45
605	440/45	79	343/45
618	469/45	81	526/45
627	254/45	91	140/45
649	279/45	102	182/45
660	215/45	105	218/45
680	218/45	128	450/45
		160	337/45
<u>1945</u>		180	265/45
9	200/45	184	358/45
†13	†82/45	207	571/45
†25	500/45	235	557/45
53	172/45	267	478/45

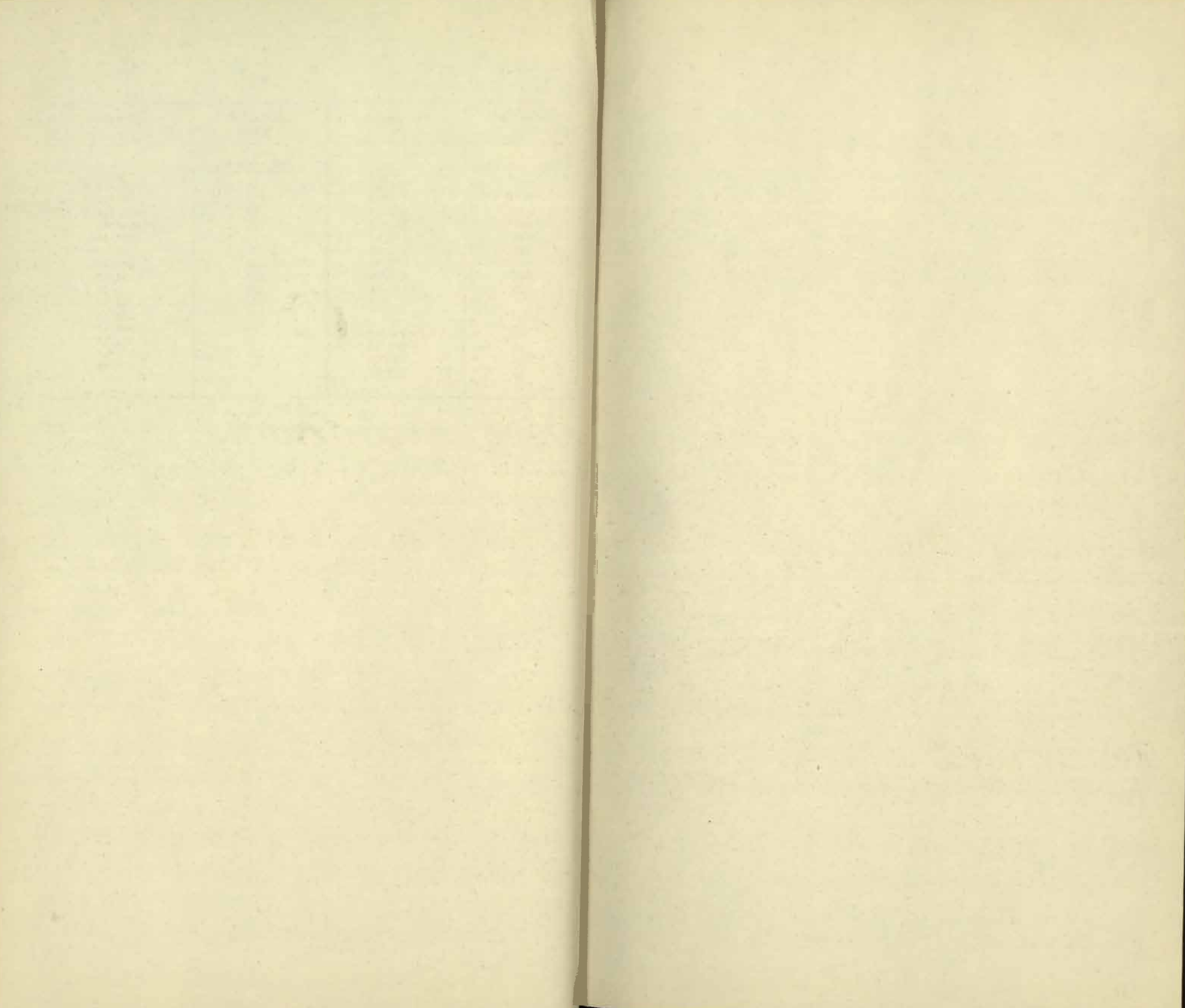

Library

RESTRICTED.

COMMONWEALTH NAVY ORDERS

I N D E X

OF

NAVY ORDERS

1945

COMPRISING

NAVY ORDERS ISSUED BETWEEN

1st JANUARY, 1944, and 30th JUNE, 1945

and

LIST OF NAVY ORDERS CANCELLED

SUBSEQUENT TO 1st JANUARY, 1939.

(This Index is published at the end of each half-year.)

Photo-lithographed, by Authority:
H. E. DAW, Government Printer, Melbourne.

I N D E X

Subject	C. N. O. or C. C. N. O. No.
A	
A.A. Armament - H.M.S. Frigates	†9/45
Fire Control - Calibration Procedures for A.B.U. and Type 285	†225/44
Targets - Kites and Drogues for - Discontinuance of Supply	146/44
Able Seamen - R.A.N.V.R. - Allocation of, to General Service..	176/44
Abnormal Expenditure - Accumulators	181/44
A.C.B. 247 (R) Issue	†85/44
A.C.F. Club for Women Officers in Sydney	164/45
Access to Compartments situated below the waterline which are to be manned at sea	255/44
Accidents - Guns	28/44
- Naval Motor Vehicles	56/44
- Revolvers	86/44
Accommodation - Rail - Adelaide to Melbourne	97/44
- R.N. Dominion and Allied Naval Personnel - Charge for	214/45
Accountant Branch Examinations	648/44
Ratings - Temporary Commissions	366/44
Accounting for Machinery, Machine Tools, etc. supplied for Naval Workshops	108,584/44
Naval Armament Stores, at certain Shore Establishments - Instructions	151/45
Procedure - Naval Armament Stores in D.E.M.S.	515,615/44
Store - Frigates	244/44
Accounts and Storekeeping Arrangements - Naval - Responsi- bility for inspection	99/45
- Armament Store - H.M.A. Ships etc. - Consumable Stores	285/44
for Provisions - Necessity for prompt payment Supplied to Tenders when absent from Parent Ship	217/44
- Naval Armament and Torpedo Store - Errors and omissions, etc.	385/44
- Pay and Service Certificates - H.M.A. Ships attached to Eastern Fleet	612/44
- R.A.N. Destroyers and A.M.S. attached to Eastern Fleet	57/44
Acting Higher Rank - Retention of	415,512/44
Petty Officers - Irregular wearing of Class III Uniform	452,650/44
Rank or Relative Rank of Lieut.-Commander - Naval Reserves - Grant of	106/44
Action Rations607/44;10,41,141/45
Repair and Fire Fighting Materials - Stowage for - Minor War Vessels	645/44
Adaptometer - A.R.L. Mk.III - Classification of Night Vision by	†179/44
Addresses - Seaward Defences	545/44
Administration - Landing Ships	†65/45
Admission of Naval Personnel to Mental Hospitals or Receiving Houses	†208/44
Advance Supply Notes - Despatch of for Naval Stores Shipped etc. from H.M.A. Naval Store Depots	160/44
	642/44

† Denotes C.C.N.O.

Subject	C.N.O. or C.C.N.O. No.
A - contd.	
Advancement of Communication Ratings in (or attached to)	
Combined Operations	557/44
Ratings Serving in Services Reconnaissance Department, Far Eastern Liaison Office and Allied Intelligence Bureau	667/44
Trained in Combined Operations	649/44
Recovered Deserters to Able Seamen of equivalent rating	26/44
Wiremen	556/44
to Chief Petty Officer - R.A.N.R. Petty Officers	290/44
Shipwright - Qualifications	322/44
Petty Officer and Leading Seaman - Professional Examination for	241/45
- Radio Mechanic Branch	360/44
- W.R.A.N.S.	259/45
- W/T Ratings	275/44
Advances - Cash - for Fighting French Warships	†75/44
Aerial - Radar - Y.F.P. - Modifications	†168/44
- Training System A/S1 and A/S3 - Modification to Radar Types A272, A286 P/Q	†81/44
- Trunk - 4-in - W/T - A.M.S. Vessels	260/45
Agencies - Commonwealth Savings Bank - Commission	85/44
Aircraft Operating from H.M.A. Ships - Emergency Rations for	67,445/44
Airgraphs	364/44
Air Mail - India - United Kingdom	363/44
Mails	620/44
or Sea Freight - Stores consigned by - to Northern Operational Bases	167/44
Sea Rescue Vessels - Allocation of Names	412/44
- Physical Standard of Personnel serving in	558/44
Allocation of Radar Equipment	†142/44
R.A.N.V.R. Able Seamen to General Service	176/44
Allowance - Captain of Heads	238/44
- Dragnets	256/45
- Marriage and Child - Sterling Payments	76/45
- Mileage - Private Medical Practitioners attending members of the forces	5/45
- Store - "Bathurst" Class Australian Minesweepers	14/45
Allowances of Accessories - Authorized (Test Equipment) for	†140/44
Australian Type Radar	†257/44
Cartridges S.A. .303 - Revised	†128/44
- Star Shell	†52/44
Alteration(s) and Addition(s) - A.M.S. Vessels - A.F.O. 389/43	†52/44
- Asdic Installations -	
Fairing of Shell	
Plating C.A.F.O.	
2163/43	†102/44
- Fitted for Mine-sweeping - Spur for Additional Signal	
Halliards	†118/44
- Hailing Equipment	
A.F.O. 3963/43	†108/44
- Stiffening of Seatings -	
Kelly and Lewis Steam driven Generators	†104/44
- Voice Pipe Communications	†103/44

† Denotes C.C.N.O.

Subject	C.N.O. or C.C.N.O. No.
A - contd.	
Alteration(s) and Addition(s) - contd.	
- Depth Charge Pattern Control Introduction	†121/44
- Fairmile Patrol Boats Type "B"	†195,†229/44
- C.S.A.	
Smoke Apparatus and Type "F"	
Smoke Floats	†209/44
- Firefighting in H.M.A. Ships A.F.O.	
5593/45	†97/44
- Items	65/45
- Range Transmitter from Radar to Transmitting Station	546/44
- Steam Auto Clave for Sterilization of Dressings etc. in H.M.A. Frigates and H.M.A. Ships "Warrego" and "Swan"	†81/45
- 72 ft. H.D.M.Ls. ex U.S.A.	†256,†291/44
- Ventilation	†79/45
Amendment to "Official Memorandum - Prices of Clothing, etc. Maintained for issue on repayment to Ships' Companies" - dated 1st May, 1945	31/44
of Form A.S.151 - Consumable Naval Store Ledger Sheets	246/44
Quarter Bills	189/44
Ammunition - American 40 mm. - Fitted Tracer Igniter Mark 10 -	
Danger from Ejection	†8/45
- Boxes C222 and C1992,278/44;70,86/45
- Cartridges, 40 mm. Bofors H.E. with Primers No.18 -	
Withdrawal - Report	380/44
- Clip Mark 3 - American - Stoppages	209/45
- Expenditure Returns - Monthly	†271/44
- Gun Armament Material - Failure of - Form S.1148	294/44
- Lighters - Loading for Ocean Passages	†199/44
- Miscellaneous A.A.D. Weapons - Rails, Propelling	
Rocket U2 in Mk.II	42/44
- Propelling Rockets U2 in	
Mk.II and III, Kirby Lots	
32, 33, 136, 178, 179	
and 182 - Restriction	152/44
- Outfits of Small Ships - Arrangements for Periodical Exchange, Examination etc.	325/44
- Practice - 40 mm. Bofors	†36/45
- Pyrotechnics and Rockets, Signal - Star Shell - All	
Calibres - Minimum Range at which satisfactory	
functioning can be expected	195/44
- Q.F. 40 m.m. Bofors Ready Use - H.M.A. M.Ls.	189/45
- Reconditioned Q.F. 2-Pdr. H.E.H.V.	†145/44
- Small Arms - Allowances for Shore Bases	†66,†101/45
- Stock Reports	166/44
- Supply to Northern Bases	†145/44
- Unserviceable American - Disposal	†78/44
- Restricted or Repairable - Disposal of	238/45
- Weekly Report of Stock - by Shore Establishments on	
Form A.O.5Z	326/44
- 4" - Hand up Chutes for - Modification	†180/44
- 40 m.m. Bofors - Policy in Regard to Issue	653/44,30/45
- 20 m.m. Oerlikon - Clearing Charges	151/44
- 20 m.m. and 2-Pdr. - 20 m.m. Oerlikon H.E. - Liability to Caps of Cartridges Blowing Out, when Modified Breech Face Piece (Mark II) are fitted - Withdrawal of certain lots - Reports	142/44

† Denotes C.C.N.O.

Subject	C.N.O. or C.C.N.O. No.
A - contd.	
Amendments - contd.	
- 20 m.m. Oerlikon H.E. Lot H.N.C.15 - Withdrawal ..	309/44
N.F.E.404 - Withdrawal ..	310/44
T.P.C.746 - Withdrawal ..	487/44
Tracer Lot N.F.H.2257 F -	
Withdrawal	307/44
10B/45 -	
Withdrawal	308/44
A.M.S. Vessels - Additional Kit Lockers	†41/44
- Aerial Trunk - 4 in.W/F	260/45
- Allocation of Engineer Officer's Cabin	95/45
- Alterations and Additions	†164, †251/44
- A.F.O.589/43	†52/44
- Asdic Installations -	
Fairing if Shell	
Plating C.A.F.O.2165/43	†102/44
- Depth Charge Throwers	
Mark II Replacement by	
Mark IV - C.A.F.O.	
1964/43, paragraph 2(a)	†86/44
- Fitted for Minesweeping -	
Spur for Additional	
Signal Halliards	†118/44
- Fitting of D/F Equipment	
A.W.A.Type	
C.143A	†85/44
Single Bofors	
Mountings	†176/44
- Hailing Equipment -	
A.F.O.5965/43	†108/44
- Lockers for Fire-fighting	
and Action Repair Mater-	
ials	†65/44
- Stiffening of Seatings -	
Kelly and Lewis Steam	
Driven Generators	†104/44
- Voice Pipe Communications	†103/44
- And Frigates - Modification to Evaporator System	†68/44
- Arrangements for Cafeteria Service - Modifications to	
Galley	123/45
- A/S Type 128 or 128A where fitted - conversion to	
A/S Type 128B or 128C	159/44
- Axial Flow Fans	12/45
- Bridge Communications for A/S work in	†76/45
- Brown Type "A" Gyro Compass	590/44
- Canvas Flag Wallet for	114/44
- Close Range Armament when Single Bofors is fitted	†205/44
- Contamination of Boiler Feed Water with Oil Fuel	275/44
- Deterioration of Cast Iron Condenser Doors	11/44
- Exchange of Ammunition in	520/44
- Gardner Diesel Engines for "L.L." Sweeps -	
Circulating Water Header Tanks	479/44
- Guard Rail Stanchions on Forecastle	†166/44
- Gunnery Communications	†7/44; †40/45
- Hawsers for	168/45
- "L.L." Cable Drums - Stiffening of Hand Winding	
Gear	545/44
Lead - Modification to	†258/44
Sweep Reel - Failure of Hand Winding Gear	339/44

† Denotes C.C.N.O.

Subject	C.N.O. or C.C.N.O. No.
A - contd.	
A.M.S. Vessels - contd.	
- 57/3 Cells for "L.L." Sweeps	†8/44
- Magazines - Battens - Reports	66/45
- Main Circulating Water Inlet Pipes	518/44; 95/45
- Maximum Continuous Power	†162/44
- Modification of - to Steam Driven Boiler Room Fans	195/44
to Firemain at Station 54	370/44
- P.A.C. Projectors	†151/44
Rockets	88/44
- Peacock and Smith Evaporating Plants	126/45
- Pitting in Engine Room Bilges	†69/44
- Propeller Shafts	†62/44
- Radar in	†9/44
- Gyro Compass Repeats for	†41/45
- Refrigerating Plant for Cold Room	210/44
- Refit at Port Adelaide - Replenishment of Naval	
Stores	54/44
- Removal of Helmsman's Splinter Proof Shelter	†204/44
- Repainting of	110/44
- Replacement of 20 m.m. Oerlikons Mk.IIIA by	
Mk.VIIA	227/45
- Shortening of Main Mast	†80/45
- Stability	†177/44
- Steel Chests for	182/44
- Use of Fore Peak for Trimming Ship	†45/44
- Ventilation of Wardroom Pantries	†89/44
- Vibration of Steam Driven Boiler Room Fan Engine	†123/44
Anchor Cable - Additional Securing Arrangements for "B" class M.Ls.	†72/45
Annual Census - Office Machinery	22/44
Inspection of Explosives ex H.M.A. Ships	111/44; 50/45
Anti-Aircraft Targets - Kites and Drogues for - Discontinuance	
of Supply	146/44
- Cholera - Inoculation	673/44
- Flash Gear	51/45
- Gas Clothing - Oilskin - Upkeep and Repair	21/44
- Eyeshields and Ointment - Revision of Allowances	209/44
- Protection	549/44
- Respirators - Care of	79/45
- Painting of Haversacks	382/44
- Glare Spectacles - Pattern 4074 - Supply	30/44
- Polarised Sun Glasses -	
Replacement by	281/44
- Malarial Measures for Operational Forces Destined for	
Service in Malarious Area	418/44
- Supply of Stores for	15/44
- Ship Fire Control - Communications - Radar Observation	
of fall of Shot	†259/44
Apparatus A.D. Type "L"	22/45
Applications from Naval Personnel for Discharge	205/44
Appointment(s)	316, 677/44
- Port Division Naval Medical Officer - Geelong	622/44
- Where date is to be reported - Reports	532/44
Apprentices - War Service	291/44
Armament - Additional - Gate Vessels and Boom Working Vessels ..	†57/44
Depot, R.A.N., Fremantle - Title of Officer-in-Charge	84/45
- Naval Depot, Darwin	†146/44
- H.M.A. Ships - Additional Fitting of	†46/44
Material and Ammunition - Failures of - Rendering of	
Forms S.1148 (h), (i) and (j)	294/44

† Denotes C.C.N.O.

Subject

A - contd.

O.N.O. or
C.C.N.O.

Armament - contd.	
Store(s) - Accounting at Certain Shore Establishments -	
Instructions for	151/4
- Issued by U.S. authorities	224/4
- Matters - Naval - Correspondence on - Naval	
Officer-in-Charge, Brisbane	174/4
Arms, Small - Establishment for Shore Bases	†20/4
Army Medical Facilities - Use of in Transfer of Invalids	641/4
Salvage Service - Salvage of Condemned, Unserviceable etc.	
Stores	267/4
Arrangements in respect of the Agreement between U.K. and	
Australian Governments for H.M. Ships transferred to R.A.N. for	
manning	†51, 227/4
A/S and Radar Maintenance Vessels - Naming of	†198, †260/4
Directing Gears; Pattern A.810 - Types 128 and 144 Series	†185/4
Equipment - Half-yearly Reports on - Record of Personnel	†148/4
in M/Ls - R/T Interference	61/4
Installations - Modification Stores	†99/4
- Tuning of	†62/4
Recorders - Dessicators for	†12/4
Sets Fitted with Electrical Training Brushes for Motors	
Patt. 9955 and 9956	†265/4
Type 128 or 128A where fitted - A.M.S. Vessels - Conver-	
sion to A/S Type 128B or 128C	†139/4
W/T. Radar, etc. Equipment - Establishment Lists	311/4
Asdic Installations Types 144/5 - Training of Personnel	†70/4
Sets in H.M.A. Frigates and H.M.A.S. "Orara" and "Kybra"	†185/4
Stores - Packages Containing - Marking	†98/4
Assistance for War Correspondents - Publicity	184/4
Atebrin - Suppressive Treatment (Prophylaxis) for Malaria	240/4
Aural Care and Selection of Submarine Detector Ratings	391/4
Australian Army Canteens Service Issuing Points	484/4; 54/4
Defence Canteens Service Clubs	47/4
Minesweepers "Bathurst" Class - Store Allowance	14/4
Red Cross Society	544/4
Authorized Allowances of Accessories (Test Equipment) for	
Australian Type Radar	†140/4
Automatic Morse Operators and T/P Visual Signallers, Coders -	
W.R.A.N.S. - Advancement	20, 55, 128, 204/4
Awards, Decorations and Honours to Naval Personnel	200/4

B

Badges - Controlled and Observation Mining Ratings	7/4
- D.E.M.S. Gunnery Ratings	95, 338/4
- for War Service	257/4
- Service, R.A.N.R. - Deprivation and Restoration	61/4
- Officers' Cap	257/4
Ball and Roller Bearings - Procurement	4/4
Band Instruments - Orchestral - Percentage Charge and Grants-in-Aid	197/4
Bank Agencies - Commonwealth Savings - Commission	85/4
Base Spares - Propellers and Tailshafts	371/4

† Denotes C.C.N.O.

Subject

C.N.O. or
C.C.N.O. No.

B - contd.

Batteries - Low Power - Mounting on Resilient Mountings in Order	
to Reduce Effects of Shock	†232/44
- Main Low Power - Increased Capacity	†276/44
Beach Unit - R.A.N. - Mail Address	†7/45
Beacon(s) - Radar	†141/44
- Euston Reef - Radar Reflector	†119/44
Beckets - Reeving of - Clips Cartridge No.25	164/44
Bed Linen - Clothes Rationing	185/44
Bedding for W.R.A.N.S.	169, 218, 586/44
- Wartime Allowances - R.A.N. Shore Establishments	469/44
Beer - Bottled - Supply to H.M.A. Ships and Establishments in the	
New Guinea Area	81/45
Bilges - Pitting in Engine Room - A.M.S. Vessels	†69/44
Bills of Lading and Consignment Notes - Return of Receipted	
"Extra" copies	195/45
- Quarter - Amendments	189/44
Binoculars - for D.E.M.S.	252/44
- Precautions regarding security before use	196/45
- Telescopes, Watches and Heliographs - Muster of	597, 595/44
Blankets and Mess Gear - Issue to Personnel travelling	254/45
Bofors - Guns - Care and Maintenance	165/44
- Improved Unloading Mask	42/45
H.E. Ammunition - Cartridges 40 m.m. - Fitted with	
Primers No.18 - Withdrawal, Report	580/44
O.Q.F. 40 m.m. - E.F.C. Valves	578/44
- Pitting of Standard Grid Sights -	
Single Mountings	129/45
- Liquid in Recoil Buffers	375/44
- Locking of Screws, Securing Bracket	
Supporting Buffer - Fitting of	
Shock-proof Washers	466/44
- Series Inspection	67/45
- Springs Striker Inner and Outer	222/45
Q.F. 40 m.m. Ready Use Ammunition - H.M.A., M.Ls.	189/45
40 m.m. - Ammunition - Policy in regard to issue	655/44; 50/45
Practice	†56/45
Mk.I and I* (Naval) Aust. Manufacture	486, 577/44
- Modification - Breech Casing	
right front	429/44
- Cartridge Deflector	451/44
- Left Rear of Breech Casing	455/44
- Safety Lever Indicator	452/44
Mark IIIA Gun Mountings - Modification of earlier	
Pattern Pedestals	228/45
- Single - Supply of Sights	
Correctional	
40 m.m. A.A. Mtgs.	130/45
- Mk.V Aust.	57/45
- Slewing Handles to be	
Fitted	450/44
Boiler Feed Water - Contamination of by Oil Fuel - A.M.S. Vessels	275/44
Boilers - Combustion Cones for - Permanent Naval Stores	91/44
Water - Hydrometers, sensitive Glass - Pattern 37A	187/45
Tube - Use of Shore Water for	†161/44
Bombs and Mines, Disposal Work - First Aid Precautions	686/44

† Denotes C.C.N.O.

Subject	O. N. O. or C. C. N. O. No.
B - contd.	
Books and Forms	55,78,102,129,185,198,247,268, 299,541,558,559,588,422,470, 481,511,523,554,575,602,616/44; 7,57,46,75,159,190,225/45
Local Secret and Confidential -(See Local Secret and Confidential Books)	
Boon Defence Depots - Establishment of, at Cairns, Townsville, Port Kembla and Port Moresby	58/44
Boots - Football - Amended Issuing Price	536/44
- Rubber Sea - Oilskin Clothing - Storage of	245/44
Boxes Ammunition C.222 and C.199	2,278,416/44; 70,86/45
W.76 and W.76E	71/45
B.R. and O.U. Books Account	600/44
797 - Handbook on Lockouts and Service Optical Instruments - 1943 - Amendments	340/44
826/43 and B.R.861/45 - Drill for Fuze-keeping Clock	24/45
Branch-Coding	16/44
- Pass Professional Examination	60/44
Branches - Ordnance and Electrical Mechanic	82/44
Breathing Apparatus, Pattern 5485 - Salvors Self-contained	98/45
Breech Mechanism - Modification to O.Q.F. 4'7" Mk.XII, XII* and XIIB	579/44
Bridge Chart Table Modification to - Escort Vessels fitted with Radar	†154/44 †51/45
Communications for A/S Work in A.M.S. Vessels	†76/45
Bright Steel Bolts, Nuts and Studs, manufactured from Marbrite Free Cutting Steel	594/44
British Naval Office, San Francisco	8/45
Broadcast Receivers - Commercial Types.. .. .	615/44
Bursaries for children of Personnel Killed or Disabled during the War	65/45
Business Member - Naval Board of Administration	105/44
Butter, Concentrated, Hardened - Replacing Butter Fat Spread	563/44
- Economy in Consumption of	115/44
Butts for .505" Vickers Machine Guns on Single A.A. Mounting	477/44

C

Canned Meats - Warranty period for	68,255/44
Canteen Arrangements in R.A.N. - Revised - and Establishment of an R.A.N. Central Canteen Fund	484/44
Stores for H.M.A. Ships	198/45
Canteens - Australian Army - Issuing Points	599/44;54/45
- Service System in Frigates and A.M.S. Vessels	446/44
- Administration of, in H.M.A. Ships and Establishments where no Account- ant Officer is borne	618/44
Stores - Supply of	285/44
Canvas Flag Wallet for A.M.S. Vessels	114/44
Hose Tubing - Prolonging life	92/44
Cap Badge(s) - Officers'	257/45
Caps - Blue for Officers and Men proceeding to the United Kingdom	46/44
Captain of Heads Allowance	258/44

† Denotes C.C.N.O.

Subject	C. N. O. or C. C. N. O. No.
C - contd.	
Carriers - Ammunition, Double, for O.Q.F. 4" Mk.XIX and O.Q.F. 4" Mk.XVI*	328/44
Cartridges - Cases - Q.F. 4" XVI* Gun - Withdrawal	44/44
- Marking of, with Sub-Lot XJ	54/44
- M.L.9.5 in D.C.T. Cordite H.S.C.T. -134-055, 4-oz.0 drms. Mk.XII - Introduc- tion of	†73/44
124/058, 5-oz.14 drms. Mk.II - Withdrawal	65/44
- S.A., Ball 9 m.m. of D.I.L. manufacture - Restriction	95/44
.455" Ball, Revolver - Mark II - withdrawal	188/45
- M.Q.23/12/42 - Withdrawal	194/45
- Signal 1 in. White Mk.IXT. of M.E. Filling - Lots 8-16 inclusive - Withdrawal	96/45
- 40 m.m. Bofors H.E. fitted with Primers No.18 - Withdrawal - Reports	380/44
Case Markings - Shipment of Mining Stores	59/45
Cash Advances to Fighting French Warships	†75/44
H.M.A.Ships from U.S. Ships	303,675/44
Vouchers and Forms - Captain's Signature	130/44
Cells - L.L. 57/3 - For L.L. Sweeps - A.M.S. Vessels	†8/44
Censorship - Naval	23,98,177/44; 213,242/45
Census - Annual - Office Machinery	22/44
Certificates - Disposal of, on Reversion - R.N. Ratings on Loan to the R.A.N.	190/44
- Naval Watchkeeping - Naval Reserve Officers	256,319/44
- P.M.G. - Examination for - Eligibility of Tele- graphist Ratings for Exemption in certain subjects	75/44
- Service and Pay Accounts - H.M.A. Ships attached to Eastern Fleet	57/44
Cessation of Hostilities in Europe	217/45
Chart Folios - Establishment in H.M.A. Ships	†190/44
Chests - Steel, for A.M.S. Vessels	182/44
Chevrons for War Service	219/44
Chief Petty Officer - Advancement to - R.A.N.R. Petty Officers . Shipwright - Advancement to - Qualification	290/44 322/44
Chlorosulphonic Acid Mixture Drums - Precautions to be observed when returning	61/45
Chocolate and Confectionery for Naval Canteens	408/44
and Messes	158/44
Cholera - Inoculation against	†149/44
- Precautions against	4/45
Chutes - Hand-up for 4" Ammunition - Modification	†180/44
Cigarettes and Tobacco - Naval Personnel proceeding on Leave or Discharge - Supply of	82/45
Cinema Branch - Adoption in the R.A.N.	202/45
Claim Forms for Compensation - for Total Loss of Uniform Clothing - Ratings - Introduction of Forms A.S.103Y and A.S.103Z	242/44
Claims for Pilotage	3/45
Clasp to 1939-43 Star	56/45
Classification of Night Vision by A.R.L., Adaptometer (Mark III) - Security	†203,411/44
Clearing Charges - Ammunition - 20 m.m. Oerlikon	151/44
Clips Cartridge No.25 - Reeving of Beckets	164/44
No.1 Mark I	559/44;229/45
- Inglefield and Unserviceable Flags - Return to Store	69/44

† Denotes C.C.N.O.

Subject	C.N.O. or C.C.N.O. No.
C - oontd.	
Clothes Rationing	630/44
Clothing and Uniform - W.R.A.N.S. - Gymnastic Shoes	19/44
- Civilian - Supply of, to Members of the Naval Forces on Discharge	214/44
- Issues - Special - for Personnel in Forward Island Areas	224,282,495/44;89/45
- Maintained for Issue on Repayment to Ships' Companies - Amendment to Official Memorandum	31/44
- Oilskin Anti-Gas - Upkeep and Repair	21/44
and Rubber Sea Boots - Storage of	245/44
- Prices of - Maintained for Issue on Repayment to Ships' Companies - Official Memorandum	285/44
- Protective	251/44;136/45
- Rationing - Bed Linen	183/44
- Repayment - in Tenders	492/44
- Supplies and Uniform - Repayment Issues of Materials	171/44
- Repayment - in Tenders	165/45
- Supply to Civilian Crew of R.A.F.A. "Kurumba"	240/45
Clubs - A.C.F. for Women Officers - Sydney	164/45
- Australian Defence Canteens Service	47/44
- Naval, Military and Air Force - Adelaide	178/45
Coal for H.M.A. Ships - Procedure governing supplies	32/44
Coastal Craft - Reports of Proceedings	†19/45
- Section - Formation	652/44;77,204/45
Code - Ammunition etc. - for Signalling requirements	†275/44
and Cypher Machines - Installation in H.M.A. Ships	†112,†288/44
Coders, Visual Signallers, T/P and Automatic Morse Operators, W.R.A.N.S. - Advancement	204/44
Coding Branch	148/45
- Pass Professional Examination	60/44
- Re-examination for Ordinary Coder	16/44
Machines and Spare Parts - Transport of	†24/44
Cold Room - Refrigerating Plant for A.M.S. Vessels	210/44
Combined Operations - Advancement of Ratings Trained in Section - Senior Naval Officer	649/44
Combustion Cones for Boilers - Manufactured from Heat Resisting Steel	127/45
- Permanent Naval Stores	91/44
Comforts forwarded to H.M.A. Ships and Establishments - Acknowledgment of	606/44
Commander - Qualification for promotion to - Officers promoted direct from Warrant Rank to Lieutenant	11/45
Commendations by Commander-in-Chief	†34/45
Commission - Commonwealth Savings Bank Agencies	85/44
Commissioning of H.M.A. Ships, etc., (see H.M.A.S.)	566/44
Commissions - Temporary - Accountant Branch Ratings	414/44
- Coder Ratings	474/44
- Selection of Ratings from Lower Deck	219/45
- Engineering Branch	200/45
- Special Branch R.A.N.V.R.	629/44
Commonwealth Legal Service Bureaux	670/44;115/45
Reconstruction Training Scheme	85/44
Savings Bank - Agencies	†254/44
Communicable Diseases - Introduction to New Guinea and Australia Communication(s) - Depth Charge	†21/44
- Flags - British - U.S.	159/45
with the Press	135/44

† Denotes C.C.N.O.

Subject	C.N.O. or C.C.N.O. No.
C - oontd.	
Compass - Gyro - Repeats for Radar in A.M.S. Vessels	†41/45
- Magnetic - Effect of Telephones on	355/44
- Sperry Mk.XIV Mod.I Gyro - Incorrect Fitting of Trans- mitter Connecting Cables	514/44
Compassionate Drafts	†194/45
Compensation for Loss of or Damage to Uniform and Clothing Articles Tools	184/44
Total loss of Uniform and Clothing - Officers and Ratings	561/44
Components of Admiralty Type Radar	†282/44
Compulsory making of Wills	220/44
Concession Railway Fares of Service Personnel Travelling in Uniform and Paying their own fares	645/44
Travel - for Members of the Forces - in N.S.W.	355/44
Condemed, Unserviceable etc. Stores - Salvage of - Army Salvage Service	287/44
Confidential and Secret Correspondence - Security	†99/44
Correspondence - Registration	500/44
Messages - Transmission in Plain Language over Teleprinter Channels	98,155/44
Navy Orders - Issue of	†1/44
Reports on Naval Reserve Officers	427/44;40/45
Confirmation and Promotion of Naval Reserve Officers	501/44
Provisional Promotion for R.A.N.R. and R.A.N.V.R. Officers in time of war	681/44
Consumable Naval Store(s) Ledger Sheets - Amendment of Forms A.S.151	246/44
- Naval Armament Stores Account - H.M.A. Ships, etc.	585/44
Consumption of Butter - Economy	115/44
Contract(s) Rates - Fresh Provisions - At Melbourne	101/44
Supply of Ratings' Made-to-Measure Uniforms	405,508/44;121/45
W.R.A.N.S. Ratings' Made-to-Measure Jackets and Shirts406,628/44;120/45
Control Gear and Electrical Switch - Mounting on Resilient Mountings to reduce effects of shock	†242/44
of Venereal Disease - Melbourne Area	†40/44
- Prophylactic Centres	†152/44
Controlled and Observation Mining Ratings - Badges	7/44
Convalescent Home for Women's Services	284/44
Convoy Escort Organisation	†51/44
Plotting Board	†251/44
Signal Ratings	104/45
Cooks - W.R.A.N.S. - Galley Shoes for	77/44
Cordage - Precautions to Prevent Deterioration	154/45
Cordite Landing	90,180/44
Records - Maintenance on Board H.M.A. Ships	89/44
Temperature Returns and Sub-lot Markings - R.A.F.As. Auxiliary A/S and M/S Vessels and M.Ls.	51/45
Correction(s) to Local Secret, Confidential and O.U. Books	†170,†182,†189,†200, †215,†255,†285/44; †22,†47,†67,†91/45
Correspondence - H.M.A. Radar School	441/44
- London	604/44
- Naval Store Depot, Melbourne	55/45
on Naval Armament Store Matters - Naval Officer-in-Charge, Brisbane	174/44
Orderlies and Postmen	259/44
- Secret and Confidential - Instructions re - acknowledgment, custody, disposal, etc	†58/44

† Denotes C.C.N.O.

Subject	C.N.O. or C.C.N.O. No.
C - contd.	
Corrigendum to Navy Order 528 of 1943	226/44
24 of 1944	96/44
54 of 1944	131/44
66 of 1944	103/44
71 of 1944	116/44
169 of 1944	218/44
266 of 1944	389/44
412 of 1944	463/44
523 of 1944	574/44
666 of 1944	16/44
146 of 1945	201/44
†294 of 1945	†18/44
Cots - Stretcher - Pattern 474 - Supply	243/44
Counter - Measures to Acoustic Homing Torpedo - F.X.R. Gear	†120/44
Counterpanes, Coverlets and Mattress Covers - Return to Store of Numbers held in Excess of Allowance	598/44
Coupons - Food - Naval Personnel	286,605/44
- Special Issue for purchase of Nightwear - R.A.N. Women's Services	64/44
Course and Examination for Chief Ordnance Artificer	451/44
Courses - Navigation	59/44
Cremation of Deceased Service Personnel	323/44
Custody of Keys of Safes and Chests in Small Ships	†52/44
Customs Duties on Goods sent or brought to Australia by Personnel - Remission	154/44
Cylinder Liquid - Test of Recoil - Gun Mountings	192/44
Cylinders - Gas - Contractors - Return of	99/44
- Empty - Return of	48/44
For Industrial Gas	262/44
- Water Pressure Test	295/44; 60/44
Cypher and Signal Logs - Disposal of	†44/44

D

Damage to Mail received at Milne Bay	437/44
Darwin and Thursday Island - Period of Shore Service at Naval Armament Depot	680/44
Base Organization	146,†212/44
Torpedo Depot	235/44
Deafness due to Gunfire - Recording in Medical Officer's Journals	†56/44
Deaths - Information to be forwarded where personnel die from disease or injury	672/44
Deceased Personnel - Letters found amongst effects of Service Personnel - cremation of	229/44
Defences - Seaward - Addresses	36/44
Deferred Pay of Mobilized personnel	523/44
Delegation of Authority - Supply of Spectacles	†63/44
Demobilization - Requests - Medical Officers	27/44
Demolition Stores - Electrical - Withdrawal of	297/44
D.E.M.S. - Binoculars for	19/44
- Gunnery Equipment - Painting of	571/44
Ratings - Badges	232/44
- Ratings, Drafting records, etc.	330/44
	93,338/44
	320/44

† Denotes C.C.N.O.

Subject	C.N.O. or C.C.N.O. No.
D - contd.	
Dental and Medical facilities in the New Guinea Area - R.A.N.	†272/44
Treatment for R.N. Personnel	171/45
Work - Quarterly return of	655/44
Dependants of Members of the Forces who have married abroad - Passages to Australia for	392/44
Depth Charge(s) and Associated Stores - Weekly Stock Reports	†72,†135/44
Chutes - Modification to Method of Securing to Deck - Motor Launches	†16/44
- Repositioning - M.Ls.	152,†184/44
Communications	†21/44
Dropped for Practice	13/45
Expenditure, six months ending 31st December 1943 - Analysis	†42/44
30th June - 1944 - Analysis	†181/44
31st December 1944	†33/45
- Gassing in	28/45
Mark VII - VII* Filled Minol	†106/44
- Minimum Speeds for firing Depth Charge Patterns	†188/44
- Minol filled - Allocation of	†277/44
Pattern Control - Introduction - Alterations and Additions	121/44
Patterns - Minimum Speeds for Firing	188/44
Pistols - History Sheets - Details required	145/44
- Form O426	94/44
- Mark VII - Modification to Mk.VII*	27/45
- VII* Reg. No.4614	684/44; 210/45
- Restrictions on issue	415/44
- Plugs Wood, Primer - Tube Stamp No.6053	165/44; 69/45
- Practice Expenditure	†122/44
- Thrower(s) - Mark II - Replacement	†25/44
- IV - O.M.L. 9.5" - Use of Correct Description	532/44
- IV - O.M.L. 9.5 in.	†21/45
- Securing Strap - Supply of Spare Wire Spans	381/44
- Modification of Tumbler Hook	207/45
- Pistols - Spare	60/44
- Type (M) and Depth Charges Mark VIII - Defective Bungs Charge Case	196/44
- Use of, in Shallow Waters	†261/44
Deserters - Recovered - Advancement of	26/44
Desiccators for A/S Recorders	†12/45
Despatch of Naval Armament, Gunmounting and Torpedo Stores to Melbourne	43/44
Personnel to Ships and Establishments in New Guinea Area Sydney for Medical Observation or treatment not requiring Hospitalization	450/44
Destroyers and A.M.S. attached to Eastern Fleet	258/44
Detention Barracks - Military - Uniform and Clothing of Ratings in or Imprisonment - Maintenance of Wives and Children of Members of the Forces undergoing	413/44
Deterioration of Cast Iron Condenser Doors - A.M.S. Vessels	356/44
Detonators - No.25, Mark I - Withdrawal of	85/45
- Percussion, Watertight, Mark VII Lot 141 B.R.8/41 - Withdrawal	11/44
D/F and W/T Charging Resistances	100/44
Diaphragms I.R. - to be fitted to Depth Charge Pistols	41/44
	†31/45
	29/44

† Denotes C.C.N.O.

Subject

D - contd.

Directing Gear - A/S Sets Type 126 and 144 Series	†185/44
Director of Women's Royal Australian Naval Service	17/45
Discharge - Applications from Naval Personnel for	205/44
from R.A.N. on account of Physical Unfitness for	
Service	116/45
Discharged Naval Personnel - Rehabilitation Procedure for	14/44
Discrepancies in Stores Shipped Reports A.D.690 and O.9	51,360/44
Disease - Communicable - Introduction of in New Guinea and	
Australia	†254/44
Disposal of Cypher and Signal Loss	†44/44
Mines rendered safe	251/44
Obsolete and Unserviceable Films - Instructional Films	296/44
Unserviceable American ammunition	†78/44
Restricted or Repairable - Disposal of	238/45
Divers - Selection of Ratings for	149/44
Diving Equipment	†105/44
Non-Substantive Rating	565/44
Draft - Medical Examination prior to	120/44
Drafts - Compassionate	†94/45
Drafting of Personnel - Malaria Control	118/44
- W.R.A.N.S.	159/44
Dragnets - Allowance	256/45
Dress, Officers'	†30/44
Drill Tunics with Blue Facings	71/44
Drogues and Kites for Anti-Aircraft Targets - Discontinuance	
of Supply	146/44
Duke of Gloucester's Standard and Governor General's Flag - Flying	140/45

E

Ear Nose and Throat Specialist - Consultant	26/45
Eastern Fleet - H.M.A. Ships attached to - Service Certificates and	
Pay Accounts	37/44
Economy in consumption of Butter	115/44
Education and Vocational Training - Director	619/44
Educational Service - R.A.N. - Reconstruction Training Scheme	524/44
Test 1 - Results - September 1945	81/44
- December 1945	203/44
- March 1944	518/44
- June 1944	475/44
- September 1944	668/44
- December 1944	147/45
- Higher - R.A.N. - Results - October 1945	156,248/44
- April 1944	439/44
- October 1944	25/45
Electric Fans - H.D.M.Ls.	279/44
Electrician and Ordnance Mechanic Branches	82/44
- Equipment in Motor Launches - Replacements	562/44
- Switch and Control Gear - Mounting on Resilient	
Mountings in order to reduce effects of shock	†242/44
Eligibility of telegraphist Ratings for exemption in certain	
subjects of the examination for P.M.G. Certificates	75/44

† Denotes C.C.N.O.

Subject

E - contd.

Emergency rations for Aircraft operating from H.M.A. Ships	67,445/44
Transmitter - Receiver in Frigates	†58/45
Water ration for personnel at sea - Supply of Water	
Bottles	136/44,6/45
Empty Gas Cylinders - return of	48/44
Enemy Ammunition	585/44
Equipment	522/44
War Material and Explosives Stores - Packing and Transport	†73/45
Engine Register - M.Ls.	162/44
Room Bilges - Pitting in - A.M.S. Vessels	†89/44
Ratings - Examination of - Results - September 1945	15/44
- March 1944	344/44
- September 1944	103/45
Engine Officer's Cabin - A.M.S. Vessels	95/45
Engines - Internal Combustion - Preparation for stowage, etc	
after removal from boat	682/44
Equipment - A/S in M/Ls. - R/T Interference	†61/44
- Diving	105/44
- Fire Fighting - Trials - Reports	161/44
- I.F.F. - Return of Type A.B.K. Sets to Store on	
replacement by Radar Type 253	†96/44
- Life Saving - Red Distress Signals and Benzidine Tablets	†154/44
- Sleeves and Torches for Inflatable Lifebelts	126,212/44
- Radar - Allocation of	†142/44
- Test - A.M.S. Vessels	†14,†71/44
- U.S.N. Type Radar - Spares for	†33/44
- Web - Pattern 1937	137/44
- W/T Testing - for Frigates	194/44
Escort Organization - Convoy	†51/44
Refresher Training Organization	†55/44
Vessels fitted with Radar - Modification to Bridge	
Chart Table	†154/44;†51/45
Establishment Lists - W/T, A/S, Radar etc Equipment	511;502/44
of Chart Folios - H.M.A. Ships	†190/44
Establishments - H.M.A. Shore - Name Ships	270/44
- of Small Arms for Shore Bases	†20/44
- R.A.N. - Naval Stores	625/44
Euston Reef Beacon - Radar Reflector	†119/44
Evaporating Plants - Peacock and Smith - A.M.S. Vessels	126/45
Evaporator Systems - Modifications to H.M.A. Frigates	†150/44
Examination(s) - conduct (non-service)	245/45
for Petty Officer Writer and Supply Petty Officer	575/44
the rank of Paymaster Lieutenant-Commander, R.A.N.	202/44
Lieutenant-Commander(s)	182/45
of Engine Room Ratings	555/44
- Results - September, 1945	13,191/44
- March, 1944	344/44
- September, 1944	103/45
Sick Berth Staff - Results - November, 1945	104/44
- May, 1944	438/44
- November, 1944	18/45
- W.R.A.N.S.	250/45
- Professional - for Advancement to Petty Officer	
and Leading Seaman	241/45
Warrant Engineers and Warrant	
Mechanicians	554/44;245/45
Writer and Warrant	
Supply Officer	555/44;244/45

† Denotes C.C.N.O.

Subject	C.N.O. or C.C.N.O. No.
E - contd.	
Executive Officers - Radar Courses for	†115/4
Expenditure - Abnormal - Accumulators	181/4
- D.C. - Six months ending 31st December, 1942 - Analysis 1943	†42/4
on behalf of Netherlands - Classification	187/4
Explosives ex H.M.A. Ships - Annual inspection	111/44;50/4
- Periodical Examination	277/4
- Storage in buildings other than Magazines or Ex- plosives Stores	569/4
Extra Duty Allowance not payable - R.A.N. Women's Services	253/4
Extractors - O.Q.F. 4-in. Mark XVI* Guns	†11/4
Eye Shields - Anti-Gas - and Ointment - Revision of Allowances	209/4
F	
Failure of Armament material and ammunition - rendering of Forms S.1148(h), (i) and (j)	294/4
Gun Armament material and ammunition	144/4
Failures - P.A.C. Rockets	5/4
Fairmile Patrol Boats Type "B" - Alterations and Additions	†195,†229/4
- C.S.A. Smoke Apparatus and Type "F" Smoke Floats	†209/4
Rudders	295/4
Type "B" Motor Launches - Slipping of	12/4
Fan Engine - Steam Driven Boiler Room - Vibration of - A.M.S. Vessels	†125/4
Ventilating - Loss of	66/4
Fans - Electric - H.D.M.Ls.	279/4
- Steam Driven Boiler Room - Modification to A.M.S. Vessels	195/4
Fares - Concession Railway - Service Personnel travelling in Uniform and paying their own fares	645/4
of Relatives attending funerals of deceased service personnel - payment of	274/4
Feed Pumps - Weir Type	504/4
Fenders - Wattle Rod	280/4
Fighting French Warships - Cash advances for	†75/4
Filling Recoil Cylinders - 4-in. Gunmounting Marks XXIII and XXIII*	145/4
Films - Instructional - Disposal of Obsolete and Unserviceable Films	296/4
- Training, and Film strips held on board - Return of	74/4
Fire and Smoke Risks in H.M.A. Ships, Reduction of - Types of Paint to be used for interior painting	369/4
Control arrangements - H.M.A. Frigates	124/4
Extinguishers for Motor Launches	659/4
- Recharging of Cylinders for "Nuswift", "Groviner" and "Essex" Type	†179/4
Fighting and Action Repair Materials - Stowage for - Minor War Vessels	261/4
- Equipment - H.D.M.Ls. and Other Small Craft	58/4
- Life Lines	161/4
- Trials - Reports	†97/4
in H.M.A. Ships - Alterations and Additions - A.F.O. 5393/43	664/4
School	221/4
Precautions in Cinema Projection Rooms	

† Denotes C.C.N.O.

Subject

C.N.O. or
C.C.N.O. No.

F - contd.

Fireman at Station 54 - Modification - A.M.S. Vessels	370/44
First Aid Medical Kits	70/44
Fitting of Additional Armament in H.M.A. Ships	†46/44
Flag(s) Lockers	135/45
on Commonwealth Buildings	6/44
- Precautions to be taken in washing	537/44
- Unserviceable and Inglefield Clips - Return to Store	69/44
- Wallet - Canvas, for A.M.S. Vessels	114/45
Flashless Propellant	†144/44
Flotation - Lifesaving Equipment	132/45
Flour - Tax, refund of	459/44
Food Coupons - Naval personnel	266,605/44
Rationing and Food Economy - General Instructions	265/44
- Wastage of	†16/44
Football Boots	536/44
Foresights - 40 m.m. Bofors Gun Mountings	548/44
Form A.M.2Z - Prevention of Disease and Maintenance of Health in Tropical Climates	539/44
A.M.114Z - Report of Seasickness	449/44
A.M.177G - Medical Store Account for Scale "C" Medical Store	222/44
A.M.301Z - Medical Status of Personnel recommended to be in- validated - introduction	347,510/44
A.S.103Y and A.S.103Z - Introduction of	242/44
A.S.151 - Consumable Naval Store Ledger Sheets - Amendment of	246/44
A.S.155X - Record of Naval Store Ledgerkeepers - Introduc- tion of	298/44
A.S.539Z - "Long Leave Book"	9/44
N.A.5 - Consecutive Number of paid voucher to be inserted by Paying Office	255/44
N.M.T.7 - Instructions for drivers of Naval Motor Services	689/44
O.426 - History Sheets for D.C.Pistols	94/44
S.102 and 103 - Records of issue and return of loan clothing	601/44
S.1147A - Quarterly return of temperature of storage of Cordite - Non-rendering	†100/44
S.1148	421/44
Forms and Cash Vouchers - Captain's signature	150/44
Books - see Books and Forms	
- Medical and Rehabilitation - Completion of, for Dis- charged Personnel	692/44
- Printed	409/44
Forwarding of C.W.1 Forms	79/44
Free Kits - Issue of, to Ratings on entry	154/44
Freight and travelling warrant books - Disposal of	659/44
Fremantle - Torpedo Depot	†65/44
Fresh Provisions - Contract Rates - at Melbourne	101/44
Water supplies in H.M.A. Ships	658/44
Frigates and A.M.S. Vessels - Modification to Evaporator System	†68/44
- Emergency Transmitter - Receiver in	†58/45
- H.M.A. - Modification to Evaporator System	†150/44
- Low Power Supply System	†16/45
- Naval Store Accounting Procedure	244/44
- Special arrangements for oiling at Sea - A.F.O.4159/44	†59/45
- With reciprocating main engines - maximum continuous power	†53/44
Fruit and tomato juices - extra issues of	199/45
Fuel Oil - Naval Stocks in Australia	†15/44
Funerals of deceased service personnel - payment of fares of relatives attending	274/44
- Payment of Contractors' claims in connection with	230/44

† Denotes C.C.N.O.

Subject

F - contd.

Furniture - Steel - Supply to H.M.A. Ships	356/4
- Wooden - Replacement by Steel, in Cruisers, Destroyers, A.M.S. Vessels and "Warrego" and "Swan"	354/4
Fuses - No.401, Mark II Lot 146 V.A.O. filled 10/41 - Withdrawal from service for 100 per cent examination	55/4
- Percussion D.A. No.250	32/4
- Time No.401 Marks I and IA	153/4
- On Board H.M.A. Ships - Annual percentage in wartime	253/4
F.X.R. Gear - Counter measure to Acoustic Homing Torpedo	†120/4

G

Galley Shoes for Cooks - W.R.A.N.S.	77/4
Gaols - Civil - Maintenance of United States Naval Personnel in Garbage and ashes from H.M.A. Ships at Outer Harbour and Port Adelaide - Disposal of	113/4
Gas Cylinders - Return of Empty	90/4
Contractors'	48/4
- Water Pressure Test	99/4
Gases - Industrial Cylinders for	295/44; 60/4
Gassing in Depth Charges	262/4
General Instructions - Food rationing and food economy	28/4
Message of "H" and "I" Series remaining in force	265/4
Generators - Diesel - Exhaust Pipes	140/4
- Stiffening of Seatings of Kelly and Lewis Steamdriven - A.M.S. vessels - Alterations and additions	428/4
Good Conduct Badges - Counting of previous service toward award Service Badges - R.A.N.R. - Deprivation and Restoration	†104/4
Government Stores - Misappropriation - Reports to Civil Police	589/4
Gowrie Scholarships	61/4
Grant of full and modified "Qualified Officer" status in the R.A.N.	72/4
Grants-in-Aid and Percentage Charge - Orchestral Band Instruments	52/4
Gratuities - Outfit - on Change of Class of Uniform	74, 152/4
Gratuitous Issues of Uniform and Clothing to British and Allied Services	197/4
Gratuity, Outfit - Lieutenant (Emergency or Retired) - Payable on promotion from commissioned warrant officer or warrant officer	250/4
Greatcoats for Naval Chaplains - Supply of	661/4
Grids for Eye Shooting Sights, for close Range Weapons - Increased Allowance	211/4
Guard Rail Stanchions on Forecastle - A.M.S. Vessels	660/4
Gun Armament Material and Ammunition - Failure of	150/4
Mountings - Test of Recoil Cylinder Liquid	†166/4
Trials - Procedure	144/4
- Reports - Elevating and Training Efforts	192/4
- 4-inch Gunmounting Marks XXIII and XXIII*	38/4
Gunmountings - 4-inch Marks XXIII and XXIII* - Filling Recoil Cylinders	528/4
Gunnery Communications - A.M.S. Vessels	†57/4
Equipment - D.E.M.S. - Painting of	143/4
Trials	†7/44; †40/4
Practices in Small Ships	350/4
Ratings - D.E.M.S. - Badges	†78/4
	252/4
	95, 358/4

† Denotes C.C.N.O.

Subject

G - contd.

C.N.O. or
C.C.N.O. No.

Guns and Gun Mountings - Bofors - Care and Maintenance	103/44
- 40 m.m. - Foresights	548/44
- Mk.IIIA - Modification of Earlier Pattern Pedestals	228/45
- Lewis and Savage Lewis .505 in. - Magazines 97 Rounds Fitted with Lengthened Catch	29/45
- Machine .505" Bren and .505" Vickers G.O. - Modification to Mag- azines and Repair Magazine Main Springs	594/44
Mark I - Springs Return - Exchange of	49/45
- Lewis - Conversion of Mk.IV Sights (100 Knots) to Mk.V (200 Knots) and Fitting of Mk.III Butt Plate	552/44; 211/45
- Vickers G.O. - Modifica- tions to prevent wrong assembly on Single A.A. Mountings - Butts for	595/44
Oerlikon	477/44
- Oerlikon - Mark II and IV - Collapse of Barrel Springs Mk.I	595/44
- 20 m.m. - Adaptor for cleaning rods - introduction	550/44
- Locking of Barrels	505/44
- Spares Appurtenances, etc. - Basic Sets	179, 549/44
- O.Q.F., 4 inch XVI* - Extractors	550/44
- Q.F. 3 in. 20 cwt. Mk.I, IB - IE Pins Axis Breech Mechanism Lever Catch Mk.I to be replaced by Mk.II	†11/44
40 m.m. - Method of Testing Blow of Striker	351/44
2 pdr. Mk.XIV Guns and 40 m.m. Rolls Royce Mountings - Disposal of	306/44
- Report of Stock and Transactions	20/45
- Single 40 m.m. Bofors Mk.IIIA - Supply of Sights Correctional 40 m.m. A.A. Mtgs. Mk.V (Aust)	445/44
- 2-pdr. Mk.XIV Replacement in "B" Type M.Ls. by 3-pdr. Mk.V and 2-pdr. Mk.VII*	37, 130/45
- 4-in. XIX, Re-arming with, on H.A.L.A. XXIII* Mounting - H.M.A. Ships	442/44
- 4-in. Mark XXIII and XXIII*	280/44
- Elevation Buffer Stop - Replacement of Spring by Distance Piece	208, 592/44
- Firing Gear - Modification to Catch Piece	372/44
- Lower Elevation Gear Box - Fitt- ing of Leather Waaher	374/44
	573/44

† Denotes C.C.N.O.

Subject

C.N.O. or
C.C.N.O. No.

G - contd.

Guns and Gun Mountings - 4-in. Mark XXIII and XXIII* - contd.	
- Lubrication of Centre Pivot ..	566,637/44
Gymnastic Shoes for W.R.A.N.S...	19/44
Gyro Compass (Brown Type "A") - Replacement of 2 mfd. condensers in transmission Spark Quench Circuit ..	590/44
Equipment, Mark XIV - H.M.A. Ships ..	†50/45
Repeats for Radar in A.M.S. Vessels ..	†41/45
- Sperry Mod. I Mk. XIV - Condensers - Follow up Circuit	379/44
- Incorrect filling of transmitter connecting cables ..	314/44
- Mercury Ballistic Caps ..	378/44
- Oiling of Upper Vertical Guide Bearing ..	376/44
- Repeater Bezel Screws ..	377/44
Gun Sights - Housing Oerlikon Guns fitted with Mk. XIV ..	254/44
- Mk. IV - Fitting to Mk. VIIA Oerlikon Mountings	†163/44
- Wiring changes to provide standby conditions ..	†11/45
- U.S. Mk. XIV ..	†233/44

H

"H" and "I" Series - General Message of - remaining in force ..	140/44
Hailing equipment - A.M.S. Vessels - Alteration and Addition Item C.A.F.O. 3963/43 ..	†108/44
Half-yearly Reports on A/S Equipment - Record of Personnel ..	†148/44
Hall Scott Defender Engine(s) Fuel ..	†77/45
Oil Cooler Cores ..	206/45
Handbook on Lookouts and Service Optical Instruments - B.R. 797 (1943) - Amendments ..	340/44
Hand-up Chutes for 4" Ammunition ..	†180/44
Haversacks - Painting of - Anti Gas Respirator ..	382/44
Hawsers for A.M.S. Vessels ..	168/45
Haze Screens - R.A.N. Pattern - Modification ..	154/44
Health - Prevention of disease and maintenance of health in tropical climates ..	539/44
Heat Treatment of Shuttle Valves of Reciprocating Pumps ..	107/44
Hedgehog Projectiles - Landing of ..	239/45
Heliographs, Binoculars, Telescopes and Watches - Muster of ..	397/44
Helmets, Steel (R.A.C.) Mk. I - Introduction ..	97/45
Higher Educational Test - Results - October, 1943 ..	156,248/44
- April, 1944 ..	439/44
- October 1944 ..	25/45
History of the War - Naval Medical ..	73/44
Sheets - Depth Charge Pistol - Details required ..	145/44
- Form O.426 ..	94/44
H.M.A. Frigates and H.M.A.S. "Orara" and "Kybra" ..	†183/44
H.D.M.L. 1161 - Paying off ..	†50/44
1322 - Commissioning ..	†18/44
1323 - Commissioning ..	†19/44

† Denotes C.C.N.O.

Subject

C.N.O. or
C.C.N.O. No.

H - contd.

H.M.A. H.D.M.L. contd.	
1324 - Commissioning ..	†137/44
1326 - Commissioning ..	†23/44
1328 - Commissioning ..	14/45
1329 - Commissioning ..	†139/44
1338 - Commissioning ..	†129/44
1339 - Commissioning ..	†147,†172/44
1340 - Commissioning ..	†110/44
1341 - Commissioning ..	†278/44
1342 - Commissioning ..	†173/44
1343 - Commissioning ..	†227/44
1346 - Commissioning ..	†10/45
1347 - Commissioning ..	†2/45
1352 - Commissioning ..	†109/44
1355 - Commissioning ..	†256/44
1354 - Commissioning ..	†285/44
1357 - Commissioning ..	†255/44
1358 - Commissioning ..	†244/44
1359 - Commissioning ..	†220/44
825 - Commissioning ..	†29/44
826 - Commissioning ..	†4/44
827 - Commissioning ..	†91/44
- Paying Off ..	†269/44
H.D.M.Ls. ex U.S.A. - Fitting of Twin Vickers .303" Mountings - Alterations and Additions ..	453/44
M.L.428 - Commissioning ..	†68/45
430 - Paying Off ..	†187/44
431 - Commissioning ..	†48/45
Radar Training Establishment ..	38/45
Ships - Additional Officers borne for Training ..	92/45
- Aircraft Operating from - Emergency Rations for and Establishments - Mail ..	67/44
- Photographic Material for use in ..	8/44
- Reduction in Kits in ..	241/44
- Attached to Eastern Fleet - Service Certificates and Pay Accounts ..	57,440/44
- Coal for - Procedure governing supplies ..	32/44
- Code and Cypher Machines - Installation in ..	†112/44
- Emergency Rations for Aircraft Operating from ..	67,445/44
- Establishment of Chart Folios ..	†190/44
- Firefighting in - Alteration and Addition - A.F.O. 5393/43 ..	†97/44
- Fitted with Mk. XIV Gyro Compass Equipment ..	†50/45
- Fitting of Additional Armament in ..	†46/44
- Fuzes, Time, on Board - Annual Percentage landing in Wartime ..	253/44
In Harbour - Anti-Sabotage Measures by ..	†76/44
- Maintenance of Upper Deck Fitting ..	178/44
- Provisions supplied to, by U.S. Navy Supply Ships and Depots ..	133/45
- Radar Stores for ..	131/45
- Re-arming with 4" XIX Guns on H.A.IA XXIII* Mounting ..	260/44
- Reports of Proceedings ..	†97/45
- Signatures of Issuing Officers on Travelling Warrants ..	674/44
- Sun Reflecting Device for ..	33/44
- Supply of Steel Furniture to ..	536/44
- Ventilation of ..	454/44

† Denotes C.C.N.O.

Subject

H - contd.

C.N.O. or
C.C.N.O. No.

H.M.A. Ships - contd.

Subject	C.N.O. or C.C.N.O. No.
- Zinc Sheets and Underwater Protection of Ships and Fittings	517/4
Shore Establishments - Name Ships	†590/4
Store Carriers - Loading of	†95/4
H.M.A.S. "Air Bird" - Commissioning	†60/4
"Air Chief" - Commissioning	†186/4
"Air Clan" - Commissioning	†286/4
"Air Cloud" - Commissioning	†246/4
"Air Faith" - Commissioning	†25/4
"Air Hope" - Commissioning	†29/4
"Air Host" - Commissioning	†245/4
- Renaming	†70/4
"Air Master" - Commissioning	†201/4
"Air Mercy" - Commissioning	†39/4
"Air Mist" - Commissioning	†216/4
"Air Rest" - Commissioning	†218/4
"Air Sailor" - Commissioning	†254/4
"Air Save" - Commissioning	†217/4
"Air Sense" - Commissioning	†42/4
"Air Speed" - Commissioning	†38/4
"Air Spray" - Commissioning	†27/4
"Air Trail" - Commissioning	†28/4
"Air View" - Commissioning	†265/4
"Air Watch" - Commissioning	†274/4
"Air Wave" - Commissioning	†215/4
- Renaming	†89/4
"Adelaide" - Commissioning	†84/4
- Paying off	†45/4
"Alatna" - Commissioning	†28/4
"Alexander Thompson" - Paying Off	†287/4
"Alfie Cam" - Paying off	†158/4
"Allenwood" - Paying off	†249/4
"Allura" - Commissioning	†111/4
"Anaconda" - Commissioning	†85/4
"Arcadia" - Commissioning	†6/4
"Arista" - Paying off	†92/4
"Barcoo" - Commissioning	†17/4
"Bataan" - Commissioning	†92/4
"Bermagui" - Re-commissioning	†5/4
"Black Snake" - Commissioning	†3/4
"Bombo" - Commissioning	†27/4
"Bonthorpe" - Paying off	35/4
"Boonooro" - Paying off	†75/4
"Burdekin" - Commissioning	†178/4
"Burrabra" - Paying off	†127/4
"Caroo" - Paying off	†6/4
"Carpentaria" - Commissioning	85, 101/4
"Emilea" - Paying off	†86/4
"Geelong" - Paying off	†237/4
"Gippsland" - Paying off	†128/4
"Goonabee" - Paying off	†156/4
"Gunbar" - Re-commissioning	†132/4
"Harman" - Commissioning	188/4
"Hawkesbury" - Commissioning	†154/4
"Hoona" - Paying off	†185/4

† Denotes C.C.N.O.

Subject

H - contd.

C.N.O. or
C.C.N.O. No.

H.M.A.S. - contd.

"Jester" - Paying off	†196/44
"Jon Jim" - Paying off	†279/44
"June" - Commissioning	†76/44
"Kanimbla" - Commissioning	†171/44
"Karina" - Commissioning	†275/44
"Kiama" - Commissioning	†22/44
"King Bay" - Paying off	†54/44
"Krait" - Commissioning	†77/44
"Kuranda"	236/44
"Kweena" - Paying off	†80/44
"Laohlan" - Commissioning	†26/45
"Larrakia" - Paying off	†49/44
"Larus" - Commissioning	†290/44
"Limicoola" - Commissioning	†226/44
"Limosa" - Commissioning	†253/44
"Lorne" - Renaming	†85/45
"Lussair" - Commissioning	100/45
"Madang" - Commissioning	228/44
"Marlean" - Paying off	†254/44
"Marcoma" - Paying off	†94/44
"Medea" - Paying off	†86/45
"Mercedes" - Paying off	†87/45
"Metafele" - Paying off	†171/44
"Narani" - Paying off	†192/44
"Nepean" - Paying off	†266/44
"Orara" - Paying off	†7/45
"Pandion" - Commissioning	†191/44
"Parkes" - Commissioning	†124/44
"Pedare" - paying off	†114/44
"Pioneer" - Paying off	†150/44
"Rathane" - Paying off	†93/44
"Resurgum" - Paying off	†159/44
"River Snake" - Commissioning	†34/45
"Rushcutter" - Organisation	55/45
"Sleuth" - Renaming	109/45
"Sprightly" - Commissioning	†39/44
"Steady Hour" - Paying off	†49/45
"Sterna" - Commissioning	†95/45
"Strahan" - Commissioning	†59/44
"Summit" - Paying off	†160/44
"Sundowner" - Paying off	†157/44
"Sylph" - Paying off	†95/44
"Tasma" - Paying off	†45/44
"Terka" - Paying off	†81/45
"Three Cheers" - Commissioning	†247/44
"Tiger Snake" - Commissioning	†202/44
"Tongkol" - Paying off	†151/44
"Topsy A" - Paying off	†101/44
"Tringa" - Commissioning	†53/45
"Valangen" - Paying off	†85/44
"Vigilant" - Commissioning	†90/44
- Re-naming	285/44
"Viking" - Re-naming	286/44
"Wangola" - Paying off	†174/44
"Westralia" - Commissioning	†3/44
"Westwind" - Paying off	†268/44
"Watson" - Commissioning	110/45

† Denotes C.C.N.O.

Subject	C.N.O. or C.C.N.O. No.
H - contd.	
H.M.A.S. - oontd.	
"Whang Pu"	†84/44
"Wongalere" - Paying off	†125/44
- Re-commissioning	†155/44
"Yunnan" - Commissioning	†214/44
H.M.A. Submarine "K9" - Paying off	†67/44
Victualling Depots	342/44
H.M.S. "Beaconsfield" - Commissioning	†57/45
"Furieux" - Commissioning	64/45
"Golden Hind"	†252/44
"Nabaron" - Commissioning	†15/45
"Nabbington" - Commissioning	†5/45
"Nabthorpe" - Commissioning	†4/45
H.M. Ships transferred to R.A.N. for Manning - Arrangements in respect of the Agreement between the U.K. and the Australian Governments	†51,227/44
Hoist Pusher 8-in.	94/45
Homing Torpedo - Acoustic - Counter Measures to - F.X.R. Gear	†120/44
Honours, Awards and Decorations - R.A.N. Personnel	200,288,515,679/44;146/45
Hooks Sling Universal and Slings Rifle - Use	62/45
Hose Tubing - Canvas - Prolonging Life	92/44
Hospitality for Personnel on leave at Sydney - Command Amenities Liaison Officer	177/45
Hospitals - Australian Service - R.N. Personnel	157/45
- Private - Approved - Rates of treatment in - for Naval Naval Officers	203/45
- R.A.N. - Treatment of Netherlands Forces	205/45
Housing Cerlikon Guns fitted with Mk.XIV Gyro Sights	254/44
Hydrometers - Boiler Water - Sensitive Glass, Pattern 37A	187/45
Hygiene and Sanitation - General - including the prevention of Malaria - Preservation of Health	269/44

I

Ian Macdonald Memorial Prize	365/44;192/45
I.F.F. Equipment - Return of Type A.B.K. sets to Store on replacement by Radar Type 253	†96/44
Igniters, Torpedo, Mark XI - Lot No.144, Filled S.W.Y.N. 9/41 - Withdrawal	64/44
No.217, Filled B.R.12/41 - Withdrawal	155/44
Illuminating Rockets 3½ lb. - Prematures	40/44
Illumination of Sight Dials - 4" Mark XXIII* Mountings	327/44
Income Tax Returns	453/44
India Rubber Washers for Hose Couplings - Use of correct patterns - United Kingdom Air Mail	534/44
Indicator Loop Identification Signal Apparatus	†238/44
Industrial Gases - Cylinders for	262/44
Infantry, Landing Ships - Administration	†117/44
Inflatable Lifebelts - Torches and Sleeves for - Life Saving Equipment	†126,212/44
Influenza Virus Vaccine - Type "A"	153/45

† Denotes C.C.N.O.

Subject	C.N.O. or C.C.N.O. No.
I - contd.	
Inglefield Clips and Unserviceable Flags - Return to Store	69/44
Pattern 100 - Defence in manufacture	671/44
Injuries and Wounds by Enemy Action	550/44
Inoculation against cholera	149/44
Inspection - Annual - Explosives ex H.M.A. Ships	111/44;50/45
of Rifles	551/44
Installations - Asdic - Types 144/5 - Training of Personnel	†70/44
Instructors - Visual Training	55/45
Interference - R/T - A/S Equipment in M.Ls.	†61/44
with W/T and R/T Reception - Radar Type A 286 P/Q	†48/44
Introduction of Cartridges M.L.9.5-in. D.C.T. Cordite H.S.C.T.134 - D55, 4-oz. O-D.R.M.S. Mk.XII	†75/44
Invalids - Use of Army Medical facilities in transfer of	641/44
Irregular wearing of Class III Uniform - Acting Petty Officers	106/44
Issue A.C.B. 247 (R)	83/44
of Confidential Navy Orders	†1/44;†1/45
Free Kits to Ratings on entry	154/44
Materials - Repayment - Uniform and Clothing Supplies	171/44
Mess Gear and Blankets to Personnel Travelling	170,552/44;234/45
Navy Orders	1/44;1/45

J

Journals - Medical Officers	527/44
Junior Writer and Supply Ratings - Typewriting experience	176/44

K

Kelly and Lewis steam-driven Generators - Stiffening of Seatings - Alteration and Addition - A.M.S. vessels	†104/44
Keys of Safes and Chests in small Ships	†52/44
Khaki Drill Service Dress for Officers	263/45
King's Regulations and Admiralty Instructions	108/45
- Reprint	387/44
Kit - Authorized - Uniform and Clothing - W.R.A.N.S.	20,55/44;137/45
Lockers - Additional - A.M.S. vessels	†41/44
- Medical First Aid	70/44
of Ratings drafted to Darwin, Thursday Island, New Guinea or other Forward Areas in the South West Pacific	263/44
- Reduction of - in H.M.A. Ships and Shore Establishments	241/44
- Variations in - Small Blue Kit Bags and Suit Cases	234/44
Kites and Drogues - for use as Anti-Aircraft Targets - Discontinuance of Supply	146/44

† Denotes C.C.N.O.

Subject

C.N.O. or
C.C.N.O. No.

L

Landing Cordite	80/44
of Hedgehog Projectiles	239/45
Ships - Administration	208/44
Lanterns - Plywood - Radar Types 271/3, A.272 - Maintenance	†38/44
Launches - Motor - Engine Register	162/44
Leading Stoker Courses	516/44
Leather Sea Boots - Economy	80/44
Leave and Relief of Personnel - Northern Areas	218/45
Concession and Other Railway Travelling Warrants	448/44
Ledger and Pay Accounts - H.M.A. Ships	467/44
Pages and Register Forms (Naval Storekeeping)	254/45
Sheets - Consumable Naval Store - Amendment of Form A.S.151	246/44
Legal Assistance to members of the Forces - Distribution of Booklet	73/45
Service Bureaux - Commonwealth	629/44
Letters - Found amongst effects of deceased personnel	36/44
Lewis Guns .503-in. - Stripped - Allowances	580/44
Liaison between Naval and Air Force Officers engaged on convoy	
protection - Pay arrangements	141/44
Library Books - Purchase Price Limit	145/45
Lieutenant Commander(s) R.A.N. - Examination for the rank of	182/45
- Naval Reserves - Promotion of Naval	
Reserve Officers to rank or relative	607/44;59,141/45
rank of	
Lieutenant (Emergency or Retired List) - Outfit Gratuity payable	211/44
on promotion from Commissioned Warrant Officer or Warrant Officer	
Life Lines - Firefighting Equipment	58/45
Lifesaving Equipment - Flotants	132/45
- Sleeves and Torches for Inflatable	
Lifebelts	126,212/44
Rafts - Release of	468/44
Lighters - Ammunition - Loading for Ocean Passages	†199/44
Linen - Bed - Clothes Rationing	183/44
Liquor - Supply to H.M.A. Ships and Establishments by Australian	
Army Canteens Service	538/44
Listening Watch - Modification for - Radar Types A.296 P/Q	†113/44
"L.L." Cable Drums - Stiffening of Hand Winding Gear - A.M.S. Vessels	545/44
Sweep Reel - Failure of Hand Winding Gear - A.M.S. Vessels	359/44
57/5 Cells for L.L.Sweeps - A.M.S. Vessels	†8/44
Loading of H.M.A. Store Carriers	†95/45
Loan Issue of Brown Dungaree Combination Suits to Officers	112/44
Local Secret Confidential and O.U.Books - Corrections to	†170,†182,†189,†200,
.. .. .	†213,†235,†285/44;†22,†47,†67,†91/45
Lookers for Damage Control Stores	506/44
Fire Fighting and Action Repair Materials" - A.M.S.	
Vessels - Alterations and Additions	†65/44
- Kit - Additional - A.M.S. Vessels	†41/44
Locking of Barrels - 20 m.m. Oerlikon Guns	348/44
Log(s) - Cypher and Signal - Disposal of	†44/44
London Correspondence	604/44
Loop Repair Vessels - Naming of	†197/44
Loss of Pistols, Revolver	18/44
Tools - Compensation for	184/44
Ventilating Fan	66/44
Low Power Batteries - Increased Capacity	†276/44
- Mounting on Resilient Mountings in order	
to reduce effects of shock	†232/44
Supply System - Frigates	†18/45
W/T-R/T Installation Type R.C.8	†30/45
† Denotes C.C.N.O.	

Subject

C.N.O. or
C.C.N.O. No.

L - contd.

Lubricating Oil for H.M.A. Ships "Kybra", "Wilcannia" and	109/44
"Reserve"	603/44
Lubrication Oils and Greases - Standardization and Purchase	
M	
Machine Guns - Lewis .503" - Conversion of Mk.IV Sights (100 knots)	
to Mk.V (200 knots) and fitting of Mk.III Butt	552/44
Plate	611,685/44
Tools - Co-ordinate use in Australia between the services	†24/44
Machinery - Coding - Transport of	
- Machine tools, etc. supplied for Naval Workshops -	108,584/44
Accounting for	22/44
- Office - Annual Census	666/44;
Spares - Organization for the Provision, Storing, etc.	176,216/45
- Spare Propellers and Shafts for H.D.M.Ls. etc.-	193/45
Authorized Establishment	
Made-to-Measure Jackets and Skirts - W.R.A.N.S. Ratings - Contracts	406/44
for Supply of	405/44
Uniforms - Ratings - Contracts for Supply of	691/44;169/45
Magazine Logs - Rendering	276/44
Magazines - unloading	†7/45
Mail Address - R.A.N. Beach Unit	44/45
from H.M.A. Ships and Naval Establishments	525/44
in H.M.A. Ships - Transport of	437/44
Received at Milne Bay - Damage to	165/44
Maintenance and care of Bofors Guns	
Bases on Shore and Repair Ships - Distribution of	542/44
Personnel	89/44
of Cordite Records on Board H.M.A. Ships	178/44
Fittings - Upper Deck - H.M.A. Ships	†58/44
Radar Types 271/3 A.272 Plywood Lanterns	118/44
Malaria - Control - Drafting of Personnel	
- Including the prevention of - Preservation of health -	269/44
General hygiene and sanitation	15/44
- Supply of Stores for measures for prevention and control	240/44
- With Atebrin - Suppressive treatment (Prophylaxis) for	54/44
Marking of Cartridges with Sub-Lot XJ - M.Ls.	†98/44
Packages containing Asdic Stores	216/44
Markings - Case - Shipment of Mining Stores	76/45
Marriage and Child Allowance - Sterling Payments	457/44
Mats and Table Cloths	368/44;119/45
Meals for R.A.N. personnel travelling by troop train	526/44
Mechanics - Ordnance and Electrical	512/44
Medal Ribbons - Wearing with Tropical Dress	212/45
Medical and Dental Stores - Supply in the New Guinea Area	†272/44
Facilities in the New Guinea Area - R.A.N.	
Officers - R.A.N.R. and R.A.N.V.R. -	621/44
Qualified Status	
Attendance of W.R.A.N.S. at Melbourne by a female	572/44
medical practitioner	120/44
Examination prior to draft	641/44
Facilities - use of Army, in transfer of invalids	
† Denotes C.C.N.O.	

Subject	C.N.O. or C.C.N.O. No.
M - contd.	
Medical - contd.	
History of the War - Naval	73/44
Observation or Treatment not requiring hospitalization - Despatch of personnel to Sydney for ..	258/44
Officer - Naval - Port Division - Appointment of ..	622/44
- Principal - New Guinea - Duties of ..	18/45
Officers' Journals	527/44
Requests for Demobilization ..	19/45
Practitioners - Private - Mileage allowance ..	5/45
Status of Personnel recommended to be invalidated - Introduction of Form A.M.301Z	347/44
Store(s) Account for Scale "C" Medical Stores - Form 177G	222/44
- Scale Base Depot Sick Bays Amendments No.1 and No.2	400/44
"C" Amendments No.1 and No.2	401/44
"E" and Coxwains set of First Aid Instruc- tions - Booklet - 1944	581/44
Service Afloat - Amendments Nos. 1 and 2	598/44
"Sick Quarter" Amendments Nos. 1 and 2 ..	401/44
Members of the W.R.A.N.S. discharged on account of pregnancy	†118/44
Memorandum - Official - Prices of clothing, etc. maintained for issue on repayment to ship's companies	31/44
Memorial Prizes and Testimonials	25/44
Mental Disorder - Certification of members of R.A.N. suffering from Hospitals or Receiving Houses - Admission of Naval per- sonnel to	546/44
Mercuroous Grease - Not to be used with Brasses and Bronzes ..	160/44
Mess Gear and Blankets - Issue of, to personnel travelling ..	161/45
Traps - Officers' - Replacement allowances - applicable for 1944-45	254/45
Utensils for Chief Petty Officers', Petty Officers' and Men's Messes - replacement allowances - Applicable for 1944-45	657/44
Messing - General - in small ships - installation	665/44
- Supply of Stainless Steel Trays	626/44
Microphotographic X-ray Examinations ..	175/45
Mileage Allowance - Private Medical Practitioners ..	529/44
Military Detention Barracks - Uniform and Clothing for Ratings in	5/45
Mine(s) Rendered Safe - Disposal	356/44
Rendering Safe - Employment of personnel other than Officers	252/44
Washed Ashore - Rendering of Reports	251/44
Minesweeping - A.M.S. Vessels fitted for - alteration and addition - Spur for additional Signal Halliards ..	45/44
- Use of Iron Sinks ..	†118/44
Mining Stores - Shipment of - Case Markings ..	†270/44
Minol filled depth charges Mk.VII - VII*	59/45
Minor War Vessels - Stowage for firefighting and action repair materials	106/44
Taken up for War Service ..	†179/44
Misappropriation of Government Stores - Reports to civil police	485/44
M.Ls. - Repositioning of depth charge chutes ..	72/44
Modification(s) for Listening Watch - Radar Type A.286 P/Q	†152/44
- Guns Machine Bren .503" - Boxes Magazine Mk.I ..	†115/44
- Procedure for Accounting for Naval Stores incor- porated in W/T, A/S Radar, etc. sets ..	568/44
R.A.N. pattern haze screens ..	139/44
to Aerial Training System A/SI and A/S3 - Radar Types A.272, A.286 P/Q ..	134/44
	†81/44
† Denotes C.C.N.O.	

Subject	C.N.O. No. C.C.N.O. No.
M - contd.	
Modification(s) - contd.	
to Bridge Chart Table - Escort Vessels fitted with Radar ..	†154/44
Catch Piece - Firing Gear - Gun Mounting 4" Mk.XXIII and XXIII*	374/44
Evaporator Systems - H.M.A.Frigates ..	150/44
and A.M.S. Vessels	†68/44
Firemain and Station 54 - A.M.S. Vessels ..	370/44
Magazines and Repair Magazine Main Springs - Guns Machine .503" Bren and .303" in Vickers G.O. ..	394/44
to prevent wrong assembly - Guns Machine .303" in Vickers G.O. ..	395/44
O.Q.F. 4.7" Mk.XII, XII* and XII B Breech Mechanisms ..	579/44
- Method of securing depth charge chute to dock Motor Launches ..	†26/44
- Steam Driven Boiler Room fans ..	195/44
- Type AT5/AR8 W/T - R/T set ..	†80/44
Monthly Ammunition Expenditure - Returns ..	224,†271/44
Morse Operators - Automatic - Visual Signallers, Coders and T/P - W.R.A.N.S. advancement ..	204/44
Mosquito Nets ..	215/44
Motor Launches - Engine Register ..	162/44
- Fairmile - Type "B" - slipping of ..	12/44
- Prevention of fire in ..	124/44
- Replacements for Electrical Equipment in ..	362/44
- Repositioning of D.C. Chutes ..	†184/44
- Telephones on Bridge ..	417/44
Transport Forms ..	49/44
Vehicles - Naval - accidents ..	56/44
- Rear Vision Mirrors ..	165/45
Mountings - 4" Mk.XXIII and XXIII* - Care in Assembly of Roller Units ..	610/44
Movements of personnel - reporting ..	256/45
Musical Instruments - Bugles ..	509/44
N	
Names - Allocation to Air Sea Rescue Vessels ..	412/44
Name ships - H.M.A. Shore Establishments ..	390/44
Naming of A/S. and Radar Maintenance Vessels ..	†198/44
Special Craft for S.R.D. ..	†250/44
75 ft. Loop Repair Vessels ..	†197/44
National Security Regulations -	
- Delegation of Power and Order made thereunder ..	179/45
- Mobilization of Vessels Order (No.3) ..	485/44
- Navigation and Anchor Lights Order (No.5) ..	343/44
(No.4) ..	425/44
Naval Armament and Torpedo Store Account - Errors and Omissions	612/44
Depot, Darwin ..	†146/44
Store Accounts - H.M.A.Ships, etc.- Consumable Stores	385/44
- in D.E.M.S.- Accounting procedure ..	515,615/44
† Denotes C.C.N.O.	

Subject	C.N.O. or C.C.N.O. No.
N - contd.	
Naval - contd.	
Base, Darwin - Organization	255/45
Board of Administration	541/44
- Business Member	105/44
Canteens and Messes - Chocolates and Confectionary for	158/44
Censurship	25,98,177,651/44; 215,242/45
Medical History of the War	73/44
Military and Air Force Club, Adelaide	178/45
Officer(s)-in-Charge - Brisbane - Correspondence on Naval	
Armament Store matters	174/44
- Broome	498/44
- New Guinea - Transfer of Headquarters	424/44
Personnel - Admission to mental hospitals or receiving houses	160/44
- Applications from, for discharge	205/44
- Delayed in transit and/or awaiting onward	
passage by rail on completion of leave	112/45
- Food coupons	266/44
- Repatriated - liability for further active service	206/44
Reserve Officers - Confidential reports on	257/44
- Naval Watchkeeping Certificates	256,319/44;2/45
- Promotion and confirmation of	301/44
- Qualified status for officers of	
Commander's rank	111/45
Storekeeping arrangements and accounts - Responsibility	
for Inspection	99/45
Store(s) - Accounting - Procedure in Frigates	244/44
- Consumable - Ledger Sheets - Amendment of Form	
A.S.151	246/44
- Depot, Melbourne - Correspondence for	35/45
- Lost by accident, neglect or theft - procedure	402/44
- R.A.N. Establishments of	625/44
- Returned to Bases from H.M.A. Ships and Services -	
Disposal	186/45
Navigation Courses	59/44
Navigation Courses to qualify for command of an A.M.S. - R.A.N.V.R.	
Officers	228/44
Navy, Army, Air Force Club of Victoria - Honorary Membership	609/44
Netherlands - Expenditure on behalf of - classification	187/44
Forces - Members of, treated in R.A.N. Hospitals or	
sick quarters	205/45
Nets, mosquito	212/44
New Guinea - Period of Shore Service	105/45
Next-of-Kin particulars - insertion in September Quarter Ledger	476/44
Night Vision - Classification by A.R.L. Adaptometer (Mark III)	345/44
Non-substantive rates - Recommendation for	367/44;248/45
Northern Bases - Ammunition supply to	145/44
- Personnel serving at	150/44
Operational Bases - Stores consigned by sea or air	
freight to	167/44
Nursing Service - R.A.N. - Administration	47/45
- Supply of Nurses indoor made-to-measure	
dresses	255/45

† Denotes C.C.N.O.

Subject	C.N.O. No. C.C.N.O. No.
O	
Oerlikon Guns and Mountings	593/44
- Housing - fitted with Mk.XIV Gyro Sights	254/44
Machine Guns - 20 m.m. - Spring Barrel Mk.II	585/44
20 m.m. Guns - Adaptor for American Rods - Cleaning and	
Ejecting - Introduction	505/44
H.E.Lot H.N.C. 13 - Withdrawal	m309/44
N.F.E.404 - Ammunition - Withdrawal	510/44
T.P.C.746 - Ammunition - Withdrawal	487/44
Tracer Lot N.F.H.2257F - Ammunition -	
Withdrawal	507/44
10B/45 - Ammunition -	
Withdrawal	508/44
- Locking of Barrels	549,465/44
- Mks.II and IV - Collapse of Barrel Springs Mk.I	350/44
- Mk.IIIA - Replacement by Mk.VIIA - A.M.S. Vessels	227/45
- One Man Cocking Device	261,586/44
- Spares, Appurtenances, etc. - Basic Sets	530/44
Offences committed by ratings on passage to and before joining	
H.M.A.S. "Melville"	85/44
Office Machinery - Annual Census	22/44
Machines - Method of Packing	168/44
Officers - Additional - borne for Training in H.M.A. Ships	92/45
- Cap Badges	257/45
- Carrying out duties of gunners - working suits	484/44
- Confidential reports on	427/44
- Dress	150/44
- Executive - Radar Courses for	115/44
- Introduction of G.C.O.* and Gunner Substitute	183/45
- Khaki Drill Service Dress	265/45
- Naval Reserve - Confidential reports on	257/44
- Naval Watchkeeping Certificates	256,319/44
- Prisoners of War - Promotion	426/44
- Promoted direct from warrant rank	11/45
- Transfer - in charge of Naval Stores on Permanent Loan	54/45
Official Memorandum - Prices of clothing, etc. maintained for	
issue on repayment to Ships' Companies - Amendment	31/44
Oil Fuel	196/45
- Naval Stocks in Australia	115/44
- Lubricating - H.M.A. Ships "Kybra", "Wilcannia" and "Reserve"	109/44
Oiling at Sea - Special arrangements for H.M.A. Frigates -	
A.F.O. 4159/44	159/45
Oilskin Anti-Gas Clothing - Upkeep and Repair	21/44
Clothing and Rubber Sea Boots - Storage of	245/44
Ointment and Anti-Gas Eye Shields - Revision of Allowances	209/44
Operators - Teleprinter	62,271/44
Optical Instruments - Service and Lookout - Handbook on -	
B.R.797 - "1943" - Amendments	540/44
O.Q.F. 4-inch Mark XVI* Gun - Extractors	111/44
40 m.m. Bofors - Locking of Screws, Securing Bracket	
Supporting Buffer - Fitting of Shock-	
proof washers	466/44
- Mk.I of Australian Manufacture - Springs	
Striker Breech Block - Examination	567/44
- Mk.I* - Springs Striker Inner and Outer	222/45
- Series Inspection	67/45
Orchestral Bank Instruments - Percentage charge and grants-in-aid	197/44

† Denotes C.C.N.O.

Subject

O - contd.

	C.N.O. or C.C.N.O. No.
Orders under National Security Regulations - Immobilization of Vessels Order (No.3)	483/44
Navigation and Anchor Lights Order (No.3)	343/44
(No.4)	423/44
Wireless Stations Control Order - Revocation of certain directions thereunder	80/44
Ordnance and Electrical Mechanics	631/44
Branches	82/44
- B.L. - Care of Obturator Seatings and Pads	683/44
- Q.F. 40 m.m. Bofors - E.F.C. Valves	578/44
- Liquid in Recoil Buffers	375/44
Oscillator Unit - Local - Radar Set A272 Mark I	†79/44
Outfit Gratuities on change of class of uniform	250/44
- Payable on promotion from commissioned Warrant Officer or Warrant Officer - Lieutenant (Emergency or Retired List)	211/44
Oxy-Acetylene Welding and Cutting Equipment	436/44

P

P.A.C. and Snowflake Rockets - Precautions when carrying out practices or demonstrations	52/44
Projectors - A.M.S.	†151/44
Rocket failures	6/44
Rockets - A.M.S. Vessels	88/44
Packages containing Asdic Stores - marking	†98/44
Packing and Transport of Enemy War Material and Explosives Stores of office machines - method	†13/45
Rings - Boiler Water Gauge Glass - Pattern 40	168/44
Paint Dry colour - Issue of shading paste in lieu	21/45
- Types to be used for interior painting - Reduction of fire and smoke risks in H.M.A. Ships	44/45
Painting D.E.M.S. Gunnery Equipment	369/44
of Haversacks - Anti-Gas Respirators	330/44
382/44	
Passages to Australia for dependants of members of the Forces who have married abroad	392,576/44
Passports for wives and fiancées - service personnel overseas	157/44
Pattern 474 Stretcher Cots - Supply	243/44
1937 - Web Equipment	137/44
Pay Accounts and Service Certificates of H.M.A. Ships attached to Eastern Fleet	57,440/44
Ship's Ledger	467/44
Arrangements - Liaison between Naval and Air Force Officers	141/44
- Deferred - Mobilized personnel	27/44
- Special rate for Warrant Officers	361/44
Paying Off - H.M.A.S. - See H.M.A.S.	
Paymaster Lieutenant-Commander - Examination for rank of	202/44
Payment of Contractors' claims in connection with funerals	230/44
Fares of relatives attending funerals of deceased service personnel	274/44
Penicillin	355/44
- Care and custody of	497/44
- Casualty Label Army Form A.A.F. D.113	87/45

† Denotes C.C.N.O.

Subject

P - contd.

	C.N.O. or C.C.N.O. No.
Percussion Detonators - Watertight, Mark VII Lot 141, B.R.8/41 - Withdrawal from service	41/44
Personnel at sea - Emergency ration for - supply of water bottles	136/44
- Awards and Honours to Naval	200,288/44
- Deceased - Cremation of	323/44
- Letters found amongst effects of	36/44
- Storage of effects of	640/44
- Despatch of. to Ships and Establishments in the New Guinea Area	450/44
Sydney for Medical Observation	258/44
- Discharged - Rehabilitation Procedure for	14/44
- Distribution of - Maintenance Bases on Shore and Repair Ships	542/44
- Drafting - Malaria control	118/44
- Employment of, other than officers - rendering mines safe	251/44
for Discharge - Application from	205/44
in Forward Island Areas - special clothing issue for	224,282/44;89/45
- Movements - Reporting of	236/45
- Naval - Food Coupons	266/44
- Liability for further active service	206/44
- Release of	608/44
on leave at Sydney Hospitality Command Amenities Liaison Officer	177/45
- R.A.N. - Remittances	122/45
- Record of - Half-yearly reports on A/S equipment	†148/44
- Release of - for the dairying industry	304/44
- Relief and Leave - Northern Areas	218/45
- R.M.S., for Service Afloat	158/44
Serving at Northern Bases	321/44
- Training of - Asdic installations Type 144/5	†70/44
travelling by troop train - Meals for	368/44;119/45
- Issue of Mess Gear and Blankets to to and from Darwin by the Overland route - Issue of gear	37/44
Petty Officers - R.A.N.R. - Advancement to Chief Petty Officer	290/44
Photographic material for use in H.M.A. Ships and Establishments	8/44
Pillow Slips and Sheets - Conservation of	215/44
Pilotage - Claims for	3/45
Pistols - Depth Charge - Mark VII - Restrictions on issue	415/44
- Issue to D.E.M.S., etc.	†194/44
M.L. 9.5 in. Depth Charge Thrower Mk.II - Use of Correct description	532/44
- Revolver - Losses of	18/44
- Method of Consignment	337/44
- Puff Shots	519/44
Pitting in Engine Room Bilges - A.M.S. Vessels	†69/44
Plague	†207/44
Plugs wood Primer Tube - Depth charges	69/45
P.M.G. Certificates - Eligibility of telegraphist ratings for exemption in certain subjects of the examination for	75/44
Polarized Sun-Glasses - Replacement by Pattern 4074 Anti-Glare Spectacles	125,281/44
Police - Civil - Reports to - Misappropriation of Government Stores	72/44
Force - Engagement of Service Personnel	644/44
Port Adelaide - Refit of A.M.S. vessels at - replenishment of Naval Stores	34/44

† Denotes C.C.N.O.

Subject

C.N.O. or
C.C.N.O. No.

P - contd.

Port Directors	425,514,540,678/44;186/45
- Reduction of Port Moresby to	191/45
Postmen and Orderlies - Correspondence	259/44
Post War Employment - Disclosure of Top Secret etc Information to Civilian Firms	181/45
Practice Expenditure - Depth Charges	†122/44
/Pre-amplifier - Pattern No. (Aust) 420 for Radar Type A 286Q	†17/45
Precautions to be taken when returning C.S.A.M. drums	61/45
when carrying out practices - demonstrations with P.A.C. and Snowflake Rockets	52/44
Precedence, Rank and Command - R.A.N.R. and R.A.N.V.R.	228/45
Preservation of Health - General Hygiene and Sanitation - including the prevention of malaria	269/44
Shells B.L. or Q.F.	68/45
Press - Communications with	133/44
Prices of Clothing, etc., maintained for issue on repayment to Ships' Companies - Amendments of Official Memorandum	51/44
Primers Depth Charge, Mks.VII and VIII and Type "M"	654/44
No.9 Mk.I A.N. - Required for test by I. N.O. Melbourne	149/45
Printed Forms	313/44
Prisoners of War and Personnel interned in Neutral Countries - Pay and Allowances	469/44
Officers - Promotion	426/44
Professional Examination(s) - Advancement to Petty Officer and Leading Seaman	241/45
- Warrant Electrician, R.A.N.	500/44
Engineers and Warrant Mechanics	354/44
Writer and Warrant Supply Officer	353/44
Promotion and Confirmation of Naval Reserve Officers	301/44
of Naval Reserve Ratings to Warrant Rank	499/44
to Temporary Warrant Rank	119/44
Warrant Writer and Warrant Supply Officer - Conditions	289/44
Propellant - Flashless	†144/44
Propeller Shafts - A.M.S. Vessels	†62/44
Propellers and Tailshafts - Base Spares	371/44
Prophylactic Centres - control of venereal disease	†152/44
Prophylaxis - Tetanus	87/44
Protective Clothing	251/44;156/45
Provisions - Accounts for - Necessity for prompt payment	217/44
- Canned - Warranty period of	68,233/44
- Fresh - Contract rates at Melbourne	101/44
or other Victualling Stores - Report or Survey - Form A.S.330 - Rendition of	36/45
Supplied to tenders when absent from parent ship - Accounts for	385/44
- Supply to H.M.A. Ships from U.S. Navy Supply Ships and Depots	153/45
Publicity - Assistance for War Correspondents	184/45
Pumps - Reciprocating - Shuttle Valves - Heat Treatment	107/44
Punishment, Summary - Stoppage of Leave whilst undergoing	251/45
Purchase of Naval Stores - Introduction of Form A.S.133Z in R.A.N. Shore Establishments and Base Depots	419/44
Pusher Hoists 8 in. - Axis Pin of Tumbler Lever Operating Pawl Housing Gear	94/45
Pyrotechnics and Rockets, Signal - Ammunition, Star Shell - All Calibres - Minimum range at which satisfactory functioning can be expended	193/44

† Denotes C.C.N.O.

Subject

C.N.O. or
C.C.N.O. No.

Q

Qualification(s) - Advancement to Chief Shipwright	322/44
Qualified Officer "Status" - Full and Modified grant of	74,132/44
Quarter Bills - Amendments	189/44
Quarterly return of temperatures of storage of Cordite - Forms S.1147a - non-rendering	†100/44
Q.F.40 m.m. Bofors - Liquid in Recoil Buffers	375/44
2 pdr. Mk. XIV Guns and 40 m.m. Rolls Royce Mountings - Disposal	20/45

R

Radar Admiralty Type - Components of	†282/44
Warning and gunnery control sets - Maintenance	†294/44
Aerial Type B.AP/H/M - Maintenance	†206,†211/44
YFP - Modifications	†168/44
Australian Type - Authorized allowances of accessories (Test Equipment)	140/44
Beacons	†240/44
Control and Radar Plot Ratings Detailed arrangements - Reports - Scheme - Policy	543/44
- Scheme - Policy	155,197/45
Courses for Executive Officers	†115,†296/44
Equipment - Allocation of	†142/44
- Spares for U.S.N. Type	†33/44
Escort Vessels fitted with - Modification to Bridge Chart Table	†134/44;†51/45
in A.M.S. Vessels	†9/44
Gyro Compass Repeats	†41/45
Maintenance vessels and A/S - Naming of	†198/44
Observation of fall of shot - communications - Anti-Ship Fire Control	†239/44
Offices - Nomenclature	†225/44
Outfits J.E. - P.P.I. Ventilation	170/45
Reflector - Euston Reef Beacon	†119/44
Security	†46/45
Set A.272 Mark I Local Oscillator Unit	†79/44
Stores for H.M.A. Ships	151/45
Supply, Custody and Accounting	143/45
Test equipment of Australian manufacture	†241/44
Training Establishment	38/45
Transponder, instructions for fitting at R.A.N. Bases - Type 253	†107,†245/44
Type A.79 - Withdrawal	†24/45
Type(s) 253	†96/44
(I.F.F.) Detonators - Fitting and Maintenance - Responsibility	†20,†89,45
253/P,ABK - Suppression when fitted with A.286Q	†52/45
253/P - Fitting and conversion of Type 253 to 253P	†55/45
271/5, A.272, Plywood Lanterns - Maintenance	†58/44
A.272 Mark I, Improved Valve Type NTA 98	†34/44
Obsolescence of Aerial, transmitter - modulator, and aerial control units	†87/44

† Denotes C.C.N.O.

Subject	C.N.O. or C.C.N.O. No.
R - oontd.	
Radar - Type(s) A.272 contd.	
Modification to Overtravel Switch of Aerial System CPT/M ..	†210/44
Transmitter fitting of new matching transformer Type V.50744 ..	†193/44
A286 P/Q - Modification to Aerial Training System A/S 1 and A/S 3 ..	†81/44
A.276 - Fitting ..	†82/43
282M(3)/M(4)/P(1)/P(2), 283, 284M(3)/M(4)/P(3)/- P(4), 285M(3)/M(4)/P(3)/P(4) - Switch Rotary Capacity, Design "E", Pattern - W.3896A Improved Geneva Cross Mechanism ..	†292/44
- W.3896B - Maintenance..	†293/44
285P(5)/P(4)/Q - Provision of spotting tube ..	†90/45
A.286 P/Q - Interference with W/T and R/T Reception - Modification for Listening Watch ..	†48/44 †113/44
A.286 Q ..	†88/44
- Fitting of magnetic screens to 1802 Cathode Ray Tubes ..	†37/45
- Pre-amplifier - Pattern No.(Aust) 420 941/243Q - Introduction ..	†17/45 †100/45
Modification to Oil Seal of BAP/H/M Aerial ..	†219/44
W/T, A/S etc. Equipment Establishment List ..	311/44
Radio Mechanic Branch - Advancement to Chief Petty Officer ..	†25/45
Petty Officer ..	360/44
Radio Mechanic(s)	156/45
Messing in small ships ..	501/44
(R)(W) and (s) - Tool Kits ..	25/45
Rafts - Lifesaving - Release of ..	468/44
Rail Accommodation - Adelaide to Melbourne ..	97/44
Railway Fares - Concession - Service personnel travelling in Uniform and paying their own fares ..	548/44
R.A.N. Armament Depot Darwin - Explosive and Gunwharf Stores for Beach Unit - Mail Address ..	†212/44 †7/45
Destroyers - Accounts ..	237/44
Education Service - Reconstruction Training Scheme ..	524/44
Establishments of Naval Stores ..	135/44
Higher Educational Test - Results - October 1943 ..	156,248/44
- April 1944 ..	439/44
Nursing Service - Administration ..	47/45
- Supply of Nurses Indoor Dresses ..	255/45
Pattern Haze Screens - Modification ..	134/44
Range and Deflection Calculators - "Home Made" ..	472/44
Transmitter from Radar to Transmitting Station ..	546/44
R.A.N.R. and R.A.N.V.R. - Precedence Rank and Command ..	226/45
- Officers - Watchkeeping Certificate ..	256,319/44
Officers - Confidential Reports upon ..	257/44
- Navigational course to qualify for command of an A.M.S. ..	228/44
- Watchkeeping Certificate ..	256,319/44
Petty Officers - Advancement to Chief Petty Officer ..	290/44
Rates of treatment in approved private hospitals ..	203/45
Ratings - Accountant Branch - Temporary commissions ..	366/44
- Advancement of - Training in combined operations ..	221,292/44

† Denotes C.C.N.O.

Subject	C.N.O. or C.C.N.O. No.
R - oontd.	
Ratings - contd.	
- Claim forms for compensation for total loss of uniform - Forms A.S.103y and A.S.103z ..	242/44
- Coder - Temporary Commissions ..	414/44
- Controlled and Observation Mining - Badges ..	7/44
- Convoy Signal ..	104/45
- D.E.M.S. Gunnery - Badges ..	93/44
- Engine Room - Examination of - Results - September 1943 - March 1944 ..	15,191/44 344/44
in Military Detention Barracks - Uniform and Clothing Kits, drafted to Darwin, Thursday Island and New Guinea Areas ..	263/44
- Free - Issue on Entry ..	154/44
- Offences committed by - on passage to and before joining H.M.A.S. "Melville" ..	83/44
- R.N., on loan to the R.A.N. - Disposal of Service Certificates on reversion ..	190/44
- Selection of, for Divers ..	149/44
Serving in Services Reconnaissance Department, Far Eastern Liaison Office and Allied Intelligence Bureau - Advancement of ..	607/44
Stores - (A.S.) ..	167/45
- Submarine Detector - Selection and Aural Care of ..	391/44
- Supply ..	17,172/44
- Telegraphist ..	75/44
Trained in combined operations - Advancement of ..	649/44
Rationing - Clothes ..	630/44
- Bed linen ..	183/44
- Food and food economy ..	265/44
Rations - Action ..	645/44
- Emergency - for aircraft operating from H.M.A. Ships ..	67,445/44
Razor Blades - Safety - Gratuitous issues of ..	496/44
Re-arming with 4" XIX Guns on H.M.L.A. XXIII* Mounting - H.M.A. Ships ..	260/44
Rear Vision Mirrors - Motor Vehicles ..	165/45
Reciprocating Main Engines - Frigates ..	†53/44
Recoil Buffers - Liquid in - Q.F. 40 m.m. Bofors Cylinder Liquid - Gun Mountings - Test of ..	375/44 192/44
Pumps - Shuttle Valves - Heat Treatment ..	107/44
Recommendations for non-substantive rates ..	367/44
Reconditioned Q.P. 2-pdr. H.E. H.V. ammunition ..	†143/44
Record of Naval Store Ledger-Keepers - Introduction of Form A.S.155x ..	298/44
Records - Cordite - Maintenance on board H.M.A. Ships ..	89/44
Red Cross Society - Australian ..	544/44
Reduction of kits in H.M.A. Ships and Shore Establishments ..	241/44
Re-entry of W.R.A.N.S. ratings ..	125/45
Reeving of Becketts - Clips Cartridge No.25 ..	164/44
Refresher escort training organization ..	†55/44
Refrigerating plant for cold room - A.M.S. vessels ..	210/44
Refrigerators - Domestic automatic - Test lamp for ..	488/44;72/45
- Maintenance in H.M.A. Ships and Establishments by the R.A.A.F. ..	128/45
Registration - Confidential correspondence ..	300/44
Regulations - National Security (General) - Navigation and Anchor Lights Order (No.3) ..	343/44
Rehabilitation procedure for discharged personnel ..	14/44
Relatives attending funerals of deceased service personnel - payment of fares ..	274/44

† Denotes C.C.N.O.

Subject

R - contd.

Relatives - contd.	
of Naval personnel - Investigating concerning welfare of	669/44
Release for University study	15/45
of personnel for the dairying industry	504/44
Relics and articles of historical value	†221/44
Remittances by R.A.N. personnel	122/45
Re-naming - H.M.A.S. "Vigilant"	285/44
- H.M.A.S. "Viking"	286/44
Rendering Mines Safe - Employment of personnel other than officers	251/44
of Forms S.1148(h), (i) and (j) - Failures of Armament Material and Ammunition	294/44
Repainting of A.M.S. vessels	110/44
Repatriated Naval Personnel - Liability for further active service	206/44
Repatriation Outpatient Clinic, St.Kilda Road, Melbourne	447/44
Repayment Clothing in Tenders	165/45
Issues of Materials - Uniform and clothing supplies	171/44
Replacements for electrical equipment in M.Ls.	562/44
Replenishment of Naval Stores by A.M.S. vessels refitting at Port Adelaide	54/44
Reports - Ammunition - 20 m.m., 40 m.m., 2-pdr. - 20 m.m.	
Oerlikon H.E. - Withdrawal of certain lots	142/44
- Confidential, on Naval Reserve Officers	257,427/44
- Firefighting Equipment Trials	161/44
School	158/45
- Half-yearly on Asdic Equipment - Record of personnel of Proceedings - Coastal craft	†148/44
H.M.A. Ships	†19/45
Seasickness - Form A.M.1142	†97/45
Stock and Transactions - Guns and Gunmountings	449/44
Stocktaking - Form A.S.148	445/44
Survey on provisions or other Victualling Stores - Form A.S.350	258/45
- Rendering of - Mines washed ashore	56/45
- Stocks of Ammunition	45/44
- Weekly stock - Depth charges and associated stores	166/44
	†47,†64,†72,
	†135/44
Resistances - Charging - D/F and W/T	†51/45
Respirators - Anti-gas - Care of	78/45
- Light Type	596/44
- Painting of Haversacks	582/44
Results - Education Test I - September, 1945	81/44
- December, 1945	203/44
- March, 1944	518/44
- Examination - Engine Room Ratings - September, 1945	15,191/44
- Sick Berth Staff - November, 1945	104/44
- May 1944	458/44
- November 1944	78/45
- Higher Educational Test - October, 1945	156/44
- April, 1944	439/44
Return of empty gas cylinders	48/44
Revocation of certain orders under the Wireless Stations Control Order	80/44
Revolver, Ball Cartridge S.A. .455" - Mark II - Withdrawal	186/45
Pistols - Issues to D.E.M.S., etc.	†194/44
- Losses of	18/44
- Method of consignment	357/44

† Denotes C.C.N.O.

Subject

R - contd.

Revolvers - Accidents	86/44
Ribbons - Medal - Wearing with tropical dress	312/44
Rifles Aiming 1-in. Elswick "A" Supply for use in 4-in. Mark XIX Guns fitted in H.M.A. Ships	614/44;106/45
Breech Covers No.2	208/45
Inspection of	551/44
Slings and universal sling hooks - Use	62/45
R.M.S. personnel for service afloat	158/44
R.N.Forces at Australian Ports - Supplies of Naval Stores	262/45
Ratings on loan to the R.A.N. - Disposal of Service Certificates on reversion	190/44
Rockets - Illuminating - 3½ lb.	40,676/44
- Failure of	570/44
- Prematures	40/44
- P.A.C. - A.M.S. vessels	88/44
and Snowflake - Precautions when carrying out practices or demonstrations	52/44
- Failures	3/44
- Target practice Mark I*, Lots 129 and 144 - Withdrawal - Reports	320/44
2" U.P. Failure	121/44
Roller and ball bearings - Procurement	4/44
Royal Australian Naval Volunteer Reserve - Regs. and Instrns. for Women's Services - Uniform and clothing authorized kit	55,103,128/44
Nursing Service - Wearing of shoulder straps	175/44
Navy Personnel - Australian service hospitals	157/45
- Dental treatment	171/45
Netherlands Navy in Australia - Telegrams for	50/44
R/T Interference - A/S Equipment in M.Ls.	†61/44
W/T Installation Type R.C.8 - Supply of Low Power	†50/45
Rubber sea boots and oilskin clothing - storage of	245/44
Rudders - Fairmile	293/44

S

Saline (Salt) tablets	405/44
Salvage Money - Naval - Distribution	551/44
of condemned unserviceable etc. stores - Army Salvage Service	267/44
Salvers self-contained breathing apparatus, pattern 5485	98/45
Sanitation and general hygiene - Preservation of health, including the prevention of malaria	269/44
Seavalls under motor boat engines	505/44
Scientific section - tropical	271/44
Scuttling charges - Fitting, in Fairmiles, M.Ls. and H.D.M.Ls.	†230/44
Sea Boots and oilskin clothing - Rubber - Storage of	245/44
- Leather - Economy	80/45
Searchers Steel Wire, Pattern 290	450/44
Seasickness - Report of - Form A.M.1142	449/44
Tablets - Issue to Service Afloat	162/45
Seaward Defences - Addresses	63/45
Secret and confidential correspondence - Instructions re acknowledgment, Disposal, etc.	†56/44
- Security of	†99/44

† Denotes C.C.N.O.

Subject	C.N.O. or C.C.N.O. No.
S - contd.	
Security Classifications	†205;411/44
Selection of Ratings for Divers	149/44
Senior Naval Officers Beach Unit	647/44
Combined Operations Section	515/44
Service Afloat - Definition of - 1939-43 Star - Persons eligible Certificates and Pay Accounts of H.M.A. Ships attached to Eastern Fleet	201/44
- On reversion - disposal of - R.N. ratings on loan to the R.A.N.	57,440/44
Chevrons	190/44
Shading Paste - Issue in lieu of paint, dry colour	475/44
Shafting - Misalignment in M.Ls.	44/45
Shell(s) Grabs - 8" Screw Down Type	547/44
- B.L. or Q.F. - Preservation of	591/44
Sheets and Pillow Slips - Conservation of	68/45
Shipment of Mining Stores - Case Markings	215/44
Ships - Landing - Infantry - Administration	59/45
- Ledger and Pay Accounts	†117/44
Shoes - Galley, for Cooks - W.R.A.N.S.	467/44
- Gymnastic for W.R.A.N.S.	77/44
Introduction of Substitute Pattern	19/44
Shore Establishments and H.M.A. Ships - Reduction of kits in H.M.A. - Name Ships	662/44
R.A.N. - Wartime allowances of bedding	241/44
Weekly Report of Stock by - Ammunition - Form A.O.52	270/44
Service at Darwin and Thursday Island - Period of	469/44
New Guinea	326/44
Shoulder straps - Wearing of	680/44
Shuttle valves of Reciprocating pumps - Heat treatment	105/45
Sick Berth Staff - Examination results - November, 1943	175/44
- May, 1944	107/44
- November, 1944	104/44
Sights - Conversion of Mk.IV (100 knots) to Mk.V (100 knots) and fitting of Mk.III Butt Plate - Lewis Machine Guns .303-in.	438/44
Signal(s) and Cypher Logs - Disposal of	78/45
Apparatus - Identification - Indicator Loop	352/44
Indications of their precedence and use	†44/44
Ratings - Convoy	†238/44
Traffic	160,253/45
Sleeves and torches for inflatable lifebelts - Life Saving Equipment	104/45
Small Arms Ammunition - Allowances for shore bases	207/44
- Life throwers, shoulder, coston - Replacement by Rifles M.L.E. line thrower	212/44
- Revolvers - Accidents	†66†101/45
- Rifles and sub-machine guns - Allowances	125/44
- Tools - Plates, Screw and Taps, S.A.	86/44
Ships - Ammunition Outfit of - Arrangements for periodical exchange, examination etc.	†138,†262/44
Soda Ash - Use of, in lieu of soda crystals	435/44
Southern Cross Club, New York	325/44
Spares - Base for propellers and tailshafts	113/44
- Depth charge thrower pistols	460/44
for U.S.N. Type Radar Equipment	371/44
Special clothing for mosquito and sandfly infested areas - Issues for personnel in forward Island Areas	65/44
	†33/44
	224,282.494/44;89/45

† Denotes C.C.N.O.

Subject	C.N.O. or C.C.N.O. No.
S - contd.	
Special - contd.	
Victualling assistance to seagoing ships victualled on the repayment system	444/44
Spectacles - Anti-glare - Pattern 4074 - Supply	30,125,281/44
Supply - General conditions	172/45
- in the New Guinea Area	250/45
Sperry Mark XIV Gyro compass - Condensers - Follow up circuit	579/44
- Repeater Bezel Screws	377/44
- Mod.I Gyro Compass - Incorrect fittings of transmitter connecting cables	514/44
- Mercury Ballistic Caps	378/44
- Oiling of upper vertical guide bearing	376/44
Springs - Barrel Mk.I - Collapse of - Oerlikon guns 29 m.m. Mks. II and IV	350/44
Spur for additional signal Halliards - A.M.S. fitted for mine- sweeping - Alteration and addition	†118/44
Stability - A.M.S. vessels	†177/44
Staff and training requirements division, Navy Office	464/44
Star (1939-43) - Persons eligible, and definition of "Service Afloat"	201/44
Shell allowance	†128/44
Pyrotechnics and rockets, signal - Ammunition - All calibres - Minimum range	195/44
Statements by Service Medical Officers regarding benefits after discharge	482/44
Statutory Rules governing the administration of Women's services - R.A.N.	646/44
Stawell Prize for 1945	251/45
Steam driven boiler room fan engine - Vibration of - A.M.S. vessels	†123/44
Steel chests for A.M.S. vessels	181/44
Furniture - Supply to H.M.A. Ships	356,354/44
Stocktaking - Report - Form A.S.148	258/45
Stocks of Naval Oil Fuel in Australia	†15/44
Storage of Cordite - Quarterly return of temperatures of - Non-rendering - Form S.1147a	†100/44
Explosives in buildings other than Magazines and Explosives Stores	569/44
Oilskin clothing and rubber sea boots	245/44
Storekeeping Ledgers - Naval - Re-arrangement	656/44
Store - Naval - Accounting Procedure - Frigates	244/44
Stores and Supplies - Theft and misappropriation - precautions - Canteen, for H.M.A. Ships	118/45
- Care of - When ships are undergoing repair, etc.	198/45
Condemned, unserviceable, etc. - Salvage of - Army Salvage Service	553/44
- Consumable - Naval Armament Store Accounts - H.M.A. Ships, etc.	267/44
- Damage control - Lockers for	383/44
- Government - Misappropriation of - Reports to Civil Police	506/44
- Medical and Dental - Supply of in the New Guinea Area - Form A.M. 177G Medical Store Accounts for Scale "D" - Scale "E" and Coxswains Set of First Aid In- structions - Booklet - 1944	72/44
- Mining - Shipment of - Case Markings	212/45
- Modification - A/S installations	222/44
- Naval and Defect List Items - Return of	581/44
	59/45
	†99/45
	507/44

† Denotes C.C.N.O.

S - contd.

Stores - Naval - contd.	
Armament Gunmounting and Torpedo - Despatch	
of to Melbourne	43/4
- In D.E.M.S. - Accounting Procedure ..	315/4
- Issued by U.S. authorities	224/4
- Establishment of	625/4
- Incorporated in W/T, A/S, Radar etc. sets -	
Modification of procedure for accounting for	159/4
- Lost by accident, neglect or theft - Procedure	402/4
- On permanent loan - transfer of	491/4
- Procedure for supply etc in Radar and A/S Repair	
and Maintenance vessels	220/4
- Purchases of - Introduction of Form A.S.153Z in	
R.A.N. Shore Establishments and Base Depots	419/4
Returned from H.M.A. Ships and Services - Disposal	186/4
- Replenishment by A.M.S. vessels refitting at Port	
Adelaide	34/4
- Responsibility as to custody in small vessels	687/4
- Supplies to R.N. Forces at Australian Ports ..	262/4
- Permanent Naval - Combustion cones for boilers ..	91/4
- Radar - Supply, custody and accounting	145/4
- Ratings (A.S.)	167/4
Shipped, etc. from H.M.A. Naval Store Depots - Despatch	
of Advance Supply Notes for	642/4
- Discrepancies in	51/4
Transferred from the U.S. Navy to the R.A.N.	456/4
- Victualling - Demands for	663/4
- Non-delivery of, consigned to H.M.A. Ships	
or Establishments	404/4
Stoves - Kerosene, in small craft	173/4
Stowage for firefighting and action repair materials - Minor	
war vessels	†179/4
Stretcher cots - Pattern 474 - Supply	245;535/4
Submarine Detector Ratings - Selection and Aural care of ..	391/4
Sugar - Consumption outside Territorial waters	337;553/4
Suitcases and small blue drill kit bags - Variations in kit ..	234/4
Suits - Brown dungaree combination - Ioan issue to officers ..	112/4
Summary punishment - stoppage of leave whilst undergoing ..	251/4
Sun Glasses - Polarized - Replacement by Pattern 4074 anti-glare	
spectacles	125;281/4
Reflecting device for H.M.A. Ships	35/4
Supply Branch	587/4
of Anti-Glare Spectacles Pattern 4074	30/4
Canteen Stores	283/4
Cigarettes and Tobacco - Personnel on Leave or Discharge	82/4
Civilian clothing to members of the Naval Forces on	
Discharge	214/4
Coal for H.M.A. Ships - Procedure	32/4
Low Power W/T - R/T Transceiver Installation - Type R.C.8	†12;†37/4
Officer, 7th Destroyer Flotilla	180/4
Spectacles - Delegation of authority	297/4
- General conditions	172/4
Stores for Anti-Malarial Measures	15/4
Rating (A.S.) - New Rating	17/4
Ratings and Junior Writers - Typewriting Experience ..	172/4
Suppressive Treatment (Prophylaxis) for Malaria, with Atebrin ..	240/4
Survey on provisions and other Victualling Stores - Reports of	
Form A.S. 330	127;223/4

† Denotes C.C.N.O.

T

Tablecloths and Mats	5,457/44
Tablets - Saline (Salt)	403/44
Tails Propelling Rocket U.2" Mark II - Not to be used	42/44
Tailshafts and Propellers - Base Spares	371/44
Target Practice Mark I*, Rockets, Lot S.129 and 144 - Withdrawal	
Reports	324/44
Targets - Anti-Craft - Kites and Drogues for - Discontinuance of	
Supply	146/44
Telegraphist Ratings - Eligibility for exemption subjects of	
the examinations for P.M.G. and Certificates	75/44
Telephones on Bridge - M.Ls.	417/44
Teleprinter Operators	60,272/44
Temporary Commissions - Accountant Branch Ratings	366/44
- Coder Ratings	414/44
- Selection of Ratings from the Lower Deck	
- Engineering Branch	219/45
- Special Branch R.A.N.V.R.	200/45
Warrant Rank - Promotion to	119/44
Tenders - When absent from Parent Ship - Accounts for provi-	
sions supplied to	385/44
Test Lamp for Domestic Automatic Refrigerators	488/44
of Recoil Cylinder Liquid - Gun Mountings	192/44
Testimonials and Memorial Prizes	25/44
Testing Equipment - W/T - R/T Set - Modification	†80/44
Tetanus - Prophylaxis	87/44
Text Books - Vocational Training	287/44
Theft and Misappropriation of Stores - Precautions	118/45
Thrower Pistols - Depth Charge - Spares	65/44
Throwers - Depth Charge Mark II - Replacement of	†25/44
Time Fuzes No.401 Marks I and IA	153/44
on Board H.M.A. Ships - Annual percentage landing	
in War Time	253/44
Tins, Baking Bread	174/45
Tool Kits for Radio Mechanics (R) (W) and (S)	23/45
Torpedo Ratings and Wiremen	582/44
Tools - Compensation for loss of	184/44
- Machine - Co-ordinated use in Australia between the	
services	611/44
Torches and Sleeves for Inflatable Lifebelts - Life Saving	
Equipment	212/44
Torpedo - Acoustic Homing - Counter Measures to - F.I.R. Gear ..	†120/44
Depot, Darwin	†56/45
Fremantle	65/44
Igniters, Mark XI - Lot 144, Filled SWYN 9/41 -	
Withdrawal	64/44
- Lot No.217, Filled B.R.12/41 -	
Withdrawal	155/44
Total loss of Uniform and Clothing - Compensation for - Ratings	
Training Classes at Balmoral Naval Depot	147/44
Films and Film Strips held on board - Return	246/45
of Personnel - Acting Installations Type 144/5	74/45
Transceiver Installation Type RC.8 - Provision of - Additional	
Crystal	70/44
Transfer of Naval Stores on Permanent Loan	281/44
Officers having charge of stores on Permanent Loan	
.. .. .	491/44
.. .. .	54/45
Transmission of Confidential Messages in plain language over	
Teleprinter Channels	†133/44;†71/45

† Denotes C.C.N.O.

Subject

T - contd.

Transmitter-Receiver - Emergency Frigates	†58/45
Transponder - Radar - Type 253 - Instructions for Fitting at R.A.N. Bases	†107/44
Transport of Coding Machines and Spare Parts	†24/44
Mails in H.M.A. Ships	525/44
Transportation - Service personnel travelling in Uniform ..	57/44
Travel concessions in New South Wales for members of the Forces	355/44
Travelling and Freight Warrant Books - Disposal of	659/44
by Troop Train - Meals for R.A.N. personnel	568/44
- Concession Railway Fares of Service personnel in Uniform and paying their own Fares	548/44
Warrants - Signatures of Issuing Officers on - H.M.A. Ships	674/44
Treatment in approved Private Hospitals - Rates of	305/44
of ex-members of the Forces suffering from malaria which did not manifest itself during the member's service	175/44
Serving Members of the Forces at Repatriation Out-patient Clinic, St. Kilda Road, Melbourne	447/44
Trials - Gun - Procedure	38/44
Tropical Dress - Medal Ribbons	312/44
Outfit Wearing Ashore on the Mainland	564/44
Scientific Section	271/44
Tubes Friction - Machine Rocket Signal Mk.IV - Withdrawal ..	636/44
M.R. Signal - Failures	634/44
- Withdrawal of certain lots	117/45
Vent, Electric 1-in. I.C.I. manufacture	†153/44
Tunios, Drill, with Blue Fascings - Shedding of Dye	71/44
Type AT5/AT8 W/T - R/T Set - Modification	†80/44
A272 Mk.I Radar - Obsolescence of Aerial, Transmitter - Modulator and Aerial Control Units	†87/44
253 - Radar Transponder, Instructions for fitting at R.A.N. Bases	†107/44
Tyres and tubes - conservation of	232/45

U

Unfitness, Physical, for Service - Discharge from R.A.N. on account of	116/45
Uniform(s) and clothing and anti-gas respirators - Return of loan items on Final Discharge	144/45
- Authorized Kits - R.A.N. Women's Services	55/44
- W.R.A.N.S.	20,128/44;137/45
for Ratings in Military Detention Barracks	356/44
- Gratuitous Issues to British and Allied Services	661/44
- Supplies - Repayment Issues of materials	495/44
Officers' - Agreement for the supply of - Inclusion of Uniforms for Nurses and W.R.A.N.S. Officers	213/45
Outfit Gratuities on change of class of	150/44

† Denotes C.C.N.O.

Subject

U - contd.

Uniform(s) - contd.	
- Ratings - Deviation from Standard Patterns	461/44
- Made-to-Measure - Contracts for supply of	405,508/44;121/45
United Kingdom - India, Air Mail	365/44
United States Naval Personnel in Civil Goals - Maintenance ..	113/45
University Study - Release	15/45
Unserviceable American Ammunition - Disposal of	78/44
Condemned etc. Stores - Salvage of - Army Salvage Service	267/44
Flags and Inglefield Clips - Return to Store	69/44
Upper Deck Fittings - H.M.A. Ships - Maintenance of	178/44
Use of Army Medical Facilities in Transfer of Invalids	641/44

V

Vaccination and Re-vaccination	†248/44;88/45
Valedictory - Vice Admiral A.S.Carpender, U.S.N.	24/44
Valve(s) or W/T, Radar etc. services - Accounting	223/45
- Improved Type N.T.A.98 for Radar Type A272 Mark I ..	†54/44
- Shuttle - Reciprocating Pumps - Heat Treatment	107/44
Vanadium Bearing Petroleum Ashes - Collection from oil burning Ships	521/44
Variations in Kit - Small Blue Kit Bags and Suit Cases	234/44
V.C. Recognition Challenge Procedure	†52/45
Vehicles - Naval Motor - Accidents	56/44
Veneral Disease - Control of - Prophylactic Centres	†132,†222/44
- Melbourne Area	40/44
Ventilating Fan - Loss of	66/44
Ventilation - 72 ft. N.D.M.Ls. ex U.S.A.	†79/45
of H.M.A. Vessels	454/44
Wardroom Pantries - A.M.S. Vessels	†89/44
Vessels - A.M.S. - see A.M.S. Vessels	
V.H/F Transceiver Type DR 106 - Installation in H.M.A. Ships ..	†45/45
Vibration of steam-driven boiler room fan engine - A.M.S. vessels	†125/44
Vickers Machine Guns .303" - On Single A.A.Mountings - Butts for Victory Loan	39/44
- Issuing Ship "Merker"	45/45
Victualling Arrangements - Christmas Day 1944	617/44
Assistance - Special - to Seagoing Ships victualled on the Repayment System	444/44
Store(s) - Consignments of to H.M.A. Ships and Establishments - Non delivery of	404/44
- Demands for	665/44;107/45
- Issuing Ship "Merker"	185/45
Vision - Night - Classification by A.R.L. Adaptometer (Mk.III)	345/44
Visual Signallers, Coders, T/P and Automatic Morse Operators - W.R.A.N.S. - Advancement	204,635/44
Training Instructors	55/45
Voice Pipe Communication - A.M.S. Vessels - Alteration and Additions	†105/44
W/S 1 and W/T 1 - Granting of Non-Substantive Rates	420/44

† Denotes C.C.N.O.

Subject

C.N.O. or
C.C.N.O. No.

War Correspondents - Publicity	184/45
Loans - Service Allotments for Continuous Subscriptions to Service - Apprentices	471/44
- Chevrans for	291/44
Wardroom Skylight - Fitting - "B" Type M.Ls.	219/44
- 72 ft. H.D.M.Ls. ex U.S.A.	†98/45
Warrant Engineer and Warrant Mechanician - Professional Examination for	†98/45
Officers - Special Rate of Pay for	554/44;245/45
Rank - Temporary - Promotion to	561/44
Writers and Warrant Supply Officers - Professional Examination	119/44
- Promotion to - Conditions	335/44;244/45
Warrants - Leave Travelling Concession - Issue of	289/44
Warranty period for Provisions	448/44
Wartime allowances of Bedding - R.A.N. Shore Establishments	68,255/44
Washers - Compressed Asbestos Fibre	469/44
- India Rubber, for Hose Couplings - Use of correct patterns	43/45
Watchkeeping Certificate - R.A.N.R. officers	534/44
Water Bottles - Emergency water ration for personnel at Sea - Supply of	256,519/44;2/45
Fresh - Supply to H.M.A. Ships	136/44;6/45
Pressure Test - Gas Cylinders	658/44
Shore - Use of, for Water Tube Boilers	295/44;60/45
Watertight Percussion Detonators - Mark VII Lot 141 B.R.8/41 - Withdrawal from service	†161/44
Wattle Rod Fenders	41/44
Wearing of Shoulder Straps - Royal Australian Naval Nursing Service	280/44
Web Equipment - Pattern 1937	175/44
Weekly report of stock by Shore Establishments	137/44
Stock Reports - Depth Charges and Associated Stores	526/44
Weir Type Feed Pumps	†72,†155/44
Welding and Cutting Equipment - Oxy - Acetylene	504/44
Safe Operating Procedures	436/44
Wills - Compulsory making off	596/44
Wireless Stations Control Order - Revocation of direction under Wiremen - Ratings - Advancement	220/44
Wives and Fiancées - Passports for - Service personnel overseas	80/44
Women's Royal Australian Naval Services - Calculation of Time	556/44
- Convalescent Home for	157/44
- Statutory Rules	597/44
- Uniform and Clothing - Authorised Kit	284/44
Services - Extra Duty Allowance not Payable	646/44
- Procedure when presented to their Royal Highnesses	20,55,105,128/44
Wooden Furniture - Replacement by Steel, in Cruisers, Destroyers, A.M.S. Vessels, and "Warrego" and "Swan"	253/45
Working Suits - Officers carrying out duties of Gunners	249/45
Wound Stripes -	554/44
- Distinction marks for wounded	474/44
Wounds and Injuries by enemy action	185/45
W.R.A.N.S. - Advancement	48/45
- Bedding for	550/44
- Drafting	259/45
	169,586/44
	159/44

† Denotes C.C.N.O.

Subject

C.N.O. or
C.C.N.O. No.

W - contd.

V.R.A.N.S. - contd.	
- Galley shoes for Cooks	77/44
- Gymnastic shoes for	19/44
- Medical attention	572/44
- Members of - Discharged on account of Pregnancy	†116/44
- Professional examination for higher rating - Date of passing	247/45
- Ratings - Made-to-Measure Jackets and Skirts - Contracts for supply of	406,628/44;120/45
- Re-entry of	125/45
- Sick berth ratings - Examination	250/45
- Uniform and Clothing	20,55,105,128/44;157/45
- Visual signallers, coders, T/P and automatic morse operators - Advancement	204/44
- W/T Ratings - Advancement	273/44
Writer Junior and Supply Ratings - Typewriting experience	172/44
W/T and D/P charging resistances	†31/45
, A/S, Radar etc., Equipment - Establishment List	311,502/44
Ratings W.R.A.N.S. - Advancement	273/44
- R.T. Installation Type R.C.8 - Supply of Low Power Testing Equipment for Frigates	†30/45
1 and V/S 1 - Granting of acting non-substantive rates	194/44
	420/44

X

Ray Examinations - Microphotographic	329/44
Films - Shortage	152/45

Z

Zinc sheets and underwater protection of ships and fittings - H.M.A. Ships	517/44
--	--------

† Denotes C.C.N.O.

LIST OF NAVY ORDERS ISSUED BETWEEN 1st JANUARY, 1939, AND
26th JUNE, 1945, WHICH HAVE BEEN CANCELLED.

Cancelled Order	Superseded by	Cancelled Order	Superseded by
<u>1939</u>		<u>1941 - contd.</u>	
39	50/40	113	601/45
50	420/43	127	551/41
85	107/39	129	355/41
96	420/43	133	156/43
158	37/40	134	23/44
159	91/40	135	393/42
		148	103/43
		154	239/41
<u>1940</u>		155	366/41
2	249/40	157	234/42
34	332/42	164	380/43
37	132/41	183	534/42
41	38/41	206	136/45
43	321/44	216	351/43
50	305/44	222	580/44
89	342/42	228	103/43
90	155/40	255	612/44
91	23/41	261	334/42
104	282/42	263	212/42
116	612/44	319	342/42
120	39/41	326	429/43
146	283/40	340	410/42
150	593/42	368	410/42
167	61/44		
178	145/45	<u>1942</u>	
188	250/40	2	105/43
215	578/43	18	256/44
216	304/42	28	429/43
228	489/43	58	448/42
232	528/43	47	561/44
240	504/42	60	250/42
243	580/44	69	104/45
250	73/42	73	446/43
257	498/43	82	230/42
275	359/43	86	230/42
280	237/45	89	446/43
301	515/41	104	359/43
		105	609/44
<u>1941</u>		107	230/42
4	64/41	119	265/44
9	362/43	133	542/42
10	513/43	140	612/44
22	601/43	147	518/45
25	232/43	158	446/43
42	355/41	160	532/42
54	232/41	170	352/43
74	305/44	177	448/42
85	345/44		
103	412/42		

Cancelled Order	Superseded by	Cancelled Order	Superseded by
<u>1942 - contd.</u>		<u>1943 - contd.</u>	
185	519/43	46	127/44
184	414/43	49	104/45
205	505/44	†50	†164/44
219	134/43	56	580/44
230 - Part 2(b)		†60	†63/45
(iii)	375/42	†61	†117/44
- Part 2(q)	210/43	†64	†138/43
239	339/43	†69	†177/44
248	263/43	†83	†131/43
250	480/43	†86	†118/43
281	33/45	93	116/45
282	149/43	†94	†123/43
283	146/44	†98	†71/45
288	339/43	102	53/45
292	263/43	†106	†164/44
293	448/42	†110	†63/45
299	471/43	†112	†255/45
303	149/43	†117	†180/44
304	601/43	118	480/43
313	237/45	†128	†80/44
316	51/45	†130	†83/44
321	525/43	†131	†36/44
331	246/45	†142	†45/44
352	480/43	145	359/43
357	345/44	†150	†63/45
358	446/43	†160	†141/44
360	256/44	†174	†141/44
361	525/43	†175	†36/44
375(b)	210/43	†176	†80/44
385	612/44	†179	†71/44
389	263/43	†180	†164/44
394	197/43	181	188/45
398	519/43	185	49/45
410	218/45	197	235/45
435	390/43	215	241/45
440	351/43	217	305/44
446	263/43	223	145/45
449	102/43	226	158/44
451	587/44	244	257/45
453	525/43	245	265/44
461	480/43	246	446/43
		263	266/44
		284	127/44
<u>1943</u>		311	256/45
2	346/44	313	90/45
†9	†188/44	315	469/44
†20	†63/45	327	190/45
23	436/43	331	241/44
†25	†20/44	355	612/44
†29	†57/43	359	39/45
†34	†36/44	360	257/44
†36	†83/44	392	266/44
40	519/43	412	414/44
41	229/44	440	116/45
45	257/45	446	23/44
†46	†72/44	449	649/44

Cancelled Order	Superseded by	Cancelled Order	Superseded by
1943 - contd.		1944 - contd.	
471	205/45	147	561/44
480	650/44	150	521/44
485	116/45	170	254/45
497	366/44	†175	†280/44
503	354/44	199	425/44
519	543/44	216	59/45
521	265/44	221	649/44
526	425/44	225	36/45
559	375/44	†224	†271/44
576	263/44	249	543/44
578	178/45	257	40/45
582	414/44	259	641/44
584	205/45	264	254/45
594	265/44	270	590/44
664	165/45	†280	†44/45
672	199/45	292	649/44
674	495/44	297	35/45
684	560/44	305	203/45
		317	425/44
		348	643/44
1944		352	211/45
†2	†117/44	393	517/44
10	646/44	407	213/45
†10	†159/44	413	512/44
†13	†36/44	441	38/45
†14	†71/44	458	213/45
17	167/45	489	212/45
†20	†66/45	492	163/45
†35	†80/44	512	180/45
†36	†141/44	526	651/44
39	477/44	552	254/45
†47	†72/44	567	222/45
54	51/45	627	254/45
†64	†72/44	660	213/45
†71	†140/44	680	218/45
76	278/44		
†82	†45/45	1945	
84	543/44	9	200/45
†117	†208/44	†13	†82/45
127	36/45	33	172/45
131	51/45	†44	†94/45
135	625/44	91	140/45
†136	†63/45	102	182/45
†141	†240/44	105	218/45
144	294/44		

RESTRICTED.(FOR OFFICIAL USE ONLY.)

Commonwealth Navy Orders.

Navy Office, Melbourne,
2nd January, 1945.

The following Orders, having been approved, are hereby promulgated for information and guidance, and necessary action.

By direction of the Naval Board,

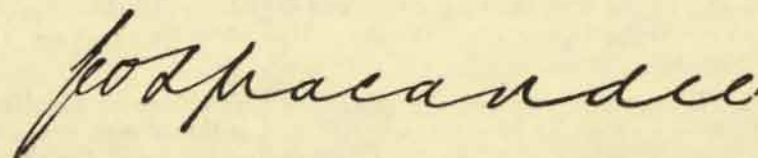

Secretary.

*The Commodore Commanding H.M.A. Squadron,
and Commanding Officers of H.M.A. Ships,
Officers in Charge of H.M.A. Naval
Establishments, and others concerned.*

TABLE OF CONTENTS.

No.	Subject.
1.	Issue of Navy Orders.
2.	Naval Watchkeeping Certificates—Naval Reserve Officers.
3.	Claims for Pilotage.
4.	Precautions against Cholera.
5.	Mileage Allowance—Private Medical Practitioners Attending Members of the Forces.
6.	Emergency Water Containers.
7.	Books and Forms.
	C.13622/44.

1.

ISSUE OF NAVY ORDERS.

The last issue of Navy Orders for 1944 was No. 692.

2.

NAVAL WATCHKEEPING CERTIFICATES—NAVAL RESERVE OFFICERS.

Some doubt appears to exist regarding the award of Watchkeeping Certificates to Naval Reserve Officers.

2. The *Restricted* Watchkeeping Certificate referred to in A.F.O's 3237/41, 4995/44 and Navy Order 256 of 1944 is required only as a qualification for promotion to the rank of Lieutenant during war and does not replace the *Full* Naval Watchkeeping Certificate referred to in King's Regulations and Admiralty Instructions—Article 261. The *Full* Naval Watchkeeping Certificate may be granted after three months' service at sea on Watchkeeping duties and is to be to the effect that the officer concerned is competent to take charge of a Watch at sea as a Lieutenant.

3. The standard required for this Naval Watchkeeping Certificate is the same as that for Lieutenant R.A.N. and is thus a high one. The Certificate is to be granted by the Commanding Officer of the ship in which the officer is serving, or by the Senior Officer on the recommendation of the Commanding Officer of the ship. *It is not to be granted by an officer of lower rank than that of Lieutenant-Commander in Command.*

4. Officers who have been granted this certificate are entitled to the Symbol (W.K.) against their name in the Navy List.

5. These instructions are contained in A.F.O. 3288/40, but, as *Full* Watchkeeping Certificates are being issued by Officers junior to Lieutenant-Commander in Command, they are repeated in this Navy Order for the information and guidance of all concerned.

(453/202/962.)

3.

CLAIMS FOR PILOTAGE.

The attention of officers is drawn to the following matters which should be kept in mind when forwarding claims for pilotage.

2. Claims, which should be forwarded quarterly, are to be rendered on Form AS. 454 to the Naval Officer-in-Charge, Sydney.

3. Navigating Officers' claims require the certificate of their Commanding Officers. Where Officers in Command are claimants, the

certificate of the Senior Naval Officer under whose orders the services were performed is required. In the case of a Flotilla the certificate of the Administrative Authority is required.

4. Pilotage is limited to six times in and six times out of any one port unless in a ship of a larger class.

5. Pilotage is payable only in respect of those ports mentioned in O.U. 5254/38 and Confidential Commonwealth Navy Order 151 of 1944.

6. Where it is considered that exceptional circumstances warrant the payment of pilotage in cases other than those mentioned in paragraph 5 hereof, pilotage claims should be forwarded to the Administrative Authority for his recommendation, and not to the Naval Officer-in-Charge, Sydney, unless this latter is the Administrative Authority.

7. The following are applicable to claims for pilotage:—

O.U. 5254/38. Information as to the payment of pilotage, etc. Confidential Commonwealth Navy Order 151 of 1943—Payment of pilotage, etc.

Consolidated Orders and Regulations, Article 342.

Naval Financial Regulations and Instructions, Article 76.

Naval Account Regulations and Instructions, Article 76.

(407/218/418.)

4.

PRECAUTIONS AGAINST CHOLERA.

There is evidence that Cholera has been spreading south and east from epidemic centres. Spread to the New Guinea area is a possibility. The following procedures are therefore to be observed:—

A talk or lecture on the nature of Cholera and the methods of preventing its spread is to be given by all medical officers of ships and shore establishments north of Brisbane. A similar lecture is to be given to all drafts proceeding to tropical areas.

2. This disease is characterized by the sudden onset of vomiting and diarrhoea, accompanied by violent pains and cramps in the muscles. The stools are at first coloured, but, in the later stages, colourless fluid is passed resembling water with particles of rice in it. Fluid is rapidly drained from all the tissues and the patient shrinks visibly. The disease is commonly conveyed by water.

All excreta from the patient are dangerous and should be disposed of, preferably by burning. Failing this, they should be disinfected by adding equal quantities of strong disinfectant such as carbolic acid or lysol, and thrown overboard or buried as far as possible from human habitation and from the sources of water supply.

3. Medical officers of ships and establishments, or where no medical officer is borne, Commanding Officers are to ensure that all personnel

4. serving in or proceeding to tropical areas have been inoculated against Cholera including stimulating doses.

5. The attention of all concerned is drawn to the necessity of ensuring that all water used for drinking and domestic purposes on shore in New Guinea and in ships where water is drawn from the shore is adequately chlorinated.

6. Any case suggestive of Cholera is to be immediately isolated and arrangements made for bacteriological investigation by the nearest competent authority. The Naval Board is to be informed without delay.

7. A supply of certain drugs, utensils, etc., will be assembled at Milne Bay, or the next advanced R.A.N. Medical Store Depot, to be available for issue only if required.

8. Attention is drawn to Confidential Commonwealth Navy Order 149 of 1944.

(527/211/2080.)

5.

MILEAGE ALLOWANCE—PRIVATE MEDICAL PRACTITIONERS ATTENDING MEMBERS OF THE FORCES.

With reference to paragraph 3(i)(c) of Navy Order 218 of 1943, the following mileage rates are approved in the case of Civilian Medical practitioners attending members of the Forces:—

MILEAGE.

Country.—Two miles free. Beyond two miles (one way only)—
8 a.m. to 8 p.m.—5s. per mile;
8 p.m. to 8 a.m.—7s. 6d. per mile.

Metropolitan.—Two miles free. Beyond two miles (one way only)—
8 a.m. to 8 p.m.—3s. 6d. per mile;
8 p.m. to 8 a.m.—5s. per mile.

Mileage charges shall be calculated from the Doctor's surgery.

2. Navy Order 218 of 1943 is amended accordingly.

(1919/2/56.)

6.

EMERGENCY WATER CONTAINERS.

Emergency water containers for use in life floats will shortly be available, on demand, from Royal Edward Victualling Yard, Sydney, and from all H.M.A. Victualling Depots.

2. Four 29-oz. cans of sterilized water, and four plastic drinking cups with embossed ring on the inside to indicate a measure of $1\frac{3}{4}$ fluid ounces, are enclosed in each container which is sealed and readily floats in salt water as long as it is watertight. To retain such buoyancy special care is to be taken, when opening cases or handling the containers, to guard against their becoming punctured or otherwise damaged. In this connexion it is important that the hand grip of the tear-off tops should not be used for lifting or other handling of the containers.

3. As the cans contain sterile water and are hermetically sealed, containers are on no account to be opened, except for the separate stowage of individual cans in life floats, if desired, until an emergency necessitating the consumption of the contents arises.

4. The containers (dimensions $9\frac{3}{8}$ -in. square by $5\frac{9}{16}$ in. high) about to be issued are too high to fit into the compartments of life floats provided with double gratings, and ships should make the best use of those containers, or the individual cans therein, for such life floats until special containers of reduced height become available at a later date when a further Navy Order in the matter will be issued.

5. Initial supplies of containers are to be demanded by H.M.A. Ships at the first opportunity up to the full requirements of life floats on board. In this connexion special attention is drawn to the provisions of paragraphs 9 and 10 of Section IV of A.F.O. 3111/1944. All supplies should be taken on charge in the Provision Account.

6. With reference to Navy Order 67 of 1944, the 29-oz. cans (and outer container) will also be supplied for use by aircraft operating from H.M.A. Ships in substitution for 35-oz. cans, the manufacture of which has been discontinued.

(668/201/2926.)

7.

BOOKS AND FORMS.

First supplies of the under-mentioned publications have been distributed. Further supplies of B.R.'s 274, 454, 644F, 854, 1065, 812/44 are being obtained to complete distribution:—

B.R.70/1944.—Signal Letters of British Ships and March Supplement.

(A.F.O. 3891/44.)

(571/202/2042.)

B.R.274/1943.—Handbook and Drill for 20 m.m. Oerlikon Machine Gun, Marks II, II U.S.N. and IV U.S.N. on Marks I, II_A, III_A, IV U.S., V U.S., VII_A and VIII_A Mountings.

(A.F.O. 5915/43.)

(571/202/2003.)

Addendum No. 1 to B.R.292.—Instructions for the Maintenance of Naval Ordnance and Gun Mountings, 1942.

(A.F.O. 3891/44.)
(571/202/1929.)

B.R.299/1943.—Handbook of Signalling Equipment (other than V/S) Fitted in H.M. Ships.

(A.F.O. 2686/44.)
(571/202/2066.)

Errata No. 8 to B.R.358 and Form D.254_n.—Establishment of Naval Stores for Executive Purposes and List of Particulars.

(A.F.O. 1735/44.)
(571/202/1503.)

Errata No. 6 to B.R.372/1939.—Establishment of Naval Stores for Minelaying Lighters.

(A.F.O. 3891/44.)
(571/202/1944.)

Errata No. 3.—Establishment of Naval Stores for "Fairmile" Craft.

(571/202/1488.)

B.R.454.—Notes on Navigation (For Higher Educational Tests—Navigation 1) Revised 1942.

(571/202/2004.)

B.R.644_F.—Q.F. 4-in. Mark V Gun, Fuze 206 Based on Range Table No. 358A.

(C.A.F.O. 2124/42.)
(571/202/1672.)

Amendment No. 38 to B.R.664.—King's Regulations and Orders for the Army.

(A.F.O. 2686/44.)
(571/203/126.)

Annexe Nos. 44-46 to B.R.695.—List of International Telegraph Offices.

(571/202/1814.)

B.R.764.—All the World's Aircraft, 1942.

(A.F.O. 4507/43.)
(571/202/1846.)

B.R.792.—Visual Signalling Instructions.

(A.F.O. 2016/44.)
(571/202/2001.)

B.R.812/44 (late B.R.812/1943).—Drill for 40 m.m. Mark IV Guns on Twin Marks IV and IV* Mountings.

(A.F.O. 3642/44.)
(571/202/2048.)

B.R.819(3).—Regulations for Naval Armament Services, Part III, Vols. A, B and C.

(A.F.O. 1428/44.)
(571/203/2498.)

B.R.854.—Torpedo Control Pocket Book (Destroyers).

(A.F.O. 3891/44.)
(571/202/2037.)

B.R.919(6).—Handbook on the H.A.C.S. Scooter Control Unit, Aided Training Box and Sector Alignment Gear as fitted to the H.A./L.A. Directors, Marks V, V* and IV G.B.

(A.F.O. 1886/44.)
(571/202/1910.)

B.R.1034(2).—Handbook of Components, Firing Systems and Testing Apparatus for Independent Non Contact Mines: Pamphlet No. 2—Testing Apparatus.

(A.F.O. 4427/44.)
(571/202/1949.)

B.R.1044.—Drill for the 5-in. U.S. 38-Calibre Mark 12 Mod. 1 Gun on the 5-in. U.S. Mark 30 Mod. 50 Mounting.

(A.F.O. 3084/44.)
(571/202/2025.)

B.R.1061/44.—Drill for the 4.7-in. Q.F. Mark IX** Gun on C.P. Mark XXII Mounting and 4.5-in. Q.F. Mark IV. Gun on C.P. Mark V Mounting, 1944.

(A.F.O. 3220/44.)
(571/202/2024.)

B.R.1065/44.—First Fitting and Maintenance of Escort Oilers' Equipment.

(A.F.O. 2535/44.)
(571/202/2007.)

O.U.6353.—British Merchant Vessels Lost from Outbreak of War—May Supplements and Amendments.

O.U.6353A.—Foreign Merchant Vessels Sunk and Damaged by the Enemy from Outbreak of War—May Supplements and Amendments.

(A.F.O. 4427/44.)
(571/203/2460.)

A.P.1480A.—Amendment List No. 109—Silhouettes of British Aircraft.

A.P.1480B.—Amendment List Nos. 39 and 40—Silhouettes of German Aircraft.

A.P.1480c.—Amendment List No. 25—Silhouettes of Italian Aircraft.

A.P.1480e.—Amendment List No. 8—Silhouettes of Russian Aircraft.

A.P.1480f.—Amendment List No. 18—Silhouettes of Japanese Aircraft.

(A.F.O. 2016/44.)

A.P.1480/1.—Amendment List Nos. 22 and 23.—Silhouettes of American Aircraft.

(A.F.O. 2686/44.)

A.P.1480z/2.—Amendment List No. 3—D.E.M.S. Aircraft Recognition Handbook.

(A.F.O. 4427/44.)

(571/201/4155.)

A.T.I.U. No. 31.—Aircraft Recognition Sheets.

(480/201/2379.)

Army Training Memorandum (War) (Australia) No. 36.

(546/201/443.)

Aircraft Recognition Journal Volume II, Nos. 9 and 10.

(415/201/1879.)

By Authority: H. E. DAW, Government Printer, Melbourne.

Library
8—16/45.

RESTRICTED.

(FOR OFFICIAL USE ONLY.)

Commonwealth Navy Orders.

Navy Office, Melbourne,
9th January, 1945.

The following Orders, having been approved, are hereby promulgated for information and guidance and necessary action.

By direction of the Naval Board,

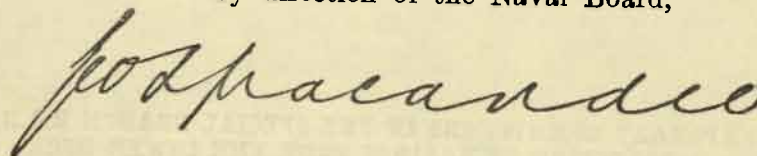

Secretary.

*The Commodore Commanding H.M.A. Squadron,
and Commanding Officers of H.M.A. Ships,
Officers in Charge of H.M.A. Naval
Establishments, and others concerned.*

TABLE OF CONTENTS.

No.	Subject.
8.	British Naval Office, San Francisco.
9.	Temporary Commissions in the Special Branch R.A.N.V.R.—Selection of Ratings from the Lower Deck.
10.	Grant of Acting Lieutenant Commander's Rank to Permanent Lieutenants R.A.N.R. (S), R.A.N.R. and R.A.N.V.R.
11.	Officers Promoted Direct from Warrant Rank to Lieutenant—Qualification for Promotion to Commander.
12.	A.M.S. Vessels—Axial Flow Fans.
13.	Depth Charges Dropped for Practice.
14.	Store Allowance—"Bathurst" Class Australian Minesweepers.
15.	Release for University Study.
16.	Corrigendum.

C.183/45.

8.

BRITISH NAVAL OFFICE, SAN FRANCISCO.

The British Naval Office, Western Sea Frontier, San Francisco, covers the activities of the British Naval Liaison Office and the British Routeing Liaison Office, and handles the distribution of British naval signals to all British activities in San Francisco.

2. It is located in Room 423, Federal Building—Telephone Market 3828, local 502 or 696, and is manned between 0900 and 1700 on week days.

3. Arrangements have been made whereby the British Naval Liaison Officer will act as the representative of the Naval Board on the West Coast of U.S.A.

4. In this capacity he will arrange transportation of R.A.N. personnel across the Pacific, and generally look after the interests of the R.A.N.

5. Signals may be sent direct to the British Naval Liaison Officer.

(549/201/157.)

9.

**TEMPORARY COMMISSIONS IN THE SPECIAL BRANCH R.A.N.V.R.
—SELECTION OF RATINGS FROM THE LOWER DECK.**

The Naval Board have decided that Reserve and Hostilities Only ratings, of all branches, may be considered for promotion to commissioned rank in the Special Branch, R.A.N.V.R.

2. Officers of the Special Branch are employed on the following duties:—

Executive—Special.
Operations—Special.
Intelligence.
Armament Store Accounting.
Sea Transport.
Naval Control Service.
Rail Transport.
Mercantile Movements.
A/S Fixed Defences.
Controlled Mining.
R.M.S. & B.S.
C.B.'s.
D.E.M.S. (Gunnery duties).
Boom Defence Service.
Radar.
Meteorological.

Other categories may be added as the necessity arises. Cypher officers are excluded from the above, promotion for this purpose being open to coders only, *vide* Navy Order 582 of 1943.

3. Forms C.W.1 should be commenced for ratings considered suitable for promotion to commissioned rank for any of the foregoing duties.

4. (a) *Medical Standard*.—Candidates must be free from any gross physical defect and must not suffer from any condition that is likely to become aggravated by duty, or render them incapable of carrying out their duty efficiently. Varicocele or varicose veins are not a cause of rejection unless very marked.

(b) *Visual Standard*.—The visual standard is as laid down in A.F.O. 2474/43, with the following modification.

Colour vision below Grade III can be accepted in respect of candidates recommended for employment on the following duties:—

Executive duties on shore.
Photographic duties.
A/S Fixed Defences.
Controlled Mining.
Interpreter.

Special Branch Officers for employment on the following duties must have colour vision of at least Grade III:—

Radar.
H.F./D.F.
Meteorological.

6. *Executive—Special (Ex. S.)*.—Ratings who cannot be recommended for executive commissions on account of being below the medical standard required for the Executive Branch may be recommended for temporary commissions in the Special Branch of the R.A.N.V.R. to undertake general duties of an executive nature on shore. In addition, ratings who are 35 years of age or over may be recommended for temporary commissions in the Special Branch, irrespective of their medical category, if they are considered to be more suitable for employment in that branch than in the Executive Branch.

7. Ratings recommended for promotion in terms of this Order will be drafted to Flinders Naval Depot for a disciplinary course, together with any other course considered necessary, before final selection and promotion.

(436/201/116.)

10.

**GRANT OF ACTING LIEUTENANT COMMANDER'S RANK TO
PERMANENT LIEUTENANTS R.A.N.R. (S), R.A.N.R. AND
R.A.N.V.R.**

Attention is directed to A.F.O. 5140/44 which has been adopted in the R.A.N.

2. Naval Reserve Officers of the Permanent Lists, R.A.N.R. (S), R.A.N.R. and R.A.N.V.R. appointed prior to 3rd September, 1939, will be eligible for consideration for promotion under the provisions of A.F.O. 5140/44. Naval Reserve Officers of the Temporary List, R.A.N.R. (S), and those R.A.N.R. and R.A.N.V.R. Officers appointed on or subsequent to 3rd September, 1939, will be eligible for promotion under the provisions of A.F.O. 3927/44, *vide* Navy Order 607 of 1944.

3. All officers who are in the zone for promotion under the provisions of A.F.O. 5140/44 are to be reported upon half-yearly whether they are recommended for promotion or not, including those who have been granted the rank or relative rank of Acting Lieutenant-Commander "whilst holding their present appointment".

4. Promotions under the provisions of A.F.O. 5140/44 will be made at half-yearly intervals to date 1st November and 1st May respectively. Reports on Forms S.206 are required to reach the Secretary, Naval Board, not later than 15th March and 15th September, respectively.

5. Separate covering Forms S.596 are to be used for R.A.N.R. (S), R.A.N.R. and R.A.N.V.R. respectively.

6. The first selection of permanent Reserve Officers who are in the zone will be made for the promotions to be effected on 1st May, 1945.

7. Particular attention is drawn to the two categories of officers referred to in paragraph 2 of this Order.

8. So far as Officers of the R.A.N.R. (S) are concerned, the differentiation between "Permanent" and "Temporary" Appointees is apparent in the Commonwealth of Australia Navy List—namely, R.A.N.R. (S) Officers are shown on the Temporary List of that Force. No such distinction is, however, apparent between "Permanent" and "Temporary" appointees of the R.A.N.R., R.A.N.V.R. and R.A.N.V.R. (Sp. Br.) Lists.

9. Should there be any doubt as to the date of appointment to the Naval Reserves of Officers concerned, Commanding Officers or Administrative Authorities should call for the "Notification of Appointment to the Naval Reserves" from the Officer, or, failing this, the necessary information should be obtained from the Secretary, Naval Board, by signal, if necessary.

(432/205/5567.)

11.

OFFICERS PROMOTED DIRECT FROM WARRANT RANK TO LIEUTENANT — QUALIFICATION FOR PROMOTION TO COMMANDER.

The provisions of A.F.O. 4993/44 have been adopted in the Royal Australian Navy.

(568/201/954.)

12

A.M.S. VESSELS—AXIAL FLOW FANS.

All A.M.S. Vessels fitted with 18-in. axial flow fans manufactured by A.C.I. Ltd., Sydney, are to report to the Naval Officer-in-Charge, Sydney, whether spare armature and switchgear spares for this type of fan have been supplied and are on board.

(524/216/291.)

13.

DEPTH CHARGES DROPPED FOR PRACTICE.

Depth charges dropped with a depth setting greater than the depth of water, although in more than the minimum depth required to fire, may still fail to fire due to mud and sand from the sea bottom blocking the orifice of the depth adjuster.

2. Under action conditions, this possibility of failure to fire can be accepted.

3. Unless the circumstances are exceptional, depth charges are not to be dropped for practice unless the depth of water is greater than the desired depths to be set on the pistols, and in order to avoid unnecessary restrictions on shipping movements, due to failure to fire, depth charges are not to be dropped for practice in frequented harbours or on traffic routes.

(471/205/2368.)

14.

STORE ALLOWANCE—"BATHURST" CLASS AUSTRALIAN MINESWEEPERS.

It is notified that in *Bathurst* Class A.M.S. in which the full naval stores accounting is followed in accordance with B.R.4 involving the use of ledgers, rates of store allowance payable are as laid down in K.R. & A.I., Appendix VIII, clause 16 (c).

2. Subject to the provisions of K.R. & A.I., Appendix VIII, the Executive Armament Officer appointed in lieu of a Commissioned Gunner, or Commissioned Gunner (T) or Gunner or Gunner (T) may be credited with the authorized allowance of 6d. a day whilst carrying out the appropriate duties and rendering accounts provided that in no case shall such payment be made prior to 7th November, 1944.

(407/220/129.)

15.

RELEASE FOR UNIVERSITY STUDY.

Arrangements have been approved for the consideration of applications from serving personnel for release for University study. Only a very limited number of vacancies are available for all three Services.

2. Applications to resume or commence courses will be considered. The conditions of eligibility for consideration and the procedure of application in each case are:—

A. Applications for Release to Resume Courses.

(a) *Reserved Faculties.* Students, with over one year's service and whose pre-enlistment records were reasonable, may apply for release to resume interrupted courses in medicine, dentistry, engineering, science, veterinary science, agriculture and architecture.

(b) *Unreserved Faculties.* Students whose pre-enlistment records were better than average may apply for release to resume interrupted courses in arts, law, economics or commerce, music or education, if—

- (i) the course they desire to resume can be completed in not more than two years and they have had at least two years' service; or
- (ii) the course they desire to resume can be completed in not more than three years and they have had at least three years' service.

Application Procedure.

Applicants should make application to the Commanding Officer and to the Registrar of the University. Each application should show—

- (i) The University at which enrolment is sought.
- (ii) The University attended before enlistment.
- (iii) The course followed and the standard reached before enlistment.
- (iv) The last year of University attendance before enlistment.
- (v) The date of enlistment for full-time service.

The letter to the University should mention that application for release has been made to the Commanding Officer.

Applications should be made without delay. No application received after 31st January can be considered.

B. Applications for Release to Commence Courses.

(a) Personnel who enlisted before reaching the age of 21, who have had three years' service, and who are qualified to commence University courses, may be considered for release.

Application Procedure.

Applicants should make application to the Commanding Officer and to the Registrar of the University. Each application should show—

- (i) The University at which he desires to commence a course;
- (ii) the course in which enrolment is sought;
- (iii) all particulars of his qualification to commence that course including the name of the examination, the State in which that examination was taken, the year of the examination and the school from which the applicant was a candidate. In addition, any details of the pass which the applicant can furnish should be shown;
- (iv) the applicant's age on enlistment; and
- (v) the date of enlistment for full-time war service.

The application to the University should show that the applicant has applied to his Commanding Officer.

Applications should be made without delay. No application received after 31st January can be considered.

(b) Other personnel who have had more than two years' service and who are qualified to commence University courses may apply to Universities for selection within the civilian quota.

Application Procedure.

A form of application for enrolment should be obtained from the Registrar of the University at which enrolment is sought. This completed application should reach the University not later than 31st January (excepting Western Australia, where the closing date is 19th January).

Application should also be made to the Commanding Officer for release.

(840/201/10.)

CORRIGENDUM.

With reference to paragraph 14 of Navy Order 666 of 1944—
“Machinery Spares—Organization, etc.”—for “Fig. 3” read “Fig. 2”.

RESTRICTED.(FOR OFFICIAL USE ONLY.)

Commonwealth Navy Order.

Navy Office, Melbourne,

16th January, 1945

The following Orders, having been approved, are hereby promulgated for information and guidance, and necessary action.

By direction of the Naval Board,

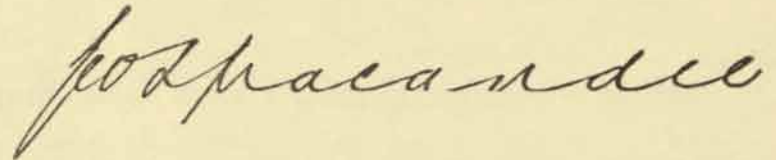

Secretary.

*The Commodore Commanding H.M.A. Squadron,
and Commanding Officers of H.M.A. Ships,
Officers in Charge of H.M.A. Naval
Establishments, and others concerned.*

TABLE OF CONTENTS.

No.	Subject.
17.	Director of Women's Royal Australian Naval Service.
18.	Duties of Principal Medical Officer—New Guinea.
19.	Medical Officers—Requests for Demobilization.
20.	Q.F. 2 pdr. Mk XIV Guns and 40 m.m. Rolls Royce Mountings—Disposal of.
21.	Pattern 10—Boiler Water Gauge Glass Packing Rings.
22.	Apparatus A.D. Type L.
23.	Tool Kits for Radio Mechanics (R), (W) and (S).
24.	B.R. 826/43 and B.R. 861/43—Drill for the Fuzekeeping clock.

C.437/45.

17.

DIRECTOR OF WOMEN'S ROYAL AUSTRALIAN NAVAL SERVICE.

First Officer S. McClemons has been appointed as Director of the Women's Royal Australian Naval Service. She will be responsible to the Naval Board for the general organization of the Women's Royal Australian Naval Service, for the morale and well being of its personnel, and for advising the Board on all matters affecting this responsibility.

2. She will be consulted by the Departments concerned on all matters likely to affect the morale and well being of W.R.A.N.S. personnel, e.g., pay, conditions of service, accommodation and the general aspects of victualling, messing and clothing.

3. She is responsible for the recruiting of W.R.A.N.S. ratings. Drafting and advancement of W.R.A.N.S. ratings will be the responsibility of the Naval Officer-in-Charge, Flinders Naval Depot.

4. She will be responsible for all recommendations to the Naval Board regarding appointments and promotion of W.R.A.N.S. Officers.

5. She, or her representative, is authorized to visit any naval establishment in which W.R.A.N.S. personnel are employed, giving prior notification to the Naval Officer-in-Charge of the establishment.

(432/224/2752.)

18.

DUTIES OF PRINCIPAL MEDICAL OFFICER—NEW GUINEA.

The Medical Officer attached to the staff of the Naval Officer-in-Charge, New Guinea, has been given the title of Principal Medical Officer, New Guinea, and his duties are:—

- (a) to exercise general supervision over the hygiene and health of the personnel under the command of Naval Officer-in-Charge, New Guinea, and to advise the latter on any matters of medical importance;
- (b) to pay frequent visits to all depots, port directorates, &c., for the purpose of the above supervision;
- (c) to supervise and direct the work of naval medical officers in New Guinea—*Ladava*, *Basilisk* and *Madang*—including the medical officer attached to the staff of Commander (D) and the medical officers of depot ships, e.g., *Whang Pu*, whilst in New Guinea;
- (d) to advise and direct the hygiene officer in regard to his duties;
- (e) to furnish a monthly report of his activities, together with a summary of the health of personnel in New Guinea, to the Naval Officer-in-Charge, New Guinea, and forward a copy to Director of Naval Medical Services;
- (f) to furnish the Combined Advisory Committee on Tropical Medicine, Hygiene and Sanitation, with monthly statistics of tropical diseases in the R.A.N. in New Guinea, a copy being forwarded to the Director of Naval Medical Services.

(559/214/2485.)

19.

MEDICAL OFFICERS—REQUESTS FOR DEMOBILIZATION.

The attention of all medical officers who desire to apply for demobilization is drawn to the necessity for carrying out the correct Service procedure when forwarding applications.

2. All such applications are to be forwarded to the Secretary, Naval Board, through the Commanding Officer of the ship or establishment in which the officer is serving. Applications should not be forwarded to Man Power Department or to the various State Medical Co-Ordination Committees.

3. Except under exceptional circumstances, consideration will not be given to applications for demobilization unless the applicant has served for three years as a fully mobilized medical officer in the Naval Forces.

(825/201/9.)

20.

Q.F. 2 PDR. MK. XIV GUNS AND 40 M.M. ROLLS ROYCE MOUNTINGS—DISPOSAL OF.

Q.F. 2 pdr. Mk. XIV guns and 40 m.m. Rolls Royce mountings together with spare parts, &c., special to these equipments are to be brought to produce.

2. Depots and bases are however to retain temporarily sufficient spare parts, &c., to service guns still mounted until the latter are replaced by other weapons.

(490/208/678.)

21.

PATTERN 40—BOILER WATER GAUGE GLASS PACKING RINGS.

It has been discovered that a number of pattern 40 packing rings in stock and on issue, are 1/64-in. to 1/32-in. oversize across the flats and 1/8-in. to 3/16-in. too deep.

2. Stocks of pattern 40 gauge glass packings are to be examined and any rings which do not conform to specification are to be returned to the nearest naval store depot for disposal.

(524/203/1526.)

22.

APPARATUS A.D. TYPE L.

Navy Office message 171049.Z. July, 1943, relating to the withdrawal of apparatus A.D. type L, Mark I.A., lot 92, is hereby cancelled.

2. The lot number as quoted refers to the bomb portion only and Admiralty Fleet Order 705/44 now covers this restriction.

(471/208/1161.)

23.

TOOL KITS FOR RADIO MECHANICS (R), (W) AND (S).

With reference to A.F.O.'s 5080/41, 2793/42 and 4355/44, approval has been given to the provision of modified sets of tool kits for use of Radio Mechanics (R), (W) and (S). A list of the items comprising the kit is contained in paragraph 5 below.

2. The tool kits are to be issued to Radio Mechanics (R), (W) and (S) on completion of their qualifying course and such issues noted on their Service certificates. Ratings who have already qualified and have not been issued with their tool kits are to apply for them through their Commanding Officer.

3. The kits will be issued outright to Permanent Naval Force ratings and become the personal property of the individuals, who will be responsible for maintaining them up to full scale. Replacements of tools lost, broken or worn out may be made from Service sources, on repayment, providing the Commanding Officer is satisfied that the circumstances are such that replacements cannot be obtained from commercial sources.

4. Issues to "Hostilities only" ratings will be a personal issue, but will remain the property of the Crown. Articles lost, broken or worn out will be replaced from the naval store, subject to the value of any tools lost, or damaged by misconduct or neglect being recovered in accordance with K.R. and A.I., Article 1936.

5. The tools of kit referred to are:—

Pattern Number.	Description.	Number.
83	Locks brass pad, 1½"	1
2A	Drills, hand	1
78	Files, round, taper, bas., 8"	1
382	.. hand, bastard, 1 safe edge, 6"	1
400	.. hand, smooth, 1 safe edge, 6"	1
120	File cleaners	1
C.612	Hammer, B.P., 8 oz., w/handle	1
1398	Pliers, insulated	1
or		
467	.. bellhangers	1
987	.. roundnose, 4"	1
480	Punches, nail or pin, 3/16"	1
765	Rules, steel, engineers, 12"	1
665	Screwdriver, cabinet, 8"	1
3604	.. watchmaker, 8"	1
3600	.. watchmaker, 3" x 3/16"	1
3606	Spanners, adj., King Dick	1
C.345	Brushes, flag squirrel,	2
C.279	.. sash tool, No. 6	1
763	Handles for files	2
3717	Boxes, tool	1
	<i>R.A.A.F.</i>	
	<i>Number.</i>	
DIB/25338	Pliers, angle, cutting, 6"	1
DIB/1821	Punches, centre, 4"	1
3190	Screwdrivers, instrument makers, 3/64", 1/16", 5/64", 3/32"	1 set

5.—continued.

Pattern Number.	Description.	Number.
5579	Spanners, box, 0 B.A. x 2 B.A. D.E., 9" long	1
5580 box, 4 B.A. x 6 B.A. D.E., 9" long	1
5054 S.E., 4 B.A.	1 set
5438 folding 2-4 x 6 B.A.	1
3594	Tweezers, watchmakers	2
6	DIA/3545 Cleaners, contact, No. 1	1
7	DIA/3587 Gauges, feeler, No. 1 (2-18 mils)	1
10 Pliers, adj., No. 1, duckbill bent, 5 ₂	1
12	DIC/2176 Screwdrivers, watchmakers, 3 x 3/16"	1
23	DIC/3154 Spanners, flat, No. 3 (9/32" x 5/16"), SAE Herbrand	85

(2037/8/96.)

24.

B.R. 826/43 AND B.R. 861/43—DRILL FOR THE FUZEKEEPING CLOCK.

The following local amendment is to be made to all copies of B.R. 826/43 (page 27, after line 15) and B.R. 861/43 (page 25, after line 36):—

If the Radar Rate Cut Lamp goes out.

- Matches the black inclination pointer to the red.
- Applies rate spotting (if necessary) to make the black range pointers move at the same speed as the blue pointers (or the red pointers if the Radar Range Cut Lamp has also gone out).

(571/202/1790.)

DEPARTMENT OF DEFENSE
LIBRARY.

RESTRICTED.(FOR OFFICIAL USE ONLY.)

Commonwealth Navy Orders.

Navy Office, Melbourne,
23rd January, 1945.

The following Orders, having been approved, are hereby promulgated for information and guidance and necessary action.

By direction of the Naval Board,

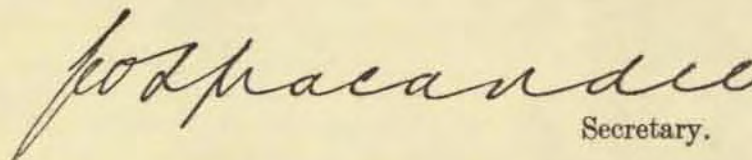
Secretary.

*The Commodore Commanding H.M.A. Squadron,
and Commanding Officers of H.M.A. Ships,
Officers in Charge of H.M.A. Naval
Establishments, and others concerned.*

TABLE OF CONTENTS.

No.	Subject.
25.	Higher Educational Test, October, 1944—Results.
26.	Consultant Ear, Nose and Throat Specialist.
27.	Depth Charge Pistols Mk. VII—Modification to Mk. VII*.
28.	Gassing in Depth Charges.
29.	Guns—Lewis and Savage Lewis 0.303-in.—Magazines 97 Rounds Fitted with Lengthened Catch.
30.	Bofors 40 m.m. Ammunition—Policy in Regard to Issue.
31.	Anti-Flash Gear.
32.	Fuzes, Percussion, D.A., No. 230.
33.	Supply of Spectacles—General Conditions.
34.	Australian Army Canteens Service Issuing Points.
35.	Correspondence for Naval Store Depot, Melbourne.
36.	Reports of Survey on Provisions or Other Victualling Stores—Forms A.S. 330.
37.	Books and Forms.

C.708/45.

HIGHER EDUCATIONAL TEST, OCTOBER, 1944—RESULTS.

The pass results obtained by candidates in subjects taken by them in the Higher Educational Test held between the 17th and 20th October, 1944, are as given hereunder. Included in these results are the pass marks obtained by each candidate at previous examinations where such marks are higher than those obtained at the October, 1944, examination.

Name.	Rating.	Official No.	Where serving at the time of Examination.	Papers.									Summary.
				I.	II.	III.	IV.	VII.	VIIA.	VIII.	IX.		
				General Knowledge.	English History.	Geography.	Navigation.	Practical Mathematics.	M. th. for A/Py. Sub.-It.	Mechanics.	Magnetism and Electricity.		
Allerton, James W. ..	Able Seaman ..	S/8918	<i>Arunta</i> ..	72		
Briggs, Ronald G. ..	Able Seaman ..	PM/6354	..	63	81	86	..	70	..	H.E. Cert., 2nd Class	
Campbell, William C. ..	Elect. Art., 3rd Class ..	S/5800	..	77	97	..	90	..	H.E. Cert., 1st Class	
Campbell, William D. ..	Able Seaman ..	S/8598	65		
Cathcart, John D. ..	Ord. Seaman ..	PM/7207	..	68	64	..	75	76	H.E. Cert., 2nd Class	
Hansen, John R. ..	Shpt., 3rd Class ..	H/1043	..	63	96		
McCarthy, Bernard D. ..	A/Chief Petty Officer ..	9794	..	75	77(<i>uu</i>)	96(<i>uu</i>)	Q.W.R. ; H.E. Cert., 1st Class	
Rieger, John D. ..	Able Seaman ..	PA/3492	..	69	64		
Symons, William M. ..	Able Seaman ..	PM/5212	..	71	..	61	80	66	H.E. Cert., 2nd Class	
McPherson, Colin E. ..	A/Chief E.R.A. (Ty.) ..	22627	<i>Burdekin</i> ..	57(<i>qq</i>)	..	61(<i>rr</i>)	..	76	Q.W.R.	
Belt, Robert ..	Petty Officer ..	19658	<i>Cerberus</i>		
Cox, Roy A. ..	Act. E.R.A., 4th Class ..	H/2719	71		
Rutherford, Raymond A. ..	Petty Officer ..	21826	..	56(<i>vv</i>)	72	
Savage, Frederick J. ..	Petty Officer ..	20940	70	
Sheldon, John ..	Petty Officer ..	20326	..	61(<i>ii</i>)	..	64(<i>ii</i>)	55	
Smith, Raymond W. ..	Petty Officer ..	20302	..	68	..	58		
Kollosche, Harold ..	Mech., 1st Class ..	18664	<i>Hobart</i> ..	67	82(<i>nn</i>)		
McGregor, George A. ..	E.R.A., 3rd Class ..	22698	..	64		
White, Harry M. ..	Mech., 1st Class ..	20675	..	59	84(<i>tz</i>)	..	78(<i>tz</i>)	..		
Feasey, Edgar J. ..	Petty Officer W.T.R. ..	23322	<i>Kuranda</i> ..	79(<i>qq</i>)	83(<i>qq</i>)	78(<i>rr</i>)	Q.W.R. ; H.E. Cert., 1st Class	
Dicks, Thomas V. ..	Chief E.R.A. ..	20522	<i>Kuttabul</i>	79		
Lea, Thomas ..	Petty Officer Wtr. ..	22237	<i>Maitland</i> ..	86	80	Q.W.R.	
Kemp, John S. ..	Able Seaman ..	PM/6580	<i>Melville</i>	71		
Webster, Alexander F. ..	Able Seaman ..	S/8175	(including Boom Defence)	57		
Hanson, Henry T. ..	Ldg. Tel. ..	24099	<i>Quickmatch</i> ..	58	..	69	..	100(<i>pp</i>)	Q.W.R.	
Fraser, Martin ..	Ldg. Stoker ..	22467	..	57	..	68	Q.W.R.	
Clark, Ivor R. ..	S.B. Petty Officer ..	14470	<i>Rushcutter</i> ..	81	Q.W.R.	
Phillips, Ross H. ..	Ldg. S.B.A. ..	S/2932	..	68	Q.W.R.	
Williams, Patrick Y. ..	Petty Officer ..	21527	..	70	..	75	90	Q.W.R.	
Bartels, Gregory ..	Ord. Seaman ..	S/8954	<i>Shropshire</i> ..	70	61	Q.W.R.	
Harper, John ..	Chief Petty Officer Wtr. ..	20799	..	77	66(<i>gg</i>)	Q.W.R.	
Golding, Edwin J. ..	Petty Officer Wtr. ..	23796	<i>Basilisk</i> ..	82	80	Q.W.R.	
Davidson, Malcolm A. ..	Sy. Petty Officer ..	22231	Supply Officer (D) Colombo	70	..	71	Q.W.R.	
Eccleston, John T. ..	C.P.O. Writer ..	20765	..	68(<i>uu</i>)	..	78(<i>uu</i>)	..	98	Q.W.R.	

(*gg*) Marks obtained at April, 1936, examination.
 (*nn*) Marks obtained at October, 1930, examination.
 (*qq*) Marks obtained at April, 1941, examination.
 (*tz*) Marks obtained at October, 1942, examination.
 (*vv*) Marks obtained at October, 1943, examination.

(*ii*) Marks obtained at April, 1937, examination.
 (*pp*) Marks obtained at October, 1940, examination.
 (*rr*) Marks obtained at October, 1941, examination.
 (*uu*) Marks obtained at April, 1943, examination.
 (*ww*) Marks obtained at April, 1944, examination.

Maximum marks in each subject—100.
 75 per cent. of total marks is considered a first-class pass.
 55 per cent. of total marks is considered a second-class pass.

2. The marks obtained by candidates in subjects in which they did not pass are not shown above. Should any candidate desire to be informed of these marks, he should make application to the Commanding Officer of the ship or establishment in which he is serving, who has been supplied with a statement of the full results obtained at the examination. Notation of the award of Higher Educational Certificates and Qualified for Warrant Rank (Q.W.R.) should be made on the service certificates of the ratings concerned.

(This Order will be reprinted for posting on Notice Boards.)

26.

CONSULTANT EAR, NOSE AND THROAT SPECIALIST.

Dr. E. M. Steel, M.B., Ch.M., 135 Macquarie-street, Sydney, N.S.W., has been appointed Consultant Ear, Nose and Throat Specialist in Sydney, to the Royal Australian Navy in succession to Dr. Richard Francis, M.B., Ch.M., F.R.A.C.S. (Deceased).
(527/201/959.)

27.

DEPTH CHARGE PISTOLS MK. VII—MODIFICATION TO MK. VII*.

It has been decided to convert all Mk. VII depth charge pistols to Mk. VII*.

2. All pistols Mk. VII held on board and by bases are to be returned to the nearest Naval Armament Depot and an equivalent number of pistols Mk. VII* or VII** is to be demanded in lieu.

3. R.A.N. Armament Depots are to report on 28th February, 1945, the quantities of Mk. VII pistols held and whether the work of conversion can be carried out in depot.

(471/205/2164.)

28.

GASSING IN DEPTH CHARGES.

The amount of moisture in the charge contributes largely to the evolution of an inflammable gas from minol and torpex fillings.

2. Pending further instructions, all depth charges filled minol are to be examined, immediately before or during issue, for damaged or loose bungs which might permit ingress of water. Though the work need not be regarded as a laboratory operation, it should be carried out remote from the main stack of depth charges. Examination on a truck or at the quay, segregated from other charges, would be a satisfactory arrangement.

3. Any charges found with loose or damaged bungs are to be examined under laboratory conditions for moisture or gassing of the filling, a non-ferrous tool being used for removal of the bungs. If no gassing is found, and the filling is dry and if the depth charge is otherwise satisfactory, new bungs should be fitted and the depth charges accepted as serviceable. If any gassing is found, the store must be set aside and dealt with under Article 699c of Regulations for Naval Armament Services, Part II. The depth charge should be sentenced "unserviceable—to be dumped", if the filling is found to be wet.

(437/201/825.)

29.

GUNS—LEWIS AND SAVAGE LEWIS 0.303-IN.—MAGAZINES 97 ROUNDS FITTED WITH LENGTHENED CATCH.

Ships to which magazines 97 rounds fitted with long catches are issued should fire them on all guns on which they will be used. Any gun on which failures occur is to be exchanged, if possible, or the long catch magazines returned and short catch magazines drawn instead.

2. As the lengthened catch eliminates the use of a post magazine auxiliary, particular care is to be taken to ensure that a post magazine auxiliary is not fitted to the gun when using long catch magazines.

3. A.F.O's 1383/42, 6028/42 and 3003/44 refer.

(490/212/1198.)

30.

BOFORS 40 MM. AMMUNITION—POLICY IN REGARD TO ISSUE.

With reference to Navy Order 653 of 1944, arrangements should be made to ensure that, if available, Australian made 40 mm. Bofors ammunition is supplied to ships whose stowage is fitted to take Australian ammunition boxes only.

(408/206/1472.)

31.

ANTI-FLASH GEAR.

Anti-flash gear, when issued, is proofed in a solution of borax and boracic acid in water. Washing this gear removes a large proportion of this proofing and thus lowers its efficiency.

2. To retain the efficiency of anti-flash gear it is therefore directed, that, if washing is considered necessary for any reason, this gear is to be immediately reproofed in the solution referred to above. Battle dress shirts and trousers are also to be proofed, and reproofed each time washing is necessary. Ships concerned are to demand the necessary materials. Directions for proofing and reproofing of anti-flash gear are given in the Manual of Victualling, Volume I, Chapter 12, Article 5, paragraphs 5 and 6.

3. Officers and ratings whose duties preclude the wearing of anti-flash gloves as at present issued are to cut away those parts necessary to allow wearing of gloves and still permit efficient performance of duty.

4. In action, battle dress trousers are to be worn tucked into socks.

5. Airtex type shirts should no longer be issued for battle dress.

(434/214/593.)

32.

FUZES, PERCUSSION. D.A., No. 230.

Future supplies of fuzes percussion D.A. No. 230 will be of the Mark V type which differs from Mk. IV only in the striker cover.

2. This is secured in the Mk. V as firmly as in Mk. IV, but has the walls thinned to increase sensitivity against light targets.

3. Fuzes converted to embody this striker cover will become Marks I****, II*** or IV*.

4. When available, initial supplies of modified fuzes, percussion, D.A., No. 230 will be forwarded by the Superintending Armament Supply Officer, Sydney, without demand, to the following, in the order shown:—

Yunnan	3,000
New Guinea Bases	4,500
Townsville	500
Cairns	100
Thursday Island	125
Brisbane	250
Darwin	1,350
Fremantle	1,000
Adelaide	70

5. Ships are to obtain modified fuzes from the nearest of these supply points. Quantities of other marks of fuzes, No. 230 are then to be returned to the R.A.N. Armament Depot, Maribyrnong, at the first opportunity.

(471/209/1398.)

33.

SUPPLY OF SPECTACLES—GENERAL CONDITIONS.

The following conditions relating to the supply of spectacles at Service expense are consolidated from various previous instructions and are to be adhered to in all cases.

2. (a) Reading Spectacles—

Glasses for reading may be supplied at the public expense to ratings of all branches irrespective of the age of the ratings, when recommended by an ophthalmic specialist.

(b) Spectacles for constant wear—

Ratings (including W.R.A.N.S.) with the exception of those shown below (*vide* (b) (i)) are permitted to wear spectacles constantly and may be supplied with them at the public expense, when recommended by an ophthalmic specialist.

(i) The following ratings are not permitted spectacles for constant wear:—

Seaman ratings for general service (*vide* (b) (ii)).

Signal ratings for general service.

Stokers and leading stokers.

W.R.A.N. visual signallers.

(ii) Seaman ratings on shore duties only and in immobile gate vessels (boom defence) may wear glasses constantly and be supplied at the public expense, when recommended by an ophthalmic specialist.

The following seaman ratings:—Q.O. (in Cruisers and above), Radar, S.D., S.T.—may wear glasses at their specialist work, and be supplied at public expense, when recommended by an ophthalmic specialist.

3. Officers of the Naval Forces (including the Women's Services of the R.A.N.), and members of the Auxiliary Services other than the Shore Wireless Service, are *not* entitled to the supply of spectacles at public expense unless spectacles are lost or damaged as a result of a casualty of the Service. The prescription for spectacles may, however, be loaned to these members in order that purchase may be arranged privately.

4. Approval for supply of spectacles is in each case to be obtained on Form A.M. 250z subject to supply being recommended by an ophthalmic specialist who should indicate whether the spectacles are required for near or distant vision. As a wartime measure, authority has been delegated to Naval Officers-in-Charge in each State of the Commonwealth for the grant or refusal of spectacles where the proposed supply is in accordance with the conditions contained hereunder. Form A.M. 250z is to be prepared in each case and submitted to the Naval Officer-in-charge, who, if the supply is in order, will approve and sign the form in lieu of the Director of Naval Medical Services.

At the end of each month, the forms A.M. 250z for those spectacles supplied during the month are to be forwarded to the Director of Naval Medical Services.

5. The supply of spectacles at Service expense is to be arranged through the qualified opticians under contract with the Department, and in accordance with the terms of the contract unless unnecessary delay would occur in adopting this procedure. In such instances, the commanding officer is to make satisfactory local arrangements for supply by a qualified optician and is to satisfy himself that the price is reasonable having due regard to the prices obtaining in the district where the purchase is made.

6. Seaman ratings with sea experience who are found to be below the proper visual standard should not be relegated to shore service if this can be avoided. As an alternative, application should be made for their employment or transfer as follows in the order given:—

- (i) Qualification as an S.D. Operator, S.T., for service in cruisers, and above. Q.O., Radar, or for training as an electrical, engine room, ordnance artificer or motor mechanic. These ratings, with the exception of S.D. Operators, are permitted the constant wearing of spectacles on duty. S.D. ratings may wear spectacles on duty only when in cabinets.
- (ii) Transfer as seaman to boom defence service, i.e., for draft to immobile gate vessels and shore service only.
- (iii) Transfer for further sea service to any other branch in which the constant wearing of spectacles is permitted.

It is the intention that each case should be judged on its merits. Transfer to the Supply Branch should be avoided unless for some reason in a limited number of cases the men concerned are particularly suitable for such a transfer. It should be noted that the spectacles supplied under this clause should correct to at least 6/6. 6/9.

7. In all cases where any doubt exists as to a member's eligibility for spectacles at Service expense, the matter is to be fully reported to the Director of Naval Medical Services and his approval obtained before any action is taken to arrange supply.

8. Navy Orders 281 of 1942 and 297 of 1944 are cancelled.

(527/201/793.)

34.

AUSTRALIAN ARMY CANTEENS SERVICE ISSUING POINTS.

Australian Army Canteens Service Issuing Points at Milne Bay and Dobodura have been closed, and new issuing points have been established at Aitape, Bougainville and Jacquinot Bay.

2. The appendix to Navy Order 484 of 1944 is to be amended accordingly.

3. The R.A.A.F. Canteens Service has established an issuing point at Milne Bay and will make supplies available, if required, for Naval personnel in the area.

(427/201/922.)

35.

CORRESPONDENCE FOR NAVAL STORE DEPOT, MELBOURNE.

All correspondence for the Naval Store Depot, Melbourne, should in future be addressed as follows:—

The Officer-in-Charge,
Naval Store Depot,
Esplanade West,
PORT MELBOURNE.

2. All consignments of goods, packages, &c., should, however, until further notice, continue to be forwarded to the Officer-in-Charge, Naval Store Depot, 344 City-road, South Melbourne, as laid down in Navy Order 547 of 1943.

(443/201/1424.)

36.

REPORTS OF SURVEY ON PROVISIONS OR OTHER VICTUALLING STORES—FORMS A.S. 330.

The attention of accountant officers, also commanding officers of ships where an accountant officer is not borne, is drawn to the procedure in regard to the preparation and rendition of form A.S. 330—“Report of Survey on Provisions or other Victualling Stores Damaged, Defective or Decayed”.

2. Detailed instructions for rendering reports of survey are embodied in the printed form and particular care is to be taken to insert in each column of A.S. 330 the full details required. In this connexion the revised form referred to in paragraph 3 of Navy Order 602 of 1944 is to be brought into use immediately supplies are received.

3. Special attention is drawn to the necessity for the original copy to be despatched direct to the Director of Victualling, except in the case of reports of survey raised in tenders which, after signature of the commanding officer, are invariably to be forwarded immediately to the parent ship for examination and endorsement prior to transmission to Navy Office. As accounting for victualling stores in tenders is the direct responsibility of the commanding officer, the signature of a supply or other rating in certificates, &c., in this form will not be accepted.

4. Where destruction of stores is necessary, a certificate of actual destruction is to be inserted in the body of the form and signed by at least two officers witnessing such destruction.

5. Where condemnations of fresh provisions are due to refrigerator defects, a full explanation of the circumstances is to be stated either in A.S. 330 or in a covering memorandum and advice furnished of the action taken to effect repairs.

6. It has been noted from examinations of reports of survey submitted to Navy Office that considerable losses of emergency provisions stowed in ships' boats have occurred owing to deterioration. It is essential that such provisions be frequently inspected and changed as necessary, not only for the purpose of preventing deterioration but also to ensure that the contents of packages are in a fit state for consumption should the emergency for which they are provided arise.

7. In order to reduce, as far as is practicable, the present excessive condemnations of provisions which frequently arise in tenders owing primarily to A.S. 104, "Numbers and Contents Book", not being maintained, special care is to be taken in those ships to issue provisions strictly in order of their date of receipt on board. In addition, regular inspections of storerooms are to be made with the object of guarding against losses or damage on account of insect life, rust, defective or unsatisfactory stowage, &c.

8. Navy Orders 127 and 223 of 1944 are cancelled.

9. The necessary amendment to C.O.R. 1942, Volume I, Article 439, will be promulgated in due course.

(612/243/975.)

37.

BOOKS AND FORMS.

The under-mentioned forms have been introduced for use in the R.A.N. First supply will be effected, without demand, by the Superintending Naval Store Officer, Sydney:—

S.1515 (revised 1943).—Report of Attack by Enemy Aircraft.

S.1515A.—Air Defence Log.

(480/202/3872.)

T.245.—Sea Transport Stores.

T.246.—Sea Transport Stores.

(480/201/3483.)

DEPARTMENT OF DEFENCE
LIBRARY.

RESTRICTED.

(FOR OFFICIAL USE ONLY.)

Commonwealth Navy Order.

Navy Office, Melbourne,

30th January, 1945.

The following Orders, having been approved, are hereby promulgated for information and guidance, and necessary action.

By direction of the Naval Board,

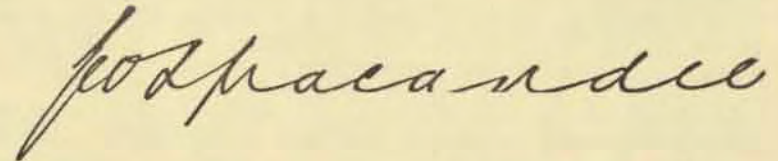

Secretary.

*The Commodore Commanding H.M.A. Squadron,
and Commanding Officers of H.M.A. Ships,
Officers in Charge of H.M.A. Naval
Establishments, and others concerned.*

TABLE OF CONTENTS.

No.	Subject.
38.	H.M.A. Radar Training Establishment.
39.	Promotion of Naval Reserve Officers to Rank or Relative Rank of Lieutenant-Commander or Acting Lieutenant-Commander-Naval Reserves.
40.	Confidential Reports on Naval Reserve Officers.
41.	Grant of Acting Rank or Relative Rank of Lieutenant-Commander-Naval Reserves.
42.	Bofors 40 M.M. Gun—Improved Unloading Mask.
43.	Compressed Asbestos Fibre Washers for Engine Room and Boiler Room Lighting Fittings.
44.	Paint, Dry Colour—Issue of Shading Paste in Lieu of.
45.	Third Victory Loan.
46.	Books and Forms.

38.

H.M.A. RADAR TRAINING ESTABLISHMENT.

The title of "Officer-in-Charge, H.M.A. Radio School" has been changed to "Commanding Officer, H.M.A. Radar Training Establishment."

2. This establishment has been commissioned as H.M.A.S. *Watson* with accounts carried in H.M.A.S. *Rushcutter*.

3. The responsibilities of the Commanding Officer, H.M.A. Radar Training Establishment are:—

- (a) General instruction in radar and associated equipment, of all officers and ratings as required.
- (b) Technical radar training of radar officers, radio mechanics and radar plot and radar control ratings. These latter ratings will be trained in the fire control portion of their course by the Gunnery School, Elinders Naval Depot.
- (c) General instruction of all officers and ratings concerned (including ships' teams) in action information centre, fighter direction and associated R/T procedure.

4. Correspondence previously addressed to H.M.A.S. *Rushcutter*, H.M.A. Radio School or R.A.N. Station 284, on matters relating to radar training and drafting should now be sent to "The Commanding Officer, H.M.A. Radar Training Establishment, Watson's Bay, N.S.W." Signals should be addressed to "H.M.A.S. *Watson*."

5. Correspondence relating to all matters concerning policy, design, production, installation and maintenance should be addressed to the Secretary, Naval Board. Section C of A.C.B. 247 will be amended accordingly.

6. Matters relating to radar training, drafting, advancements, &c., which were previously addressed to the Naval Board and/or the Naval Officer-in-Charge, Flinders Naval Depot, should continue to be so addressed.

7. Navy Order 441 of 1944 is cancelled.

(549/201/137.)

39.

PROMOTION OF NAVAL RESERVE OFFICERS TO RANK OR RELATIVE RANK OF LIEUTENANT-COMMANDER OR ACTING LIEUTENANT-COMMANDER-NAVAL RESERVES.

The following summary of instructions concerning the promotion of Naval Reserve Officers to the ranks of lieutenant-commander and acting lieutenant-commander is promulgated for information and necessary action.

2. Lieutenant-commander (or relative rank) R.A.N.R. (S), R.A.N.R. and R.A.N.V.R.

(i) Attention is drawn to—

(a) B.R.62—Regulations for the R.N.R. (Officers)—Article 51, clause 8; Article 52, clause 4; and Article 53, clause 2. These R.N.R. conditions for promotion govern the promotion of R.A.N.R. (S) officers—*vide* Naval Reserve (Sea-going) Regulations and Instructions, Article 10.

(b) Naval Reserve Regulations and Instructions, Articles 60, 63 and 68 governing the promotion of R.A.N.R. and R.A.N.V.R. Officers.

(ii) Commanding Officers are to forward their recommendations in respect of—

(a) R.A.N.R. (S) officers as they become eligible.

(b) R.A.N.R. and R.A.N.V.R. officers not later than 15th May and 15th November—*vide* Naval Reserve Regulations and Instructions, Article 52.

(iii) Reports on Form AS.206 are to be rendered for all officers who are qualified irrespective of whether they are recommended for promotion or not. These reports are to be rendered through the administrative authority, who will forward them with his recommendations under cover of Form AS.596.

3. Acting lieutenant-commander (or relative rank) R.A.N.R. (S), R.A.N.R. and R.A.N.V.R.

(i) Attention is drawn to A.F.O's 3927/44 and 5140/44 and to Navy Orders 607 of 1944 and 10 of 1945.

(ii) Reports on Form AS.206 (d) are to be rendered half-yearly for all officers who are qualified, irrespective of whether they are recommended for promotion or not. These reports are to be rendered through the administrative authority, who will forward them with his recommendations under cover of Form AS.596 to reach the Secretary, Naval Board, not later than 15th February and 15th August for officers reported upon under A.F.O. 3927/44, and not later than 15th March and 15th September for officers reported upon under A.F.O. 5140/44.

4. Navy Order 359 of 1943 is cancelled.

(428/211/216.)

40.

CONFIDENTIAL REPORTS UPON NAVAL RESERVE OFFICERS.

The following Order consolidates previous instructions upon this subject.

2. Confidential reports are required on Naval Reserve officers as follows:—

(a) *Commanding Officers:*

- (i) When ship or the officer commanding her leaves the Station or squadron.
- (ii) When the senior officer under whose orders the ship has been employed is relieved.

(b) *All Other Officers:*

- (i) When the ship pays off.
- (ii) When the commanding officer is superseded.
- (iii) When an officer's relief is appointed or where an officer is appointed elsewhere without relief.
- (iv) When specially called for by the Naval Board.

(c) *Paymaster Sub-Lieutenants:*

When the accountant officer is superseded.

(d) *Probationary Officers:*

On completion of three months' mobilized service from date of promotion from the lower deck or first appointment from shore. Special reference should be made to the fitness of the officer for confirmation in rank.

(e) *Midshipmen:*

To reach Navy Office immediately prior to attaining the age of 19½ years. Special reference should be made to the officer's fitness for promotion. If this report coincides with that required under sub-paragraph (d) above, confirmation and promotion should be dealt with in the one report.

(f) *Acting Sub-Lieutenants (or Equivalent Rank):*

To reach Navy Office immediately prior to attaining six months' seniority. Special reference should be made to the officer's fitness for promotion.

(g) *Sub-Lieutenants (or Equivalent Rank):*

To reach Navy Office immediately prior to attaining the necessary qualifying service for promotion to the rank of lieutenant or lieutenant (provisional).

(h) *All Officers:*

On recommendations being made under the following provisions:—

A.F.O. 4067/44—Accelerated promotion to lieutenant rank.

A.F.O's 4916/43, 4572/44, 4064/44 —“Qualified Officer” status.

A.F.O's 3927/44, 5140/44, Navy Orders 359/43, 10/45—Acting lieutenant-commander and lieutenant-commander.

A.F.O. 6080/43—Fighter direction officers (after six months' service).

(j) *Warrant Officers and Commissioned Officers from Warrant Rank:*

On recommendation for promotion—to reach Navy Office by 1st June and 1st November each year.

3. Attention is directed to *K.R. & A. I.*, Article 865; *C.O.R.* Article 227 and *Navy Order* 301/1944.

4. It is impressed upon reporting authorities that Forms S.206 should be rendered as early as possible on or after the occasions enumerated above.

5. Navy Order 257 of 1944 is cancelled.

(428/211/215.)

41.

GRANT OF ACTING RANK OR RELATIVE RANK OF LIEUTENANT-COMMANDER-NAVAL RESERVES.

With reference to Navy Order 607 of 1944, paragraph 5 is cancelled.

(432/205/5569.)

42.

BOFORS 40 M.M. GUN—IMPROVED UNLOADING MASK.

An improved type of unloading mask for 40 m.m. Bofors gun has been designed as shown in D.O.T.M. Drawing No. 79993, appended to this Order.

2. The mask may be manufactured by ships' staffs if desired.

(514/201/2760.)

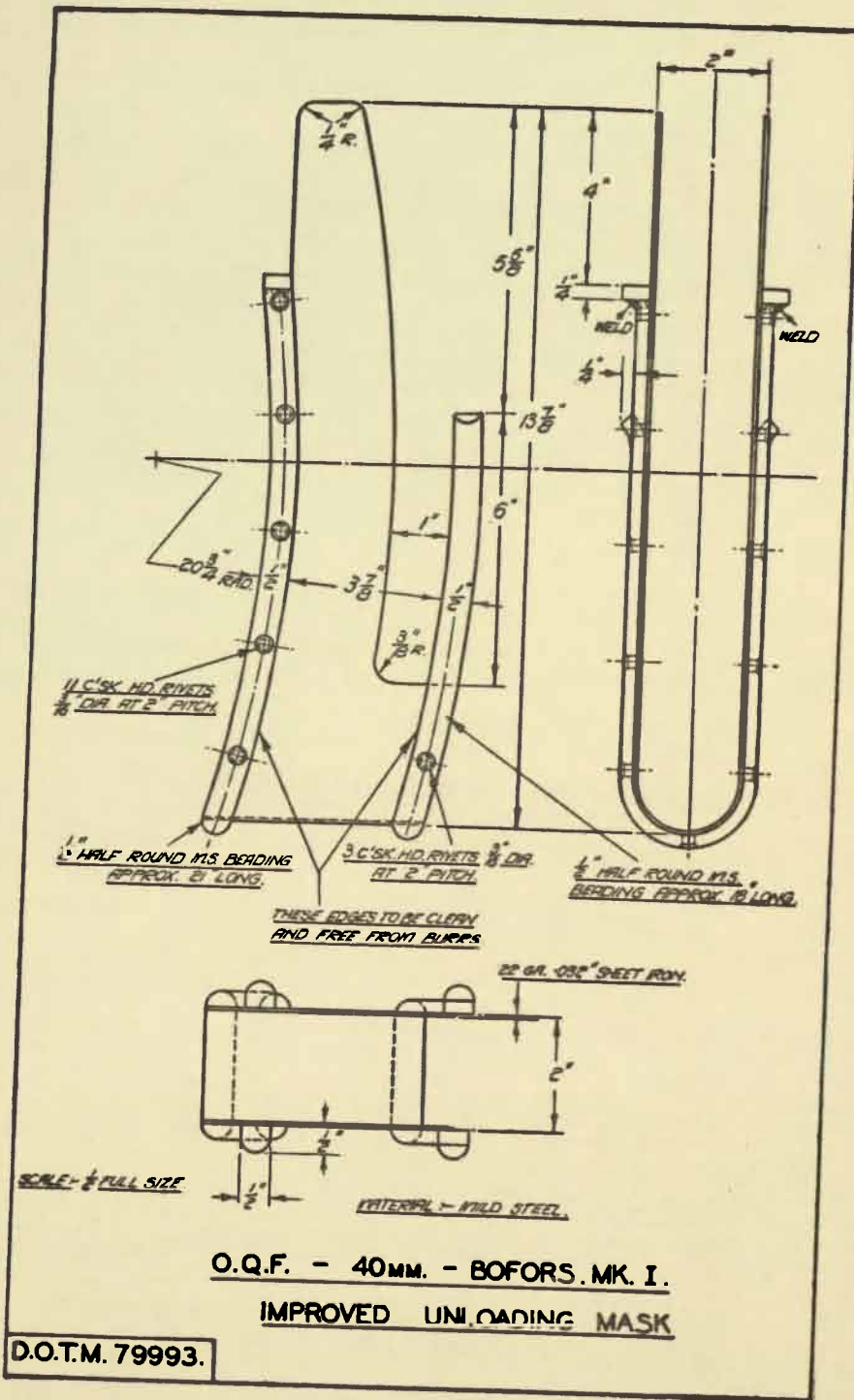

43.

COMPRESSED ASBESTOS FIBRE WASHERS FOR ENGINE ROOM AND BOILER ROOM LIGHTING FITTINGS.

Two new washers, pattern 4200 and pattern 4201 have been introduced for use with engine room and boiler room pendant and bracket lighting fittings.

2. The washers are made of C.A.F. sheet, Admiralty pattern 35, which is a compressed asbestos fibre jointing material, and are to be used in lieu of the rubber washers now fitted for the above-mentioned services.

3. Washers, pattern 4200, are for use with fittings mounted on the obsolete pattern looping-in bases, pattern 9021, and washers, pattern 4201, for use with fittings mounted on looping-in bases pattern 4483.

4. The rubber washers removed from the fittings are to be returned to store.

(532/202/224.)

44.

PAINT, DRY COLOUR—ISSUE OF SHADING PASTE IN LIEU OF.

The issue of paint, dry colour, for use in H.M.A. ships is to be discontinued. In future, shading pastes in the following colours will be supplied in satisfaction of demands for dry colour materials, as per column 5:—

Item.	Denomination.	Colour.	Pattern Number.	Pattern Number of Dry Colour.
1	lb.	Blue, ultramarine	8P	8D
2	"	Green, brunswick	33P	33D
3	"	Chrome, yellow	19P	19D
4	"	Ochre, yellow	52P	52D
5	"	Red, venetian	65P	65D
6	"	Red, permanent	70P	70D
7	"	Red, oxide	111	..
8	"	Brown, vandyke	15P	15D
9	"	Sienna, burnt	75P	75D
10	"	Sienna, raw	76P	76D
11	"	Umber, turkey	81P	81D
12	"	Black in oil	110C	..

2. Weight for weight, the staining intensity of shading pastes is greater than that of dry colour when mixed according to the methods followed in H.M.A. ships and only half the quantity which would be considered necessary when using dry colours should be demanded. The materials shown above will be available from naval store depots. Minimum amounts only should be demanded and the utmost economy in use is to be observed.

(612/233/120.)

45.

THIRD VICTORY LOAN.

The Government desires to emphasize that the success of the forthcoming Third Victory Loan is most important and that subscriptions should be made voluntarily by all sections of the community.

2. Approximately 750,000 of Australia's population are in the Fighting Services and it is desired that every opportunity should be given to them to invest their savings in what is regarded as the best and safest investment in the Commonwealth.

3. Such money invested in War Loans not only bears the highest rate of interest now available but also helps the finances of the country. Bonds and War Savings Certificates are always readily negotiable and provide a valuable addition to deferred pay and other savings which may be required to assist in re-establishment in civil life after the war.

4. Bonds may be purchased outright or by instalments. Approval is given to the use of the allotment system where purchase of bonds by instalments is desired. Similarly, the purchase of War Savings Certificates may be made, *vide* Navy Order 59 of 1941. If you desire to subscribe, ask the Accountant Officer for details.

5. The Third Victory Loan will be open in March.
(552/202/4.)

(This Order will be reprinted for posting on Notice Boards.)

46.

BOOKS AND FORMS.

The under-mentioned form has been adopted for use in the R.A.N. First supply will be made, without demand, by the Superintending Naval Store Officer, Sydney.

S1472—Engine Room Register (For Submarines and Motor Driven Surface Craft).

(A.F.O. 237/44.)

(480/202/4669.)

RESTRICTED.(FOR OFFICIAL USE ONLY.)**Commonwealth Navy Orders.**

Navy Office, Melbourne,
6th February, 1945.

The following Orders, having been approved, are hereby promulgated for information and guidance and necessary action.

By direction of the Naval Board,

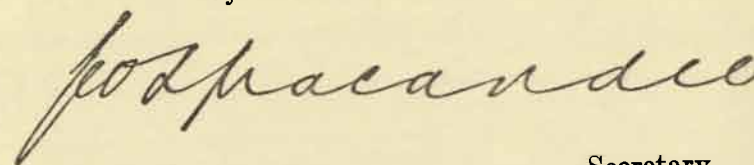

Secretary.

*The Commodore Commanding H.M.A. Squadron,
and Commanding Officers of H.M.A. Ships,
Officers in Charge of H.M.A. Naval
Establishments, and others concerned.*

TABLE OF CONTENTS.

No.	Subject.
47.	R.A.N. Nursing Service—Administration.
48.	Distinction Marks for Wounded (Wound Stripes).
49.	Guns, Machine, 0.303-in. Bren, Mk. I—Exchange of Springs Return.
50.	Annual Inspection of Explosives During 1945.
51.	Cordite Temperature Returns and Sublot Markings—R.A.F.A.'s, Auxiliary A/S and M/S Vessels and M.L.'s.

47.

R.A.N. NURSING SERVICE—ADMINISTRATION.

As the Royal Australian Naval Nursing Service is an integral part of the R.A.N. Medical Service, the Director of Naval Medical Services is responsible to the Naval Board for Administration and Control.

2. The Director of Naval Medical Services will, whenever he considers it necessary, consult with the Matron of the R.A.N. Nursing Service on all matters concerning the organization and administration of that Service as a whole, including the following:—

- (a) All matters of general policy, including questions of general regulations, allowances, uniform regulations, &c.
- (b) All appointments and promotions.
- (c) Applications for leave other than local leave.
- (d) Reports on Nursing Sisters.
- (e) Selection of applicants for entry.
- (f) Mobilization of Nursing Sisters.

3. The attention of all Naval Officers-in-Charge of Establishments where Nursing Sisters are borne is drawn to the necessity of ensuring that any questions affecting the R.A.N. Nursing Service under their command are dealt with in accordance with the above procedure.

(527/204/264.)

48.

DISTINCTION MARKS FOR WOUNDED (WOUND STRIPES).

Members of the Royal Australian Navy, who since the beginning of the present war have been awarded a hurt certificate for a wound sustained through enemy action, may wear a stripe of gold Russia braid, 1½ inches in length, sewn perpendicularly on the left sleeve of the blue coat or blue jumper to indicate each occasion on which the wearer has been wounded. Personnel whose names have appeared on the sick list or in any casualty list as having sustained a "qualifying" wound or other injury (including sequelae of immersion which necessitated hospital treatment, or treatment in a sick bay which, in normal circumstances, would have required treatment in hospital) are similarly entitled to wear a wound stripe.

2. The stripes of braid will be worn by officers on the undress coat only. The lower end of the first stripe will be in the position defined below:—

- (a) Officers who wear distinction lace or braid—on the left sleeve, ½ inch above the curl.
- (b) Officers who do not wear distinction lace or braid—on the left sleeve in the same position as for sub-lieutenants.
- (c) Officers who wear a pilot's, observer's or airgunner's badge—on the left sleeve, ½ inch above the badge.

Members of the Royal Australian Naval Nursing Service should wear the stripes 3 inches from the edge of the left sleeve.

3. Chief petty officers (including Wrans) will wear the gold braid ½ inch above the centre button on the left sleeve. Petty officers and ratings (including Wrans) will wear the gold braid in the middle of the left sleeve with the lower end 3 inches from the bottom of the sleeve.

4. Additional stripes of gold braid marking each subsequent occasion on which the wearer has been wounded will be placed in front of the first stripe at intervals of ½ inch.

5. A wound stripe in red rayon has also been approved. This is to denote receipt of wounds in previous wars, and one such stripe only may be worn in respect of any number of wounds so sustained. It will be worn ½ inch to the rear of the first gold wound stripe.

6. A first issue of two stripes in respect of each qualifying wound is to be made gratuitously, and demands for immediate requirements should be forwarded to the Superintending Victualling Store Officer, Royal Edward Victualling Yard, Sydney, subsequent supplies being obtained as requisite. The articles are to be taken on charge in the clothing account and issues made in the usual manner per Form A.S. 105 suitably amended.

7. The fact that a rating is eligible to wear a wound stripe and that a gratuitous issue has been made should be noted on his service certificate.

8. The grant of a wound stripe does not carry any claim for financial recognition.

(416/201/1072.)

(This Order will be reprinted for posting on Notice Boards.)

49.

GUNS, MACHINE, 0.303-IN. BREN, MK. I—EXCHANGE OF SPRINGS RETURN.

To improve the rate of fire of guns, machine, 0.303-in. Bren, a strengthened return spring in two parts, inner and outer, has been introduced. A.F.O. 1810/44 refers.

2. All single springs return in guns and held as spares are to be exchanged for the new pattern double spring as soon as possible.

3. Ships should forward demands for double springs to the nearest naval armament depot or base. Naval armament depots and bases other than Sydney should demand requirements from the Superintending Armament Supply Officer, Sydney.

4. Single, Mk. I, springs are to be returned to naval armament depots where they are to be kept pending further instructions.

5. Navy Order 185 of 1943 is cancelled.

(612/203/3122.)

50.

ANNUAL INSPECTION OF EXPLOSIVES DURING 1945.

Appended for information and action as necessary is an advance copy of an Admiralty Fleet Order regarding annual inspection and examination of explosives on board H.M. ships and at naval bases for 1945:—

"The Annual Percentage examination and proof of explosives, as laid down in Article 301, Naval Magazine and Explosive Regulations, also the testing of cordite in accordance with Naval Cordite Regulations, are to be carried out during 1945, except as stated in paragraph IV (b).

II. Landing of percentages by H.M. ships is to be deferred where necessary until a port is visited where N.A. depot facilities are available.

III. The complete outfit of explosives on board H.M. ships and in naval air stations and shore bases is to be landed for examination during 1945 (except as stated in paragraph IV (a) where examination is due under Article 300, N.M.E.R., to be carried out during the year.

IV. As regards underwater explosives, the following procedure will be observed:—

(a) *Article 300, N.M.E.R.*—Examination of complete outfit to be observed when due by—

- (i) *H.M. Ships*—but only when the outfit is necessarily landed for some other reason.
- (ii) *Shore Bases and Naval Air Stations*—but to be confined to explosives which have been held for two years or more.

(b) *Article 301, N.M.E.R.*—Percentage examination to be observed by—

- (i) H.M. ships.
- (ii) Shore bases and naval air stations.

Except that return of depth charges under Article 301 (19) should be limited to depth charges which have been more than twelve months on board.

V. As regards paragraph IV (b) above, the percentage landings are to include the following:—

Projectile squid.	} One of each per ship's outfit to be landed.
Squid impulse cartridge.	
Hedgehog projectile.	

VI. Detonation proof of shell will be carried out from those landed under Article 301, instructions in regard to which have already been given to R.N. Armament Depots.”

2. These arrangements are to apply in the Royal Australian Navy.

(471/201/1577.)

51.

**CORDITE TEMPERATURE RETURNS AND SUBLINOT MARKINGS—
R.A.F.A.'s, AUXILIARY A/S AND M/S VESSELS AND M.L.'s.**

Instruction regarding the non-remission of forms S.1147A are contained in Confidential Commonwealth Navy Order 101 of 1943.

2. Navy Orders 316 of 1942, 54 and 131 of 1944 are hereby cancelled.

(471/202/1423.)

By Authority: H. E. DAW, Government Printer, Melbourne.

RESTRICTED.

(FOR OFFICIAL USE ONLY.)

Commonwealth Navy Orders.

Navy Office, Melbourne,
13th February, 1945.

The following Orders, having been approved, are hereby promulgated for information and guidance, and necessary action.

By direction of the Naval Board.

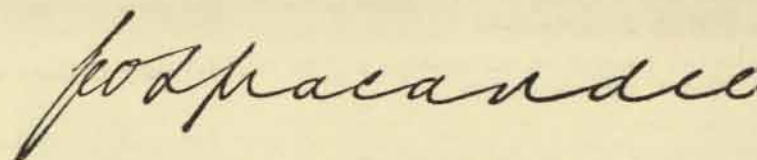

Secretary.

*The Commodore Commanding H.M.A. Squadron,
and Commanding Officers of H.M.A. Ships,
Officers in Charge of H.M.A. Naval
Establishments, and others concerned.*

TABLE OF CONTENTS.

No.	Subject.
52.	Gowrie Scholarships.
53.	H.M.A.S. "Rushcutter"—Organization.
54.	Transfer of Officers having Charge of Naval Stores on Permanent Loan.
55.	Visual Training Instructors.
56.	Clasp to 1939-43 Star.
57.	Single 40 m.m. Bofors Mark IIIA Mountings—Supply of Sights Correctional 40 m.m. A.A. Mtgs. Mk. V (Aust.).
58.	Firefighting Equipment—Life Lines.
59.	Shipment of Mining Stores—Case Markings.
60.	Gas Cylinders—Water Pressure Test.
61.	Precautions to be Observed when Returning Chlorosulphonic Acid Mixture Drums.
62.	Use of Hooks Sling Universal and Slings Rifle.
63.	Alteration and Addition Items.
64.	R.A.N. Women's Auxiliary Services—Special Issue of Coupons for Purchase of Nightwear.

52.

GOWRIE SCHOLARSHIPS.

The trustees of the Gowrie Scholarship Trust Fund, Sir John Latham, Sir Robert Garran, Sir Claude Reading, and Chief Judge H. B. Piper, announce that the fund now amounts to £139,578. The public appeal is closed but further subscriptions will still be accepted. The trustees have now given consideration to the basis for award of scholarships in accordance with the trust deed.

2. The trustees propose to offer annually the following scholarships:—

Two post-graduate research travelling scholarships.

Four university or similar scholarships.

Ten secondary school scholarships.

It is hoped to make the first awards in 1945, to be effective as from 1st January, 1945. Eligible persons are past or present members of the armed and auxiliary forces engaged in the war and their descendants, as defined in the trust deed.

The full number of scholarships will be awarded only if there are candidates of sufficient merit.

3. *Post-graduate Research Scholarships.*—Research travelling scholarships of £A475 per annum will be tenable for two years at universities, &c., abroad.

Nominations for these scholarships may be made by the professorial boards of the Australian Universities. The scholarships will be awarded by the trustees after consideration of recommendations which the university vice chancellors' committee will be invited to make in respect of such nominations.

4. *University and Similar Scholarships.*—Scholarships of £A100 per annum for post-secondary education will be tenable for the normal period of the course desired to be taken at a university or other approved educational institution.

5. *Secondary School Scholarships.*—(a) Scholarships of £A50 per annum will be tenable for two years at secondary schools or such other schools or colleges as the trustees may approve.

(b) No scholarships will be awarded during the compulsory period of education as defined by the laws of the various States except to applicants who have passed an examination of a standard which—

(i) is substantially equal to that of the New South Wales intermediate certificate examination; or

(ii) is such that in normal circumstances the applicant requires only two further years to complete a course of secondary education; or

(iii) is of such other standard as the trustees may approve from time to time.

6. The scholarships which are tenable in Australia at universities, secondary schools, or other educational institutions will be awarded

by the trustees after consideration of recommendations made by such advisory committees in the various States as the trustees appoint for the purpose. Such advisory committees will take into account—

(i) teachers' reports;

(ii) any examination results;

(iii) the character and personality of the candidate;

(iv) the course of education the candidate proposes to complete; and

will report on the financial means of the candidate and his or her parents, if desired by the trustees in any particular case.

Advisory committees will be appointed in each State of the Commonwealth and the Australian Capital Territory to consider applications and to make recommendations for awards to be made by the trustees. For this purpose the trustees will invite the assistance of educationalists and persons interested in the welfare of service personnel, ex-service personnel and their children.

7. The trustees may, in special circumstances, extend the scholarships tenable in Australia for a further period not exceeding one year.

8. The trustees may terminate any scholarship at any time if the trustees are of opinion that the progress or conduct of the holder is unsatisfactory.

9. The number of scholarships to be awarded each year, and the basis of awards may be reviewed from time to time. The number of scholarships to be awarded will depend upon the income earned by the trust fund.

10. Forms of application for scholarships will be forwarded on receipt of a request addressed to—

The Trustees,

The Gowrie Scholarship Trust Fund,

G.P.O. Box 2069,

Sydney, N.S.W.

(474/203/536.)

(This Order will be reprinted for posting on Notice Boards.)

53.

H.M.A.S. "RUSHCUTTER"—ORGANIZATION.

With reference to Navy Order 102 of 1943, the Fairmile School, H.M.A.S. *Rushcutter* was closed as from 11th December, 1944, and the Radar School has been transferred to H.M.A.S. *Watson* (vide Navy Order 38 of 1945).

2. The Anti-Submarine School is still located at H.M.A.S. *Rushcutter*.

3. Navy Order 102 of 1943 is cancelled.

(549/201/94.)

54.

TRANSFER OF OFFICERS HAVING CHARGE OF NAVAL STORES ON PERMANENT LOAN.

Cases have arisen, particularly in the case of motor launches, where officers having charge of naval stores on permanent loan have been transferred before the arrival of the relieving officer and no provision has been made for custody of the stores involved during the interim period.

2. The attention of naval officers-in-charge and commanding officers is directed to Article 52 of the Naval Storekeeping Manual (B.R.4) which sets out the procedure to be adopted when an officer or rating to whom naval stores have been issued on permanent loan is relieved of his particular duties.

3. It is desired that special care be exercised in future to ensure strict compliance with the procedure specified.

(612/212/2898.)

55.

VISUAL TRAINING INSTRUCTORS.

Attention of commanding officers is drawn to A.F.O's. 792/44 and 2975/44 which give details of visual training procedure in the R.N. and which is applicable to the R.A.N.

2. B.R. 873, which is a visual training guide, has been distributed to all ships and establishments supplied with cinema equipment.

3. Application for further information may be made direct to the Director of Training and Staff Requirements Division, Navy Office, Melbourne.

(614/230/15.)

56.

CLASP TO 1939-43 STAR.

Stocks of the silver rose emblem, referred to in paragraph 5 of Navy Order 466 of 1943, are now available to those officers and men who have qualified under the conditions.

2. It should be noted that the only ships of the R.A.N. included in the list of ships specifically engaged in cutting Rommel's or Von Arnim's communications between 23rd October, 1942, and 12th May, 1943, are H.M.A.S. *Quiberon* and H.M.A.S. *Quickmatch*.

3. Applications for the clasps should be forwarded to the Secretary, Naval Board.

(448/201/1578.)

(This Order will be reprinted for posting on Notice Boards.)

57.

SINGLE 40 M.M. BOFORS MARK IIIA MOUNTINGS—SUPPLY OF SIGHTS CORRECTIONAL 40 M.M. A.A. MTGS. MK. V (AUST.).

Arrangements have been made for the supply of sights correctional (stiffkey sticks) to certain ships fitted with single bofors mountings, to replace the eveshooting sights at present fitted.

2. As used by the Army, these sights correctional are arranged so that the aim off is charged in 50 M.P.H. steps, and the rings of eye-shooting sights, which are fitted for use as an alternative, each represent 100 M.P.H. aim off at a range of 1,000 yards.

3. Eight sights have been supplied unmodified; the remainder will be supplied modified for naval use so that the aim off is changed in 50 knot steps and can also be changed in 25 knot steps by pressing the "levers applying speed" half way only. The aim off speed scale has been regraduated in knots.

4. In cases where unmodified sights have been supplied, arrangements have been made for the supply, without demand, of modified racks to give 50 and 25 knot steps as above, together with a new aim off speed scale, graduated in knots, which should be tack soldered over the existing M.P.H. scale.

5. All sights will be supplied with the Army type eyeshooting sights, in which each ring represents 100 M.P.H. aim off. Arrangements are being made for the supply of modification parts, but these will not be available for some time. As a temporary expedient, ships may fit a standard oerlikon foresight grid to the existing sight bar. This will give approximately the correct aim off (in knots) for a range of 2,000 yards. The sight should then be adjusted as follows:—

Tangent elevation at 2,000 yards at 30 deg.—0.55 feet.

Height of rearsight above centre of grid—0.3 inches.

The following instructions for the assembly and adjustment of the sights correctional have been extracted from Australian Military Forces D.M.E. Technical Instruction No. A.103-73.

6. Attention is directed to sub-paragraph (6) of these instructions. *It is most important to see that all locking bolts have been removed before attempting to operate the sight. The locking bolts on the trainers side are particularly liable to be overlooked.*

Items affected—

(i) New Parts.—

Cat. No.	Designation.	Qty./Eqpt.
MBA3603GA ..	Sights, correctional 40 mm. A.A. Mtgs. Mk. V (Aust.)	1

(ii) Discarded Parts.—To be returned to Gunmounting Depot, Garden Island, for storage.

Cat. No.	Designation.	Qty./Eqpt.
AN487A ..	Sights: 40 mm. A.A. Mtgs., Mk. III ..	1

7. Instructions—

(1) The sights correctional Mk. V (Aust.) will be received by units broken down into the following sub-assemblies and attached accessories :—

(i) Main frame assembly to which is attached—

(a) Four hexagon head set screws and spring washers, used for attaching main frame to gun.

(b) Four captive hexagon head set screws in plate at top of stalk tube, used for attaching head correctional assembly.

(c) In the jaws of torque tube are the wing bolts and nuts used for attaching lateral and vertical side bars.

(ii) Lateral and vertical side bar assemblies.

(iii) Head correctional assembly which includes three cheese head captive set screws, used for attaching gate assembly.

(iv) Gate assembly.

(v) Foresights.

(2) The following operations are necessary when installing the above equipment :—

(i) The existing sight either Mks. I, II or III, is to be completely removed from mounting, including existing securing set screws.

(ii) Place main frame assembly in position on mounting and secure with the four set screws and spring washers mentioned in sub-paragraph (a) above.

(iii) Remove wing bolts and wing nuts, mentioned in sub-paragraph (c) above from jaws of torque tube and place lateral and vertical side bars in position, then replace wing bolts.

(iv) Engage all locking handles.

(v) Mount and secure head correctional assembly; this is mounted at top of stalk tube of main frame and is held in position by the four captive hexagon head set screws referred to in sub-paragraph (b) above.

(vi) Mount gate assembly and secure to forward end of head assembly by the three captive cheese head screws referred to in sub-paragraph (1) (iii) above, also adjust and secure to respective side bars.

(vii) Mount foresights in position and tighten wing nuts.

(viii) It will be found that when this sighting unit is mounted, the gun will have a muzzle preponderance and will require re-balancing, this can be achieved by re-adjustment of the counter balance springs.

(3) **Alignment of Sights (Ring Sights).**

(i) Engage all locking handles.

(ii) With the tangent elevation and lateral deflection scales set at zero, proceed with normal drill used in aligning the Mk. II sight.

(iii) Adjustment is to be carried out on *hind sights only*. Provision is made for both vertical and lateral movement of hind sights on both sides.

(4) **Alignment of Head Correctional.**

(i) Disengage all locks.

(ii) With the speed indicator set at zero, and the handle bar of the head correctional revolved through 360 degrees in a vertical plane, the foresights should remain stationary.

(iii) If movement of the foresights is apparent, it is adjusted as follows :—

(a) Slacken off the set screws of the two bearing caps which secure handle bar to head correctional.

(b) Move handle bar longitudinally or radially with respect to bearing until a zero position is obtained, i.e. when handle bar is revolved as in (4) (ii), the foresights remain stationary.

(5) In fitting sights correctional Mk. V (Aust.) to mounting, initial alignment to gun is determined by the fit of the screws securing main frame. Final alignment is carried out as per sub-paragraphs (3) and (4).

(6) It is *most important* that no operation of the head correctional or levers applying speeds be attempted until all locks have been disengaged, otherwise damage to the equipment will occur.

(490/217/22.)

58.

FIRE FIGHTING EQUIPMENT—LIFE LINES.

Recent experience in fire fighting in one of H.M.A. Ships disclosed that hemp life lines, although saturated before use, rapidly dried and became charred when passing over hot steel decks.

2. Commanding officers are to arrange for a $\frac{1}{4}$ -in. flexible steel wire rope fitted with a safety hook at each end to be prepared for use as a life line in the event of fires between decks.

(1873/2/3.)

59.

SHIPMENT OF MINING STORES—CASE MARKINGS.

It has been decided to introduce the following distinctive markings for packages containing mining stores :—

A broad band of blue with the letter "M" superimposed in white on a blue diamond.

2. The above instruction refers to naval armament stores only and not to minesweeping stores or naval stores for controlled mining.

3. Consolidated Orders and Regulations, Article 526, clause 10 (e), will be amended in due course.

4. Navy Order 216 of 1944 is cancelled.

(1924/5/81.)

60.

GAS CYLINDERS—WATER PRESSURE TEST.

The following departmental gas cylinders are due for periodical water pressure test in accordance with Article 310, clause 5, of Engineering Manual (1932) and they are to be returned for testing as early as practicable after the contents are exhausted:—

Oxygen Gas Cylinders—

S.13001, S.13005, S.13010, S.13012, S.13013, S.13014, S.13015,
S.13022, S.13029, S.13036, S.13041, S.13042, S.13043, S.13044,
S.13046, S.13053, S.13054, S.13058, S.13061, S.13064, S.13071,
S.13072, S.13073, S.13074, S.13075, S.13076, S.13077, S.13079,
S.13080, S.13081, S.13083, S.13084, S.13085, S.13088, S.13091,
S.13092, S.13094, S.13098, S.13099, S.13101, S.13103, S.13105,
S.13109, S.13110, S.13111, S.13112, S.13115, S.13116, S.13118,
S.13119, S.13121, S.13123, S.13124, S.13126, S.13128, S.13129,
S.13130, S.13131, S.13132, S.13133, S.13134, S.13136, S.13137,
S.13138, S.13139, S.13140, S.13141, S.13142, S.13143, S.13145,
S.13146.

C.O.₂ Gas Cylinders—

S.13016, S.13023, S.13055, S.13073, S.13081, S.13083, S.13105,
S.13127, S.13131, S.13134, S.13145, S.13146, S.13147, S.13152,
S.13155, S.13158, S.13161, S.13165, S.13170, S.13171, S.13175,
S.13177, S.13178, S.13183, S.13185, S.13186, S.13189, S.13193,
S.13199, S.13201, S.13205, S.13208, S.13210, S.13212, S.13214,
S.13216, S.13224, S.13225, S.13227, S.13228, S.13233, S.13236,
S.13237, S.13238, S.13239, S.13240, S.13241, S.13242, S.13243,
S.13247, S.13249, S.13250, S.13252, S.13253, S.13254, S.13257,
S.13258, S.13260, S.13261, S.13262, S.13269, S.13272, S.13274,
S.13275, S.13279, S.13280, S.13281, S.13282, S.13284, S.13290,
S.13291, S.13292, S.13294, S.13295, S.13296, S.13297, S.13298,
S.13301, S.13303, S.13304, S.13305, S.13315, S.13316, S.13319,
S.13320, S.13322, S.13323, S.13327, S.13331, S.13333, S.13334,
S.13335, S.13336, S.13337, S.13338, S.13340, S.13341, S.13346,
S.13347, S.13348, S.13349, S.13350, S.13351, S.13354, S.13355,
S.13358, S.13359, S.13361, S.13362, S.13367, S.13368, S.13369,
S.13370, S.13372, S.13375, S.13376, S.13377, S.13383, S.13390,
S.13392, S.13394, S.13397, S.13398, S.13400, S.13402, S.13403,
S.13404, S.13405, S.13406, S.13409, S.13413, S.13414, S.13416,
S.13422, S.13424, S.13427, S.13428, S.13429, S.13431, S.13432,
S.13433, S.13434, S.13437, S.13442, S.13443, S.13444, S.13448,
S.13449, S.13450, S.13454, S.13455, S.13460, S.13461, S.13462,
S.13464, S.13466, S.13469, S.13470, S.13472, S.13473, S.13474,
S.13475, S.13476, S.13479, S.13480, S.13482, S.13484, S.13485,
S.13487, S.13488, S.13490, S.13492, S.13493, S.13494.

N.H.3 Gas Cylinders (Ammonia)—

S.13001, S.13002, S.13003, S.13004, S.13008, S.13011, S.13012,
S.13013, S.13015, S.13019, S.13020, S.13021, S.13022, S.13024,
S.13025, S.13026, S.13027, S.13028, S.13030, S.13031, S.13032,
S.13033, S.13034, S.13036, S.13037, S.13038, S.13039, S.13040,
S.13041, S.13042, S.13043, S.13044, S.13045, S.13046, S.13047,
S.13049, S.13050, S.13051, S.13052, S.13054, S.13055, S.13056,
S.13057, S.13058, S.13059, S.13060, S.13062, S.13063, S.13064,
S.13065, S.13066, S.13067, S.13068, S.13069, S.13070, S.13071,
S.13072, S.13073, S.13074, S.13075, S.13076, S.13077, S.13078,
S.13080, S.13081, S.13082, S.13084, S.13085, S.13092, S.13093,
S.13094, S.13095, S.13096, S.13098, S.13099, S.13100, S.13102,
S.13103, S.13104, S.13105, S.13106, S.13107, S.13112, S.13113,
S.13115, S.13119, S.13120, S.13121, S.13123, S.13124, S.13125,
S.13126, S.13132, S.13133, S.13135, S.13147, S.13149, S.13150,
S.13151, S.13152, S.13155, S.13157, S.13159, S.13160, S.13161,
S.13163, S.13164, S.13170, S.13171, S.13172, S.13173, S.13174,
S.13176, S.13177, S.13178, S.13180, S.13181, S.13182, S.13184,
S.13186, S.13187, S.13191, S.13192, S.13193, S.13194, S.13196,
S.13199, S.13200, S.13201, S.13203, S.13204, S.13205, S.13206,
S.13207, S.13209, S.13211, S.13212, S.13214, S.13215, S.13216,
S.13217, S.13218, S.13219, S.13220, S.13222, S.13223, S.13225,
S.13226, S.13227, S.13230, S.13231, S.13232, S.13233, S.13234,
S.13235, S.13236, S.13237, S.13239, S.13243, S.13244, S.13245,
S.13247, S.13249, S.13253, S.13255, S.13256, S.13257, S.13258,
S.13259, S.13260, S.13261, S.13267, S.13268, S.13270, S.13272,
S.13273, S.13275, S.13277, S.13278, S.13279, S.13280, S.13281,
S.13282, S.13283, S.13286, S.13290, S.13292, S.13293, S.13295,
S.13297, S.13299, S.13303, S.13304, S.13306, S.13313, S.13314,
S.13316, S.13317, S.13318, S.13323, S.13324, S.13325, S.13326,
S.13328, S.13330, S.13331, S.13334, S.13336, S.13337, S.13338,
S.13339, S.13340, S.13342, S.13343, S.13344, S.13345, S.13346,
S.13347, S.13349, S.13351, S.13352, S.13353, S.13355, S.13356,
S.13357, S.13359, S.13360, S.13368, S.13370, S.13371, S.13374,
S.13375, S.13378, S.13379, S.13381, S.13383, S.13384, S.13387,
S.13394, S.13395, S.13396, S.13397, S.13399, S.13401, S.13402,
S.13403, S.13404, S.13405, S.13406, S.13411, S.13414, S.13415,
S.13417, S.13419, S.13421, S.13424, S.13426, S.13431, S.13445,
S.13446, S.13447, S.13448, S.13449, S.13450, S.13451, S.13452,
S.13453, S.13454, S.13455, S.13456.

Hydrogen Gas Cylinders—

766919 766920 766922 766923 766924 766925 766926 766927
766928 766929 766930 766931 766932 766933 766934 766935
766937 766938 766939 766940 766943 766944 766945 766947
766949 766950 766951 766952 766953 766954 766955 766956
766957 766958 766959 766960 766961 766963 766964 766966
766967 766968 766969 766970.

2. Establishments should arrange for the necessary tests to be carried out locally where facilities exist for testing and recharging, otherwise the cylinders are to be returned to the nearest naval store depot for necessary action.

3. Particulars of tests carried out by naval establishments are to be furnished to the Naval Officer-in-Charge, Sydney, for insertion in the relevant history sheets of the cylinders.

(669/201/1072.)

61.

**PRECAUTIONS TO BE OBSERVED WHEN RETURNING
CHLOROSULPHONIC ACID MIXTURE DRUMS.**

The attention of all concerned is drawn to the corrosive nature of chlorosulphonic acid mixture and to the fact that a certain amount must inevitably remain in the drum after use.

2. Before returning drums for refilling, therefore, it is essential that the bungs are tightened. In addition to preventing damage through leakage this precaution will ensure that the interior of the drum and the residue of the chlorosulphonic acid mixture are protected from attack by atmospheric moisture.

3. Care should also be taken to ensure that drums are loaded into lorries, railway waggons, &c., bung upwards.

(421/201/970.)

62.

USE OF HOOKS SLING UNIVERSAL AND SLINGS RIFLE.

Stocks of slings Thompson sub-machine gun are nearing exhaustion, and no further supplies can be obtained.

2. The sling rifle can be used for all types of sub-machine guns when used with a hook sling universal. Supplies of these hooks will shortly be to hand.

3. Naval armament depots are to demand their requirements of these hooks from Superintending Armament Supply Officer, Sydney, and ships and bases are to demand from the nearest naval armament depot.

(402/201/230.)

63.

ALTERATION AND ADDITION ITEMS.

In future, ships are to forward a copy of all proposals for alteration and addition items to their refitting authorities in order that the remarks and recommendations of dockyard officers or base staff may be forwarded as early as practicable to the Naval Board.

(603/247/1868.)

64.

**R.A.N. WOMEN'S AUXILIARY SERVICES—SPECIAL ISSUE OF
COUPONS FOR PURCHASE OF NIGHTWEAR.**

A special issue of clothing coupons, sufficient for the purchase of one or two sets of nightwear (pyjamas and nightgown) may be granted to a member of the R.A.N. Women's Auxiliary Services, who—

(a) is transferred from one extreme of climate to another, or

(b) is serving in an area where winter-type nightwear is essential but who, prior to her present allocation, lived in a district where nightwear of that type was not necessary,

and who does not possess at least two sets of the type of nightwear required for her new area of service.

2. This special issue will be in addition to the annual maintenance issue and will be subject to the following:—

(a) The commanding officer of the establishment concerned shall, after consultation with the senior representative present of the Women's Service of which the applicant is a member, determine whether the allotment of coupons is essential, having particular regard to the acute shortage of civilian clothing stocks.

(b) The issue shall be authorized only when the member does not possess at least two sets of the type of nightwear required, and does not possess sufficient coupons to effect purchase.

(c) The application, if approved by the commanding officer, shall be transmitted by the commanding officer to the Deputy Director of Rationing in the State concerned, and is to include the following information:—

(i) Name, rank or rating (official number where applicable).

(ii) Address for issue of special permit.

(iii) Number and type of garments to be purchased, i.e., nightdresses or pyjamas, and whether the articles required have short, long, or no sleeves; also, in the case of "tropical" pyjamas, whether trousers with legs of less than knee length are required.

(d) The member shall produce the garment or garments purchased and the relative invoice for the inspection of the representative referred to in paragraph 2 (a) above.

(e) A detailed record is to be maintained of all such special coupon issues.

(f) A statement of the special coupon issues is to be rendered to the Director of Victualling at the end of each calendar month.

(g) Not more than one such coupon issue is to be made to a member in any one rationing year.

3. This "special issue" will be operative as from 1st January, 1945.

(350/201/79.)

RESTRICTED.(FOR OFFICIAL USE ONLY.)

Commonwealth Navy Order.

Navy Office, Melbourne,

20th February, 1945.

The following Orders, having been approved, are hereby promulgated for information and guidance, and necessary action.

By direction of the Naval Board,

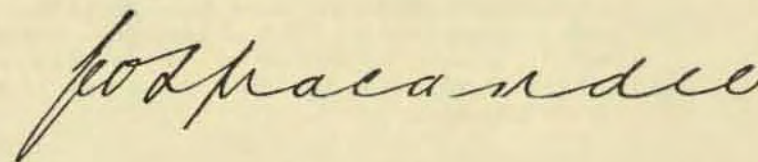

Secretary.

*The Commodore Commanding H.M.A. Squadron,
and Commanding Officers of H.M.A. Ships,
Officers in Charge of H.M.A. Naval
Establishments, and others concerned.*

TABLE OF CONTENTS.

No.	Subject.
65.	Bursaries for Children of Personnel Killed or Disabled during the Present War.
66.	A.M.S. Vessels' Magazines—Battens—Reports.
67.	O.Q.F. 40-mm. Bofors—Series Inspection.
68.	Preservation of Shells B.L. or Q.F.
69.	Depth Charges—Plugs Wood Primer Tube.
70.	Boxes Ammunition C.222 and C.199.
71.	Boxes W.76 and W.76E.
72.	Test Lamps for Domestic Automatic Refrigerators.
73.	Distribution of Booklet "Legal Assistance to Members of the Forces."
74.	Return of Training Films and Film Strips held on Board.
75.	Books and Forms.
	C.1718/45.

65.

BURSARIES FOR CHILDREN OF PERSONNEL KILLED OR DISABLED DURING THE PRESENT WAR.

The King George's Fund for Sailors has established a fund by which twenty bursaries tenable at public schools in New South Wales are to be made available each year to children of naval personnel killed or disabled in this war. (A public school does not mean a State school.)

2. Each bursary will be to the value of £25 per annum and will be awarded under the following conditions:—

- (a) Tenable for three years subject to satisfactory term reports from the headmaster or headmistress of the school.
- (b) Bursaries can be continued after three years subject to the approval of the principal.
- (c) They are to be known as the "King George's Fund for Sailors' Bursaries" and are open to boys and girls whose fathers may have been killed or disabled in this war.
- (d) Application for a bursary should be made through the headmaster or headmistress at the school at which the boy or girl is attending, or intends to attend. The principal of the school must certify that the candidate is a desirable candidate from the educational angle. Such applications should be sent to the Naval Staff Office, Potts Point, Sydney, marked "School Bursaries," and should be in the hands of the receiving authority by 15th January.
- (e) Candidates should not be less than fourteen years of age as at 1st February.

3. *Children under fourteen years.*

The fund will be glad to assist financially in the education of boys and girls under the age of fourteen. Application for such assistance should be made in the same manner as for older children.

4. *State Schools*

There being no fees payable at State schools, bursaries will not be tenable at them. The fund will be glad to assist with grants for books, &c., where approved by the headmaster or headmistress.

5. The choosing of the final twenty to be awarded will be made by the Naval Officer-in-Charge, Sydney, in conjunction with the committee of the King George's Fund for Sailors.

(552/201/1250.)

(This Order will be reprinted for posting on Notice Boards.)

66.

A.M.S. VESSELS' MAGAZINES—BATTENS—REPORTS.

It is believed that battens in the magazines of A.M.S. Vessels do not always conform to the standard dimension of 3-in. x 2-in. section.

2. Ships are to report—

- (a) The sizes of battens fitted.
- (b) If any trouble has been experienced by battens breaking.

(603/267/1577.)

67.

O.Q.F. 40 MM. BOFORS—SERIES INSPECTION.

B.R. 291, table C, lays down that a 40-mm. bofors barrel is to be inspected after firing 300 equivalent full charges since last inspection. Navy Order 578 of 1944 states that rounds filled W., W.T., or W.M.T. cordite are to be assessed as 5 E.F.C. The effect of this is that, when firing ammunition filled W., W.T., or W.M.T. cordite, barrels must at present be inspected every 60 rounds.

2. As this small inspection series is likely to prove inconvenient, it has been decided that 40-mm. bofors barrels in H.M.A. ships and establishments are in future to be inspected when they have fired, since last inspection, 300 E.F.C. or 150 rounds, whichever permits the greater number of rounds to be fired.

3. A pencil note "See Navy Order 67 of 1945" is to be inserted in B.R. 291, table C.

(490/212/1242.)

68.

PRESERVATION OF SHELLS B.L. OR Q.F.

It is desired to draw the attention of all concerned with the storage and issue of shells B.L. or Q.F. to the tendency for these stores to rust, particularly in the wetter or more humid weather experienced in northern operational areas.

2. Care is to be taken therefore that the provisions of Article 666 of Regulations for Naval Armament Services Part I (O.U.5407A) are fully observed.

(408/204/2390.)

69.

DEPTH CHARGES—PLUGS WOOD PRIMER TUBE.

Reports have been received that depth charges are being received in forward areas without the plugs wood primer tube fitted. These plugs have apparently become loose and fallen out or are not replaced after removal on board ships, &c.

2. In this connection attention is drawn to Navy Order 165 of 1944. Demands are to be rendered as necessary for bungs required.

(471/205/2105.)

70.

BOXES AMMUNITION C.222 AND C.199.

With reference to Navy Order 278 of 1944, it is desired to make clear that Q.F. 4-in. Mark XVI* gun ammunition for despatch to armament store issuing ships must not be packed in boxes C.222 unless direct shipment is assured.

(421/202/799.)

71.

BOXES W.76 AND W.76E.

It has been reported that blocks T.N.T. 1½ lb. packed in boxes W.76E, i.e., boxes without metal linings, have been affected by moisture after storage in forward areas. In a number of cases, the wrappers of the blocks have rotted.

2. In order to avoid this deterioration, blocks T.N.T. 1½ lb. for supply to northern areas are to be packed in boxes W.76 as far as possible, blocks being repacked as necessary.

3. In order to implement this arrangement, all empty boxes W.76 held at outports are to be returned at the first opportunity to the Superintending Armament Supply Officer, Sydney.

(666/206/1031.)

72.

TEST LAMPS FOR DOMESTIC AUTOMATIC REFRIGERATORS.

Navy Order 488 of 1944 regarding the use of a halide lamp for detecting leaks in domestic automatic refrigerators is hereby cancelled. In this connection, attention is drawn to A.F.O. 200/44.

2. The provisions of A.F.O. 4012/44 concerning the use of a lamp for testing leaks in Freon-operated refrigerators are not to apply to the R.A.N. A halide test lamp will not be allowed for use in H.M.A. ships and bases.

(524/201/2600.)

73.

DISTRIBUTION OF BOOKLET "LEGAL ASSISTANCE TO MEMBERS OF THE FORCES".

With reference to Navy Order 629 of 1944, paragraph 2, the booklet "Legal Assistance to Members of the Forces", prepared by the Attorney-General's Department, is in course of distribution to the Naval Forces.

2. Bundles of the booklets are being dispatched from Navy Office to ships and establishments, and commanding officers are to ensure that a copy is given to each member of the Naval Forces (including the Women's Services) under their command.

(571/201/4419.)

74.

RETURN OF TRAINING FILMS AND FILM STRIPS HELD ON BOARD.

All ships and shore establishments are to furnish direct to the Naval Board returns of training films and film strips held.

2. The following details are required:—

Serial Nos.	Title	Number of Parts.	Condition.
-------------	-------	------------------	------------

3. Film strips are to be listed separately giving serial number and title.

(560/203/28.)

75.

BOOKS AND FORMS.

First supplies of the under-mentioned publications have been distributed. Further supplies of B.R. Form U2D, B.R.'s. 811 Series 1030 and 1075 are being obtained to complete distribution:—

B.R. Form U2D.—Regulation for the Security of Top Secret, Secret, Confidential and Restricted Books, Documents and Charts.

(A.F.O. 5593/44.)
(480/201/3444.)

Amendment No. 5 to B.R.150.—Manual of Aircraft Recognition.

(A.F.O. 3891/44.)
(571/202/1646.)

A.B.R.170.—Drill for the Bofors Mark I Gun on Mark IIIA Mounting.

A.B.R.171.—Handbook for the Bofors Mark I Gun on Mark IIIA Mounting.

(571/202/2087.)

B.R.222.—Notes on W/T Sets—Additional Pages—AA7 and 21 to R.A.182.

(A.F.O. 3223/44.)
(571/202/1841.)

B.R.367/1943.—Anchors, Chain Cables, &c., Pages 1-36 and Plates 1 and 2.

(A.F.O. 2674/44.)
(571/202/1715.)

Errata No. 12 to B.R.368 and Form D.129.—Establishment of Naval Stores for Sloops, Corvettes ("Kittiwake", &c., types), &c., and Form D.129. List of Particulars.

(A.F.O. 3461/44.)
(571/202/1548.)

B.R.'s.510/1943.—Geographical Handbook Series—Naval Intelligence Division, "Indo China".

B.R.519A/1943.—Geographical Handbook Series—Pacific Islands, Volume II, Eastern Pacific.

(A.F.O. 1888/44.)
(571/202/2053.)

B.R.640 (2).—Combined Operations Pamphlets: Beach Organization and Maintenance.

(A.F.O. 2803/44.)

B.R.640 (6A).—Military Communication in Combined Operations.

(A.F.O. 2276/44.)

B.R.640 (7B).—S.P. Artillery.

(A.F.O. 1428/44.)

- B.R.640 (14E).—R/T Procedure (Revised).
(A.F.O. 889/44.)
- B.R.640 (41c).—R.E.M.E.—Waterproofing of Vehicles and Equipment.
(A.F.O. 3767/44.)
(571/202/1837.)
- B.R.753/1944.—Foreign Office List, 1944.
(571/202/2070.)
- B.R.811.—Aircraft Torpedo Manual Pamphlets (1B), (1c), (1D), (1E) and (1F).
(A.F.O. 5232/44.)
(571/202/2046.)
- B.R.847 (1) (Late C.B.4302).—Addendum No. 1 to Handbook for the 2 pdr. Mark VIII Gun on the Mark VII and VII* P Mountings for Mountings fitted with B.P.50/1943.
(A.F.O. 4826/44.)
(571/202/1951.)
- Addendum No. 1 to B.R. 853.—Oiling at Sea by Buoyant and Rubber Hose.
(A.F.O. 2015/44.)
(571/202/1805.)
- B.R.855/43.—Handbook of Mark V* Oropesa Sweep.
(A.F.O. 5024/44.)
(571/202/1848.)
- B.R.860 (5).—Block Sketch Cards—British and Foreign Warships—New Card No. 14.
(A.F.O. 5599/44.)
(571/202/1921.)
- B.R.980 (X).—R.T. No. 581 for Q.F. 4·5-in. Guns, Marks I, III and IV—April, 1944.
(A.F.O. 4178/44.)
- B.R.980 (B).—R.T. No. 591, Pages 1-5, May, 1944.
B.R.980 (X).—R.T. No. 590, Pages 1-5, May, 1944.
(571/202/1897.)
- B.R.1007 (Form S.1568).—Pamphlet on Night Vision and Illustrated Poster.
(A.F.O. 3139/44.)
(571/202/2028.)
- B.R. 1020/1944 (Superseding C.A.F.O.S.404/43).—Aircraft Practices Code.
(571/202/2077.)
- B.R.1030.—Preliminary Pamphlet for the Q.F. 17 pdr. Mark III and Q.F. 25 pdr. Mark II Guns on the Mark I (N) Mounting.
(A.F.O. 3218/44.)
(571/202/2027.)

- B.R.1048.—Handbook of Dip Curves of Enemy Moored Mines and Obstructors.
(A.F.O. 5232/44.)
(571/202/2072.)
- B.R.1050B/1944.—The Fishing Craft and Fisheries of Hong Kong.
(A.F.O. 5232/44.)
(571/202/2078.)
- B.R.1054/1944.—Drill for the Fuzekeeping Clock Mark II* and II** and Admiralty Fire Control Clock Mark I and I*.
(A.F.O. 3085/44.)
(571/202/2023.)
- B.R.1075/1944.—Drill for Pom Pom Director, Mark IV.
(A.F.O. 3771/44.)
(571/202/2032.)
- B.R.1084/1944.—Provisional Drill for 17 pdr. Gun Mark III on the Marks I and II (N) Mounting.
(A.F.O. 4318/44.)
(571/202/2051.)
- O.U.5292.—Block Sketch Cards of British Warships—Cards 1, 5, 8, 14, 15, 16A, 18D, 18E, 18F, 18G, 19A, 20, 21, 23, 26, 27, 28 and 36A.
(A.F.O. 4882/43.)
(571/203/2354.)
- Errata No. 15 to O.U.5365 (A).—Priced Vocabulary of Naval Armament Stores, Part I.
Errata No. 20 to O.U.5365 (B).—Priced Vocabulary of Naval Armament Stores, Part II.
Errata No. 2 to O.U.5365 (E).—Priced Vocabulary of Naval Armament Stores, Part V.
(A.F.O. 3223/44.)
- Errata No. 15 to O.U.5365 (C).—Priced Vocabulary of Naval Armament Stores, Part III.
(A.F.O. 5232/44.)
(571/203/2552.)
- O.U.6353.—British Merchant Vessels Lost from Outbreak of War—June and July Supplements and Amendments.
O.U.6353A.—Foreign Merchant Vessels Sunk and Damaged by the Enemy from Outbreak of War—June and July Supplements and Amendments.
(A.F.O. 5599/44.)
(571/203/2460.)
- Aircraft Recognition Journal Volume II, Nos. 11 and 12.
(A.F.O. 4427/44.)
(415/201/1879.)
- Army Training Memorandum (War) (Australia) No. 37.
(546/201/113.)

2. The following books are cancelled and all copies are to be disposed of in accordance with the instructions contained in Form B.R.1:—

B.R.317 (4).—Mining Drill Book—Preparation of the Mark XIX Mine.

B.R.317 (5).—Mining Drill Book—Preparation of the Mark XIXS Mine Asy. No. 1.

B.R.317 (13).—Mining Drill Book—Preparation of the Mark XXI Sinker Asy. No. 1.

B.R.317 (15).—Mining Drill Book—Preparation of the Mark XVI Mine Asy. Nos. 5 and 6, and the Mark XVI Sinker Asy. Nos. 1, 2, 3, 7.

B.R.317 (21).—Mining Drill Book—Preparation of the Mark XIXS Mine Asy. No. 2.

(A.F.O. 5230/44.)
(571/202/1970.)

B.R.993.—Handbook of the Mark XXI Sinker.

(A.F.O. 5230/44.)
(571/202/1914.)

B.R.107.—Defence of Fishing Vessels—Owners' and Skippers' Handbook—being obsolescent has been deleted from B.R.1.

(A.F.O. 5702/44.)
(571/202/1576.)

B.R.732/1940.—Instructions for the Disposal of Mines washed or brought ashore, was rendered obsolete on the issue of C.B. (R) 3116 (2).

(A.F.O. 5102/44.)
(571/202/1590.)

3. The under-mentioned form has been introduced for use in the R.A.N. First supply will be made without demand by the Superintending Naval Store Officer, Sydney:—

S.1575.—Regulations for Watertight Openings.

(A.F.O. 3088/44.)
(480/202/4639.)

4. The under-mentioned form has been adopted for use in the R.A.N. in lieu of the corresponding Admiralty form. First supply will be made, without demand, by the Superintending Naval Store Officer, Sydney:—

A.D.513.—Precautions to be taken in selection and use of Hemp Ropes.

(A.F.O. 4236/43.)
(480/201/3265.)

A.S.1566.—Register of C.B's. and S.P's. held in Minor War Vessels and Submarines.

(C.A.F.O. 1562/1944.)
(480/202/4628.)

RESTRICTED.

(FOR OFFICIAL USE ONLY.)

Commonwealth Navy Orders.

Navy Office, Melbourne,
27th February, 1945.

The following Orders, having been approved, are hereby promulgated for information and guidance and necessary action.

By direction of the Naval Board,

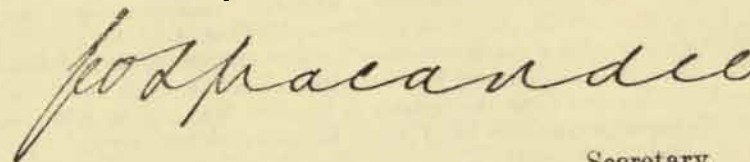

Secretary.

*The Commodore Commanding H.M.A. Squadron,
and Commanding Officers of H.M.A. Ships,
Officers in Charge of H.M.A. Naval
Establishments, and others concerned.*

TABLE OF CONTENTS.

No.	Subject.
76.	Marriage and Child Allowance—Sterling Payments.
77.	Coastal Craft Section.
78.	Examination of Sick Berth Staff—November, 1944—Results.
79.	Care of Anti-Gas Respirators.
80.	Leather Sea Boots—Economy.
81.	Supply of Bottled Beer to H.M.A. Ships and Naval Establishments in the New Guinea Area.
82.	Naval Personnel Proceeding on Leave or Discharged—Supply of Cigarettes and Tobacco.

76.

MARRIAGE AND CHILD ALLOWANCES—STERLING PAYMENTS.

Under a pre-war arrangement with the Treasury, approval was given for payment of personnel serving abroad to be made in sterling subject to the proviso that allotments payable in Australia would be charged at par.

Technically, marriage allowance was a credit to the account of the rating and where, in relatively few instances, there were allotments payable in England, they were paid in sterling at par.

2. As a war measure, the rates of marriage and child allowances have been considerably increased. The accounts of the other Services (Army and Air), wherever they may be, are kept in Australian currency, and, when members are serving abroad, they receive a further credit adjusting part only of their pay to sterling equivalent.

The R.A.N., however, has carried on under the old conditions, and the whole of the credits of personnel serving abroad have been treated as sterling, insofar as payments abroad are concerned, irrespective of whether they were "over the counter" or "by allotment."

3. An anomalous position arises also in that, when a rating is returned to Australia and leaves his wife and family at home, the whole of his credits are in Australian currency. Should he be allotting considerably more than the minimum requisite allotment, he is faced either with meeting the difference between Australian currency and his current sterling allotment from the residue of his own drawings or with reducing the allotment payable in the United Kingdom to the sterling equivalent of Australian currency.

4. The question has been raised as to the authority for payment of marriage allowance in sterling as, under the terms of the approval, these were payments to be made direct to the wives or in respect of children (as distinct from credits to the member).

5. It is realized that hardship may arise if such credits were reduced to Australian equivalent in respect of allotments now in force in the United Kingdom, and special approval has been obtained for continuance of present procedure in respect of existing allotments, subject to the following:—

Increases in child allowances for children born subsequent to 31st March, 1945, or credit of marriage and child allowances in respect of marriages contracted subsequent to 31st March, 1945, will be made in Australian currency. It will thus be necessary to credit the new marriage and child allowances at the sterling equivalent of the Australian rates whilst allottee and allottee both remain abroad.

6. In dealing with ledger accounts of personnel affected by the above, the attention of accountant officers is drawn to the following:—

(a) Should an allottee at present being credited with the full rates of marriage and child allowances in sterling remain abroad, but his wife take up residence in Australia, he will continue to be credited with such rates, on the allotment being re-declared payable in Australia.

(b) An allottee marrying subsequent to the 31st March, 1945, remaining abroad, whose wife subsequently takes up residence in Australia, will be credited with the full rates of marriage and child allowances in sterling from the beginning of the pay period from which the Australian allotment commences.

(It will be seen that these ledger credits abroad at (a) and (b) are in effect made in sterling at par and the identical amounts are paid by way of allotment in Australia in Australian currency. Thus the member will receive no benefit by way of exchange.)

(c) An allottee in receipt of the reduced sterling rates of marriage and child allowances, returning to Australia, whose wife remains abroad, will be credited with the full approved rates of such allowances in Australian currency from the date of receipt of pay in Australian currency. In these cases, transfer lists should clearly indicate that the rates of marriage and child allowance are to be increased to the Australian currency equivalent from date of the member's return to Australia.

(d) An allottee, in receipt of full rates of allowances in sterling, returning to Australia and reverting to pay in Australian currency and subsequently going abroad (his wife being still abroad), will be credited with marriage and child allowances at the reduced rates in sterling from the date of receipt of pay in sterling.

(556/207/5316.)

77.

COASTAL CRAFT SECTION.

The under-mentioned amendments are to be made in the list of craft comprising the coastal craft section shown in Navy Order 652 of 1944:—

(a) Add—

<i>Ayesha</i>	<i>Karina</i>	<i>Potrero</i>
<i>Bliss</i>	<i>Mako</i>	<i>River Snake</i>
<i>Grass Snake</i>	<i>Nami</i>	<i>Stella</i>
<i>Jon Jim</i>	<i>Nova</i>	<i>Sleuth</i>
<i>Jurien</i>	<i>Polaris</i>	<i>Tringa</i>

(b) Delete—

<i>Angler</i>	<i>Kiara</i>	<i>Marietta</i>
<i>Ambon</i>	<i>Kweena</i>	<i>M.L. 827</i>
<i>Arthur Rose</i>	<i>Ladava</i>	<i>Red Bill</i>
<i>Chinampa</i>	<i>Larrakia</i>	<i>Seafarer</i>
<i>Coongoola</i>	<i>Moruya</i>	<i>Westwind</i>
<i>Fauro Chief</i>	<i>Miss Swan</i>	<i>Wai Marie</i>
<i>Killearn</i>	<i>Malanda</i>	
<i>Kuru</i>	<i>Marlean</i>	

(c) *Iris* is to be amended to read *Ibis*.

(1937/2/279.)

EXAMINATION OF SICK BERTH STAFF—NOVEMBER, 1944—RESULTS.

The results obtained by candidates who passed in the examination for advancement in the Sick Berth Branch, held on 21st November, 1944, are as given hereunder:

Examination Number.	Name.	Present Rating.	O.N.	Percentage of Marks obtained at Examination.				Approximate Percentage for (a) Written, and (b) Oral and Practical.	Where Serving at Time of Examination.
				Paper No. 1.	Paper No. 2.	Written (Average Percentage).	Oral and Practical.		
51	Faryghar, A. H.	..	20418	78	75	70.5	70	73	Westralia
22	Titheridge, E.	..	PM2091	75	63	69	71	70	Ruscheuter
23	Van Emden, S. J.	..	24237	70	70	70	80	75	"
60	Cope, F. J.	..	PA2095	78	75	70.5	90	83	Cerberus
63	Butler, M. E.	..	WR1724	85	85	85	70	77	"
64	Irving, P.	..	WR707	70	70	70	75	72	"
79	Collier, A. J.	..	PM2102	72	68	70	70	70	Shropshire
7	Suess, R. W. T.	..	B3164	89	77	83	62	72	Quickemah
13	Thasicker, L. G.	..	F4833	74	66	70	50	60	Mcville
14	Maurier, K. G.	..	S7847	69	71	70	60	60	"
15	Aylen, J. B.	..	PA3515	70	77	75.5	80	78	Ruscheuter
24	Dozenu, D. J.	..	84880	70	76	73	66	60	"
25	Techorne, L. M.	..	89283	66	57	61.5	58	60	Inverell
49	Baird, G.	..	PA1881	50	50	50	70	60	Cerberus
56	Walkate, B. W.	..	PM6832	82	86	84	82	83	"
58	Goodman, J. E.	..	H1541	66	64	65	55	60	"
61	Kelly, C. A.	..	WR485	65	65	65	75	70	"
62	Sheehan, L. L.	..	WR1221	73	73	73	75	74	"
65	Rahilly, A. I.	..	WR1104	85	85	85	50	67	"
80	Hushell, C. L.	..	F3622	77	85	81	68	74	Australis
81	Andrew, A. H.	..	PM4164	70	73	71.5	75	73	Gentiana
87	Hoysted, J. D.	..	21960	61	72	66.5	56	61	Barcoo

2. The marks obtained by candidates who failed have been communicated to the commanding officer of the ship or establishment in which the rating was serving at time of the examination.

3. Papers from overseas vessels have, in some cases, not yet been received. If any examination papers should be forthcoming later, the results thereof will be published as soon as practicable.

4. The 21st November, 1944, is to be regarded as the basic date for the passing of this examination.

5. The original copies of Forms A.S. 1236 and A.S. 1237 have been completed and forwarded to the ships and establishments concerned. Duplicate copies have been forwarded to the Naval Officer-in-Charge, Flinders Naval Depot. The necessary notation should be made on the Service certificates of candidates.

(This Order will be reprinted for posting on Notice Boards.)

(465/207 952.)

79.

CARE OF ANTI-GAS RESPIRATORS.

The attention of all concerned is to be drawn to the fact that anti-gas respirators are the personal responsibility of the officers or ratings to whom issued and are to be carried on their persons when travelling and not stowed in luggage compartments.

2. This instruction is applicable when personnel are travelling by air.

(669/201/1100.)

80.

LEATHER SEA BOOTS—ECONOMY.

The following provisions of A.F.O. 4808/44 are brought to the notice of all concerned:—

"Leather sea boots are frequently returned to the victualling yards in a condition which necessitates scrapping sooner than should be necessary. These boots are not only costly but their production requires specially skilled labour and uses material which is already scarce.

2. If sea boots are not properly cared for, the leather soon deteriorates and they become hard and uncomfortable to wear. To prevent this, they should be regularly treated with dubbin or other suitable grease both while in store and in use; dubbin for the purpose can be demanded from the victualling yards. Sea boots that are not in use should be kept clean and if they become wet they should be dried slowly.

3. It is also essential that sea boots which become worn should be returned to a victualling yard while still in a repairable condition. The extent to which repairs can be executed is necessarily limited to replacement of the outer sole or heel and to minor restitching or patching. Boots should not, therefore, be worn down below the outer sole. If the leather should become hardened, the boots should be bumped out with paper to their proper shape and the leather revived by a generous use of dubbin or grease.

4. Sea boots returned to victualling yards should be tied together in pairs."

(434/214/610.)

81.

SUPPLY OF BOTTLED BEER TO H.M.A. SHIPS AND NAVAL ESTABLISHMENTS IN THE NEW GUINEA AREA.

With reference to Navy Order 538 of 1944, the prevailing conditions necessitate, in order to ensure a regular supply of beer to naval personnel in the New Guinea area, more especially to tenders, that beer be carried in H.M.A.S. *Wilcannia* in future for issue on repayment to such H.M.A. ships and to bases on shore.

2. Issues from *Wilcannia* will be made in complete cases under the general direction of the Naval Officer-in-Charge, New Guinea, and will be confined to the current A.M.F. ration for the New Guinea area, viz., two bottles per head weekly, up to one month's estimated requirements being issued in bulk, if desired, to each ship or base which can provide satisfactory storage for that quantity.

3. The authorized issuing price of case supplies from *Wilcannia* is 1s. 3d. per bottle, less 8½ per cent., and the issuing price to individual messes or ratings is to be maintained at the ruling Australian Army Canteens Service rate in New Guinea, at present 1s. 3d. per bottle. The 8½ per cent. discount for case supplies is the equivalent of 5 per cent. discount normally allowed by the Australian Army Canteens Service at time of purchase, plus two thirds of the 5 per cent. monthly profit distribution. The canteen funds of each ship or base will thus benefit from sales ex *Wilcannia* to the same extent as if supply had been obtained from Australian Army Canteens Service sources.

4. In order to ensure that available stocks of beer in the New Guinea area are equitably distributed between the personnel of all Services, it is important that consumption in individual ships and shore bases from all sources does not exceed the authorized allowance of two bottles per head per week. The commanding officers of ships and bases, which obtain their full authorized supply of beer for a specified period from *Wilcannia*, in accordance with paragraph 2 above, should, therefore, take such precautions as are considered necessary during the period concerned to prevent encroachment upon stocks held by the Australian Army Canteens Service, with the object of maintaining the equitable distribution desired.

5. It is imperative, if the continued supply of beer ex *Wilcannia* is to be ensured, that all empty bottles should be preserved to the utmost extent and securely re-packed in the original cases, together with the straw or fibre envelopes, for return to *Wilcannia* on the next succeeding visit at the latest. To enable this procedure to be effected satisfactorily for delivery in due course to the brewers, all cases should be carefully opened to avoid damage. The extreme shortage of all such materials in Australia renders this course essential owing to the heavy drain on local resources to cope with regular shipments to the armed forces. Shipment of empty bottles should also be arranged, when possible, in other store ships or store carriers proceeding to Brisbane or Sydney, but, in such instances, the Superintending Victualling Store Officer or Victualling Store Officer at the port concerned should be advised on each occasion in order that collection from the ship and eventual return to the brewers may be arranged.

6. All profits resulting from bulk sales of beer by H.M.A.S. *Wilcannia* are paid to the credit of the R.A.N. Central Canteen Fund—see Navy Order 484 of 1944, Section D—after the completion of each voyage.

(668/202/235.)

82.

**NAVAL PERSONNEL PROCEEDING ON LEAVE OR DISCHARGED—
SUPPLY OF CIGARETTES AND TOBACCO.**

The following approved arrangements for the supply of cigarettes and tobacco to naval personnel proceeding on long leave, and to personnel discharged to civil life, are promulgated for general information:—

(a) Personnel proceeding on long leave.

Personnel proceeding on leave may be supplied with cigarettes or tobacco in the ship or establishment in which they are

borne during the period of their leave, such supply to be calculated on a maximum issue of 105 cigarettes or 3 ounces tobacco per head per week.

(b) Personnel discharged to civil life.

- (i) Discharged naval personnel may, on application to the chairman of the Tobacco Distribution Committee in any State, arrange to secure a weekly quantity of cigarettes or tobacco from a retail tobacconist whom they nominate. Such ration does not normally operate until one month after application is made.
- (ii) To cover the period between the date of a member's discharge and the date when supplies are made available through a retail tobacconist, personnel may draw, on discharge, up to 24 days' supply of cigarettes or tobacco on the basis indicated in (a) above. Such supply is to be drawn in the naval establishment from which the officer or rating is discharged.
- (iii) In naval establishments where canteens are conducted by the Australian Army Canteens Service, or where supplies of cigarettes and tobacco are drawn from that source, personnel discharged who desire tobacco supplies are to be furnished with a written authority addressed to the canteen manager and signed by a responsible officer, indicating the date of discharge and authorizing an issue of the approved quantity of cigarettes and tobacco for a period of 24 days from date of discharge.

(612/244/114.)

(This Order will be reprinted for posting on Notice Boards.)

RESTRICTED.(FOR OFFICIAL USE ONLY.)

Commonwealth Navy Orders.

Navy Office, Melbourne,

6th March, 1945.

The following Orders, having been approved, are hereby promulgated for information and guidance and necessary action.

By direction of the Naval Board,

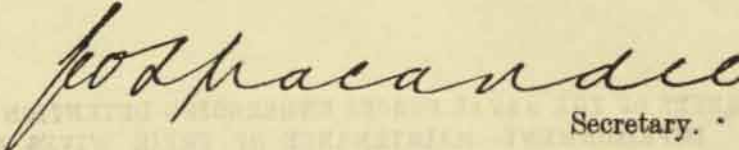
Secretary.

*The Commodore Commanding H.M.A. Squadron,
and Commanding Officers of H.M.A. Ships,
Officers in Charge of H.M.A. Naval
Establishments, and others concerned.*

TABLE OF CONTENTS.

No.	Subject.
83.	H.M.A.S. "Carpentaria"—Commissioning.
84.	R.A.N. Armament Depot, Fremantle—Title of Officer-in-Charge.
85.	Members of the Naval Forces Undergoing Detention or Imprisonment—Maintenance of their Wives and Children.
86.	Boxes Ammunition C.222.
87.	Penicillin—Casualty Label Army Form A.A.F. D113.
88.	Vaccination.
89.	Special Clothing Issues for Personnel in Forward Island Areas.
90.	Disposal of Garbage and Ashes from H.M.A. Ships at Outer Harbour and Port Adelaide.

83.

H.M.A.S. "CARPENTARIA"—COMMISSIONING.

The Naval Establishment on Thursday Island was commissioned as H.M.A.S. *Carpentaria* on 16th February, 1945.

(1867/2/122.)

84.

R.A.N. ARMAMENT DEPOT, FREMANTLE—TITLE OF OFFICER-IN-CHARGE.

The title of the Officer-in-Charge of the Naval Armament Depot, Fremantle, will in future be Naval Armament Supply Officer, Fremantle (short title, N.A.S.O.).

(404/201/699.)

85.

MEMBERS OF THE NAVAL FORCES UNDERGOING DETENTION OR IMPRISONMENT—MAINTENANCE OF THEIR WIVES AND CHILDREN.

In cases where married members of the Naval Forces are detained awaiting trial and subsequently sentenced to imprisonment or detention with consequent cessation of pay, allotments are to be declared at or reduced to the standard rate plus marriage allowance from the pay period following the date of commencement of the waiting trial period. In all such cases marriage and child allowance (if any) are to be credited and the full amount of the allotment is to be charged. When such a member is to be retained in the Service on completion of his period of detention or imprisonment, the debit balance so accrued is to be recovered in suitable instalments upon his return to duty.

2. In cases where such members are subsequently approved to be discharged on completion of sentences, the question arises of liability for the maintenance of their wives and children in the interim.

3. It has been decided that where a member's sentence of detention or imprisonment is imposed for a Service offence, e.g., desertion, the Naval Department will accept, to a degree, liability for the maintenance of the member's legal wife and children if they are in indigent circumstances. Where, however, imprisonment or detention is imposed for a civil offence, the maintenance of such dependants will remain the liability of the State in which they are residing, assistance being rendered in both cases at the State rate in force. The term "legal wife and children" means his legal wife and any children for whom child allowance was being paid prior to the member's discharge on the basis that they were members of his household.

4. When approval for subsequent discharge of a member is given in such cases, action will be taken from Navy Office to advise the member's wife of the occurrence, and of the date upon which payment of her allotment will cease. Such allottee will also be informed that, if her financial position warrants it, immediate application should be made by her to the State Welfare Department in the State in which she resides (the address being stated) and that her case will be examined by them as to her eligibility for assistance. Necessary particulars will also be forwarded to the State Department from Navy Office, i.e., member's name, place of imprisonment, period of sentence, and copy of advice to wife, and later, date of member's discharge, where possible, in advance. The date of discharge should be communicated to the Director of Navy Accounts at least fourteen days prior to such date.

5. To allow of a period for the investigation of each case by the welfare authorities and to obviate distress, payment will be continued from Navy Office in respect of the wife for two pay days from date of such notification to the wife, at the standard rate of allotment plus marriage allowance.

6. The actual date of stoppage of allotment and marriage allowance of such cases will be communicated by the Director of Navy Accounts to H.M.A. ship carrying the account of the member.

7. The State Welfare Departments and addresses are—

Victoria—

Children's Welfare Department (Secretary),
Railway Building,
Flinders-street,
Melbourne, C.1.

New South Wales—

Child Welfare Department (Director),
Bridge-street,
Sydney, New South Wales.

Queensland—

State Children's Department (Director),
William-street,
Brisbane, Queensland.

Western Australia—

Child Welfare Department (Secretary),
508 Hay-street,
Perth, Western Australia.

South Australia—

Children's Welfare and Public Relief Department (Secretary),
Paddock Chambers,
Victoria-place,
Adelaide, South Australia.

Tasmania—

Social Services Department (Director),
4 Macquarie-street,
Hobart, Tasmania.

8. The above procedure will apply only to cases of detention or imprisonment which occur subsequent to 9th March, 1945.

(556/207/4666.)

(This Order will be reprinted for posting on Notice Boards.)

86.

BOXES AMMUNITION C.222.

As it has now been established that stacking of boxes ammunition C.222 upside down does not prevent ingress of water, Navy Order 416 of 1944 is hereby cancelled.

(421/202/799.)

87.

PENICILLIN—CASUALTY LABEL ARMY FORM A.A.F. D113.

A casualty "Tie on" label—Army No. A.A.F. D113—is being adopted in the R.A.N. for casualties requiring continuation of Penicillin treatment.

2. The labels are to be attached at the time of the first injection and details of the initial and all subsequent injections are to be recorded in the appropriate columns on the reverse side of the card.

3. As soon as stocks are available the Medical and Dental Store Officer will effect distribution without demand to all H.M.A. ships and establishments carrying a medical officer.

4. Upon completion of treatment, the label is to be firmly affixed to the patient's medical history documents.

5. The scale will be—

Cruisers	10 each.
Hospitals	50 each.
L.S.P's.	20 each.
Destroyers	5 each.
Sloops	5 each.
Other vessels carrying a medical officer				5 each.

6. Scale of Medical Stores—Printed Forms section—should be amended accordingly.

(527/211/2105.)

88.

VACCINATION.

The attention of all medical officers is drawn to Admiralty Fleet Order 6272/44, particularly to paragraphs 17 and 18.

2. The relative provisions of this A.F.O. will apply throughout the R.A.N.

(527/211/2134.)

89.

SPECIAL CLOTHING ISSUES FOR PERSONNEL IN FORWARD ISLAND AREAS.

In addition to the issues of clothing set out in Navy Order 623 of 1943, Army hats are authorized for personal loan issue under the following conditions, viz. :—

(i) At advanced shore bases under construction between the latitudes of 10° South and 10° North to personnel whose duties are such that Service caps do not provide adequate head cover.

(ii) At established bases within the area specified in (i) above, at the commanding officer's discretion, to personnel whose duties necessitate additional head cover.

2. Requirements are to be obtained from local Army stores, when available, or Royal Edward Victualling Yard, Sydney.

3. The official price of these hats is 13s. 1d. each and this asterisk item is to be added to the current Official Clothing Price List dated 1st May, 1944.

(494/203/565.)

90.

DISPOSAL OF GARBAGE AND ASHES FROM H.M.A. SHIPS AT OUTER HARBOUR AND PORT ADELAIDE.

It is notified for information of H.M.A. ships that the contract with Mr. J. H. B. Bryant, of 25 Third-avenue, Alberton East, South Australia, for the removal of garbage and ashes from H.M.A. ships at Port Adelaide and Outer Harbour to the Municipal Destructor, Adelaide, has been extended to cover the period ending 30th June, 1945.

2. The contract rates operative are as follows :—

(a) Outer Harbour—22s. 6d. per trip.

(b) Port Adelaide—10s. 6d. per trip.

(c) Outer Harbour and Port Adelaide when vessels are lying at both places—22s. 6d. per trip.

3. The contractor is obliged to remove up to 2 tons per trip, should such quantity be available. The prices quoted do not include destructor fees.

4. Payment of the contractor's claims will be effected by the Naval Officer-in-Charge, Port Adelaide. The cartage warrant (Form A.S. 559Y) issued to the contractor to cover removal should be made payable to that officer and should indicate the date and time of service in respect of each ship for information in checking claims. Prior to the departure of H.M.A. ships from the port, the Naval Officer-in-Charge should be advised of the numbers of warrants issued and furnished with a certificate of satisfactory performance of the contract.

5. Navy Order 313 of 1943 is hereby cancelled.

(612/237/160.)

RESTRICTED.(FOR OFFICIAL USE ONLY.)

Commonwealth Navy Orders.

Navy Office, Melbourne,
13th March, 1945.

The following Orders, having been approved, are hereby promulgated for information and guidance, and necessary action.

By direction of the Naval Board,

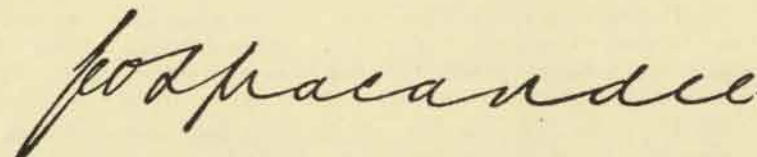

Secretary.

*The Commodore Commanding H.M.A. Squadron,
and Commanding Officers of H.M.A. Ships,
Officers in Charge of H.M.A. Naval
Establishments, and others concerned.*

TABLE OF CONTENTS.

No.	Subject.
91.	Flying of the Duke of Gloucester's Standard and of the Governor-General's Flag.
92.	Additional Officers Borne for Training in H.M.A. Ships.
93.	A.M.S. Vessels—Allocation of Engineer Officer's Cabin.
94.	8-inch Pusher Hoists—Axis Pin of Tumbler Lever Operating Pawl Housing Gear.
95.	A.M.S. Vessels—Main Circulating Water Inlet Pipes.
96.	Cartridges, Signal, 1-inch White Mk. IX.T of M.E. Filling—Lots 8-16 Inclusive—Withdrawal.
97.	Helmets, Steel (R.A.C.) Mark I—Introduction.
98.	Salvus Self-contained Breathing Apparatus, Pattern 3485.
99.	Naval Storekeeping Arrangements and Accounts—Responsibility for Inspection.

91.

FLYING OF THE DUKE OF GLOUCESTER'S STANDARD AND OF THE GOVERNOR-GENERAL'S FLAG.

The Official Secretary to His Royal Highness the Governor-General has advised that the following are the arrangements regarding the flying of the Duke of Gloucester's Standard and of the Governor-General's flag:—

1. His Royal Highness the Governor-General will fly his Personal Standard at Government House, Canberra, and at Admiralty House, Sydney, when in residence.

2. When His Royal Highness goes afloat in a barge or when he embarks in one of His Majesty's or His Majesty's Australian Ships the Governor-General's flag will be flown.

3. When His Royal Highness is inspecting Naval, Military or Air Establishments ashore the Governor-General's flag should be flown.

4. His Royal Highness will fly the Governor-General's flag on his car and aeroplane (the latter when taxi-ing only).

5. During long and fast journeys by car (when flags tear easily) the Governor-General's flag will be replaced by an oblong steel plate with a Governor-General's flag enamelled on it. This will be positioned above the front bumper bar in the centre of the radiator.

6. On motor cars, the flag will be flown from the roof with an enamelled Royal Crown just in front of the flag. The flag will only be flown on the motor car during the day and at night the Crown on the roof will be lit.

7. Description of the flags to be flown are as follows:—

(a) *Personal Standard*.—This is the same as the Royal Standard, but it has the Duke's label on it. The label of His Royal Highness is "of three points argent—the first and third charged with a St. George's Cross, and the centre point with a lion passant guardant gu.". This label appears as a white bar running along the length of the flag at the top.

(b) *Governor-General's Flag*.—The flag consists of "a Royal blue ground on which is the Royal Crest in gold with the words 'Commonwealth of Australia' in blue letters on a gold scroll below the Crest."

With reference to paragraph 1—having in mind the desirability of extending the "life" of flags which are difficult to replace under war conditions, His Royal Highness will have his Personal Standard lowered at sunset and hoisted at 8 a.m.

(476/201/779.)

92.

ADDITIONAL OFFICERS BORNE FOR TRAINING IN H.M.A. SHIPS.

The Naval Board have decided that all candidates promoted from the Officers' Training School are to be appointed to sea as "additional" officers for a period of at least six months prior to allocation to A/S, M/L or further General Service appointments.

2. Commanding Officers of H.M.A. Ships to which these officers are allocated are to ensure that the maximum possible training is given and every endeavour made to bring "additional" officers to watchkeeping standard as early as possible.

3. Attention is drawn to Section V of Forms A.S. 206 when rendered upon "additional" officers on completion of probationary period and as otherwise required by regulations. This information will be of particular importance in confirming allocation as in paragraph 1.

(614/201/27.)

93.

A.M.S. VESSELS—ALLOCATION OF ENGINEER OFFICER'S CABIN.

In certain A.M.S. Vessels where no engineer officer is borne and senior engine room artificers are carrying out the duties of engineer officers, the existing engineer officer's cabin may be temporarily allocated to accommodate additional officers borne for training or other services.

2. In any ship where the above conditions exist, it is approved for ship's staff to convert the wardroom store into an office suitable for use as engineer's office as a temporary measure only.

3. When the conversion as in paragraph 2 above has been made in a ship, the directions in Naval Board message 270454, April, 1944, which authorised the use of the engineer officer's cabin as an engineer's office, will cease to apply to that ship.

(603/267/1587.)

94.

8-INCH PUSHER HOISTS—AXIS PIN OF TUMBLER LEVER OPERATING PAWL HOUSING GEAR.

The modification shown in the appended diagrams D.O.T.M. 84748 and 84749, to the axis pin of the tumbler lever operating the pawl housing gear of 8-inch pusher hoists has been fitted in one of H.M.A. Ships and has proved successful in preventing the axis pin working loose. Access to the locking pin in the modified arrangement is much easier than the existing grub screw.

2. The modification may be carried out by ship's staff if desired.

3. The tumbler lever is to be modified by the addition of an oil hole and groove as shown on the appended diagram D.O.T.M. 84750.

(490/202/1051.)

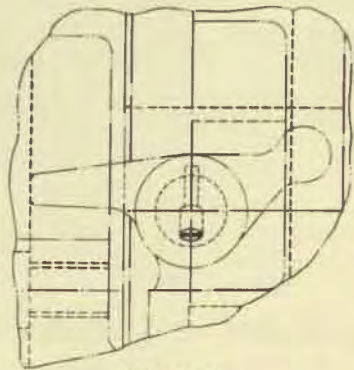

ELEVATION

AXIS PIN TO BE ADJUSTED ON FACES "X" AND "Y" TO LOCATE THE HOLE FOR PIN, LOCKING IN THIS POSITION

.125 DIA. HOLE THEN TO BE DRILLED IN PAWL STOP AND GUIDE BRACKET, USING AXIS PIN AS JIG.

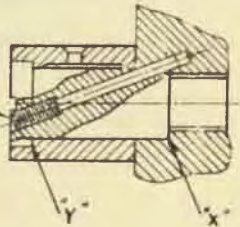

SECTION IN DIRECTION OF ARROW "A"

SEE DIAGRAMS D.O.T.M. 84749 & 84750.

DIMENSIONS ARE IN INCHES.

**8" TWIN MK. I MOUNTING.
SHELL PUSHER HOIST.
OPERATING LEVER ASSEMBLY.**

D.O.T.M. 84748

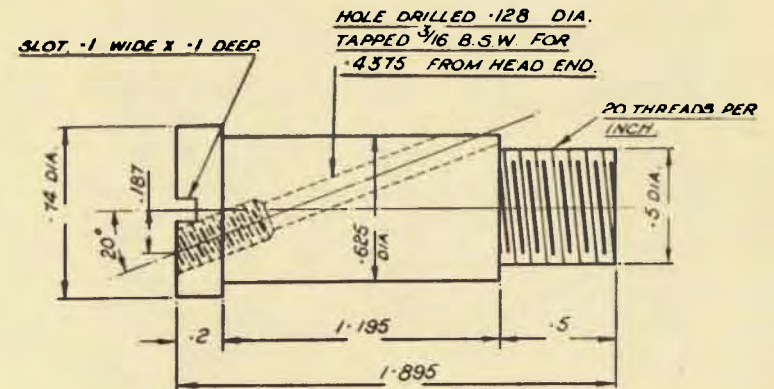

OPERATING PIN AXIS.

MAT'L: - HIGH STRENGTH BRASS.

(F.M.B 3 - M. 66233.)

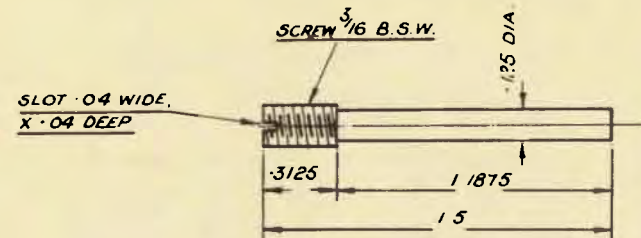

PIN, LOCKING.

MAT'L: - A GRADE STEEL.

DIMENSIONS ARE IN INCHES.

**8" TWIN MK. I MOUNTING.
SHELL PUSHER HOIST.
OPERATING LEVER DETAILS.**

D.O.T.M. 84749.

27245

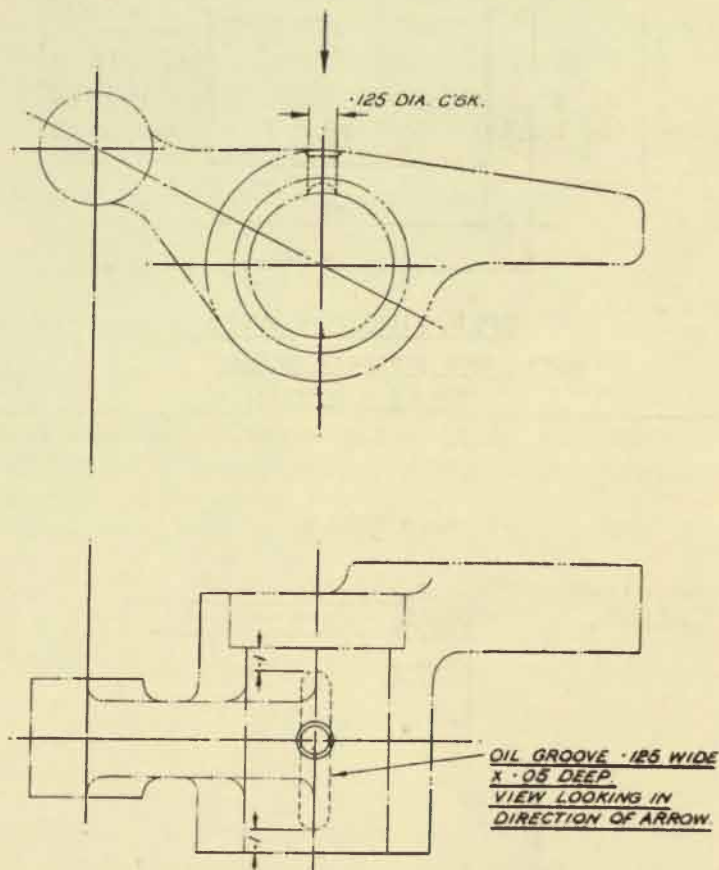

SHOWING POSITION OF OIL HOLE & GROOVE.

DIMENSIONS ARE IN INCHES

**8" TWIN MK. I MOUNTING.
SHELL PUSHER HOIST.
OPERATING LEVER DETAILS.**

D.O.T.M. 84750.

95.

A.M.S. VESSELS—MAIN CIRCULATING WATER INLET PIPES.

The following amendment is to be made to drawing No. 910200 which was reproduced with Navy Order 518 of 1944:—

Bolting of 14½-in. diameter flanges to be "8 in No. ⅝-in. Bolts" in lieu of "6 in No. ⅜-in. Bolts".

(603/267/1535.)

96.

**CARTRIDGES, SIGNAL, 1-INCH WHITE MK. IX.T OF M.E. FILLING
—LOTS 8-16 INCLUSIVE—WITHDRAWAL.**

All cartridges, signal, 1 inch white Mk. IX.T. of M.E. filling, lots 8-16 inclusive in service, are to be withdrawn.

2. All ships are, therefore, to return cartridges, signal, of the above lots to the nearest Naval Armament Depot and to demand a similar quantity of other lots in replacement.

(471/208/1261.)

97.

HELMETS, STEEL (R.A.C.) MARK I—INTRODUCTION.

Supplies of helmets, steel (R.A.C.) Mark I referred to in Admiralty Fleet Order 4969/43 are now to hand for use of officers and upper deck ratings only of Fairmiles and H.D.M.L's. They are to be issued 14 to each Fairmile and 8 to each H.D.M.L. employed in Northern Areas.

2. When the new type helmet is received, the present service pattern steel helmet is to be surrendered and returned to the nearest Naval Armament Depot.

3. Depots are to demand their requirements from the Superintending Armament Supply Officer, Sydney, and ships are to demand from the nearest Naval Armament Depot.

(494/202/225.)

98.

**SALVUS SELF-CONTAINED BREATHING APPARATUS. PATTERN
3485.**

A recent incident, in which the life of a rating in one of H.M.A. Ships was endangered, has drawn attention to the necessity for all concerned in the operation of this apparatus to be thoroughly familiar with its proper use, care, and maintenance.

2. The latest instructions in this regard are contained in B.R. 155A/1943.

3. Ships and establishments which carry this apparatus, but which do not hold this Book of Reference, are to forward demands to the Superintending Naval Store Officer, Sydney, in accordance with Ships' Establishment allowance as shown on page 104 of B.R.I., Book of Reference and I.D. catalogue.

(612/231/371.)

99.

**NAVAL STOREKEEPING ARRANGEMENTS AND ACCOUNTS—
RESPONSIBILITY FOR INSPECTION.**

With reference to Navy Order 444 of 1942, a return of inspections of the Naval Storekeeping arrangements and Naval Store Accounts of H.M.A. Ships attached to a base, or detached tenders visiting a base, carried out by, or on behalf of, the Base Supply Officer in accordance with paragraphs 4 and 5 of the above-mentioned Navy Order, is to be forwarded by the Naval Officer-in-Charge concerned to Navy Office at the end of each quarter. Vessels involved include H.M.A. Frigates, A.M.S. Vessels, Auxiliary M.S. Vessels, and other ships in which Naval Stores and Accounts are not in charge of an Officer of the Supply Branch.

2. The return should cover all inspections made during the quarter and should include the following particulars:—

- (a) Name of ship.
- (b) Date of inspection.
- (c) Matters covered by the inspection.
- (d) Result of inspection.
- (e) Steps taken to correct any irregularities disclosed during the inspection.
- (f) Any general remarks.

3. The first such return rendered is to be for the quarter ending 31st March, 1945.

(612/207/2945.)

By Authority: H. E. DAW, Government Printer, Melbourne.

RESTRICTED.

(FOR OFFICIAL USE ONLY.)

Commonwealth Navy Orders.

Navy Office, Melbourne,

20th March, 1945.

The following Orders, having been approved, are hereby promulgated for information and guidance, and necessary action.

By direction of the Naval Board,

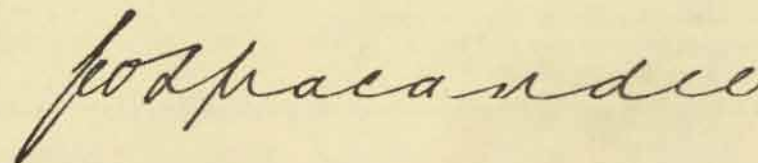

Secretary.

*The Commodore Commanding H.M.A. Squadron,
and Commanding Officers of H.M.A. Ships,
Officers in Charge of H.M.A. Naval
Establishments, and others concerned.*

TABLE OF CONTENTS.

No.	Subject.
100.	H.M.A.S. "Lusair."
101.	H.M.A.S. "Carpentaria"—Commissioning.
102.	Examination for the Rank of Lieutenant-Commander (S).
103.	Examination of Engine Room Ratings—September, 1944.
104.	Convoy Signal Ratings.
105.	Period of Shore Service in New Guinea.
106.	Rifles Aiming 1-in. Elswick "A"—Supply for Use in 4-in., Mark XIX Guns Fitted in H.M.A. Ships.
107.	Victualling Stores—Demands for.
108.	King's Regulations and Admiralty Instructions, 1943.

C.2767/45.

100.

H.M.A.S. "LUSAIR."

The Naval Establishment at Torokina in the Solomon Islands was commissioned as H.M.A.S. *Lusair* on 5th March, 1945.

(1867/2/124.)

101.

H.M.A.S. "CARPENTARIA"—COMMISSIONING.

With reference to Navy Orders 177 of 1943 and 83 of 1945, the motor launch *Silver Lining* has been commissioned as H.M.A.S. *Carpentaria*.

(1867/2/122.)

102.

EXAMINATION FOR THE RANK OF
LIEUTENANT-COMMANDER (S).

An examination for the rank of Lieutenant-Commander (S) will be held towards the end of 1945.

2. Officers who are eligible and desire to sit for this examination should forward their applications to reach Navy Office by the 1st September, 1945.

(565/206/264.)

103.

EXAMINATION OF ENGINE ROOM RATINGS—SEPTEMBER, 1944.

The following results of examinations of Engine Room Ratings is promulgated for information:—

O.N.	Name.	Present Rating.	Application Received From.	Result.
<i>E.R.A. for C.E.R.A. Mechanician I for Chief Mechanician.</i>				
H/1286	Bendall, R. A. ..	E.R.A. 3 ..	<i>Parkes</i> ..	Passed Sat.
24569	Booth, S. L. ..	E.R.A. 3 ..	<i>Nepal</i> ..	Passed Sat.
19699	Brett, A. E. ..	Mechn. 1 ..	<i>Kiama</i> ..	Passed Supr.
F/3271	Caston, J. M. ..	E.R.A. 3 ..	<i>Horsham</i> ..	Passed Sat.
23388	Dummett, G. ..	E.R.A. 3 ..	<i>Nepal</i> ..	Passed.
23301	Fernley, N. J. ..	E.R.A. 3 ..	<i>Hawkesbury</i> ..	Passed Supr.
24262	Haines, N. C. ..	E.R.A. 3 ..	<i>Colac</i> ..	Passed Sat.
F/3270	Harris, S. L. ..	E.R.A. 3 ..	<i>Bendigo</i> ..	Passed Sat.
23967	Kennedy, R. ..	E.R.A. 3 ..	<i>Katoomba</i> ..	Passed Sat.
24414	McGuire, D. ..	E.R.A. 3 ..	<i>Parkes</i> ..	Passed Sat.
W/1259	Matheson, C. A. ..	E.R.A. 3 ..	<i>Shropshire</i> ..	Passed Supr.
5631	Murphy, J. H. ..	E.R.A. 2 ..	<i>B.D.D. Fremantle</i> ..	Passed Sat.
23858	Simpson, R. A. ..	E.R.A. 3 ..	<i>Barcoo</i> ..	Passed Supr.
PM/3451	Snow, R. L. ..	E.R.A. 3 ..	<i>Wagga</i> ..	Passed Sat.
23411	Wylie, W. J. ..	E.R.A. 3 ..	<i>Kiama</i> ..	Passed Sat.

O.N.	Name.	Present Rating.	Application Received From.	Result.
<i>E.R.A., a/4th Class for Confirmation.</i>				
S/5384	Robertson, M. C.	E.R.A., a/4 (M)	<i>Melville</i>	Passed Sat.
<i>Stoker Petty Officer for Chief Stoker.</i>				
6764	Alphred, C. B. ..	S.P.O. ..	<i>Inverell</i> ..	Passed Sat.
20157	Clarkin, T. P. ..	S.P.O. ..	<i>Bendigo</i> ..	Passed Sat.
22283	Dalzell, G. ..	S.P.O. ..	<i>Stuart</i> ..	Passed Sat.
PM/1224	Evans, J. W. ..	S.P.O. ..	<i>Orara</i> ..	Passed Sat.
21969	Hutton, O. J. ..	S.P.O. ..	<i>Stuart</i> ..	Passed Supr.
22172	Langdon, R. W. ...	S.P.O. ..	<i>Warramunga</i> ..	Passed Supr.
21119	Little, F. C. J. ..	S.P.O. ..	<i>Penguin</i> ..	Passed Sat.
21129	McAndrew, S. D. ..	S.P.O. ..	<i>Warramunga</i> ..	Passed Sat.
22306	Moore, J. A. C. ..	S.P.O. (Ty.) ..	<i>Adelaide</i> ..	Passed Supr.
23721	Perry, R. C. F. ..	S.P.O. ..	<i>Warrego</i> ..	Passed Sat.
20886	Skehan, E. A. ..	S.P.O. (Ty.) ..	<i>Adelaide</i> ..	Passed Sat.

2. The necessary notation should be made on Forms A.S. 1233g and A.S. 1246a.

3. Forms A.S. 442 for successful and unsuccessful candidates will be forwarded to ships and establishments concerned for signatures by the candidates. The original is to be retained by the candidate and the duplicate forwarded to the Commodore Superintendent of Training.

4. Candidates who were unable to sit owing to exigencies of the Service may sit for the forthcoming examination without further application being made and passing date will be back dated.

(465/207/1254.)

(This Order will be reprinted for posting on Notice Boards.)

104.

CONVOY SIGNAL RATINGS.

The Convoy Signal section will be manned by the Communications Branch and will comprise ordinary signalman (C), signalman (C), leading signalman (C), and yeoman of signals (C), these terms being used in all official documents referring to them.

2. Ratings for this section will be entered from shore and undergo a special course of twelve weeks' duration at Flinders Naval Depot. On completion they will be drafted for convoy duties.

3. Conditions of advancement are:—

(A) *Ordinary Signalman (C) to Signalman (C)*—

(a) Six months' sea service.

(b) Fifteen months' mobilized service as ordinary signalman (C), less time gained in passing out of Signal School, Flinders Naval Depot.

(c) Recommendation by Commodore of Convoy and advanced by Commanding Officer of ship or establishment where account is borne.

Notes:

- (i) May be rated acting if qualified except by sea time and confirmed on completion of requisite six months' sea time.
- (ii) Time gained up to six months will be assessed by the Naval Officer-in-Charge, Flinders Naval Depot, on completion of Signal School Course.
- (iii) The following is the table of percentages and time which may be gained:—

<i>Percentage.</i>	<i>Time Gained.</i>
97 and over	6 months.
96.5 and over but under 97	5½ months.
96 and over but under 96.5	5 months.
95.5 and over but under 96	4½ months.
95 and over but under 95.5	4 months.
94.5 and over but under 95	3½ months.
94 and over but under 94.5	3 months.
93.5 and over but under 94	2½ months.
93 and over but under 93.5	2 months.
92.5 and over but under 93	1½ months.
92 and over but under 92.5	1 month.
91.5 and over but under 92	½ month.
Under 91.5	Nil.

(B) Signalman (C) to Leading Signalman (C)—

- (a) Passed the course for leading signalman (C).
- (b) Recommendation on Form A.S. 507.
- (c) Six months' sea service as signalman (C).

Notes:

- (i) Recommendations for course for leading signalman (C), *vide* A.F.O. 1483/1944, are to be forwarded to the Naval Officer-in-Charge, Flinders Naval Depot, on Form A.S. 1303A. Selection for the course will be made by the Naval Officer-in-Charge, Flinders Naval Depot, as necessary.
- (ii) May be rated acting if qualified except by sea time and confirmed on completion of requisite six months' sea time.

(C) Leading Signalman (C) to Yeoman of Signals (C)—

- (a) Passed the course for yeoman of signals (C).
- (b) Recommendation of Form A.S. 507.
- (c) Twelve months' service as leading signalman (C), including acting time.

Notes:

- (i) Recommendations for course for yeoman of signals (C), *vide* A.F.O. 1483/1944, are to be forwarded to the Naval Officer-in-Charge, Flinders Naval Depot, on Form A.S. 1303A. Selection for the course will be made by the Naval Officer-in-Charge, Flinders Naval Depot, as necessary.

- (ii) To be advanced to acting yeoman of signals (C) and confirmed after twelve months' service.
- (iii) To be placed on roster according to date of passing the examination for yeoman of signals (C).

4. Except for advancement to signalman (C), advancements will be made by the Naval Officer-in-Charge, Flinders Naval Depot, to fill vacancies in fleet numbers.

5. One yeoman of signals (C) will be allowed in each staff totalling four or more ratings (including higher ratings). Any staff which totals two but less than four will be allowed a leading signalman (C).

6. Serving ratings may volunteer for transfer unless they have already qualified for any active service rating or non-substantive rate.

7. Rates of active and deferred pay will be the same as for ordinary signalman, signalman, leading signalman and yeoman of signals.

8. Convoy signal ratings may, if not employed on convoy duties, be paid the non-substantive allowance applicable to their respective substantive rating, provided they qualify in the usual way.

9. Ratings of the convoy signal section of the Communications Branch, who are qualified for equivalent rating in the general service, may volunteer to revert to general service, subject to manning requirements in the convoy signal section. Transfers to be authorized by the Naval Officer-in-Charge, Flinders Naval Depot, who will withdraw ratings for short course before discharge to general service if necessary.

10. Navy Orders 69 of 1942 and 49 of 1943 are cancelled.

(349/16/376.)

105.

PERIOD OF SHORE SERVICE IN NEW GUINEA.

The provisions of Navy Order 680 of 1944 have been extended to include personnel serving on shore in the New Guinea Area.

(520/201/1250.)

106.

RIFLES AIMING 1-in. ELSWICK "A"—SUPPLY FOR USE IN 4-in. MARK XIX GUNS FITTED IN H.M.A. SHIPS.

Navy Order 614 of 1944 is to be amended by the deletion of paragraph 3 (v).

(412/202/399.)

107.

VICTUALLING STORES—DEMANDS FOR.

It is notified that H.M.A. Naval Victualling Depot, Cairns, has been closed down. The necessary deletion is, therefore, to be made to paragraph 1 of Navy Order 663 of 1944.

(612/248/1482.)

108.

KING'S REGULATIONS AND ADMIRALTY INSTRUCTIONS, 1943.

A new edition of K.R. and A.I. (Volumes 1, 11 and Index—B.R. 31, 32 and 32A) has been distributed by Admiralty without demand to H.M.A. Ships and Naval Establishments.

2. As particulars of distribution by Admiralty are not held by the R.A.N. distributing authority, H.M.A. Ships and Naval Establishments are requested to forward the following particulars to the Superintending Naval Store Officer, Garden Island, Sydney, as early as practicable, in regard to the publication in question:—

(a) Number of copies received.

(b) Number of copies required to complete allowance in accordance with approved R.A.N. Establishment.

3. A.F.O's. 3590, 4320, and 5711/44 refer.

(584/203/137.)

RESTRICTED.(FOR OFFICIAL USE ONLY.)

Commonwealth Navy Orders.

Navy Office, Melbourne,
27th March, 1945.

The following Orders, having been approved, are hereby promulgated for information and guidance, and necessary action.

By direction of the Naval Board,

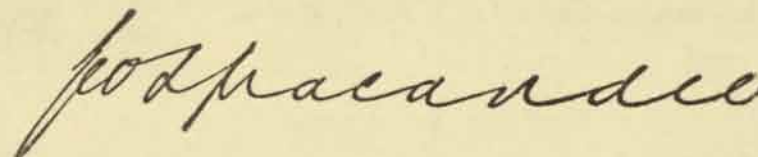

Secretary.

*The Commodore Commanding H.M.A. Squadron,
and Commanding Officers of H.M.A. Ships,
Officers in Charge of H.M.A. Naval
Establishments, and others concerned.*

TABLE OF CONTENTS.

No.	Subject.
109.	H.M.A.S. "Sleuth"—Renaming.
110.	H.M.A.S. "Watson".
111.	Naval Reserve Officers—Qualified Status for Officers of Commander's Rank.
112.	Naval Personnel Delayed in Transit and/or Awaiting Onward Passage by Rail on Completion of Leave.
113.	Maintenance of United States Naval Personnel in Civil Gaols.
114.	Mail from H.M.A. Ships and Naval Establishments.
115.	Commonwealth Reconstruction Training Scheme.
116.	Discharge from the R.A.N. on Account of Physical Unfitness for Service.
117.	Tubes Friction M.R. Signal—Withdrawal of Certain Lots.
118.	Theft and Misappropriation of Stores and Supplies—Precautions.
119.	Meals for R.A.N. Personnel Travelling by Troop Train.
120.	Contracts for Supply of W.R.A.N.S. Ratings' Made-to-Measure Jackets and Skirts.
121.	Contracts for Supply of Ratings' Made-to-Measure Uniforms.
122.	Remittances by R.A.N. Personnel.
123.	A.M.S. Vessels—Arrangements for Cafeteria Service—Modifications to Galley.
124.	Vacancy for Director of Veterinary Services, Bombay, India.

C.2959/45.

109.

H.M.A.S. "SLEUTH"—RENAMING.

H.M.A.S. *Sleuth* has been renamed H.M.A.S. *Hawk*.

(563/201/1419.)

110.

H.M.A.S. "WATSON".

With reference to Navy Order 38 of 1945, H.M.A.S. *Watson* was commissioned on 14th March, 1945.

2. In conformity with Navy Order 177 of 1943, the motor launch 536 has been commissioned as H.M.A.S. *Watson*.

(549/201/137.)

111.

NAVAL RESERVE OFFICERS—QUALIFIED STATUS FOR OFFICERS OF COMMANDER'S RANK.

Approval has been given for the adoption in the Royal Australian Navy for Qualified Status for Australian Naval Reserve officers of commander's rank under the provisions of A.F.O. 4064/1944.

2. Recommendations for the grant of "qualified officer" status for officers concerned are to be forwarded to the Secretary, Naval Board, in due course.

3. Particular attention is drawn to paragraphs 2 and 3 of the above A.F.O.

(428/211/80.)

112.

NAVAL PERSONNEL DELAYED IN TRANSIT AND/OR AWAITING ONWARD PASSAGE BY RAIL ON COMPLETION OF LEAVE.

Information has been received at Navy Office to the effect that many instances are occurring of naval personnel returning to H.M.A. ships and depots, absent over leave, the main reason given being "delayed in rail transit".

2. It would appear that these delays could be attributed to any of the following reasons:—

- (a) Failure on the part of personnel to report to rail transport officers immediately on arrival at R.T.O. Centres, in order to arrange return accommodation.

- (b) Failure on the part of personnel to report back to rail transport officers at such times as directed for the purpose of entrainment.

- (c) Service reasons (e.g., trains running late, thereby missing connexions at capital cities).

3. In order to rectify this matter the following procedure is to be adopted forthwith:—

- (a) All personnel before proceeding on leave are to be instructed to report to R.T.O. centres immediately on arrival at destinations in order to arrange necessary return rail accommodation.

- (b) All instructions issued by rail transport officers regarding rail travel are to be strictly complied with.

- (c) Any neglect by personnel in carrying out instructions, as contained in 3 (a) and 3 (b) above, is to be dealt with as a disciplinary offence.

4. Naval rail transport officers have been instructed to append (by means of a rubber stamp) on leave tickets or home leave passes and rail tickets held by personnel the following information:—

- (i) Time and date personnel report to rail transport officers to arrange return rail accommodation; and

- (ii) time and date personnel have been directed to report for entrainment.

5. Further, Naval rail transport officers have been instructed to forward direct to all commanding officers concerned full details of any delays, either Service or otherwise, occasioned by personnel departing from or passing through their centres.

(632/202/1145.)

113.

MAINTENANCE OF UNITED STATES NAVAL PERSONNEL IN CIVIL GAOLS.

The Department of the Army is responsible for the payment of maintenance of United States prisoners in civil gaols and any accounts received in this regard should be forwarded to that Department for payment.

(401/227/16.)

114.

MATT. FROM H.M.A. SHIPS AND NAVAL ESTABLISHMENTS.

It has come under notice that a considerable quantity of mail is received from H.M.A. ships and naval establishments with either insufficiently prepaid or unpaid postage, resulting in a surcharge by the P.M.G.'s Department of double the amount payable.

2. Wherever possible, stocks of stamps should be maintained and care taken to ensure that all articles posted are fully prepaid.

3. In circumstances in which H.M.A. ships, for operational or other reasons, cannot obtain sufficient supplies of stamps to comply with this Order, postal articles should be clearly endorsed, preferably by means of a rubber stamp, as follows:—

“From H.M.A. Ship—No stamps available.”

(*Note.*—The name of the ship should not appear on the envelope—*vide* Navy Order 23 of 1944, paragraph 48.)

4. In such circumstances, postal regulations provide that the amount of normal postage only will be charged on receipt.

(563/201/1758.)

115.

COMMONWEALTH RECONSTRUCTION TRAINING SCHEME.

In Navy Order 670 of 1944, promulgated at the request of the Industrial Training Division of the Department of Labour and National Service, the attention of all personnel was directed to the need for additional trade instructors to be appointed under the Commonwealth Reconstruction Training Scheme towards or after the cessation of hostilities. The need for instructors in the building trades was stressed.

2. Instructors in art and applied art, science and applied science, mathematical, commercial, needlecraft, and home management courses of various types will also be needed, and it is desired to give members of the Forces who desire to be considered for such appointments the opportunity of lodging applications for selection at a later date.

3. Generally, the services of these instructors will not be required until the cessation of hostilities or just prior thereto.

4. Instructors will be appointed as temporary instructors by the appropriate State Public Service Authority. Conditions of training and employment may be obtained, together with application forms, from the Deputy Director of Industrial Training in the State concerned.

5. Applicants are required to be fully qualified in the branch of technical work for which application is made and preferably to have had some experience as instructors. Selected applicants without satisfactory teaching experience may be required to undergo a short intensive course of training, during which the appropriate rates for instructors will be paid.

6. The addresses of Deputy Directors of Industrial Training are as follow:—

A.C.T.—Canberra Technical College.

New South Wales.—Sydney Technical College, Ultimo, Sydney.

Victoria.—V.C.A. Building, Flinders-street, Melbourne.

Queensland.—Department of Public Instruction, Brisbane.

South Australia.—Education Department, Adelaide.

Western Australia.—Perth Technical College, Perth.

Tasmania.—Education Department, Hobart.

7. It is to be clearly understood that successful applicants will not necessarily be released, since release must at all times be determined by Service requirements.

(840/201/15.)

(*This Order will be reprinted for posting on Notice Boards.*)

116.

DISCHARGE FROM THE R.A.N. ON ACCOUNT OF PHYSICAL UNFITNESS FOR SERVICE.

The conditions relating to the discharge of members of the R.A.N. on account of physical unfitness have been reviewed and are shown hereunder.

2. In regard to date of discharge from the R.A.N.—

(a) A member on full time duty who, following examination by a Medical Board of Survey, is, in the opinion of the Naval Board, unfit for further service will, subject to the provisions of sub-paragraphs (b), (c), (d), (g) and (h) hereof, be discharged from the Service—

(i) When he is no longer, at the time, in need of further active medical treatment as an in-patient and is capable of—

(a) resuming his pre-enlistment occupation; or

(β) following some other occupation; or

(γ) being trained for some skilled occupation; or

(ii) when the period of his treatment in a Service hospital or convalescent depot *in Australia* has totalled six months,

whichever is the earlier.

(b) Where a medical board considers that the member's recovery or rehabilitation into civil life may be furthered by retention in a service hospital or convalescent depot for a further period or periods not exceeding a total extension of six months, recommendation may be made to the Naval Board that the member's discharge be postponed accordingly.

(c) In special cases, such as those with severe amputation, or requiring special bone grafting, facio-maxillary or plastic

surgery treatment, the extension referred to in sub-paragraph (b) may be increased by the Naval Board to twelve months if such extension will further the member's recovery or rehabilitation into civil life.

- (d) A member suffering from an incurable malignant disease whose expectation of life is a matter of months, may, subject to the Naval Board's approval, be retained in a service hospital and his discharge postponed accordingly for as long as he is in need of active medical treatment up to twelve months after the expiration of the period referred to in sub-paragraph (a) (ii) provided that a further extension or extensions may be granted if necessary with the special approval of the Naval Board.
- (e) In cases of pulmonary tuberculosis, whether attributable to war service or not, the time of discharge will be governed by sub-paragraphs (a) and (b) above, and for the purposes of these sub-paragraphs, treatment in a repatriation or other civil institution will be deemed to be treatment in a service hospital or convalescent depot in Australia.
- (f) In cases of incurable or unmanageable mental disease, the provisions of sub-paragraph (e) will apply.
- (g) Subject to sub-paragraphs (d), (e) and (f) above, a member who is unfit for further service as a result of a pre-enlistment disability not aggravated by service or of chronic disease or constitutional inadequacy not related to service, is—
- (i) If no longer in need of immediate active medical treatment and unsuitable for medical rehabilitation, to be discharged with Naval Board approval to the shore as soon as practicable, notwithstanding that the period referred to in sub-paragraph (a) (ii) has not elapsed.
 - (ii) Whilst in need of immediate active medical treatment or suitable for medical rehabilitation, to be retained, with Naval Board approval, until the period referred to in sub-paragraph (a) (ii) has elapsed, and then discharged, notwithstanding the provision of sub-paragraph (b) hereof.
- (h) In amputation cases, a member may be retained in the R.A.N. until an artificial limb has been supplied and he has been instructed in its use, provided that the maximum period of his retention shall not exceed that provided for under sub-paragraph (b) or in cases to which sub-paragraph (c) applies, the period provided for under that sub-paragraph. (See Navy Order 63 of 1942 *re* supply of artificial limbs.)

3. Arrangements are to be made for the attendance of a medical officer of the Repatriation Commission at invaliding surveys and the reason for recommending discharge or further treatment should be clearly stated on Form A.M.252Z. Such surveys should be held at convenient periods, but not less frequently than once a month if cases are awaiting decision.

With reference to C.O.R., Articles 557 (1) and 558 (6), as amended by Navy Order 280 of 1942, prescribing that survey of cases should be held after a period of 151 days' continuous treatment, where a reasonable probability of ultimate fitness for return to duty exists, it will not be necessary for the Repatriation Commission to be represented at such surveys.

4. The opinion of the medical officer of the Repatriation Department, as to the eligibility of the member for war pension, should be noted at the foot of page 4 of Form A.M.252Z.

5. Discharge from the R.A.N. will take place, as a rule, on a date 30 days from the date on which all papers relating to the case are forwarded to the Repatriation Commission from Navy Office. If the case is not one for reference to the Repatriation Commission, discharge will take place 30 days after the date of survey. These periods may be taken as convalescent leave, and the date for discharge will be notified from Navy Office, when approval for discharge is being communicated. In special cases (e.g., where a member is being invalided after a short period of service on account of a pre-existing disability which was not disclosed at medical examination prior to entry) discharge will take place in accordance with Article 200 of Naval Financial Regulations and Instructions—i.e., 14 days beyond date of survey.

Should any change take place in the medical condition of a member during the period of 30 days, necessitating further medical treatment beyond that period, Navy Office approval should be sought for an extension until the member again reaches the stage for discharge as stated in paragraph 1 of this Order.

6. For the information of medical officers, the following are the requirements necessary to establish a diagnosis of pulmonary tuberculosis:—

- (a) The tubercle bacillus to be found on at least two occasions in sputum which has been expectorated in the presence of a medical officer or nursing sister or responsible sick berth rating, or in the gastric contents or pleural fluid; or
- (b) The diagnosis to be agreed upon by a medical representative of the Repatriation Commission, who should be afforded the opportunity of seeing the case, attending the Board or examining the clinical records before the Board is held.

7. Provision of medical treatment and rehabilitation—

- (a) Prior to discharge from the R.A.N., medical treatment and rehabilitation will be provided by the Navy Department, except in the case of patients suffering from pulmonary tuberculosis or incurable or unmanageable mental disease, who should be transferred to a Repatriation or other civil institution, as appropriate, as soon as practicable.
- (b) After discharge from the R.A.N., treatment will be provided as follows:—

(i) Members entitled to Repatriation pensions—

Normally by the Repatriation Commission, except that, in order to meet special circumstances, the provision of treatment may be a matter of arrangement between this Department and the Repatriation Commission.

(ii) Members not entitled to Repatriation pensions—

By civil medical institutions, provided that, pending such accommodation being available, treatment may be continued in a service hospital.

8. Before any member who is an inmate of a service hospital and who does not become a Repatriation responsibility is discharged, arrangements are to be made for the continuation of any necessary treatment in a civil hospital as an in-patient or an out-patient, according to the requirements of the case. The cost of such treatment is not a liability of the Commonwealth beyond date of discharge from the Navy.

9. The following action is to be taken in respect of members surveyed for invaliding:—

(a) Non-Repatriation Cases—

(i) When an unqualified recommendation of discharge "P.U.N.S." or "B.N.P.S." is made by the Medical Board of Survey and where the member concerned no longer needs active medical treatment and can be discharged without detriment to health, approval is given for such member to be discharged to home port and to proceed on convalescent leave until the expiration of 30 days after date of survey whilst awaiting the decision of the Naval Board. (See also paragraph (1) (a) of Navy Order 336 of 1943.)

(ii) When the recommendation of the Board of Survey is qualified, i.e., in cases where a clear recommendation of discharge "P.U.N.S." or "B.N.P.S." is not given, or when any doubt as to ultimate disposal exists, the question of whether discharge is to take place or not will be decided by Navy Office, and a signal made accordingly. Pending receipt of this signal, members coming within this category are not to be sent on leave.

The ship or establishment in which the member is surveyed is to bear the ledger account for the period of travelling and leave involved, making all necessary adjustments, and finally close the account and render Form A.S. 1031Z, &c., to the Director of Navy Accounts. Advice of the disposal of the member concerned is to be forwarded immediately to Navy Office, the Naval Officer-in-Charge, Flinders Naval Depot, and the Naval Officer-in-Charge of the home port.

(b) Repatriation cases—

A member who the Board of Survey (including a Repatriation Medical Officer) considers should be referred to the Repatriation Department, should be sent to home port, if fit to travel, to await Naval Board decision regarding his or her discharge.

10. A member with no disability or whose degree of civil disability is negligible should be sent on convalescent leave as from date of survey, even though he is recommended for reference to Repatriation Department in respect of treatment.

11. To facilitate action in Navy Office, a signal is to be sent after survey for invaliding stating the names and official numbers of members surveyed who have been considered Repatriation cases and who have claims for pension in respect of a degree of civil disability.

12. Navy Orders 93, 440 and 485 of 1943 are hereby cancelled.

(527/211/2117.)

117.

TUBES FRICTION M.R. SIGNAL—WITHDRAWAL OF CERTAIN LOTS.

With reference to Navy Order 634 of 1944 further failures of tubes friction M.R. signal involving blow back and fracture of nib have occurred with tubes of M.F. manufacture filler M.E. lots Nos. 1, 2, 3 and 4 filled 1/38, 2/38, 1/40 and 11/41 respectively.

2. Tubes of these lot numbers are not to be fired and are to be returned to the nearest armament depot and others drawn in lieu.

3. Stocks at naval armament depots, together with those returned, are to be included in a report of survey.

(471/208/1145.)

118.

THEFT AND MISAPPROPRIATION OF STORES AND SUPPLIES—PRECAUTIONS.

The attention of all concerned is drawn to the serious losses in supplies caused by theft and misappropriation.

2. While even isolated instances of theft are serious, the effect on the war effort of persistent stealing is far-reaching.

3. Commanding Officers, Naval Officers-in-Charge, and all concerned are therefore to take all possible precautions to prevent theft or misappropriation of stores and supplies. Such offences are to be viewed seriously and offenders promptly dealt with.

4. Particular attention is again drawn to the necessity for the utmost care in the packing, marking and addressing of stores. Continuous interest must also be taken, as far as practicable, in the movement of consignments from the time of despatch to delivery at destination. Disclosure of contents on packages should be avoided.

(612/254/1384.)

(This Order will be reprinted for posting on Notice Boards.)

119.

MEALS FOR R.A.N. PERSONNEL TRAVELLING BY TROOP TRAIN.

With reference to Navy Order 368 of 1944, the procedure in force provides for issue of Service meal warrants to cover all personnel travelling by troop train.

2. Such personnel may be divided into three categories, viz.:—

- (a) Those travelling on duty;
- (b) those on leave in excess of 48 hours;
- (c) Those on week-end or short leave of 48 hours or less.

3. As indicated in Navy Order 368 of 1944, categories 2 (a) and 2 (b) are provided for by non-credit, during period of troop train travel, of travelling, meal or leave allowances to which normally entitled.

Personnel in category 2 (c) are not entitled to be credited with any such allowances (*vide* Naval Financial Regulations and Instructions, Article 123) and the question of entitlement to supply of meals in such circumstances at Service expense has received consideration. It has been decided that, as regards such personnel victualled normally in a general mess, the cost of meals provided during troop train travel will remain a charge against the Commonwealth.

4. In circumstances, however, in which such a member is in receipt of provision allowance during the period of travel by troop train, the cost of meals supplied is to be recovered by ledger charge against the member's account.

5. Suitable advice for this purpose is to be furnished by the issuing authority to the accountant officer of the ship in which the member's account is borne.

(401/201/3870.)

120.

CONTRACTS FOR SUPPLY OF W.R.A.N.S. RATINGS' MADE-TO-MEASURE JACKETS AND SKIRTS.

The contracts for the supply of W.R.A.N.S. ratings' made-to-measure jackets and skirts which expired on 28th February, 1945—*vide* Navy Order 406 of 1944—have been extended until 30th June, 1945.

2. The names and addresses of the contractors concerned are as follow:—

Melbourne.—Messrs. David Lack, Finlay's Buildings, c/r. Little Lonsdale and Elizabeth streets.

Sydney.—Messrs. David Jones Ltd., Marlborough-street, Surry Hills.

Brisbane.—Messrs. Chas Gilbert and Co., 26-32 Queen-street.

Adelaide.—Messrs. Coultas and Sons, Synagogue-place, off Rundle-street.

Perth.—Messrs. National Clothing Co. (1939) W.A. Ltd., 40 King-street.

Hobart.—Messrs. Garretts Pty. Ltd., 102 Bathurst-street.

3. The prices of the Sydney, Adelaide, Hobart and Brisbane contracts have not been altered.

4. The prices of the Melbourne and Perth contracts have been amended, with effect as from 1st March, and details of the amended prices are as follow:—

	Melbourne Contract.	Perth Contract.
	£ s. d.	£ s. d.
Jacket, double-breasted, diagonal serge with horn buttons ..	2 16 0	3 3 0
Skirt, diagonal serge	1 6 0	1 5 9
Suit	4 2 6	4 8 9

5. Special attention is drawn to the fact that provision is no longer contained in these contracts for purchase of made-to-measure garments to be made on the time-payment principle by means of Service allotments. In future, cash settlement will be necessary on delivery.

(434/216/98.)

(This Order will be reprinted for posting on Notice Boards.)

121.

CONTRACTS FOR SUPPLY OF RATINGS' MADE-TO-MEASURE UNIFORMS.

The contracts for ratings' made-to-measure uniforms which expired on 28th February, 1945—*vide* Navy Order 405 of 1944—have been extended until 30th June, 1945.

2. The names and addresses of the contractors concerned are as follow:—

Melbourne.—Messrs. David Lack, Finlay's Buildings, c/r. Little Lonsdale and Elizabeth streets.

Sydney.—Messrs. David Jones Ltd., Marlborough-street, Surry Hills.

Brisbane.—Messrs. Rothwells Outfitting Ltd., 237-241 Edward-street.

Adelaide.—Messrs. Coultas and Sons, Synagogue-place, off Rundle-street.

Perth.—National Clothing Co. (1939) W.A. Ltd., 40 King-street.

Hobart.—Garretts Pty. Ltd., 102 Bathurst-street.

3. The Adelaide contract does not now provide for the supply of serge jumpers and trousers for Class II. ratings, but an additional contract for the supply of those garments has been arranged with Mr. Claude M. Eatt, 113 Gawler-place, Adelaide, at the following prices:—

Jumpers, Seamen's serge £1 16s. 10d. each
Trousers, Seamen's serge, with fall .. £2 0s. 6d. per pair

4. An additional contract has also been arranged in Brisbane with Messrs. Neville and McKay Pty. Ltd., Essex House, 217 Adelaide-street for the period ending 30th June, 1945. The garments provided for and the prices to be charged are identical with those operating under the contract of Messrs. Rothwells Outfitting Ltd., Brisbane.

5. The prices of the Sydney, Brisbane, Adelaide and Hobart contracts have not been altered.

6. The prices of the Melbourne and Perth contracts have been amended, with effect as from 1st March, and details of the amended prices are as follow:—

	Melbourne Contract.	Perth Contract.
	£ s. d.	£ s. d.
Jacket, double breasted, diagonal serge, with gilt buttons C.P.O.	3 12 6	3 13 6
Jacket, double breasted, diagonal serge, with gilt buttons, P.O.	3 10 6	3 12 0
Jacket, double breasted, diagonal serge, with horn buttons ..	3 7 6	3 10 6
Waistcoat, diagonal serge, with gilt buttons	0 17 3	1 4 0
Waistcoat, diagonal serge, with horn buttons ..	0 15 3	1 3 3
Trousers, diagonal serge, with fly	1 10 0	1 10 9
Jackets, single breasted, seamen's serge, with gilt buttons, C.P.O.	2 17 6	3 4 6
Jackets, single breasted, seamen's serge, with gilt buttons, P.O.	2 17 0	3 3 0
Jackets, single breasted, seamen's serge, with horn buttons ..	2 14 0	3 2 0
Waistcoats, seamen's serge, with gilt buttons	0 17 3	1 3 6
Waistcoats, seamen's serge, with horn buttons ..	0 15 3	1 3 0
Trousers, seamen's serge, with fly	1 7 9	1 10 0
Tunics, drill, with gilt buttons, C.P.O.	1 13 3	1 9 3
Tunics, drill, with gilt buttons P.O.	1 12 3	1 8 0
Tunics, drill, with horn buttons ..	1 10 9	1 7 9
Tunics, drill, without buttons C.P.O.	1 12 0	1 7 3
Tunics, drill, without buttons, other ratings	1 10 3	1 7 3
Trousers, white drill, with fly ..	1 2 6	1 5 0
Jumpers, seamen's serge ..	1 15 0	1 14 6
Trousers, seamen's serge, with fall ..	1 10 0	1 10 6
Jumpers, drill ..	1 8 3	1 9 0
Trousers, drill, with fall ..	1 2 6	1 6 6
Overcoats, blue cloth, with gilt buttons ..	4 6 6	4 19 0
Overcoats, blue cloth, with horn buttons ..	4 5 0	4 17 0

7. Special attention is drawn to the fact that provision is no longer contained in these contracts for purchase of made-to-measure garments to be made on the time-payment principle by means of Service allotments. In future cash settlement will be necessary on delivery.

(434/216/98.)

(This Order will be reprinted for posting on Notice Boards.)

122.

REMITTANCES BY R.A.N. PERSONNEL.

It has come under notice that instances have occurred where remittances have been made in excess of amounts received or due to members, on account of pay and allowances during or for the month, without a report from the Captain of the circumstances under which such remittances were approved.

2. In this connexion, attention is drawn to Naval Account Regulations and Instructions, Article 138, clause 1, the provisions of which are to be strictly enforced in future.

(585/201/1921.)

123.

A.M.S. VESSELS—ARRANGEMENTS FOR CAFETERIA SERVICE—MODIFICATIONS TO GALLEY.

Navy Order 626 of 1944 relates to the introduction of general messing in small ships, and it has been found that the existing facilities in A.M.S. vessels lend themselves to the early introduction of the cafeteria method of food service.

CAFETERIA RACK.

TO BE CONSTRUCTED OF 1/2" S.S.

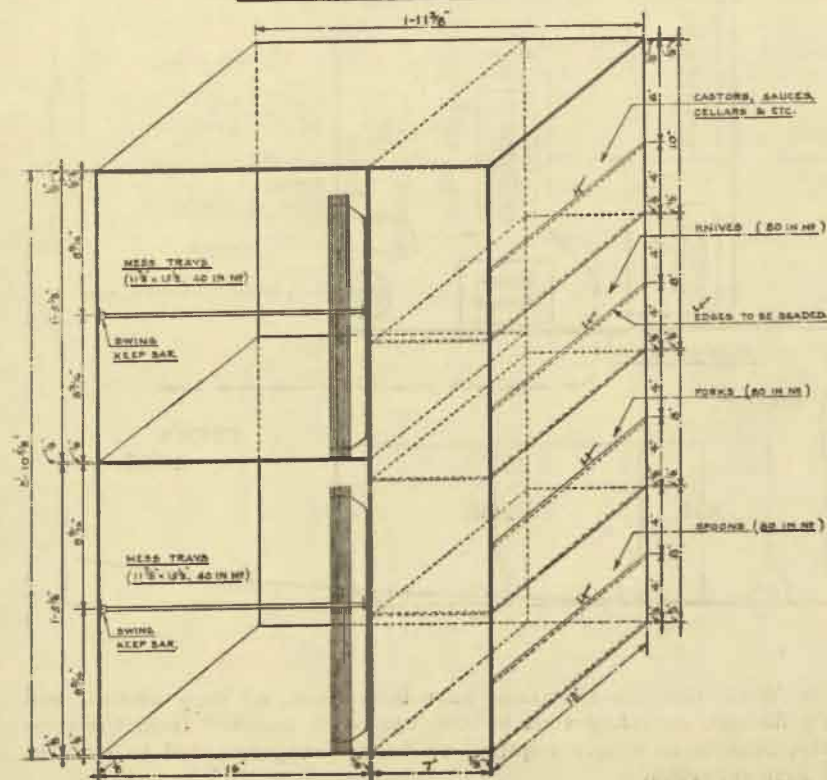

2. To enable that system to operate in A.M.S. vessels, minor modifications are necessary to the present galley arrangements and are to be carried out in accordance with the appended diagrams.

A/S & M/S VESSELS,
ARRGT FOR CAFETERIA SERVICE.

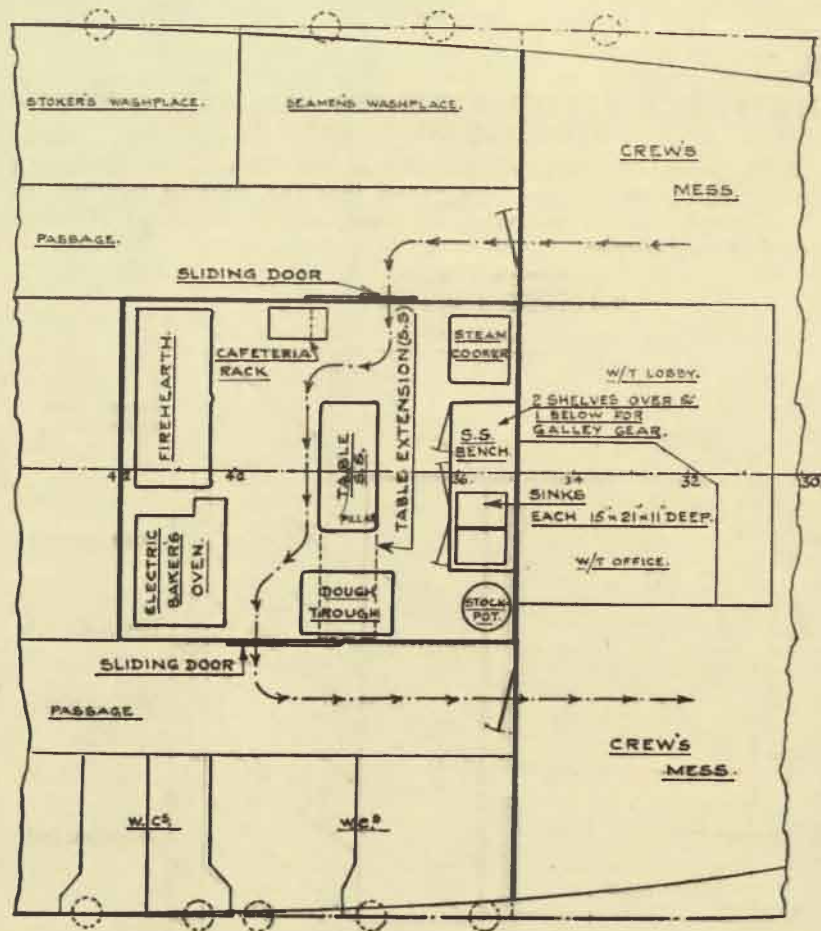

3. When these modifications have been made, all mess utensils and their fittings, including food lockers, are to be removed from the mess decks, articles no longer required on board being returned to store at the first opportunity.

4. The commanding officers of all A.M.S. vessels not already converted are to insert an item in the next main defect list for these modifications to be carried out.

(603/282/1037.)

124.

VACANCY FOR DIRECTOR OF VETERINARY SERVICES, BOMBAY, INDIA.

Applications are invited by the Government of Bombay, India, for appointment as Director of Veterinary Services.

2. The appointment will be on a contract of five years with six months' probation and would be subject to the Bombay Government's obtaining the concurrence of the Secretary of State for India.

3. The salary will be 1,350 rupees per month, rising to 1,750 rupees with annual increments of 100 rupees per month. Overseas pay of £13 6s. 8d. per month will also be payable. (£1 Australian equals approximately 10½ rupees.)

4. An appointee with both veterinary and livestock experience will receive 1,450 rupees per month, rising to 1,850 rupees per month with the same annual increment and overseas pay.

5. The officer's headquarters will be at Poona and he will receive travelling allowance applicable to a first class officer.

6. Applications, stating age and giving full particulars of qualifications and experience, should be addressed to—

K. R. Damle, Esq.,
Official Secretary,
High Commissioner for India,
CANBERRA, A.C.T.

(from whom further information may be obtained if desired) to reach him not later than 30th April, 1945.

(406/201/367.)

(This Order will be reprinted for posting on Notice Boards.)

RESTRICTED.(FOR OFFICIAL USE ONLY.)

Commonwealth Navy Orders.

Navy Office, Melbourne,
3rd April, 1945.

The following Orders, having been approved, are hereby promulgated for information and guidance and necessary action.

By direction of the Naval Board,

John Macandee
Secretary.

*The Commodore Commanding H.M.A. Squadron,
and Commanding Officers of H.M.A. Ships,
Officers in Charge of H.M.A. Naval
Establishments, and others concerned.*

TABLE OF CONTENTS.

No.	Subject.
125.	W.R.A.N.S.—Re-entry of Ratings.
126.	A.M.S. Vessels—Peacock and Smith Evaporating Plants.
127.	Boiler Combustion Cones Manufactured from Heat Resisting Steel.
128.	Maintenance of Refrigerators in H.M.A. Ships and Establishments by the R.A.A.F.
129.	Fitting of Standard Grid Sights to O.Q.F. 40 mm. Bofors—Single Mountings.
130.	Single 40 mm. Bofors Mark IIIA Mountings—Supply of Sights Correctional 40 mm. A.A. Mtgs. Mk. V. (Aust.).
131.	Radar Stores for H.M.A. Ships.
132.	Lifesaving Equipment—Flotanets.
133.	Supply of Provisions to H.M.A. Ships from United States Navy Supply Ships and Depots.
134.	Cordage—Precautions to Prevent Deteriorations.
135.	Flag Lockers.
136.	Protective Clothing.
137.	Women's Royal Australian Naval Service—Uniform and Clothing—Authorized Kit.
138.	Fire Fighting School—Reports.
139.	Books and Forms.

125.

W.R.A.N.S.—RE-ENTRY OF RATINGS.

The following conditions governing the re-entry of ratings into the W.R.A.N.S. have been approved:—

(a) Engagement—

(i) The prior approval of the Naval Board is required in each case before a rating may be re-entered into the W.R.A.N.S.

(ii) An applicant for re-entry is required to produce her former Service Certificate. If she cannot do so, a certified copy shall be forwarded by the Director of Navy Accounts after re-entry has been effected.

(iii) A fresh medical examination and the completion of a fresh form of engagement (R.A.N.R. 6) shall be required.

(iv) Subject to a vacancy existing in establishment numbers, re-entry may be effected in the rating of wran in the category and pay grouping held prior to discharge, otherwise the provisions of N.O.L. 432/224/341 (No. 34420) of 27th April, 1943, shall apply in full.

(v) Any rating higher than wran held during the previous engagement shall be forfeited on re-entry, but the time served may be counted as time in the rating on re-entry.

(b) Advancement—

(i) Provided re-entry is in the same category, former service in the rating may count towards qualifying time for advancement. Seniority is to be adjusted accordingly by the length of time spent out of the Service (*vide* Naval Account Regulations and Instructions, Article 93).

(ii) Ratings recommended for advancement during their former engagement must be recommended again before becoming eligible for advancement on re-entry and, if the conditions of advancement have been made more stringent since they left the Service, care should be exercised that re-entrants satisfy such conditions before being re-advanced.

(c) Good Conduct Badges—

Former service in the W.R.A.N.S. shall automatically count, in accordance with the usual conditions, for the acquisition of good conduct badges. Service in one or more of the other Australian Women's Auxiliary Services may, with the approval of the Naval Board, count in this regard on production of the appropriate documentary evidence.

(d) Uniform—

Ratings on re-entry shall be treated as first entries in respect of issue of kit.

(432/224/2888.)

126.

A.M.S. VESSELS—PEACOCK AND SMITH EVAPORATING PLANTS.

It has been brought to notice that the evaporator coil terminals in a number of the earlier plants manufactured by Messrs. Peacock and Smith for the above vessels, vary in detail from those fitted to the majority of the plants.

2. In the first few plants the diameter of the screwed end of the terminals was 1 inch and the spigot on the securing nuts was $1\frac{3}{8}$ -in. diameter. In the later plants, these dimensions were $1\frac{3}{8}$ inch and $1\frac{1}{2}$ inch respectively.

3. No difficulty will arise until it is necessary to fit new coils of later manufacture, which will have been made to the larger sizes.

4. When these circumstances arise, the alternatives are—

(a) To alter the terminals on the new coils.

(b) To open out the holes on the outside of the steam and exhaust header on the evaporator body.

5. The course to be adopted must be decided by the facilities available at the time, but preference should be given to paragraph 4 (b) if possible, since the larger terminals are fitted to most ships, and base spares are also of this size.

(524/201/2978.)

127.

BOILER COMBUSTION CONES MANUFACTURED FROM HEAT RESISTING STEEL.

There appears to be an excessive demand for replacement of heat resisting cast steel combustion cones in A.M.S. Vessels.

2. Combustion cones of heat resisting cast steel should last indefinitely, and only in rare instances should replacement be necessary, particularly as the supports of heat resisting steel are now fitted to the cone by welding.

3. Attention is therefore drawn to the necessity of conserving these items so far as possible, and to the provisions of Navy Order 91 of 1944 which provides for the return of defective cones to store for reconditioning, in all cases where replacement is found to be necessary.

(603/247/1873.)

128.

MAINTENANCE OF REFRIGERATORS IN H.M.A. SHIPS AND ESTABLISHMENTS BY THE R.A.A.F.

Arrangements have been completed with the R.A.A.F. whereby that Service will undertake, at Australian Ports and Northern Bases, the maintenance and repair of all refrigerator units in H.M.A. Ships and establishments.

2. Defects in refrigerator units are to be brought to the notice of the Naval Officer-in-Charge concerned who will arrange with the local R.A.A.F. representative for the defects to be made good.

3. The R.A.A.F. will only supply such parts as may be necessary to make good defects and will not provide spare parts to complete sets of refrigerator spares normally held by ships and establishments.

4. Replacements of spare parts for refrigerator units are to be demanded on the Central Machinery Spares Depot, Sydney, in accordance with the provisions of Navy Order 666 of 1944.

(524/208/467.)

129.

FITTING OF STANDARD GRID SIGHTS TO O.Q.F. 40 MM. BOFORS—SINGLE MOUNTINGS.

Sets of parts for converting the eyeshooting sights of single 40 mm. Bofors guns to Naval type will become available shortly, and will be supplied without demand for fitting by ship's staff. The sets will be of two types, for sights correctional Mark V and for Sight Bars Mark II. The principal difference is in the size of the bracket, rear sight. On receipt, sights are to be modified in accordance with D.O.T.M. diagram No. 80501 for Sights Correctional Mark V or No. 80502 for Sight Bars Mark II appended to this Order.

2. The grids being supplied are the same in both sets. They are of the same dimensions as an oerlikon grid. The base length is adjusted by the fitting of brackets, rear sight to give the correct aim off and tangent elevation for a range of 1,500 yards. The grids are of a plastic material, and will be supplied in boxes of twelve, one box per mounting, thus affording easy replacement. Further grids will be obtainable on demand from Gunmounting Depots. Spare grids are to be kept in the boxes supplied, until required for fitting.

3. All existing fittings with the exception of those shown in the diagrams are to be removed. Existing holes and securing bolts are to be used unless otherwise indicated on the diagrams.

NOTE.—Existing parts shown chain dotted, new parts in full lines on diagrams.

4. The parts removed are to be returned to the Gunmounting Depot, Garden Island, Sydney, as convenient.

5. Navy Order 548 of 1944 refers.

(490/217/20.)

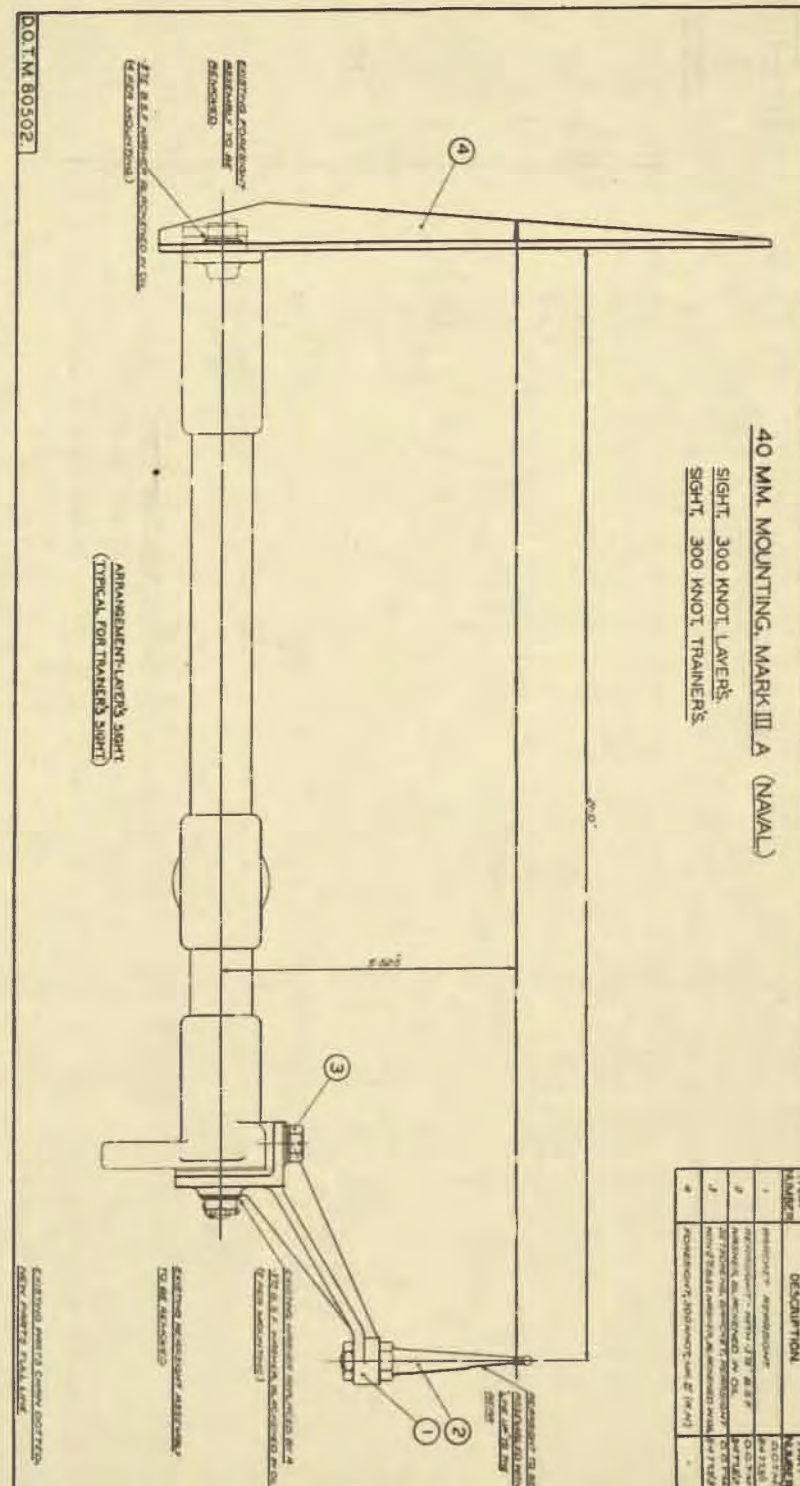

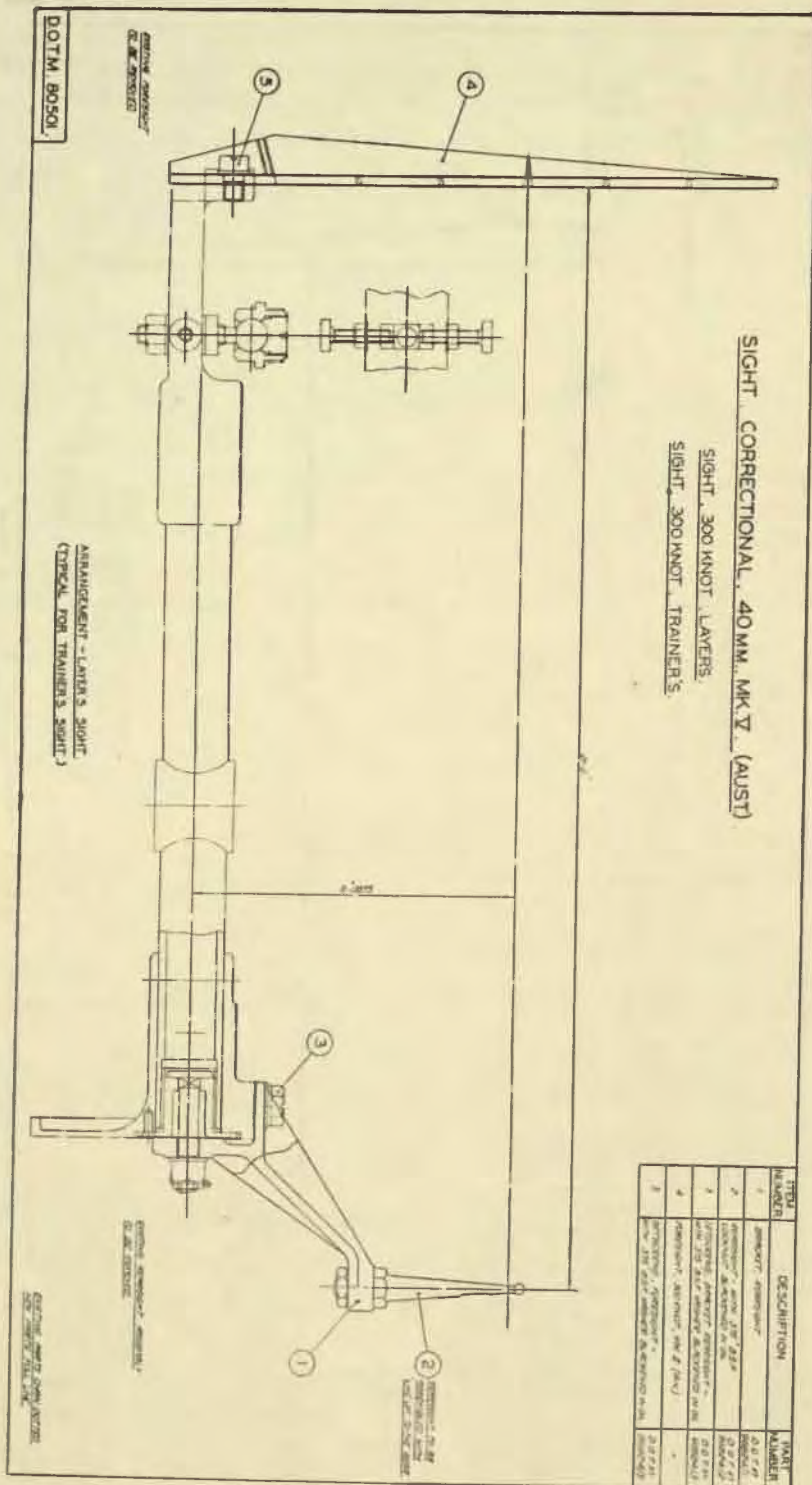

130.

SINGLE 40 MM. BOFORS MARK III_A MOUNTINGS—SUPPLY OF SIGHTS CORRECTONAL 40 MM. A.A. MTGS. MK. V (AUST.).

Paragraph 5 of Navy Order 57 of 1945 is to be amended as follows:—

*For "Tangent Elevation at 2,000 yards at 30 deg.—0.55 feet."
Insert "Tangent Elevation at 2,000 yards at 30 deg.—0.55 minutes."*

(490/217/22.)

131.

RADAR STORES FOR H.M.A. SHIPS.

Instances have occurred recently in which supplies of Radar stores addressed to H.M.A. Ships and despatched to northern bases have failed to reach the addressee, necessitating the raising of further demands for similar items, and resulting in duplication of supply when the first shipment is eventually received on board.

2. Stocks of all Radar equipment are very limited and, to avoid duplication of issues and consequent wastage of equipment, Naval Officers-in-Charge at bases concerned are to take steps to ensure that such equipment is placed on board the vessel to which consigned as early as practicable after receipt at the base, in order that the equipment may be fitted when desired at any convenient port. This procedure is also essential to ensure that ships are fitted with such important equipment at the earliest possible date.

(2037/8/248.)

132.

LIFE-SAVING EQUIPMENT—FLOTANETS.

Experience has shown that the 22 men type flotanets (approximate size 20 ft. x 10 ft.) issued to H.M.A. ships are not entirely satisfactory, mainly for the following reasons:—

- (a) When thrown clear of the ship or when floating clear of a ship, the flotanet tends to roll up and men milling about in the water, especially in a lop, find it very difficult to unroll.

(b) A certain number of men can support themselves on the outer rows of cork, but as soon as weight is placed on the inner area, the flotation again rolls up and tangles men within it.

2. Trials have now proved that the 22 men type flotation can be made much more useful if they are cut into three sections (10 ft. x 6 ft.) each being capable of supporting six persons. The report of certain aspects of the trials of the reduced size net is summarized as follows for general information:—

Test 1.—Six men attempted to board raft from one side. Result: Raft coiled up.

Test 2.—Six men swam to raft; four detailed to hold each corner; two men boarded and were instructed to lie either end face down in prone position; this enabled raft to be kept spread thereby allowing the other four men to board. Result: Satisfactory.

Test 3.—Six men on outside of raft; three men in prone position on back in raft with heads kept well clear of water. Result: Satisfactory for injured men.

Test 4.—Six men on the outside of raft and six men in prone position on raft. Result: Satisfactory providing men on raft kept their *hands* behind head. Raft slightly submerged.

Weather conditions at the time of test—Wind N.E. force 4, sea and swell 23.

3. Further issues of the 22 men type flotation are not to be made and ships' requirements of flotation are to be met by the existing small size, i.e., 9 men type, and/or the modified large net, i.e., 6 men type. Arrangements are to be made forthwith by ship's or base staffs, as appropriate, for modifications to all large size nets held to be effected by reducing to three sections and turning back the ends of the ropes where cut and splicing to the standing part; fitting loops at the corners and tow ropes similar to those fitted on existing flotation (vide Diagram No. 0/1697 appended to this Order).

4. The existing approximate life-saving capacity of flotation allowed to all ships will remain unchanged, and demands for any 6-men type nets found necessary to complete to authorized allowances as a result of modification of the 22-men type net should be forwarded to the nearest Naval Store Depot.

The following is an example of the present and revised allowances of flotation:—

<i>Class of Ship.</i>	<i>Present allowance</i>	<i>Revised allowance.</i>
Frigates.	5-No. 22 men type flotation = 110 men capacity.	19-No. 6 men type flotation = 114 men capacity.

(612/231/325.)

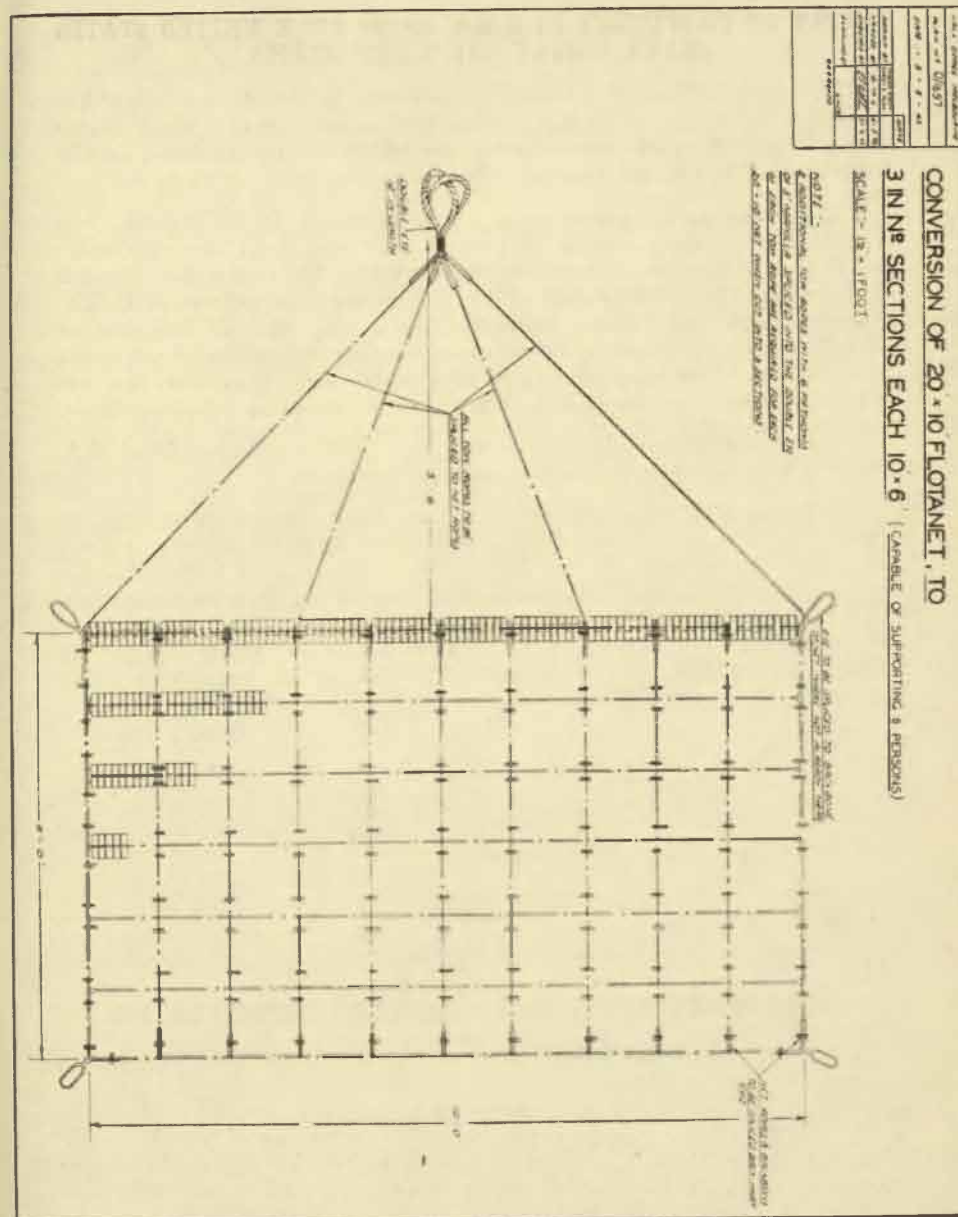

133.

**SUPPLY OF PROVISIONS TO H.M.A. SHIPS FROM UNITED STATES
NAVY SUPPLY SHIPS AND DEPOTS.**

The examination of victualling accounts rendered into office has disclosed that some of H.M.A. Ships have drawn from United States Navy Supply Ships items of provisions which are not included in the current R.A.N. Official Issuing Price List.

2. For the future guidance of all concerned it is notified that the United States Navy system of issuing unit rations is not applicable to H.M.A. Ships, as instructions promulgated by Comserfor Seventh Fleet, under date of 25th July, 1944, to Commanding Officers of U.S.N. Supply Ships and Depots, intimated, *inter alia*, that in the case of R.A.N. vessels the standard procedure of issuing the full balanced ration or unit was to be suspended, and that only such provisions as are actually allowed in the R.A.N. list are to be supplied when available.

3. Demands for provisions required from the above sources by H.M.A. Ships are to be prepared accordingly as necessary.

4. It has also been brought to notice that on occasions supplies of provisions have been obtained by H.M.A. Ships from United States Navy or Army sources and the quantities received have not been taken on charge, and accounted for in the normal manner for issue on repayment, merely because supply and receipt notes were not passed at the time. Such supplies are invariably to be recorded in the store accounts in future on the date of receipt and dealt with in all respects as ship's stores.

(2026/2/1038.)

134.

CORDAGE—PRECAUTIONS TO PREVENT DETERIORATION.

4½-in. manila motor boat falls, which had been fitted for four months, but which had been used infrequently, were being turned end for end in one of H.M.A. Ships, and it was discovered that the in-board end of the cordage had deteriorated through the formation of mould inside the lay of the strands. When this cordage was worked by hand, the yarns parted. A life-line of similar cordage parted when eight men pulled on it to turn out the boat.

2. Experience generally discloses that cordage of the quality now available for supply deteriorates quickly under tropical conditions, e.g., rains followed by intense heat. With a view to arresting this depreciation, boats' falls in ships in northern waters in particular should be turned end for end every six weeks to provide adequate ventilation.

(612/225/674.)

135.

FLAG LOCKERS.

When the U.S. System of signalling is adopted in the R.A.N., flag lockers of H.M.A. Ships, Establishments and Signal Stations should conform to the following diagram. In small vessels, wallets and lockers should be marked to conform as nearly as practicable to the diagram.

U.S. SIGNAL FLAGS.

FLAG LOCKER MARKINGS.

Pt. 1	2	3	4	5	6	7	8	9	Θ
AFIRM	B	C	D	E	F	G	H	INT	J
K	L	M	NEGAT	OPTION	PREP	Q	R	S	T
U	V	W	X	Y	Z	1st RPT	2nd RPT	3rd RPT	4th RPT
CORPEN	TURN	FORM	POSIT	SPEED	DIV.	SECT	SQUAD	FLOT	ANS
Fl: 1	2	3	4	5	6	7	8	9	Θ
	SOPUS	DESIG			EMERG			DEPLOY	CODE
		BLUE FLAG			/SC	BLACK PDT.			

NOTE.—“EMERG” to be marked in RED lettering on white background.

(421/203/83.)

136.

PROTECTIVE CLOTHING.

The special attention of all concerned is drawn to the provisions of Navy Order 231 of 1944 regarding the wearing of protective clothing, as a precautionary measure against malarial infection, on the occasions and in the areas specified therein.

(516/201/633.)

137.

**WOMEN'S ROYAL AUSTRALIAN NAVAL SERVICE—UNIFORM
AND CLOTHING—AUTHORIZED KIT.**

Navy Order 375 of 1943 is to be amended in paragraph 4 (e) on page 5 by the addition of "Q.O. and Q.O. (O) Ratings" after the words "Supply Assistants".

(516/201/724.)

138.

FIRE FIGHTING SCHOOL—REPORTS.

With reference to Navy Order 664 of 1944, copies of reports concerning outbreaks of fires and the action taken in subduing them are to be forwarded in future to:—

(a) Naval Officer-in-Charge, Flinders Naval Depot; and

(b) Commanding Officer, H.M.A.S. *Penguin*,

for the information of the fire fighting and damage control schools.

(475/201/228.)

139.

BOOKS AND FORMS.

First supplies of the under-mentioned publications have been distributed. Further supplies of B.R.'s 915 (1) and 1085 are being obtained to complete distribution:—

B.R.70.—Signal Letters of British Ships—June Supplement.

(A.F.O. 6226/44.)

(571/202/1654.)

B.R.141/44.—R.M. Clothing, Appointments, &c.—Issuing Prices, &c.

(A.F.O. 5489/44.)

(571/202/1840.)

B.R.264/44.—Notes for Instruction in Eyeshooting.

(571/202/2096.)

B.R.268 (37).—Electrical Manual, Volume II, Handbook of Emergency Searchlight Sight.

(A.F.O. 628/44.)

(571/202/2040.)

B.R.293/44.—Handbook for the Apparatus A.D. Type J Mark

II.

(A.F.O. 4419/44.)

(571/202/2047.)

B.R.317 (23), (24), (25), (26) and (27).—Mining Drill Book.
(A.F.O's. 5599 & 6771/44.)
(571/202/1970.)

B.R.640 (27).—Combined Operations, Hardening of Commando Troops for Warfare.

(A.F.O. 3890/44.)

(571/202/1837.)

B.R.642 (B.).—Summary of British Warships.

(A.F.O. 2804/44.)

(571/202/2097.)

B.R.762.—Janes' Fighting Ships—1943-1944 Edition.

(A.F.O. 6226/44.)

(571/202/1826.)

B.R.827.—A Seaman's Pocket Book.

B.R.827A.—Ship Safety.

(A.F.O. 6056/43.)

(571/202/1903.)

B.R.915 (1).—Addendum No. 1 to B.R.915—Handbook for the 5.25" Q.F. Mark I. Gun on the H.A./L.A. Marks I. and II. Mountings for mountings fitted with R.P. 1944 Issue.

(A.F.O. 4176/44.)

(571/202/1895.)

B.R.989 Series.—Index to Supplementary Naval Intelligence Papers (M.P.) C.B.03122 Series.

(571/202/2092.)

B.R.1019 (Restricted).—Manual of Astro Navigation for the Fleet Air Arm.

(A.F.O. 2406/44.)

(571/202/1981.)

B.R.1027.—New Atlas of Japan by Fuzita Motoharu.

(A.F.O. 1620/44.)

(571/202/1959.)

B.R.103 (Restricted).—Book of Blast Curves.

(A.F.O. 4317/44.)

(571/202/2050.)

B.R.1048.—Handbook of Big Curves of Enemy Moored Mines and Obstructors—Plates 10-15 inclusive.

(A.F.O. 6226/44.)

(571/202/2072.)

B.R.1085 (Supersedes O.U.6324).—Regulations for Maintenance of A.B. Marks I. and I.* (including Mods. 1, 2 and 3 Gyroscopes).

(A.F.O. 3772/44.)

(571/202/2034.)

B.R.1098A (1).—Index to Supplementary Naval Intelligence Papers relating to Geographical Matters on the Far Eastern Station, C.B. 03140A (1).

(571/202/2103.)

Army Training Memorandum (War) (Australia) No. 38.

(546/201/443.)

2. The under-mentioned form has been introduced for use in the R.A.N. in lieu of the corresponding Admiralty Form S.308. First supply will be made, without demand, by the Superintending Naval Store Officer, Sydney.

A.S.308.—Report of Torpedoes Fired in Action.

(A.F.O. 236/44.)

(C.A.F.O. 2200/44.)

(480/202/4504.)

3. The under-mentioned forms have been adopted for use in the R.A.N.. First supply will be made, without demand, by the Superintending Naval Store Officer, Sydney.

S.414—Fighter Direction Plot.

(C.A.F.O. 2554/43.)

(480/202/4630.)

S.1701.—Aircraft Recognition Posters. (Set 1-12.)

(480/202/4672.)

RESTRICTED.(FOR OFFICIAL USE ONLY.)

Commonwealth Navy Orders.

Navy Office, Melbourne,
10th April, 1945.

The following Orders, having been approved, are hereby promulgated for information and guidance and necessary action.

By direction of the Naval Board,

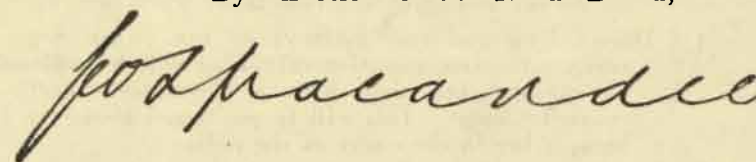

Secretary.

*The [Commodore Commanding H.M.A. Squadron,
and Commanding Officers of H.M.A. Ships,
Officers in Charge of H.M.A. Naval
Establishments, and others concerned.*

TABLE OF CONTENTS.

No.	Subject.
140.	Flying of the Duke of Gloucester's Standard and of the Governor-General's Flag.
141.	Naval Reserve Officers—Grant of Acting Rank or Relative Rank of Lieutenant-Commander.
142.	Fuzes—Time Mechanical—Maintenance of Pre-set Fuzes.
143.	Radar Stores—Supply, Custody and Accounting.
144.	Return of Loan Items of Uniforms and Clothing and Anti-gas Respirators on Final Discharge.
145.	Ships' Library Books—Purchase Price Limit.

140.

FLYING OF THE DUKE OF GLOUCESTER'S STANDARD AND OF THE GOVERNOR-GENERAL'S FLAG.

The Official Secretary to His Royal Highness the Governor-General has advised that the following are the arrangements regarding the flying of the Duke of Gloucester's Standard and of the Governor-General's Flag:—

- (a) His Royal Highness the Governor-General will fly his Personal Standard at Government House, Canberra, at Admiralty House, Sydney, and at any other Government House where His Royal Highness may be in residence.
- (b) When His Royal Highness goes afloat in a barge or when he embarks in one of His Majesty's or His Majesty's Australian Ships, the Governor-General's Flag will be flown.
- (c) When His Royal Highness is inspecting Naval, Military or Air Establishments ashore, the Governor-General's Flag should be flown.
- (d) His Royal Highness will fly the Governor-General's Flag on his car and aeroplane (the latter when taxi-ing only).
- (e) During long and fast journeys by car (when flags tear easily), the Governor-General's Flag will be replaced by an oblong steel plate with a Governor-General's flag enamelled on it. This will be positioned above the front bumper bar in the centre of the radiator.
- (f) On motor cars, the flag will be flown from the roof with an enamelled Royal Crown just in front of the flag. The flag will only be flown on the motor car during the day and at night the Crown on the roof will be lit.
- (g) Description of the flags to be flown are as follows:—

(i) Personal Standard.

This is the same as the Royal Standard, but it has the Duke's label on it. His Royal Highness's label is "of three points argent—the first and third charged with a St. George's Cross, and the centre point with a lion passant guardant gu". This label appears as a white bar running along the length of the flag at the top.

(ii) Governor-General's Flag.

The flag consists of "a Royal blue ground on which is the Royal Crest in gold with the words 'Commonwealth of Australia' in blue letters on a gold scroll below the Crest".

2. With reference to sub-paragraph (a)—having in mind the desirability of extending the "life" of flags which are difficult to replace under war conditions, His Royal Highness will have his Personal Standard lowered at sunset and hoisted at 8 a.m.

3. Navy Order 91 of 1945 is cancelled.

(476/201/779.)

141.

NAVAL RESERVE OFFICERS—GRANT OF ACTING RANK OR RELATIVE RANK OF LIEUTENANT-COMMANDER.

The provisions of A.F.O. 24/1945 are adopted for the R.A.N. This A.F.O. cancels A.F.O. 3927/1944 and A.F.O. 6528/44.

2. "A.F.O. 24/1945" is to be substituted for "A.F.O. 3927/44" wherever occurring in Navy Orders 607 of 1944, and 2, 39 and 40 of 1945.

3. Attention is directed to paragraph 5 (b) of A.F.O. 24/1945. The recommendation on Form S.206b by reporting officers should conform to this instruction.

4. Particular attention is also drawn to the necessity of reporting upon officers holding the acting rank of Lieutenant-Commander "while holding present appointment" vide paragraph 10 of A.F.O. 24/1945. (428/211/453.)

142.

FUZES—TIME MECHANICAL—MAINTENANCE OF PRE-SET FUZES.

Experience has shown that Fuzes Time No. 211 when set for lengthy periods in temperatures of over 95°F., cannot be re-set or set to safe with service key or fuze setter.

2. To overcome this "setting up", periodical setting of these fuzes, when stowed in ready use lockers and subjected to high temperatures, should be carried out but care is to be taken to ensure that its frequency does not impair the tensioning of the fuze.

3. Ships are to report, after experience has been gained, the interval between routine re-setting operations considered necessary to ensure efficient functioning of the fuzes without adversely affecting the tensioning.

(471/209/1405.)

143.

RADAR STORES—SUPPLY, CUSTODY AND ACCOUNTING.

The following instructions, previously promulgated in a Navy Office circular memorandum, relative to the supply, custody and accounting for radar stores are promulgated for the information and guidance of all concerned.

2. Attention is drawn to the provisions of A.F.O. 1096/43 which require that radio sets and component parts including radar equipment, vide A.F.O. 2403/43, supplied to Yards and Bases for stock and issue, are to be dealt with as ordinary naval stores and held in the custody of naval store officers, or base supply officers, as appropriate. The provisions of this Order are applicable in the R.A.N., but there is no objection to small quantities of radar stores, essential for use during tests, and which are not included in the spares carried in ships, being held in the custody of the port radar officer on behalf of the store officer where this is considered necessary. Particulars of minimum quantities of such items required to be held should be reported to Navy Office. These minimum quantities are to be accounted for as follows:—

(a) *Bases at which a Naval Store Officer is established.*

A receipt for the stores held on loan should be furnished on Yard Issue Note (form D.184) by the radar officer to the naval store officer.

- (i) When issues are made, a receipt, in duplicate, is to be obtained on form A.S.134D by the radar officer from the ship concerned. The quadruplicate copy of the form A.S.134D should be handed to the ship's representative as an "advance" supply note, vide also B.R.4 Art. 12 (2). The remaining copies should be handed to the naval store officer and an equivalent quantity of stores obtained in lieu.
- (ii) When, for any reason, a similar quantity cannot immediately be obtained, a Yard Return Note (form D.83) should be raised to adjust the total quantity on loan from the naval store officer. Similarly, if the quantities on loan are increased, an additional Yard Issue Note should be furnished by the radar officer to the naval store officer.

(b) *Other Bases.*

The stores should be issued into the custody of the radar officer of the base, who should furnish a receipt on forms A.S.156 to the base supply officer. The procedure outlined in paragraph 2 (a) (i) above should be followed in respect of all issues made by the radar officer.

When for any reason a similar quantity of items to that for which receipted demands A.S.134D have been obtained cannot immediately be supplied, a Return Note Form A.S.1091 should be furnished by the radar officer to adjust the quantity of spares in his custody. Similarly, if the initial quantities are increased a receipt on form A.S.156 for the additional items should be furnished by the radar officer to the base supply officer.

NOTE.—It should be observed that issues of radar stores are normally to be made from stocks carried in the base naval store in accordance with usual procedure, except that the radar officer should authorize the ship's demands.

3. Full particulars of radar stores for various types of equipment are shown in the respective "E" Lists or Establishment Lists. These lists, which will be supplied by the Superintending Naval Store Officer, Sydney, vide Navy Order 311 of 1944, set out the items required:—

- (a) for first fitting, i.e., components;
- (b) as spares and accessories to be carried in ships;
- (c) as spares to be carried at bases.

In regard to (a), the set or outfit, e.g., power supply, aerial, &c., comprising the components detailed in the "E" List, or Establishment List, is regarded for accounting purposes as a complete unit, and should be taken on charge as such in ship's naval store accounts—one ledger page being used for each set. The ledger page should be headed as follows, and show in the voucher column a reference to the registered number of the supply note:—

"Radar Set (or Outfit), Type Complete, as per Components shown in Establishment List No."

4. Components comprising a set, &c., are shown in detail on the supply vouchers. In the case of first supply of a complete set, &c., such vouchers should be compared with the "E" List, or Establishment List, and bundled as supporting vouchers to the entry of the complete set as described above, the components of the set, &c., not being taken on separate ledger charge. The complete set should be issued on permanent loan, being described on the appropriate permanent loan list as "Radar Set (or Outfit) Type complete, as per Components shown in Establishment List No.," a copy of the establishment list being maintained for reference purposes. Where subsequent supplies are made to replace components, the individual items should be taken on ledger charge separately in the usual manner. When issued in replacement of a component incorporated in a complete set, they should be written off charge outright in the ledger in a similar manner to items to replace defective fixtures.

5. Items referred to at 3 (b) should be dealt with in ships in a similar manner to ordinary naval stores, i.e., a separate ledger page should be raised for each item and, in the case of permanent items included in spares and accessories, these, if issued on permanent loan, should be dealt with on the normal vouchers and each item detailed separately on the permanent loan list.

6. When preparing demands and supply notes for radar stores, it is essential, to enable the ships to observe the proper accounting procedure, that such vouchers should indicate clearly the type of set for which required, and the category under which the items fall, i.e., whether permanent components, consumable components, permanent spares, consumable accessories, &c. In all cases, the voucher should also show whether the items are for first supply or as replenishment.

7. Items not included in "E" Lists, or Establishment Lists, required by base staffs for fitting an installation, and not accountable as ship's stores, should be demanded from the local store officer by the base officer concerned on Form A.D.184 (when demanded from a naval store officer), or on Form A.S.156 (when demanded from a base supply officer). Such vouchers should clearly indicate the authority for the demand, i.e., job number, Service, &c. It is necessary that the base staff should determine requirements of such stores and lodge demands in sufficient time to enable the items to be obtained, by local purchase or normal transport channels, well in advance of the date on which they are required.

8. Items referred to at 3 (c) required to be maintained at bases are generally as follows:—

- (i) R.N. base spares which include equipment for Admiralty type sets and embrace both R.N. and R.A.N. requirements. Particulars in regard to these spares are shown in Confidential Admiralty Fleet Orders, and the procedure to be followed in regard to demands therefor is set out in Confidential Commonwealth Navy Order 282 of 1944.
- (ii) Spares for U.S. Navy Type radar equipment. These items are held at U.S. Navy supply depots and requests for supply, when necessary, should be made to the appropriate U.S. Navy supply depots.
- (iii) Spares for Australian type equipments have been promulgated in Establishment List No. R.L.E.1, and distribution is being effected accordingly as supplies become available.

9. When new sets are required to be fitted in H.M.A. ships, the stores, including the first outfit of ship spares, will be supplied from one distributing centre, viz., Sydney. The sets to be supplied to various ships, and the order of priority for supply, are shown in the R.A.N. Priority List (R.A.P.) which is issued monthly to all Authorities concerned. This R.A.P. list is the only authority for supply of sets for first fitting in H.M.A. ships, and the Superintending Naval Store Officer, Sydney, will take action to supply in accordance therewith without reference to any other authority. Demands for complete sets should not be raised by any ship or establishment as demands for these sets will be raised by the Superintending Naval Store Officer. Supply will be a direct transaction between the Superintending Naval Store Officer, Sydney, and the ship concerned, but the packages containing the equipment will be consigned to the appropriate naval store officer or naval officer-in-charge for the ship concerned. The packages will be dealt with by store officers as "For Custody only," and where it is essential for delivery of a set to be taken by a base radar officer, he should sign for the packages on behalf of the ship. As receipts for the individual items are required to be furnished by the ship's supply officer to the Superintending Naval Store Officer, Sydney, close liaison between the radar officer and the ship's supply officer is necessary, and the latter officer is to satisfy himself that all the items have been correctly received.

10. It is to be particularly noted that supply will be made without demand by the Superintending Naval Store Officer, Sydney, only for sets required to be fitted in accordance with the R.A.P. List, and for the first supply to bases of base spares as shown in the list of base spares. After first fitting of a set, replenishment of spares as necessary should be demanded by ships from the appropriate naval store depot, or base naval store. Naval store officers, or supply officers required to hold base spares, should raise demands as necessary for replenishment of the first supply made without demand by the Superintending Naval Store Officer, Sydney. Until stocks of base spares are built up to the authorized quantities, demands for *current* requirements will also require to be prepared by supply officers concerned.

11. Navy Order 477 of 1943 and Navy Office memorandum No. 22750, dated 6th March, 1944, refer.

(2037/8/189.)

144.

RETURN OF LOAN ITEMS OF UNIFORM AND CLOTHING AND ANTI-GAS RESPIRATORS ON FINAL DISCHARGE.

Before personnel are despatched to home depots for final discharge, all items of uniform, clothing and loan bedding which personnel are required to return, also anti-gas respirators, are to be recovered by the establishment on the mainland from which the personnel are despatched, and taken on charge by that establishment.

2. Details of items recovered are immediately to be transmitted by air mail to the supply officer and the rehabilitation officer of the home depot concerned.

(516/201/720.)

145.

SHIPS' LIBRARY BOOKS—PURCHASE PRICE LIMIT.

The average purchase price limit in respect of ships' library books has been increased from 4s. 9d. to 5s. 6d. The necessary amendment is to be made to Navy Orders 76 of 1936, 196 of 1940, and 80 of 1941.

2. Navy Orders 178 of 1940 and 223 of 1943 are cancelled.

(664/201/625.)

may
RESTRICTED.(FOR OFFICIAL USE ONLY.)

Commonwealth Navy Orders.

Navy Office, Melbourne,

17th April, 1945.

The following Orders, having been approved, are hereby promulgated for information and guidance, and necessary action.

By direction of the Naval Board,

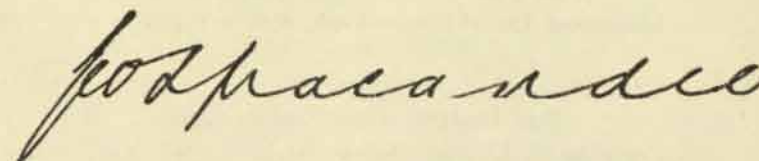

Secretary.

*The Commodore Commanding H.M.A. Squadron,
and Commanding Officers of H.M.A. Ships,
Officers in Charge of H.M.A. Naval
Establishments, and others concerned.*

TABLE OF CONTENTS.

No.	Subject.
146.	Honours and Awards to R.A.N. Personnel.
147.	Educational Test I, December, 1944.
148.	Coding Branch.
149.	Primers, No. 9, Mark I A.N.—Required for Test by I.N.O. Melbourne.
150.	Increased Allowance of Grids for Eye-Shooting Sights for Close Range Weapons.
151.	Instructions for Naval Armament Store Accounting at Certain Shore Establishments.
152.	X-Ray Films—Shortage of.
153.	Influenza Virus Vaccine—Type "A".
154.	Remission of Customs Duties on Goods Sent or Brought to Australia by Naval Personnel.

146.

HONOURS AND AWARDS TO R.A.N. PERSONNEL.

With reference to Navy Order 679 of 1944, the following additional Honours and Awards have been made to personnel of the Royal Australian Navy.

2. *For outstanding survey work under arduous conditions in the Far East.*

O.B.E. (MILITARY).

Commander Karl Oom, R.A.N.

3. *For courage, resolution and skill in H.M.S. Loch Killian in anti-U-Boat operations.*

BAR TO DISTINGUISHED SERVICE CROSS.

Lieutenant-Commander Stanley Darling, D.S.C., R.A.N.V.R.

4. *For courageous leadership and skill whilst serving in light coastal craft in attacks on enemy shipping.*

THE DISTINGUISHED SERVICE CROSS.

Lieutenant Leslie Ernest Yoek, R.A.N.V.R.

5. *For gallantry in the face of the enemy.*

THE DISTINGUISHED SERVICE CROSS.

Engineer Lieutenant-Commander William Monteith,
R.A.N.R. (S).

Lieutenant-Commander George Manley Dixon, R.A.N.V.R.

6. *For gallantry and distinguished service in the work of mine-clearing.*

THE DISTINGUISHED SERVICE CROSS.

Acting Lieutenant-Commander Leon Verdi Goldsworthy,
G.C., G.M., R.A.N.V.R.

7. *For gallantry, determination and devotion to duty in assault on and capture of the Island of Walcheren.*

THE DISTINGUISHED SERVICE CROSS.

Lieutenant Thomas Malins Foggitt, R.A.N.V.R.

8. *For bravery and enterprise in reconnaissance operations.*

THE DISTINGUISHED SERVICE CROSS.

Lieutenant Arthur Reginald Evans, R.A.N.V.R.

Lieutenant (Sp.) Andrew Kirkwall Smith, R.A.N.V.R.

Sub-Lieutenant (Sp.) Kenneth William Tweedale Bridge,
R.A.N.V.R.

MENTIONED IN DESPATCHES.

Lieutenant (Sp.) Thomas Oliver Sexton, R.A.N.V.R.

Sub-Lieutenant (Sp.) Albert Malkin Andreson, R.A.N.V.R.

9. *For distinguished service in successful survey work under dangerous conditions in the Far East.*

THE DISTINGUISHED SERVICE CROSS.

Commander Colin Goyder Little, R.A.N.

Lieutenant-Commander Charles Richard Kelsey Roc, R.N.

Lieutenant-Commander Sydney Ford Bolton, R.A.N.

Lieutenant-Commander D'Arcy Thomas Gale, R.A.N.

Lieutenant-Commander George Dalton Tancred, R.A.N.

Lieutenant Cyril Holt McGee, R.A.N.R.

Lieutenant Harold Murray Knight, R.A.N.V.R.

Lieutenant Cecil Leslie Crook, R.A.N.V.R.

THE DISTINGUISHED SERVICE MEDAL.

Petty Officer Leslie Steward, O.N. 19157.

MENTIONED IN DESPATCHES.

Lieutenant-Commander James Allan Taplin, R.A.N.R. (S).

Lieutenant Ian Wynnum Barns, R.A.N.V.R.

Lieutenant John Joseph Cody, R.A.N.

Lieutenant Bruce Aubrey Reeves, R.A.N.V.R.

Petty Officer James Kilday, O.N. 17924.

Petty Officer Norman Robert Laxton, O.N. 20544.

Able Seaman Raymond Mortimer Casper Archilles, O.N.
B/2977.

Able Seaman Boris Ripley Smith, O.N. PM/2844.

10. *For rescue work in H.M.A. "M.L. 427".*

B.E.M.

Motor Mechanic 4th Class John Archibald Page, O.N. 26046.

MENTIONED IN DESPATCHES.

11. (a) *For good service in Fire Fighting when a Sherman tank caught fire.*

Lieutenant William Fairlie Fergusson, R.A.N.V.R.

- (b) *For gallantry in the face of the enemy.*

Lieutenant-Commander Warwick Seymour Bracegirdle, D.S.C.,
R.A.N.

Lieutenant (E) Charles William Calder, R.A.N.

Lieutenant Eric Kenwyn Sholl, R.A.N.V.R.

Sub-Lieutenant Douglas John Barrington, R.A.N.V.R.

Sub-Lieutenant Ray Forrest Williams, R.A.N.V.R.

Sub-Lieutenant Alaister John McKenzie, R.A.N.V.R.

Chief Petty Officer Telegraphist Eric Clyde Moran, O.N.
19610.

Chief Petty Officer Telegraphist Stanley Greville Smith,
O.N. 17478.

Chief Engine Room Artificer Thomas Wilson Cawood, O.N.
20228.

Mechanician 1st Class Maurice James Hayes, O.N. 19996.

Engine Room Artificer 2nd Class Alexander Kenneth
McDonald, O.N. 23999.

Chief Petty Officer Cook (S) Norman Henry Brown, O.N.
17831.

Petty Officer Donald Alexander Walker, O.N. 19591.
Acting Petty Officer Leslie Raymond Hubber, O.N. 16877.
Leading Stoker James Blyde, O.N. S/3756.

(c) *For outstanding courage, skill and determination in operations in the Mediterranean in light coastal craft.*

Lieutenant Cecil James Cochran, R.A.N.V.R.

(d) *For skill, determination and bravery in anti-U-Boat operations while serving in H.M.S. Terpsichore.*

Lieutenant Frederick Sutton Holt, R.A.N.V.R.

12. *New Year Honours' List, 1945.*

O.B.E. (MILITARY).

Commander (S) (Acting Captain) Patrick Perry, R.A.N.
Reverend William Henry Henderson, Chaplain, R.A.N.

M.B.E. (MILITARY).

Lieutenant-Commander Stanley Hamill Crawford,
R.A.N.R. (S).

Lieutenant Gordon McKinstry Power, R.A.N.V.R.

Mr. William Payne, Commissioned Gunner, R.A.N.

Mr. William Matthew Maughan, A/Warrant Ordnance Officer,
R.A.N.

Chief Yeoman of Signals Francis George Watkins, O.N. 14109.

Chief Stoker Percy Herbert Lynch, O.N. 14323.

Stoker William McCartney Coles, O.N. 18141.

FOREIGN AWARDS AND DECORATIONS.

(Conferred by the President of the United States of America.)

13. *For exceptionally meritorious conduct in the performance of outstanding services to the Government of the United States in action against enemy barge traffic, along the coast of New Guinea and the Western Coast of New Britain during the period from September, 1943, to January, 1944. Participating in numerous patrols aboard Motor Torpedo Boats in enemy controlled waters Lieutenant Howitt piloted a bold and aggressive course by night through a strong hostile screen for the initiation of offensive operations against the enemy. By his marked ability to identify positions and recognize landmarks Lieutenant Howitt contributed essentially to the sinkings or destruction of twenty Japanese barges and two auxiliary ketches and one torpedo boat by patrols under his guidance.*

LEGION OF MERIT (DEGREE OF OFFICER).

Lieutenant Eric Mervyn Howitt, R.A.N.V.R.

14. *For extraordinary fidelity and exceptionally meritorious conduct in the performance of outstanding service.*

LEGION OF MERIT.

(DEGREE OF LEGIONNAIRE.)

Sub-Lieutenant (Sp.) Stanley George Vincent Bell,
R.A.N.V.R.

(448/201/1507.)

(This Order will be reprinted for posting on Notice Boards.)

147.

EDUCATIONAL TEST I, DECEMBER, 1944.

The following ratings passed Educational Test I, held 12th December, 1944.

Name.	Rating.	O.N.	Result.
<i>H.M.A.S. Bowen.—</i>			
Denne, Stanley G. C.	Stoker	H/1746	Passed
Diggles, Percival W.	Stoker	25981 ..	Passed
McAllan, John W.	A/Ldg. Stoker (Ty.)	24840 ..	Passed
Patteson, Gordon D.	Stoker	B/4623	Passed
<i>H.M.A.S. Cerberus.—</i>			
Baulderstone, Percy H.	Stoker, 2nd Class	PA/4777	Passed
Bishop, Leonard ..	Stoker, 2nd Class	F/5415	Passed
Cleaver, Baden C.	Stoker, 3rd Class	H/2757	Passed
Clifford, Bede J. ..	Stoker, 2nd Class	S/9653	Passed
Harris, Ronald A.	Stoker, 2nd Class	W/3013	Passed
Heales, Vincent S.	Stoker, 2nd Class	F/5505	Passed
Heming, Elford H.	Stoker, 2nd Class	PA/4780	Passed
Lamotte, Keith A.	Stoker, 2nd Class	F/5477	Passed
Leverenz, Archibald	Leading S.B.A.	PA/2037	Passed
McConville, John H.	Stoker, 2nd Class	W/3049	Passed
McQuay, Keith	Stoker, 2nd Class	B/5218	Passed
Petersen, Alfred T.	Stoker, 2nd Class	B/5059	Passed
Poulton, John	Stoker, 2nd Class	PA/4871	Passed
Rendell, Noel R. ..	Stoker, 2nd Class	B/5177	Passed
Sharland, Cedric J.	Stoker, 2nd Class	F/5413	Passed
Small, Stanley J.	Stoker, 2nd Class	B/5178	Passed
Thiele, Ronald J.	Stoker, 2nd Class	PA/4841	Passed
Welman, William J.	Stoker, 2nd Class	S/9691	Passed
White, Alfred J. ..	Stoker, 2nd Class	W/3047	Passed
Wightman, George F.	Stoker, 2nd Class	W/3044	Passed
Wilkins, Frank W. J.	Stoker, 2nd Class	W/3057	Passed
<i>H.M.A.S. Gladstone.—</i>			
Clancy, John M. ..	Signalman	24927 ..	Passed
Davies, Newton John	Stoker	F/3791	Passed
<i>H.M.A.S. Katoomba.—</i>			
Cunningham, Keith F.	Ordinary Seaman	B/4725	Passed
Dunk, Desmond A. M.	Able Seaman	24780 ..	Passed
Sadler, Lloyd J. ..	Able Seaman	21201 ..	Passed
Way, Richard T.	Able Seaman	S/8155	Passed
<i>H.M.A.S. Madang.—</i>			
Boal, Walter A. ..	Able Seaman	21955 ..	Passed
<i>H.M.A.S. Melville.—(Including Boom Defence and Tenders)—</i>			
Edwards, William R.	Stoker	H/1790	Passed
Fossilo, Albert D. H.	Stoker	F/3663	Passed
Langlands, Francis J.	Ordinary Seaman	F/5141	Passed
Lowe, Ronald F. ..	Cook (S)	S/7544	Passed
Rowe, Ronald A.	Steward	PM/5462	Passed
Roxburgh, James S.	Writer	H/2686	Passed
Warn, Jack L. ..	Able Seaman	PA/3177	Passed
<i>H.M.A.S. Norman.—</i>			
Vincent, Maurice R.	Stoker	PA/3988	Passed
<i>H.M.A.S. Quiberon.—</i>			
Farlow, Bruce J. T.	Leading Stoker	S/5022	Passed
Fisher, Thomas P.	Able Seaman	F/2803	Passed

Name.	Rating.	O.N.	Result.
<i>H.M.A.S. Shropshire.</i> — Brook, Lindsay S.	Stoker	PA/3304	Passed
The following qualified educationally for Acting Leading Stoker :—			
<i>H.M.A.S. Cerberus.</i> — Baynes, Leslie M.	Stoker, 2nd Class	S/9593	
Birch, Thomas T.	Stoker, 3rd Class	F/5476	
Howard, Albert J.	Stoker, 3rd Class	S/9678	
Hoy, Kenneth E.	Stoker, 2nd Class	S/9679	
Jubb, Garth C.	Stoker, 2nd Class	H/2822	
Leyson, Arthur	Stoker, 2nd Class	S/9590	
O'Connor, James T.	Stoker, 2nd Class	PA/4871	
Stanford, Keith M.	Stoker, 2nd Class	B/5123	
Williams, Harry W.	Stoker, 2nd Class	PA/4872	
Wood, Ernest D.	Stoker, 2nd Class	S/9492	
<i>H.M.A.S. Katoomba.</i> — Berryman, James O.	Able Seaman	PA/2204	
<i>H.M.A.S. Melville.</i> — Sharp, Robert D.	Motor Mechanic	25974	

(465/205/666.)

(This Order will be reprinted for posting on Notice Boards.)

148.

CODING BRANCH.

With reference to Navy Order 339 of 1943, it has been decided that service in shore stations is to be allowed to count as sea service for the purpose of advancement to Petty Officer Coder.

(568/202/998.)

(This Order will be reprinted for posting on Notice Boards.)

149.

PRIMERS, No. 9. MARK I A.N.—REQUIRED FOR TEST BY I.N.O., MELBOURNE.

Fifty primers, No. 9, Mark I A.N., of MF/42 manufacture, from each of Lot 25 filled MY 8/43 and Lot 54 filled MY 11/43, are required for test.

2. These primers may be found in either Q.F. 4-in. Mk. XIX. Q.F. 4-in. V—V* or Q.F. 3-in. 20 cwt. cartridges.

3. Commanding Officers of H.M.A. Ships and Naval Officers-in-Charge are to arrange for loose primers and primers in cartridges to be examined, and, if any of the above lots are found, to report to Navy Office by signal the quantities held.

(408/201/2364.)

150.

INCREASED ALLOWANCE OF GRIDS FOR EYE-SHOOTING SIGHTS FOR CLOSE RANGE WEAPONS.

The necessity for an increase in the allowance of grids for eye-shooting sights for close range weapons has been revealed in recent actions.

2. The allowance of spare grids for eye-shooting sights is therefore to be increased to 100 per cent. in order to allow for both action damage and fair wear.

(490/217/34.)

151.

INSTRUCTIONS FOR NAVAL ARMAMENT STORE ACCOUNTING AT CERTAIN SHORE ESTABLISHMENTS.

Navy Order 20 of 1943 is to be amended as follows:—

Paragraph 14.

Amend first sentence to read:—

“Vouchers for issues and receipts are to be prepared on Form 02, separate vouchers being used for Ordnance and Magazine Stores.”

Paragraph 27.

Delete first sentence and substitute:—

“Original and three copies are to be sent when the consignee is a Naval Armament Depot and original and duplicate copy to other consignees.”

(612/204/1807.)

152.

X-RAY FILMS—SHORTAGE OF.

The supply position in respect of X-ray films is very uncertain.

2. The greatest economy is to be observed by all Ships and Establishments in the use of X-ray films of any description.

(560/203/35.)

153.

INFLUENZA VIRUS VACCINE—TYPE “A”.

All members of the R.A.N., who are attached to shore bases on the mainland of Australia are, as a precautionary measure, to be inoculated with influenza virus vaccine—Type “A”.

2. The dose is one-half cubic centimetre ($\frac{1}{2}$ c.c.) given once only subcutaneously.

3. There is no record of any severe reaction. Should any severe reactions occur following inoculation, the full details are to be reported forthwith to the Director of Naval Medical Services, giving the batch No., etc., of the vaccine.

4. A record is in all cases to be made on the member's medical history sheet thus—“I.V.V./A— $\frac{1}{2}$ c.c. (date)”.

5. The vaccine, when available, will be supplied without demand to all establishments on the mainland.

(527/211/2134.)

154.

REMISSION OF CUSTOMS DUTIES ON GOODS SENT OR BROUGHT TO AUSTRALIA BY NAVAL PERSONNEL.

In accordance with regulation 53 of the National Security (Supplementary) Regulations, customs duties are not chargeable on goods sent or brought to Australia by a member of the Naval Forces serving outside Australia, or a person ordinarily resident in Australia who is serving with the Naval Forces of the United Kingdom, or any gift sent to a member of the Naval Forces serving in Australia.

2. This concession has hitherto been applicable, with respect to any such person, to all goods not for sale or exchange and not exceeding in value ten pounds sterling in any period of twelve months.

3. Regulation 53 has now been amended by excluding from the concession the following goods:—

- (a) Goods being cigars, cigarettes, tobacco or spirituous liquors except in such quantities as the Comptroller-General of Customs considers to be reasonable to meet the immediate needs of the person to whom the goods are addressed or, if brought to Australia by a member of the Naval Forces in accordance with paragraph 1 above, to meet the immediate needs of that person.
- (b) Goods sent by means other than the post unless in special circumstances those other means are approved by the Comptroller-General of Customs.
- (c) Goods sent by any member of the Naval Forces in accordance with paragraph 1 above, the outside container of which does not bear the names of the sender and of his ship or base, unless, in any particular case, the Comptroller-General of Customs directs that it is unnecessary for those names to be borne on the outside container.

4. The quantities of cigars, cigarettes and tobacco which will be granted delivery free of duty in accordance with the provisions of the amended regulation to meet the immediate needs of the person to whom the goods are addressed or, if brought to Australia by a member of the Naval Forces to meet the immediate needs of that person, will be determined in each case in accordance with the attendant circumstances.

5. Commanding officers of ships and establishments outside Australia are requested to bring the revised regulations to the notice of personnel under their command and to take action wherever possible to ensure that they are observed.

(612/250/210.)

(This Order will be reprinted for posting on Notice Boards.)

RESTRICTED.

(FOR OFFICIAL USE ONLY.)

Commonwealth Navy Orders.

Navy Office, Melbourne,

24th April, 1945

The following Orders, having been approved, are hereby promulgated for information and guidance, and necessary action.

By direction of the Naval Board,

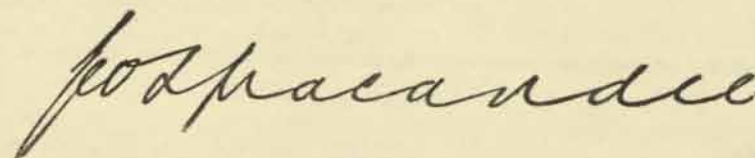

Secretary.

*The Commodore Commanding H.M.A. Squadron,
and Commanding Officers of H.M.A. Ships,
Officers in Charge of H.M.A. Naval
Establishments, and others concerned.*

TABLE OF CONTENTS.

No.	Subject.
155.	Radar Control and Radar Plot Scheme—Policy.
156.	Radio Mechanic Branch—Advancement to Petty Officer Radio Mechanic (S).
157.	Royal Navy Personnel in Australian Service Hospitals.
158.	Personnel Discharged to Hospital in Sydney.
159.	British—U.S. Communication Flags.
160.	Signals—Indications of their Precedence and their Use.
161.	Mercurous Grease—Not to be used with Brasses and Bronzes.
162.	Seasickness Tablets—Issue to Service Afloat.
163.	Repayment Clothing for Tenders.
164.	A.C.F. Club for Women Officers—Sydney.
165.	Motor Vehicles Rear Vision Mirrors.

C.3741/45.

155.

RADAR CONTROL AND RADAR PLOT SCHEME—POLICY.

The following instructions supersede all previous instructions regarding the qualification, advancement and drafting of ratings employed on radar operating duties.

(a) Part I deals with interim substantive and non-substantive rates already established and with the transfer of these rates to the Seaman Branch.

(b) Part II deals with the new and permanent Radar Control and Radar Plot non-substantive ratings.

PART I—INTERIM RADAR CONTROL AND RADAR PLOT RATES.

2. All existing radar ratings at the date of issue of Navy Order 543 of 1944, viz.:—17th October, 1944, have been transferred to one of the following interim categories as from 15th May, 1944, or date of first qualifying if this were after 15th May, 1944.

This table shows only the rates to which ratings were actually transferred, that is, because there were no Petty Officers (Radar) qualified in seamanship, this category is not shown. Thus the table mentions only those categories which will actually be encountered.

TABLE A.

Ratings Fully Qualified in Seamanship and Fully Qualified in Plotting or Fire Control.	Ratings not Qualified in Seamanship but Qualified in Plotting or Fire Control.	Ratings not Qualified in either Seamanship or Plotting or Fire Control.	Ratings Qualified in Seamanship but not in Fire Control or Plotting.
Ldg. Seaman R.P.2	Ldg. Seaman (Radar) R.P.	P.O. (Radar) R.P.(P)	Ldg. Seaman R.P.2(P)
Ldg. Seaman R.C.2	Ldg. Seaman (Radar) R.C.	P.O. (Radar) R.C.(P)	Ldg. Seaman R.C.2(P)
A.B. R.P.3	A.B. (Radar) R.P.	Ldg. Seaman (Radar) R.P.(P)	A.B. R.P.3(P)
A.B. R.C.3	A.B. (Radar) R.C.	Ldg. Seaman (Radar) R.C.(P)	A.B. R.C.3(P)
Ord. Seaman a/R.P.3		A.B. (Radar) R.P.(P)	Ord. Seaman a/R.P.3(P)
Ord. Seaman a/R.C.3		A.B. (Radar) R.C.(P)	Ord. Seaman a/R.C.3(P)

NOTES.

(i) (a) The suffix (P) in columns 3 and 4 indicates a "provisional" non-substantive rate and that, although fully qualified in radar, ratings must qualify in plotting or gunnery before being confirmed in the new non-substantive rate. The additional instruction required for full qualification is to be given at the first opportunity.

(b) Any rating, who fails to qualify, will revert to the next lower non-substantive rate from the date of failure and may not be recommended for further course until twelve months after date of failure. This lower non-substantive rating may be "provisional" or "fully qualified" at the discretion of the "Authority to give rating." In the case of R.C.3(P), who fail to qualify, the provisional rate may be retained or deprived on the recommendation of "Authority to give rating" to the Commodore Superintendent of Training.

(ii) (a) Ratings, whose names appeared on the roster for advancement to leading seaman (Radar) before 17th October, 1944, will be drafted by the Commodore Superintendent of Training to H.M.A. Radar Training Establishment for a qualifying course for R.P./R.C.2. On completion, results are to be forwarded to the Commodore Superintendent of Training who will make advancements for those who qualify to leading seaman (Radar) antedating seniority to the date of first recommendation.

(b) In addition, they will be granted the provisional non-substantive rate of R.C.(P) or R.P.(P) as from 15th May, 1944, if antedated before this date, or from the date of seniority as leading seaman (Radar) if anticipated date is after 15th May, 1944.

(c) The non-substantive rate R.P. or R.C. will be granted from the date of qualifying after an R.P.2 or R.C.2 course, if the rating has not passed professionally in seamanship.

(d) If the rating has passed professionally, the non-substantive rate will be R.P.2 or R.C.2.

(iii) The rates of pay for interim rates are shown in Table C.

(iv) Every endeavour should be made to qualify ratings in plotting and fire control for R.P.3 and R.C.3 respectively at sea. Plotting and fire control courses for higher non-substantive rates must be carried out at H.M.A. Radar Training Establishment and/or Flinders Naval Depot, as the case may be.

3. All ratings shown in columns 2 and 3 of Table A, who are medically and visually fit, are required to transfer to their equivalent seaman branch rating as soon as possible. Men, who have defective colour vision or who wear glasses, are eligible for transfer if their vision is not below Standard 3. Ratings in ships should be given every opportunity to qualify in seamanship.

4. All ratings are to be qualified professionally for their equivalent seaman rating and, as soon as qualified, transfers are to be authorized by Commanding Officers and reported on Form S.161. On transfer, the non-substantive rates as shown below are to be granted:—

TABLE B.

	Substantive Rate to which Qualified.	Non-substantive Rate to be Granted.
Not Yet Qualified in Plotting—		
P.O. (Radar) R.P.(P)	a/P.O. (Tempy.)	R.P.1(P)
Ldg. Seaman (Radar) R.P.(P)	a/Ldg. Seaman (Tempy.)	R.P.2(P)
Able Seaman (Radar) R.P.(P)	Able Seaman	R.P.3(P)
Ord. Seaman R.P.(P)	Ord. Seaman	a/R.P.3(P)
Not Yet Qualified in Fire Control—		
P.O. (Radar) R.C.(P)	a/P.O. (Tempy.)	R.P.1(P)
Ldg. Seaman (Radar) R.C.(P)	a/Ldg. Seaman (Tempy.)	R.P.2(P)
Able Seaman (Radar) R.C.(P)	Able Seaman	R.C.3(P)
Ord. Seaman R.C.(P)	Ord. Seaman	a/R.C.3(P)
Fully Qualified in Plotting or Fire Control—		
P.O. (Radar) R.P.	a/P.O. (Tempy.)	R.P.1
P.O. (Radar) R.C.	a/P.O. (Tempy.)	R.C.1
Ldg. Seaman (Radar) R.P.	a/Ldg. Seaman (Tempy.)	R.P.2
Ldg. Seaman (Radar) R.C.	a/Ldg. Seaman (Tempy.)	R.C.2
Able Seaman (Radar) R.P.	Able Seaman	R.P.3
Able Seaman (Radar) R.C.	Able Seaman	R.C.3
Ord. Seaman R.C.	Ord. Seaman	a/R.C.3
Ord. Seaman R.P.	Ord. Seaman	a/R.P.3

NOTES.

(i) Transfers to Leading Seaman or Petty Officer will be made on an "acting" basis in the same manner as the remainder of the Seaman Branch except that, on confirmation, their seniority is to be antedated to their original seniority as Petty Officer (Radar) or Leading Seaman (Radar).

(ii) Ratings reverted during their acting time will be reverted to Petty Officer (Radar) R.P.(P), Leading Seaman (Radar), R.P. &c., previously held and their names reported to the Naval Board. If reverted after confirmation as Petty Officer or Leading Seaman, they will be reverted or disrated to the next lower substantive rate but are to retain their non-substantive rate provided reversion or disrating was not due to non-substantive inefficiency.

5. After final transfer to the Seaman Branch, all ratings will from then onwards be advanced in accordance with existing provisions for the Seaman Branch.

6. In no case is any rating to suffer a decrease in pay due to transfer to the new conditions of service.

7. Ordinary Seamen on transfer will only normally be entitled to an acting non-substantive rate but, in order that they should not suffer a consequent decrease in pay, they are to be paid 3d. per diem non-substantive pay continuously until rated Able Seaman.

PART II—RADAR CONTROL AND RADAR PLOT NON-SUBSTANTIVE RATES.

8. (a) The following non-substantive ratings were instituted on 15th May, 1944, and are open to Seaman ratings only:—

Radar Control Ratings—

- 1st class (R.C.1).
- 2nd class (R.C.2).
- 3rd class (R.C.3).

Radar Plot Ratings—

- 1st class (R.P.1).
- 2nd class (R.P.2).
- 3rd class (R.P.3).

(b) R.C.1 and R.C.2 are eligible for selection for Gunner's Mates under the conditions laid down in A.F.O. 627/42.

(c) R.P.1 and R.P.2 are eligible for selection for Plotting and Radar Instructor (P.R.I.) with a rate of pay of 2s. per diem. Further instructions will be issued, in due course, defining the precise duties of Plotting and Radar Instructor and the syllabus of the qualifying course.

9. For complement, qualifying service and pay purposes, the "provisional" rating during the interim period counts the same as for an equivalent fully qualified rating.

10. The standards of knowledge required, and duties, are shown in Table F of A.F.O. 5394/44. Rates of non-substantive pay and qualifications required are shown in Table D.

11. Recommendations for all R.C./R.P. courses should be forwarded to the Commodore Superintendent of Training on Form A.S.1303 with a copy to the Commanding Officer, H.M.A. Radar Training Establishment.

TABLE "C"
STATUS AND PAY OF RADAR RATINGS DURING TRANSITION TO THE R.C. AND R.P. BRANCHES.

Present Rating.	Pay per Diem.		On Receipt of this Order.	Pay per Diem.		When Qualified in Seamanship Only.	When Qualified in Fire Control or Plotting Only.	Pay per Diem.		When Qualified in Seamanship Control or Plotting.	Pay per Diem.	
	(1) Substantive.	(2) Allowance.		(1) Substantive.	(2) Allowance.			(1) Substantive.	(2) Allowance.		(1) Substantive.	(2) Allowance.
C.P.O. (Radar)	£ d. 12 6	0 3	C.P.O. (Radar) or R.C.(P) or R.P.(P)	£ d. 12 6	0 3	C.P.O. R.C.1(P) or C.P.O. R.P.1(P)	C.P.O. (Radar) R.C. or C.P.O. (Radar) R.P.	£ d. 12 6	1 0	C.P.O., R.C.1 or C.P.O., R.P.1	£ d. 12 6	1 6
P.O. (Radar)	11 2	0 3	P.O. (Radar) or R.C.(P) or R.P.(P)	11 2	0 3	P.O. R.C.1(P) or P.O. R.P.1(P)	P.O. (Radar) R.C. or P.O. (Radar) R.P.	11 2	1 0	P.O., R.C.1 or P.O., R.P.1	11 2	1 6
Ldg. Seaman (Radar)	9 8	0 3	Ldg. Seaman (Radar) R.C. (P) or Ldg. Seaman (Radar) R.P.(P)	9 8	0 3	Ldg. Seaman R.C.2(P) or Ldg. Seaman R.P.2(P)	Ldg. Seaman (Radar) R.C. or Ldg. Seaman (Radar) R.P.	9 8	0 6	Ldg. Seaman R.C.2 or Ldg. Seaman R.P.2	9 8	0 9
Able Seaman (Radar)	8 6	0 3	A.B. (Radar) or A.B. R.P.(P)	8 6	0 3	A.B. R.C.(P) or A.B. R.P.(P)	A.B. (Radar) R.C. or A.B. (Radar) R.P.	8 6	0 3	A.B., R.C.3 or A.B. R.P.3	8 6	0 3
Ord. Seaman (Radar)	5 6	0 3	Ord. Seaman (Radar) R.C. (P) or Ord. Seaman (Radar) R.P.(P)	5 6	0 3	Ord. Seaman a/R.C.3(P) or Ord. Seaman a/R.P.3(P) (see note (ii))	Ord. Seaman (Radar) R.C. or Ord. Seaman (a/Radar)	5 6	0 3	Ord. Seaman a/R.C.3 or Ord. Seaman a/R.P.3 (see Note (ii))	5 6	3

NOTES.

- (i) Existing Leading Seaman (Radar) are not required to undergo Radar Course for 2nd class rating.
(ii) The non-substantive ratings of R.C.3 and R.P.3 can only be held by Ordinary Seamen on a temporary basis; if otherwise qualified they will be confirmed on a permanent basis to A.1., but see paragraph 7 of Part I of this Order.
(iii) Only the rate of pay of a non-substantive rating is shown. The rate of pay is payable as for seaman ratings (Naval Financia Regulations and Instructions, Article 11) in the case of a re-qualifying course in gunnery after twelve months.

TABLE "D."
RADAR CONTROL RATINGS.—RATES OF NON-SUBSTANTIVE PAY AND QUALIFICATIONS REQUIRED FOR SELECTION COURSES.

155

Non-substantive Rating.	Open To.	Special Qualifications.	Where Course Carried Out.	Authority to Give Rating.	Examining Officers.	Rate per Diem.	Remarks.
R.C.1 (Radar Control Rating 1st Class)	C.P.O., P.O. and L.S. R.C.2	(a) Recommended by C.O. (b) One year's service as R.C.2 ashore or afloat (c) A total of one year's service as R.C.3 and/or R.C.2 must have been served afloat	(a) Radar (b) Gunnery School	Commodore Superintendent of Training, Flinders Naval Depot on completion of both courses	Officers of Radar and Gunnery Schools	1s. 6d.	Not payable with any other non-substantive rating except Diver. (See notes (i), (iii), and (v))
R.C.2 (Radar Control Rating 2nd Class)	L.S. and A.B. R.C.3 C.P.O. and P.O. ex R.C.3	(a) Recommended by C.O. (b) Six months' service as R.C.3 afloat or ashore. Service ashore will only count as qualifying time during the period of the present hostilities	(a) Radar School (b) Gunnery School	Commodore Superintendent of Training, Flinders Naval Depot on completion of both courses	Officers of Radar and Gunnery Schools	P.O.'s. 6d., L.S. or A.B. 9d.	Not payable with any other non-substantive rating except Diver. (See notes (i) and (ii))
R.C.3 (Radar Control Rating 3rd Class)	L.S., A.B. or Ord. Seaman	Recommended by C.O.	At sea or in Radar and Gunnery Schools	C.O. of ship or Commodore Superintendent of Training, Flinders Naval Depot	Qualified Radar and Gunnery Officers at sea or Officers of Radar and Gunnery Schools	3d.	Not payable with any other non-substantive rating except Diver or P.R.T.I.. Ordinary Seaman can only hold the Acting rating of R.C.3 and will only be paid when actually filling a vacancy in complement. (See note (iv))

6

NOTES.

- (i) Time served in the equivalent Seaman (Radar) rating or "provisional" rating counts as qualifying service for the purposes of Columns 2 and 3
- (ii) As a temporary measure, Leading Seamen and selected Able Seamen with six months' sea-going service may qualify as R.C.2 immediately after qualifying as R.C.3
- (iii) Petty Officers, R.C.1 transferred from P.O. (Radar), R.C., should carry out a re-qualifying course in the gunnery school after twelve months' combined experience as R.C.1 and P.O. (Radar), R.C., because they are unlikely on first qualifying to achieve the full standard required owing to lack of gunnery experience.
- (iv) Special pay arrangements for Ordinary Seamen, Acting R.C.3 who transferred from Ordinary Seamen (Radar) are given in paragraph 7 of Part I of this Order
- (v) The rating of R.C.1 is also open to P.O. and L.S. passed for P.O. without qualifying service as R.C.2 or R.C.3, but who have had considerable experience in fire control, e.g., senior rating in an H.A./L.A.T.S. Rate Officer, &c., and who have a high standard of intelligence.

TABLE "E."
RADAR PLOT RATINGS.—RATES OF NON-SUBSTANTIVE PAY AND QUALIFICATIONS REQUIRED FOR SELECTION FOR COURSES.

Non-substantive Rating.	Open To.	Special Qualifications.	Where Course Carried Out.	Authority to Give Rating.	Examining Officers.	Rate per Diem.	Remarks.
P.R.I. (Plotting and Radar Instructor)	C.P.O., P.O. and L.S. R.P.1 and R.P.2	Recommended by C.O.	H.M.A. Radar Training Establishment	C.O., H.M.A. Radar Training Establishment	Officers of H.M.A. Radar Training Establishment	2s.	Not payable with any other non-substantive rating except Diver
R.P.1 (Radar Plot Rating 1st Class)	C.P.O., P.O. and L.S. R.P.2	(a) Recommended by C.O. (b) One year's service as R.P.2 ashore or afloat (c) A total of one year's service as R.P.3 and/or R.P.2 must have been served afloat	H.M.A. Radar Training Establishment	C.O., H.M.A. Radar Training Establishment on completion of both courses	Officers of H.M.A. Radar Training Establishment	1s. 6d.	Not payable with any other non-substantive rating except Diver. (See note (i))
R.P.2 (Radar Plot Rating 2nd Class)	C.P.O., and P.O. ex R.P.3 L.S. and A.B. R.P.3	(a) Recommended by C.O. (b) Six months' service as R.P.3 afloat or ashore. Service ashore will only count as qualifying time during the period of the present hostilities	H.M.A. Radar Training Establishment	C.O., H.M.A. Radar Training Establishment on completion of both courses	Officers of H.M.A. Radar	P.O.'s. 6d., L.S. or A.B.'s. 9d.	Not payable with any other non-substantive rate except Diver. (See note (i))
R.P.3 (Radar Plot Rating 3rd Class)	L.S., A.B. Ordinary Seamen	Recommended by C.O.	At sea or in H.M.A. Radar Training Establishment	C.O. of ship or C.O. of H.M.A. Radar Training Establishment	Qualified Radar and Fighter Direction or Navigating Officers at sea, or Officers of H.M.A. Radar Training Establishment	3d.	Not payable with any other non-substantive rating except Diver or P.R.T.I.. Ordinary Seamen can only hold the acting rating of R.P.3 and will only be paid when actually filling a vacancy in complement. (See note (ii))

7

NOTES.

- (i) Time served in the equivalent Seaman (Radar) rating or "provisional" rating counts as qualifying service for the purposes of Column 3.
- (ii) Special pay arrangements for Ordinary Seaman, Acting R.P.3 who transferred from Ordinary Seaman (Radar) are given in paragraph 7 of Part I of this Order.

(This Order will be reprinted for posting on Notice Boards.)

(348/218/1.)

155

156.

**RADIO MECHANIC BRANCH—ADVANCEMENT TO PETTY OFFICER
RADIO MECHANIC (S).**

Navy Order 360 of 1944 is no longer applicable to Radio Mechanics (S), whose advancement is to be governed by the rules hereunder:—

Advancement.—(a) Leading radio mechanics (S) may be advanced to petty officer radio mechanic after serving a minimum time of one year's combined service as a leading radio mechanic, and leading wireless mechanic, provided that they—

- (i) are recommended by Commanding Officers as being suitable to hold a petty officer's rate;
- (ii) pass a practical technical examination conducted by a qualified signal officer, radar officer, commissioned or warrant telegraphist (or officer promoted therefrom)—the passing percentage required being the same as that for a petty officer telegraphist.

(b) The standard of technical proficiency required is to be comparable to that laid down in A.F.O. 885/43 for W/T2 technical practical, for equipment installed in shore stations and light craft for which petty officer radio mechanics (S) may be responsible as base maintenance and fitting-out staff. (See paragraph 2.)

(c) Leading radio mechanics (S) who have already been advanced under the provisions of Navy Order 360 of 1944 are to re-qualify by passing the above examination—the date of confirmation being back dated to their original seniority as petty officer radio mechanic if successful.

2. As small craft and shore W/T stations are not fitted with Admiralty equipment, the following table substitutes W/T technical table shown on page 20 of A.F.O. 885/43.

Standard Sets or Equipment.	First Alternative.	Second Alternative.	Standard.
Transmitting—			
A.W.A. 500 Watt H/F (A T 13)	A.W.A. 1,000 watt H/F	Any other A.W.A. or S.T.C. 500 watt or 1,000 watt type	A
S.T.C. 20 K.W. H/F ..	A.W.A. 10 K.W. H/F	..	B
A.W.A. 1½ K.W. H/F ..	S.T.C. 14S. H/F	B
S.T.C. 200 K.W. L/F	C
Receiving—			
S.T.C. Group 2A (H/F) (A679)	Any service H/F or L/F receiver	Any communication receiver	A
Measuring Instruments—			
Wave meter G61/62 ..	A.W.A. absorption type	..	A
Avometer	A
Valve testers	A
Standard condenser tester and capacity bridge	A
Megger	A
Use of ordinary workshop tools	A
Keying Systems (in own Station)	A

SIGNIFICATION OF LETTERS.

Letter.	Transmitting Sets.	Receiving Gear.	Measuring Instruments.
A	(i) Detailed knowledge of circuits and their operation (ii) Complete knowledge of care and maintenance requirements (iii) Locating faults and method of repair (iv) Tuning (v) Detailed knowledge of various methods of feeding RF power to an aerial system (vi) Rewiring of a selected component of the transmitter	(i) Detailed knowledge of circuits and their use (ii) Maintenance tests (iii) Locating any faults and method of repair (iv) Detailed knowledge of aligning a Receiver with the aid of a signal generator and output meter of oscillograph (v) Rewiring of a selected component of the receiver	(i) Complete knowledge of the use and application of each instrument
B	(i) Good knowledge of the transmitter and ability to locate faults (ii) Care and maintenance requirements (iii) Tuning		
C	(i) Brief knowledge of transmitter, i.e., its power rating, frequency range, method of keying, type of valves used, and rough idea of layout		

3. Navy Order 360 of 1944 remains the authority for advancement of leading radio mechanics (W) to petty officer radio mechanic (W).

(549/110/124.)

157.

ROYAL NAVY PERSONNEL IN AUSTRALIAN SERVICE HOSPITALS.

The following procedure is to be adopted in respect of Royal Navy and Royal Marine personnel who undergo treatment in Australian Service Hospitals.

2. All casualties which have been caused by enemy action should be reported to Vice-Admiral (Q), British Pacific Fleet, stating the nature of the injury and whether dangerous, serious or slight.

3. All seriously and dangerously ill cases, and deaths, should be reported to the Vice-Admiral (Q), British Pacific Fleet. The diagnosis, and a weekly statement of progress, should also be communicated in the case of seriously or dangerously ill personnel.

4. The Vice-Admiral (Q), British Pacific Fleet, should be notified when an officer is admitted to hospital together with the diagnosis and estimated time during which the officer will be unfit for duty. Discharges from hospital should be notified similarly and the disposal of the officer given.

5. On the discharge of patients from hospital, a resumé of the case notes should be forwarded to the Vice-Admiral (Q) British Pacific Fleet.

6. The address of the Vice-Admiral (Q), British Pacific Fleet, is R.N. Headquarters, "M" Block, No. 1 Area, Albert Park, Melbourne. Telephone MXY 130 (Staff Medical Officer, Extension 6733).

(429/201/895.)

(This Order will be printed for posting on Notice Boards.)

158.

PERSONNEL DISCHARGED TO HOSPITAL IN SYDNEY.

Where a member is discharged to hospital in Sydney and it is apparent that his ship will not have a prolonged stay in port, his account, service papers, kit-bag, hammock, bedding and anti-gas respirator are to be forwarded to the parent ship of the hospital *immediately* on discharge.

2. C.O.R., Article 245, will be amended as necessary.

(584/215/96.)

159.

BRITISH—U.S. COMMUNICATION FLAGS.

With reference to Navy Order 557 of 1943, the allowances of U.S. Signal Flags referred to therein have been revised, and are to be in accordance with the present Establishments of British Flags. Only the flags necessary to bring the British sets up to American sets are to be demanded.

Particulars of the revised allowances are as follows:—

H.M.A. Ships or Establishments.	Size of Flags.	Quantity.
		Sets
Cruisers	3	4
Platypus	3	4
L.S. Is.	3	2
Destroyers (Tribals)	3	4
Destroyers (other than Tribals)	4	2
Moresby	3	2
Sloops	4	2
Frigates	4	2
A.M.S. Vessels	4	1
Examination Vessels	3	1
Boom Vessels	5*	1
Boom Working Vessels	5*	1
Aux. A/S and M/S Vessels	5*	1
Tugs	4	1
M.Ls. (all types)	5*	1
Naval Depots and Bases	4	2
Port War Signal Stations	2*	1
War Signal Stations	3	1
Signal Stations	3	1

NOTE.

* U.S.N. signal flags are manufactured in three sizes only, which approximate Admiralty sizes 3, 4 and 6. H.M.A. Ships and Establishments normally carrying size 5 Admiralty Flags should be supplied with size 4 U.S. Flags, and those normally carrying size 2 Admiralty Flags should be supplied with size 3 U.S. Flags.

2. The flags and pennants to be used in flag-hoist signalling are shown in plates 2—7 and 3—7 of Communication Instructions (DNC.5) and their detailed dimensions in U.S. standard sizes are given in the appendix to the Flag Book (H.O.89).

3. Flags common to British—U.S. usage are:—

- (a) Blue Flag.
- (b) Screen Flag (Pilot Jack).
- (c) Black Pendant.

The U.S.—British Flag "BUS" should be retained on board.

4. H.M.A. Ships and Establishments are to forward demands to the Superintending Naval Store Officer, Sydney, for U.S. Flags necessary to complete to the above-mentioned allowances. Supply will be effected in the following order of priority as soon as stocks become available:—

- (1) Silo Signal Station, Fremantle.
- (2) H.M.A. Ships (including Auxiliary Vessels) in forward areas.
- (3) Port War Signal Stations.
- (4) War Signal Stations.
- (5) Signal Stations (other than (1)).
- (6) H.M.A. Naval Establishments.
- (7) H.M.A. Ships (including Auxiliary Vessels) other than (2).

(476/201/711.)

160.

SIGNALS—INDICATIONS OF PRECEDENCE AND THEIR USE.

United States Indications of Precedence have been adopted in the South-West Pacific Area, in accordance with A.C.N.B. 270504 January. It is apparent that their correct usage is not widely understood.

2. The following remarks are intended as a guide to all concerned, but particularly to originators of signals. Full instructions are contained in D.N.C. 5 (Communication Instructions) Article 2012, 6263 (not yet held by all authorities).

(a) Operational or Administrative Traffic.

- (i) In wartime it is necessary to handle operational traffic ahead of all administrative traffic, regardless of the relative precedence assigned.
- (ii) This means that originators must decide in regard to every signal, whether it is *Operational* or *Administrative*. In most cases this decision presents no difficulty, but instances will arise where there is doubt where the line should be drawn. In such cases the general urgency of the message and its bearing, if any, on the successful prosecution of an operation should be borne in mind.

(iii) The Operating Signal QPE.

This Operating Signal, meaning "This is an *Operational* message", is provided to enable the division between *Operational* and *Administrative* traffic to be made by the originator, in such a form that it will be instantly noticeable to all who handle the traffic.

It is the responsibility of *Originators* to place QPE on message forms immediately after the precedence. All signals (except O and OP messages: see (b) (iii) below) which originators decide are *Operational* rather than *Administrative*, must therefore bear QPE.

The marking of signals "QPE" must not be left to the communication ratings, or other persons concerned with the handling of messages. The decision lies with the originator only. "QPE" forms a definite part of the *Precedence* of the message.

(b) Rules for the Order of Precedence.

- (i) All *Operational* traffic precedes *Administrative* traffic.
- (ii) The highest precedence allowed to *Administrative* traffic is *Priority*.
- (iii) It is therefore unnecessary to distinguish *Operational* traffic, of precedence enemy contact *Urgent* and *Operational* *Priority*, by the operating signal QPE, as *Administrative* traffic never bears these indications of precedence.

(c) Degrees of Precedence.

- (i) There are therefore virtually nine degrees of precedence, viz. :—

Operational Traffic.	Order of Precedence.	Signification.	Symbol.
Operational Traffic	1	Enemy Contact* ..	O.U.*
	2	Urgent	O.
	3	Operational Priority	O.P.
	4	Priority—QPE ..	P—QPE
	5	(Routine)—QPE ..	QPE
	6	Deferred—QPE ..	D—QPE
Administrative Traffic	7	Priority	P.
	8	Routine	(R)†
	9	Deferred	D.

* Only for use within U.S. Navy.

† Only used in multi-precedence messages.

- (ii) The effect of leaving QPE off a message is seen from the following example:—

An *Operational* message designated *Priority* should be 4th *Precedence*, but if QPE is omitted, it is automatically degraded to 7th *Precedence*.

(d) Message Handling.

All sections of the communication branch are to ensure that traffic is handled strictly in accordance with the above degrees of precedence.

(2037/2/1352.)

161.

MERCUROUS GREASE—NOT TO BE USED WITH BRASSES AND BRONZES.

Attention is directed to A.F.O. 4645/42 which refers to the prohibition of the use of greases containing mercury with any brass or bronze articles subject to stress, owing to the tendency of the mercury to develop season cracking in these materials.

2. The propeller nut of an A.M.S. vessel was recently found to be seriously cracked, and on investigation it was found that a mercurous grease had been used in the nut at the previous docking.

3. Ships' officers and base staffs are to ensure that the provisions of A.F.O. 4645/42 are strictly observed, and unless it is definitely known that mercurous grease was not applied at the previous docking, all (brass) propeller nuts are to be removed for examination on each occasion of docking. If traces of mercurous grease are found, the propeller should also be drawn for thorough cleaning and examination for any signs of cracking.

4. The mercurous grease can be readily identified by its bluish-grey colour and its characteristic smell.

(545/201/547.)

162.

SEASICKNESS TABLETS—ISSUE TO SERVICE AFLOAT.

It has been established that hyoscine is the most effective substance available as a seasickness remedy.

2. Given by the mouth in the form of hyoscine hydrobromide, gr. 1/100, as a prophylactic measure, it can be expected to reduce the incidence of seasickness by 50 per cent. without producing deleterious side effects or reducing fighting efficiency. It can be repeated in doses of gr. 1/200 at intervals of six hours for a maximum period of 48 hours.

3. *As it reduces sweating, it should be used with caution where there is a danger of heat exhaustion or heat stroke.*

4. The prophylactic dose of gr. 1/100 should be taken, if possible, one hour before rough weather is expected.

5. The drug will be issued in "oral" tablets containing gr. 1/200 of hyoscine hydrobromide. (Directions for use, *vide* paragraph 2.)

6. The tablets will be supplied to all ships afloat and will be issued on the directions of the medical officer except where no such officer is borne, when the tablets will be under the charge of and issued by the commanding officer, who is to ensure that the drug is stored under lock and key.

7. The tablets will be issued on the following scale to the service afloat only:—

SCALE AFLOAT.

Unit.	Number of Personnel.				Scale "C."
	100 to 300.	300 to 500.	500 to 700.	700 and Above.	
1,000's ..	$\frac{1}{2}$	$\frac{1}{2}$	$\frac{1}{2}$	1	$\frac{1}{2}$

The scale is to be amended accordingly.

8. All new units supplied should contain the requisite number of tablets, and medical and commanding officers of ships already carrying units of medical stores should demand supplies from the most convenient issuing medical store depot.

9. R.A.N. Medical Technical Instruction *re* Seasickness, already issued to Medical Officers, will be issued from Navy Office to the commanding officers of all small vessels not carrying a medical officer.

(612/213/2842.)

163.

REPAYMENT CLOTHING FOR TENDERS.

In addition to the maintenance of an emergency stock of specified clothing as set out in (A) below, it is now approved that the immediate requirements of any tender for repayment articles of clothing, when available in a victualling store issuing ship, may be drawn on a cash basis in accordance with the procedure set out in (B) below.

(A) Maintenance of Emergency Stocks of Specified Items in Certain Tenders.

- (i) For the remainder of the war period, destroyers, frigates, sloops and A.M.S. vessels, when operating in forward areas (including Northern Territory), may maintain, for emergency issue on repayment, a limited quantity of each of the following articles, in addition to soap and cap ribbons only which have hitherto been authorized:—

Boots, leather.	Stockings.
Brushes, tooth.	Shorts, khaki.
Caps, white duck.	Shirts, khaki.
Shoes, black leather.	Towels, white.
Singlets.	Cap covers, khaki.
Socks.	Suits, combination.

- (ii) The maximum quantities to be maintained are not to exceed one month's estimated requirements of each article, and issues should be confined to occasions when individual requirements are not obtainable from the parent ship, or other H.M.A. ship or naval establishment where a supply officer is borne, or from a victualling store issuing ship. To guard against deterioration in small ships, however, all articles in store should, as a general rule, be issued within three or four months from date of receipt.

- (iii) Commanding officers concerned are to ensure that such stores are placed in a suitable secure stowage space. They will be directly responsible for the safe custody of, and satisfactory accounting for, such stores (*vide* K.R. & A.I., Article 1853A) and that, where applicable, the general procedure specified in C.O.R., Article 481, is observed. In this regard, Form A.S.1048 is to be used as a credit voucher in Form A.S.462 (Parts II and III) thereby dispensing with Form A.S.107. As far as is possible, issues should be restricted to urgent requirements and then only in the circumstances stated in paragraph (ii) above. Cash takings for sales recorded in Form A.S.1048 are to be paid by commanding officers at the first opportunity to the supply officer of any H.M.A. ship or establishment, the official receipt obtained being affixed to the credit voucher (Form A.S.1048). The cash taken for sales of clothing is not to be left in the custody of the supply rating after an issue has taken place. It is to be handed over on the same day to an officer for custody, and should be checked by an officer with Form A.S.1048 to ensure that the correct charge is made for each item and that the gross total is correct. The form should be signed by the supply rating making the issue and by the officer receiving the cash.
- (iv) Stocks of repayment clothing are to be checked at least once a month, and a monthly certificate of stocktaking is to be signed by the commanding officer, or officer delegated by him for victualling duties, and attached to Form A.S.462 (Parts II and III) for subsequent rendition to Navy Office. In this connection, opportunity is to be taken by parent ships for stocktaking to be carried out in accordance with paragraph 3 of Navy Order 373 of 1941.
- (v) The necessary forms should be obtained by demand in the usual manner, or in an emergency from the supply officer of a ship or establishment. Additional copies of the clothing price list are, if required, to be obtained from the Director of Victualling, Navy Office.
- (vi) When a demand is made on a victualling store issuing ship for articles of clothing to create or complete the approved emergency stock in a tender, supply and receipt notes are to be passed in the normal manner, no cash being collected for such transactions.

(B) Requirements of Repayment Clothing of Tenders when available from a Victualling Store Issuing Ship.

- (i) The normal clothing requirements for immediate use by personnel of any tender (including those holding an emergency stock of repayment articles), when available from a victualling store issuing ship, are to be issued separately for cash only, the following detailed procedure being observed:—

- (1) The tender concerned is to prepare a nominal list, in duplicate, showing the specific articles required by each person, sizes and fittings being indicated as necessary.

- (2) The nominal list is to be approved by the commanding officer, if he is satisfied that supply is necessary, and forwarded, in duplicate and by hand, to the deputy victualling store officer of the victualling store issuing ship concerned together with the total cash involved.
- (3) Supply of such repayment requirements available is then to be effected in bulk for issue to individuals in the tender, and the cash received brought to account in the issuing ship. The original nominal list approved by the commanding officer is to be attached to the official receipt as a supporting voucher to the victualling store issuing ship's cash account and the official receipt number noted on both copies of the nominal list. The duplicate copy is to be returned to the commanding officer for his information and transmission by first available post direct to the Director of Victualling, Navy Office.
- (4) Any articles not available for issue are to be deleted from both copies of the ship's nominal list, and cash concerned returned to the tender.

2. In regard to (A) and (B) above, it will be seen that it is intended, when any tender contacts a victualling store issuing ship in forward areas, that the normal clothing requirements of the ship's company shall be drawn, whenever possible, from the issuing ship and for cash only. At the same time, however, any authorized emergency stock maintained on board should, if necessary, be replenished to the approved quantity by normal supply and receipt notes in accordance with (A) above, no cash collections being effected.

3. The procedure set out in (A) and (B) above is not intended to restrict in any manner the normal procedure by which tenders now obtain, as opportunity offers, their requirements of repayment clothing from H.M.A. ships or establishments which they may contact from time to time.

4. Navy Orders 664 of 1943 and 492 of 1944 are cancelled.

(434/201/3523.)

164.

A.C.F. CLUB FOR WOMEN OFFICERS—SYDNEY.

The attention of officers of the Royal Australian Naval Nursing Service and Women's Royal Australian Naval Service is drawn to the announcement that a club for women officers has been established by the Australian Comforts Fund, New South Wales Division, at No. 4 Elizabeth Bay-road, Elizabeth Bay, Sydney.

2. The club is available to all women of commissioned rank and provides sleeping accommodation for 35 persons nightly.

3. Meals for non-resident officers are also available at moderate charges. The telephone number is FL 1613.

4. The tariff for bed and breakfast is 4s.

(462/201/2328.)

165.

MOTOR VEHICLE REAR VISION MIRRORS.

Instances have occurred recently where accidents in which naval motor vehicles were involved were primarily due to the non-effectiveness of the rear vision mirror. In each instance, the mirror was mounted on the inside of the windscreen and the driver's view was obscured by an obstruction on the rear portion of the vehicle.

2. With a view to avoiding such accidents in future, all motor trucks which normally carry high loads and vehicles fitted with gas producers or other fittings liable to obscure the driver's view in internally fitted rear vision mirrors are to be provided with an additional external mirror providing a clear view under all conditions.

3. Particulars of vehicles in which an additional mirror is fitted in accordance with this Order should be forwarded to Navy Office in order that vehicle fixture lists may be amended as necessary.

(638/202/1987.)

RESTRICTED.(FOR OFFICIAL USE ONLY.)**Commonwealth Navy Orders.**

Navy Office, Melbourne,

1st May, 1945.

The following Orders, having been approved, are hereby promulgated for information and guidance, and necessary action.

By direction of the Naval Board,

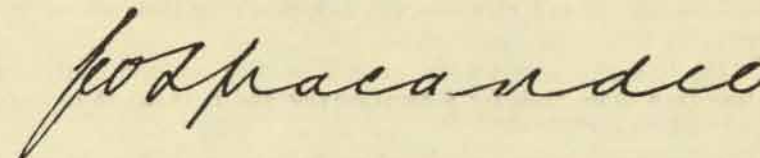

Secretary.

*The Commodore Commanding H.M.A. Squadron,
and Commanding Officers of H.M.A. Ships,
Officers in Charge of H.M.A. Naval
Establishments, and others concerned.*

TABLE OF CONTENTS.

No.	Subject.
166.	Port Directors.
167.	Stores Ratings (A.S.).
168.	Hawsers for A.M.S. Vessels.
169.	Magazine Logs.
170.	Badar Outfits J.E.—P.P.I. Ventilation—Alterations and Additions.
171.	Dental Treatment of Royal Naval Personnel.
172.	Supply of Spectacles—General Conditions.
173.	Kerosene Cooking Stoves in Small Craft.
174.	Tins, Baking, Bread.
175.	General Messing in Small Ships—Supply of Stainless Steel Trays.
176.	Machinery Spares—Organization for the Provision, Storing, Supply and Accounting for Main Auxiliary Engines and Spare Gear.
177.	Hospitality for Personnel on Leave at Sydney—Command Amenities Liaison Officer.
178.	Naval, Military and Air Force Club, Adelaide.

166.

PORT DIRECTORS.

With reference to Navy Order 425 of 1944, a Royal Australian Navy Port Director was appointed at Aitape, New Guinea, on 30th March, 1945.

(1937/2/302.)

167.

STORES RATING (A.S.).

It has been decided, as a temporary war measure, to adopt the rating of Stores Rating (A.S.) to meet requirements in the various Armament Stores and Armament Store Issuing Ships.

2. Rating will be open only to personnel serving under R.A.N.R., or R.A.N.V.R., engagements.

3. (a) Stores ratings R.A.N.R. and other R.A.N.R. or R.A.N.V.R. personnel will be allowed to transfer to the new rating subject to recommendation and vacancies existing, retaining their present relative rate.

(b) Transfer is not open to men holding non-substantive ratings other than those unfit for general service and is in all cases subject to manning requirements.

4. As the positions to be filled are mainly in northern bases, ratings must be medically fit for tropical service.

5. Direct entries from shore will be in the rating of Stores Probationer (A.S.).

6. *Advancement.*

Stores Probationer (A.S.) to Stores Assistant (A.S.).

Probationary time to be a minimum period of three months including four weeks' training at Spectacle Island. Advancements to be made on completion of probationary period.

Stores Assistant (A.S.) to Leading Stores Assistant (A.S.).

(a) Authority to give rating—Naval Officer-in-Charge, Flinders Naval Depot.

(b) Nine months' service as Stores Assistant (A.S.) not including probationary time.

(c) Certificate of proficiency in A.S. duties.

(d) Recommended on Form A.S. 507.

Leading Stores Assistant (A.S.) to Stores Petty Officer (A.S.).

(a) Authority to give rating—Naval Officer-in-Charge, Flinders Naval Depot.

(b) Twelve months' actual service as Leading Stores Assistant (A.S.).

(c) Certificate of proficiency in A.S. duties.

(d) Recommended on Form A.S. 507.

All advancements to be on a temporary basis.

7. Rates of pay to be those as laid down in Naval Financial Regulations and Instructions for Supply (or Stores) Branch.

8. Applications for transfer are to be dealt with in accordance with Navy Order 251 of 1943, including recommendation, stating time served in Armament Store duties.

9. Time served actually performing the duties in Armament Store prior to transfer to Supply or Stores Assistant (A.S.) may be counted as service as Stores Assistant (A.S.) for advancement purposes. In exceptional cases, ratings who possess special qualifications but who do not comply with the conditions of paragraph 6 above may, subject to Naval Board approval, be advanced to Leading Stores Assistant (A.S.) and/or Stores Petty Officer (A.S.).

10. In the event of a rating's being transferred from Armament Store duties, he is to be automatically reverted to the rating held immediately prior to transfer to Supply or Stores Assistant (A.S.); direct entries from shore are to be reverted to Stores Assistant.

11. Navy Order 17 of 1944 is cancelled.

(568/202/1035.)

(This Order will be reprinted for posting on Notice Boards.)

168.

HAWSERS FOR A.M.S. VESSELS.

It has been decided to supply a longer and stronger hawser to A.M.S. Vessels for use when engaged in towing operations.

2. Supply of a 3½-in. x 150 fathoms Steel Wire Hawser will, therefore, be effected without demand by the Superintending Naval Store Officer, Sydney, as soon as stocks become available.

3. The under-mentioned wires at present carried in A.M.S. Vessels are to be landed on receipt of the above-mentioned steel wire hawser:—

Description.	Qty.
3 in. x 100 fathoms steel wire hawser	1 No.
3½ in. x 100 fathoms steel wire hawser	1 No.

4. The revised allowances of all hawsers to A.M.S. Vessels are summarized hereunder:—

Description.	Qty.	Remarks.
2½ in. x 150 fathoms steel wire hawser	1 No.	Allowed vide B.R. 368 Admiralty Establishment of Naval Stores for Minesweepers, &c.
2½ in. x 90 fathoms steel wire hawser	1 No.	Special allowance
3½ in. x 150 fathoms steel wire hawser	1 No.	Special allowance

(2026/14/544.)

169.

MAGAZINE LOGS.

With reference to B.R. 862, Naval Magazine and Explosives Regulations, Article 82, Magazine Logs as indicated below are to be used in H.M.A. Ships:—

S.285A, Part I—Cruisers.

S.285A, Part II—Cruisers; until Form S.285A (S) becomes available.

S.285B.—Destroyers, Sloops, Frigates, and H.M.A.S. *Platypus*.

S.285F.—A.M./S., Surveying, Auxiliary, and Boom Vessels.

(659/203/722.)

170.

RADAR OUTFITS J.E.—P.P.I. VENTILATION—ALTERATIONS AND ADDITIONS.

The provisions of A.F.O. 5918/44 will apply in principle in the R.A.N.

2. Where a ventilation exhaust is available in the same compartment as the P.P.I., the exhaust trunking is to be suitably extended to provide an exhaust for the display unit.

3. When no convenient exhaust ventilating system is available, an electric blower type "F.W. Davey," 240V. AC/D.C., is to be fitted. Blowers will be supplied where required on demand from the Superintending Naval Store Officer, Sydney.

4. Ships concerned are to arrange for the alterations to be done by ship's staff or base repair staff. Where the modifications to ventilation trunking are beyond these resources, dockyard assistance may be obtained, the work being treated as a defect in existing arrangements.

(2037/7/1256.)

171.

DENTAL TREATMENT OF ROYAL NAVAL PERSONNEL.

With reference to C.O.R., Article 591, the following schedule of fees, for recovery from the Royal Navy of costs of dental treatment, prosthetic work, repairs and X-rays, is notified:—

<i>Dental Treatment.</i>	£ s. d.
(a) Scaling and treatment of the gums, per individual	0 7 6
(b) <i>Fillings</i> .—Per filling (limited to 15s. per tooth for two or more fillings)	0 7 6
(c) <i>Root Treatment</i> .—Six front teeth, upper or lower, per tooth	0 5 0
Remainder, upper or lower, per tooth	0 7 6

(d) Extractions—

	£ s. d.
(i) Per tooth	0 2 6
Maximum fee for upper or lower	0 15 0
Maximum fee for upper and lower	1 5 0
(ii) General anaesthetic—	
Administration fee—	
For upper or lower extractions	0 7 6
For upper and lower extractions	0 10 0

Prosthetic Work.**(a) New Dentures.**

(i) Full, or nearly full (ten teeth or more per denture)—	
Upper and lower dentures	6 0 0
Full or nearly full (ten teeth or more)—	
Upper or lower denture	3 0 0
(ii) Partial dentures—	
For the first two teeth on denture	1 0 0
For each additional tooth	0 5 6

(b) Remaking Dentures.—Fees to be calculated at two-thirds of the scale, with necessary additional teeth at 5s. per tooth—

Maximum fee, including additional teeth, per denture	2 10 0
--	--------

Repairs.

Minimum fee for repairs and for additions	0 7 6
Maximum fee for repairs and for additions	1 10 0

X-rays.

For each film up to two in number	0 7 6
Three or more films	1 1 0

2. The statement and return of valued forms, required by paragraph 4 of C.O.R., Article 591, should be forwarded to Navy Office monthly.

3. Navy Orders 237 of 1930 and 57 of 1935 are hereby cancelled.

(527/211/2164.)

172.

SUPPLY OF SPECTACLES—GENERAL CONDITIONS.

The following conditions relating to the supply of spectacles at Service expense are consolidated from various previous instructions and are to be adhered to in all cases.

2. (a) Reading Spectacles—

Glasses for reading may be supplied at the public expense to ratings of all branches irrespective of the age of the ratings, when recommended by an ophthalmic specialist.

(b) Spectacles for Constant Wear—

Ratings (including W.R.A.N.S.) with the exception of those shown below (*vide (b) (i)*) are permitted to wear spectacles constantly and may be supplied with them at the public expense, when recommended by an ophthalmic specialist.

(i) The following ratings are not permitted spectacles for constant wear:—

Seaman ratings for general service (*vide (b) (ii)*).
Signal ratings for general service.
Stokers and leading stokers.
W.R.A.N. visual signallers.

(ii) Seaman ratings on shore duties only and in immobile gate vessels (boom defence) may wear glasses constantly and be supplied at the public expense, when recommended by an ophthalmic specialist.

The following seaman ratings:—Q.O. (in Cruisers and above), Radar, S.D., S.T.—may wear glasses at their specialist work, and be supplied at public expense, when recommended by an ophthalmic specialist.

3. Officers of the Naval Forces (including the Women's Services of the R.A.N.), and members of the Auxiliary Services other than the Shore Wireless Service, are *not* entitled to the supply of spectacles at public expense unless spectacles are lost or damaged as a result of a casualty of the Service. The prescription for spectacles may, however, be loaned to these members in order that purchase may be arranged privately.

4. Approval for supply of spectacles is in each case to be obtained on Form A.M. 250z subject to supply being recommended by an ophthalmic specialist who should indicate whether the spectacles are required for near or distant vision. As a wartime measure, authority has been delegated to Naval Officers-in-Charge in each State of the Commonwealth for the grant or refusal of spectacles where the proposed supply is in accordance with the conditions contained hereunder. Form A.M. 250z is to be prepared in each case and submitted to the Naval Officer-in-Charge, who, if the supply is in order, will approve and sign the form in lieu of the Director of Naval Medical Services. At the end of each month, the forms A.M. 250z for those spectacles supplied during the month are to be forwarded to the Director of Naval Medical Services.

5. The supply of spectacles at Service expense is to be arranged through the qualified opticians under contract with the Department, and in accordance with the terms of the contract unless unnecessary delay would occur in adopting this procedure. In such instances, the commanding officer is to make satisfactory local arrangements for supply by a qualified optician and is to satisfy himself that the price is reasonable, having due regard to the prices obtaining in the district where the purchase is made.

6. Seaman ratings with sea experience who are found to be below the proper visual standard should not be relegated to shore service if this can be avoided. As an alternative, application should be made for their employment or transfer as follows, in the order given:—

- (a) Qualification as an S.D. Operator, S.T., for service in cruisers, and above. Q.O., Radar, or for training as an electrical, engine room, ordnance artificer or motor mechanic. These ratings, with the exception of S.D. Operators, are permitted the constant wearing of spectacles on duty. S.D. ratings may wear spectacles on duty only when in cabinets.
- (b) Transfer as seaman to boom defence service, i.e., for draft to immobile gate vessels and shore service only.
- (c) Transfer for further sea service to any other branch in which the constant wearing of spectacles is permitted.

It is the intention that each case should be judged on its merits. Transfer to the Supply Branch should be avoided unless for some reason in a limited number of cases the men concerned are particularly suitable for such a transfer. It should be noted that the spectacles supplied under this paragraph should correct to at least 6/6 6/9.

7. Experienced ratings, whose vision has been found to be below that required for their particular rating, but is corrigible to normal with the aid of glasses, and who, in the opinion of the Board of Survey, are capable of carrying out any of the duties mentioned in paragraph 6 (a) of this Order or of being transferred to any other branch, are to be placed in Category "B" for drafting purposes and not in Category "E." A notation of his defect is to be placed in each rating's Medical History Documents.

8. In all cases where any doubt exists as to a member's eligibility for spectacles at Service expense, the matter is to be fully reported to the Director of Naval Medical Services and his approval obtained before any action is taken to arrange supply.

9. Navy Order 33 of 1945 is cancelled.

(527/201/985.)

173.

KEROSENE COOKING STOVES IN SMALL CRAFT.

An accident has occurred aboard a small craft fitted with a kerosene cooking stove, resulting in a rating's receiving severe burns, which later proved fatal.

2. The burner of the stove had been heated by means of the priming cup in readiness for starting up, but the flame in the primer had died down before the burner was sufficiently hot to vaporize the kerosene. The operator attempted to reprime the cup by pouring the methylated spirit from an old quart grease tin which was used as a container for the priming fuel. The container exploded and the rating received very severe burns, which later caused his death.

3. Too much stress cannot be laid upon the necessity for exercising every care in connexion with the operation of kerosene stoves.
4. The following instructions are to be observed:—
 - (a) The bulk supply of methylated spirit, used for priming, is not to be kept in the galley.
 - (b) Only sufficient fuel for one priming is to be taken into the galley, in a suitable small container, and, before attempting to reprime, the operator is to satisfy himself that no trace of flame or smouldering carbon remains around the burner.
 - (c) The burner is not to be used if the flame produced is not of a clear blue colour.
 - (d) Connexions between the fuel tank and burners are never to be uncoupled without first releasing the air pressure from the fuel tank.
 - (e) Cooking utensils and stoves are to be kept scrupulously clean, and the spilling of fat is to be avoided.
5. Commanding Officers are to warn crews of the dangers associated with the use of kerosene cooking stoves, and are to ensure that vigilance is exercised at all times in connexion with their use.

(432/222/1450.)

174.

TINS, BAKING, BREAD.

Demands for tins, baking, bread, for H.M.A. ships and establishments are, in future, to be restricted as far as possible to the sizes shown hereunder, stocks of which are maintained at Royal Edward Victualling Yard, Sydney, and at H.M.A. Naval Victualling Depots:—

Pat. No.	Nominal Size.	External Dimensions.		
		Top.	Bottom.	Depth.
		Inches.	Inches.	Inches.
283	4 lb.	9 $\frac{3}{4}$ x 6 $\frac{3}{8}$	7 $\frac{3}{4}$ x 4 $\frac{7}{8}$	4 $\frac{1}{8}$
284A	2 lb.	7 $\frac{3}{4}$ x 4 $\frac{3}{8}$	6 $\frac{1}{2}$ x 3 $\frac{3}{8}$	4 $\frac{1}{4}$
285A	24 in.	24 $\frac{3}{4}$ x 6 $\frac{3}{8}$	22 $\frac{1}{16}$ x 4 $\frac{1}{4}$	4 $\frac{11}{16}$
286A	18 in.	17 $\frac{3}{4}$ x 5 $\frac{7}{8}$	16 x 4 $\frac{1}{16}$	4 $\frac{3}{4}$
288	Round	7 $\frac{1}{4}$ in. diameter	6 $\frac{1}{4}$ in. diameter	2 $\frac{1}{4}$

2. Where it is necessary to demand any size other than those shown above, the reason is to be stated on the demand.

(530/202/466.)

175.

GENERAL MESSING IN SMALL SHIPS—SUPPLY OF STAINLESS STEEL TRAYS.

With reference to paragraph 3 of Navy Order 626 of 1944, owing to the urgency of obtaining adequate initial supplies of stainless steel food trays to meet the immediate requirements of H.M.A. Ships in which general messing with the cafeteria method of food service is being installed, it has been necessary to accept first deliveries of those trays in an unpolished condition.

2. Such trays, when received from a victualling yard or depot, can be suitably polished on board and a satisfactory finish is obtainable by the use of a fine emery cloth.

3. The more appetising appearance of food on polished trays renders it most desirable that polishing should be effected on board before, or as soon as possible after they are brought into use and it is intended that action be taken accordingly by each ship concerned, when practicable.

4. Subsequent deliveries of these trays will be made from properly polished sheet metal which will render unnecessary any polishing after receipt on board. Previous supplies of unpolished trays will then be replaced as opportunity offers.

(530/202/475.)

176

MACHINERY SPARES—ORGANIZATION FOR THE PROVISION, STORING, SUPPLY AND ACCOUNTING FOR MAIN, AUXILIARY ENGINES AND SPARE GEAR.

Navy Order 666 of 1944 is to be amended by adding to Appendix "A" the following:—

Liners
Blower Assemblies
Reduction and Reverse Gear Assemblies
Cylinder Block
Flexible Couplings
Silencers.

(549/201/148.)

177.

HOSPITALITY FOR PERSONNEL ON LEAVE AT SYDNEY—COMMAND AMENITIES LIAISON OFFICER.

Officers and ratings of the Royal Australian Navy proceeding on leave to Sydney are advised that there is a Command Amenities Liaison Officer on the staff of Flag Officer-in-Charge, Sydney.

2. Personnel who desire to avail themselves of hospitality offered by private persons during leave periods are invited to notify the Command Amenities Liaison Officer in advance, stating the period for which accommodation is required, and whether city, country, or seaside is preferred. Arrangements will then be made, if possible, to obtain accommodation required. Wives and families cannot be catered for.

3. When such arrangements have been made at the request of naval personnel, it is obviously necessary that they should be adhered to, except in very special circumstances.

(462/201/2335.)

(This Order will be reprinted for posting on Notice Boards.)

178.

NAVAL, MILITARY AND AIR FORCE CLUB, ADELAIDE.

The Naval, Military and Air Force Club, Grenfell-street, Adelaide, is available for use by all officers of the Allied Forces in transit to and from Adelaide from 1000 to 2300 daily, except Sundays, when the club will be closed.

2. Amenities available are showers, squash, billiards, periodicals, card games, writing facilities, light meals and beverages.

3. Navy Order 578 of 1943 is cancelled.

(462/201/2337.)

Dept. of Army

RESTRICTED.

(FOR OFFICIAL USE ONLY.)

Commonwealth Navy Orders.

Navy Office, Melbourne,
8th May, 1945.

The following Orders, having been approved, are hereby promulgated for information and guidance and necessary action.

By direction of the Naval Board,

J. O. Spacandee
Secretary.

*The Commodore Commanding H.M.A. Squadron,
and Commanding Officers of H.M.A. Ships,
Officers in Charge of H.M.A. Naval
Establishments, and others concerned.*

TABLE OF CONTENTS.

No.	Subject.
179.	National Security Regulations—Delegation of Powers and Order Made Thereunder.
180.	Supply Officer, 7th Destroyer Flotilla.
181.	Post-war Employment—Disclosure of Top Secret, Secret or Confidential Information about Equipment, &c., to Civilian Firms.
182.	Examination for the Rank of Lieutenant-Commander (S), R.A.N.
183.	Wound Stripes.
184.	Publicity—Assistance for War Correspondents.
185.	Victualling Store Issuing Ship "Merkur"—Responsibility as Between the Master and the Deputy Victualling Store Officer in Relation to Stores Maintained for Issue.
186.	Naval Stores Returned to Bases from H.M.A. Ships and Services—Disposal.
187.	Boiler Water—Hydrometers, Sensitive, Glass—Pattern 37A.
188.	Cartridges S.A. .455-in. Ball, Revolver, Mark II—Withdrawal.
189.	H.M.A. M.Ls.—Q.F. 40 mm. Bofors Ready Use Ammunition.
190.	Books and Forms.

179.

DELEGATION OF POWERS AND ORDER MADE UNDER NATIONAL SECURITY REGULATIONS.

The following are promulgated for information:—

(*Commonwealth Gazette*, No. 84, dated 26th April, 1945.)

National Security Act 1939-1943.

(a) DELEGATION OF POWERS BY MINISTER.

Whereas by section 17 of the *National Security Act 1939-1943* it is provided that any Minister of State may in relation to any matters or class of matters, or in relation to any particular State or part of Australia, by writing under his hand, delegate all or any of his powers and functions under the Regulations (except this power of delegation) so that the delegated powers or functions may be exercised by the delegate with respect to the matters or class of matters, or the State or part of Australia, specified in the instrument of delegation:

Now therefore I, Donald Cameron, the Postmaster-General, for and on behalf of the Minister of State for the Army, do hereby delegate to every officer who shall at any time during the continuance of this delegation be holding the office or performing the duties of the office of Chief of the Naval Staff, the powers and functions conferred upon the Minister by Regulations 54 and 55 of the National Security (General) Regulations insofar as the exercise of such powers and functions is necessary for Naval purposes.

Dated this thirteenth day of April, 1945.

D. CAMERON, Postmaster-General,
for and on behalf of the Minister
of State for the Army.

(*Commonwealth Gazette*, No. 84, dated 26th April, 1945.)

Commonwealth of Australia.

NATIONAL SECURITY (GENERAL) REGULATIONS.

(b) ORDER UNDER REGULATION 55.

Whereas by Regulation 55 of the National Security (General) Regulations, it is provided that the Minister of State for the Army may by order authorize, subject to any restrictions and conditions imposed by the order, the use of any land specified therein for naval, military, or air force purposes, during the period specified in the order; and any such order may, so far as appears to that Minister to be necessary or expedient for the purposes thereof, provide—

- (a) for entitling persons using any land in pursuance of the order to do such acts in relation to the land as are specified in the order; and
- (b) for prohibiting or restricting the exercise of rights of way over that land, and of other rights relating thereto, which are enjoyed by any person, whether by virtue of an interest in that land or otherwise:

And whereas by Instrument of Delegation dated the thirteenth day of April, 1945, made in pursuance of section 17 of the *National Security Act 1939-1943*, the Postmaster-General for and on behalf of the Minister of State for the Army delegated to me the powers conferred on the Minister by Regulation 55 of the National Security (General) Regulations:

Now therefore I, Guy Charles Cecil Royle, acting in pursuance of the said Regulation and Instrument of Delegation do hereby order as follows:—

1. I hereby authorize the use of the land described in the Schedule to this Order as a bombardment range for practice firings by warships, during the period commencing on the thirtieth day of April, 1945, and ending on the day on which this Order shall be withdrawn.
2. During the period specified in the preceding paragraph, no person shall enter or be on the said land.

SCHEDULE.

All that area of land (including land covered with water) in and adjacent to Jervis Bay, in the State of New South Wales, situated between 150 deg. 48 min. 10 sec. and 150 deg. 52 min. 04 sec. E. Long., and 35 deg. 01 min. 48 sec. and 35 deg. 04 min. 12 sec. S. Lat.

Dated this thirteenth day of April, 1945.

GUY ROYLE,
Chief of the Naval Staff.

180.

SUPPLY OFFICER, 7TH DESTROYER FLOTILLA.

The Supply Officer, 7th Destroyer Flotilla, is now located in H.M.A.S. *Kuttabul*.

2. Correspondence and signals should be addressed accordingly.
3. Navy Order 512 of 1944 is cancelled.

(443/201/1463.)

181.

POST-WAR EMPLOYMENT—DISCLOSURE OF TOP SECRET, SECRET OR CONFIDENTIAL INFORMATION ABOUT EQUIPMENT, ETC., TO CIVILIAN FIRMS.

A.F.O. 6687/1944—Post-War Employment—Disclosure of Top Secret, Secret or Confidential Information about Equipment, &c., to Civilian Firms—is reprinted hereunder. The principles set out therein are to be observed by personnel of the Royal Australian Navy.

2. Australian personnel are, however, subject to the restrictions imposed by the *Crimes Act 1914-1941* and not to the *Official Secrets Acts 1911-1939*.

3. In regard to paragraph 3 of the A.F.O., cases of exceptional difficulty should be referred to the Naval Board for instructions.

"Their Lordships' attention has recently been drawn to the fact that certain civilian firms, in considering the post-war employment of such of their personnel as are at present serving in H.M. Forces, have sent out a form of questionnaire in which these personnel are requested to give details of the type of work on which they have been engaged during their period of service in H.M. Forces. Before answering questions of this nature, it is important that personnel should remember their obligations with regard to the disclosure of information acquired by them during their period of service in H.M. Forces.

2. All officers and ratings, including members of the W.R.N.S., who in the course of their duties have had access to Top Secret, Secret or Confidential equipment of any kind whatsoever, whether during the development, manufacture, trial or completed stage, are reminded that they are bound by the *Official Secrets Acts 1911-1939*, and that information concerning such equipment which they may have acquired during their service in the Navy or to which they may have had access as a result of that service, must not be published or communicated either directly or indirectly to another person in any form, except in the course of official duties. It is also pointed out that Naval personnel are subject to the restrictions imposed by the Official Secrets Acts both while serving *and after they have left* the Service, and that any infringement of these Acts renders them liable to serious penalties.

3. Personnel are therefore warned that they should exercise great discretion in filling in any questionnaires such as are referred to in paragraph 1 of this Order. In cases where there is any doubt whether information which it is desired to give is permissible, the advice of their Commanding Officer should be sought, who will if necessary refer the matter to the appropriate superior authority. In cases of exceptional difficulty, the matter should be referred to the Admiralty for instructions."

(835/201/87.)

(This Order will be reprinted for posting on Notice Boards.)

182.

EXAMINATION FOR THE RANK OF LIEUTENANT-COMMANDER (S), R.A.N.

An examination for the rank of Lieutenant-Commander (S) will be held during 1945. The provisions of Admiralty Fleet Order 2704/1944 are applicable, *vide* Navy Order 648 of 1944.

2. Part I of the examination will be held about September, 1945, and Part II six months later.

3. Officers who are eligible and desire to sit should forward their applications to Navy Office by 1st July, 1945, indicating whether they wish to take Part I or Part II.

4. The section relating to air stores will be omitted from Paper C.

5. Navy Order 102 of 1945 is hereby cancelled.

(565/206/264.)

183.

WOUND STRIPES.

With reference to Navy Order 48 of 1945, it has been approved that disabilities attributable to exposure at sea in open boats, directly due to enemy action (for instance, after a vessel has been lost by enemy action), shall be regarded as a qualification for the grant of a wound stripe, provided that the usual requirements relative to the period of hospital or equivalent treatment are satisfied.

(416/201/1072.)

(This Order will be reprinted for posting on Notice Boards.)

184.

PUBLICITY—ASSISTANCE FOR WAR CORRESPONDENTS.

To assist in obtaining publicity of a desirable type for the work of the Royal Australian Navy, the Commanding Officer of each H.M.A. Cruiser, L.S. (I), Destroyer and Frigate, is to detail an officer whose special duty it will be (in addition to his normal duties)—

- (a) to extend guidance and assistance to any War Correspondents and/or Photographers who may be authorized to visit the ship;
- (b) to assist, if necessary, in arranging despatch of their stories or photographs to the nearest censorship authority for release; and
- (c) to furnish to the Director of Naval Intelligence, Navy Office, Melbourne, or to the nearest officer of the R.A.N. Naval Information Section, any material of Naval publicity interest which may arise.

2. Similarly, an officer is to be detailed in each H.M.A. Naval Shore Establishment where no Staff Officer (Intelligence), or Naval Intelligence Officer is borne; but, where an officer is appointed for intelligence duties, the duties set out in paragraph 1 above are to be allocated to him.

3. The names of the officers selected for these duties are to be reported to the Naval Board as soon as possible.

4. Material—particularly notes regarding censorship procedure—for the guidance of the officers concerned will be forwarded from the Naval Board.

(564/201/453.)

185.

VICTUALLING STORE ISSUING SHIP "MERKUR"—RESPONSIBILITY AS BETWEEN THE MASTER AND THE DEPUTY VICTUALLING STORE OFFICER IN RELATION TO STORES MAINTAINED FOR ISSUE.

The Deputy Victualling Store Officer in the Victualling Store Issuing Ship *Merkur* is responsible for the safe custody and preservation of all naval and victualling stores maintained on board for issue to H.M.A. Ships and other approved services, also for all arrangements in connexion with the procurement of such stores and their receipt and issue, or other disposal, in accordance with standing instructions issued by the Director of Victualling.

2. The master is responsible for all matters relating to the navigation and safety of the ship, for the safe and proper stowage of the cargo, and for the control of the crew and any D.E.M.S. ratings on board. He is also responsible for maintaining in efficient working condition all cargo handling gear and appliances, for the loading and discharge of stores as may be required by the Deputy Victualling Store Officer and for all work incidental thereto, such as handling of beams and hatches, size and make up of cargo slings, &c.

3. Signals and other correspondence for *Merkur* should be addressed as follows:—

Deputy Victualling Store Officer—

All matters in connexion with Service stores maintained for issue, the Naval supply staff borne, and general questions concerning the employment of the ship in so far as they affect storing and supply arrangements. The Deputy Victualling Store Officer will keep the master fully informed, as necessary, concerning such matters.

Master—

All matters concerning the sailing, navigation and safety of the ship; responsibility for the ship's crew and D.E.M.S. ratings, and for the care and maintenance of ship's stores. The master will keep the Deputy Victualling Store Officer fully informed of the ship's projected movements.

(2026/10/1704.)

186.

NAVAL STORES RETURNED TO BASES FROM H.M.A. SHIPS AND SERVICES—DISPOSAL.

Naval stores returned from H.M.A. ships and services to the under-mentioned bases are in future to be surveyed as necessary and disposed of at the base concerned, except in cases where economical repair can only be effected at Sydney or, where it is desirable, having regard to the nature of the item, for disposal to be effected at the latter port:—

Darwin.
Thursday Island.
Port Adelaide.
Townsville.
Madang.
Milne Bay.
Port Moresby.

2. The following procedure is to be observed:—

- (a) Applications for survey should be made in the usual manner on forms A.S. 331 which should be forwarded to the Supply Officer (Naval Stores), at the base naval store, accompanied by a demand on Form A.S. 134D for items required in lieu, a reference to the serial number of the A.S. 331 being quoted on the demand voucher.
- (b) A receipt should be furnished by the Supply Officer (Naval Stores), on the triplicate copy of the Form A.S. 331 for the items returned to the base naval store.
- (c) The stores should be surveyed by a board of officers, comprising the Supply Officer (Naval Stores), and the Technical Officer, i.e., Engineer Officer, Shipwright Officer, &c.,

of the base, who should furnish their recommendations as to the disposal on the original and duplicate copies of the survey voucher, Form A.S. 331. The recommendations of the surveying officers are to be approved by the Naval Officer-in-Charge before action to implement such recommendations is taken.

(d) The approved disposal of stores will generally come under one of the following categories and the action to be taken in respect of each is as follows:—

(i) *Stores to be repaired locally.*—Such items are to be taken on charge in the base naval store account for serviceable naval stores and also in the account of repairable stores direct from the duplicate copy of the survey voucher A.S. 331. When issued for repair, a receipt is to be obtained from the Head of the Department concerned on Form A.S. 549, and on return to the naval store after repair, a receipt is to be furnished on another Form A.S. 549, the relevant columns of the account of repairable stores being completed as requisite.

A pro forma of the account of repairable stores which should be kept by the Supply Officer (Naval Stores), is appended.

In this connexion, it will be observed that on receipt of repairable stores, the items will be entered in the serviceable stores ledger, and until the item has been again made serviceable it will be necessary to refer to the account of repairable stores to ascertain whether any of the serviceable stores stock is out for repair. When the item has been received from repair, the appropriate columns of the account of repairable stores should be completed, but no entry in the serviceable stores ledger will be necessary, the item having been entered therein when received in a repairable condition.

(ii) *Return to Superintending Naval Store Officer, Sydney.*—Such items should be taken on charge from the report of survey, Form A.S. 331, in a special ledger on Forms A.S. 151. The items should be returned to the Superintending Naval Store Officer, Sydney, for survey, an application for survey being raised as necessary by the Supply Officer (Naval Stores), and the special ledger credited in due course from the receipted (triplicate) copy of the survey voucher Form A.S. 331.

(iii) *Not Repairable—Bring to Arisings.*—Such items are to be brought to arisings in cases where the latter can be utilized and the appropriate certificates as to arising: produced, i.e., copper old, steel old, &c., completed by the Supply Officer (Naval Stores), on the reverse side of the original and duplicate copies of Form A.S. 331. The arisings are to be taken on charge in an arisings ledger direct from the duplicate copy of the survey voucher, Form A.S. 331.

(iv) *Not Repairable—No further Service Use, &c.*—In such cases, the items should be transferred to the Army Salvage Organization. A receipt should be obtained from

the Army representative on Form A.S. 549, one copy of which should be attached to the original and duplicate copies of the survey voucher A.S. 331. The registered number of the A.S. 549 should be inserted on the Form A.S. 331 and a cross reference also made on the Forms A.S. 549.

(v) *Useless, no value, and not acceptable to the Army Salvage Organization.*—Such items are to be destroyed in the presence of a responsible officer who is to complete and sign the certificate of destruction on the back of the original and duplicate copies of the survey voucher Form A.S. 331. In all cases where destruction of naval stores has been approved, the local auditor is to be informed, by memorandum, of the items to be destroyed, at least seven days before the date on which it is proposed to destroy the stores, in order that his representative may witness the destruction if desired.

(vi) Items surveyed under categories (d)—(iii), (iv) and (v) above, should be carefully reviewed before approval to the recommendations of the board of survey is given on Forms A.S. 331 and covering Naval Board approval is to be obtained in respect of the disposal of these items.

NOTE.—Some use for practically all unserviceable items irrespective of condition can be found by the salvage organization and, before an item is destroyed, it should be established that it is not acceptable to the salvage depot. As a general rule, destruction should be limited to items in respect of which such disposal is essential, e.g., where immediate action is necessary to avoid fire risk, infected articles, &c.

(e) Duplicate copies of Forms A.S.331 and vouchers A.S. 549 for the above-mentioned transactions should be bundled in the usual manner as supporting vouchers to the base naval store accounts. The original Forms A.S. 331, together with copies of Forms A.S. 549 as appropriate should be forwarded to the Director of Naval Stores monthly under cover of Return A.D. 74/74A.

ACCOUNT OF REPAIRABLE STORES.

Received in Repairable Condition.					Issued in a Repairable Condition.		Issued for Repair.		Returned After Repair.	
Receipt Voucher and Bundle Date.	Pattern No.	Description.	Denomination.	Qty.	Voucher No. and Bundle Date.	Qty.	Voucher No. and Bundle Date.	Qty.	Voucher No. and Bundle Date.	Qty.

(612/242/1780.)

187.

BOILER WATER—HYDROMETER, SENSITIVE, GLASS—PATTERN 37A.

Supplies of hydrometers, sensitive, glass, pattern 37A, have recently been received from overseas graduated from S.G. 1,000 to S.G. 1,005 with twenty intermediate divisions, and some confusion has been caused thereby.

2. In these hydrometers, the S.G. 1,000 mark corresponds with the usual 0° graduation at 100°F. and S.G. 1,005 with the customary 2° density mark. Each of the twenty divisions on the hydrometer marked in terms of specific gravity corresponds with the tenths of a degree marks on the usual type of instrument.

3. Engineer Officers are to ensure that Engine Room personnel understand that boiler water densities can be read directly in tenths of a degree from either instrument.

4. In connexion with boiler water densities, it is important that they should always be taken with the water at a temperature of 100°F. and correctly reported. The careless use of the words "one" or "two," &c., when "point one" or "point two" is intended leads to misunderstanding and confusion as to the actual meaning of hydrometer readings.

(670/201/947.)

188.

CARTRIDGES S.A. .455-IN. BALL, REVOLVER, MARK II— WITHDRAWAL.

Cartridges .455-in. ball, revolver, Mark II, are to be withdrawn from Naval Service.

2. Stocks of Mark II cartridges held for practice purposes are to be returned to the nearest Naval Armament Depot and Mark VI or VIZ ammunition demanded in lieu.

3. Naval Armament Depots are to dispose of stocks in accordance with Admiralty Fleet Order 6280/44.

4. Navy Order 181 of 1943 is hereby cancelled.

(408/206/1540.)

189.

H.M.A. M.L's—Q.F. 40 mm. BOFORS READY USE AMMUNITION.

As further topweight is not permissible, ready use ammunition for 40 mm. Bofors guns in H.M.A. M.L's is to be limited to 72 rounds contained in three pattern 7100 ready use lockers as shown in the appended diagram.

2. Vessels concerned are to raise a defect list item accordingly.

(603/246/4557.)

FAIRMILE PATROL BOAT.
FITTING OF 40 MM. BOFORS FWD

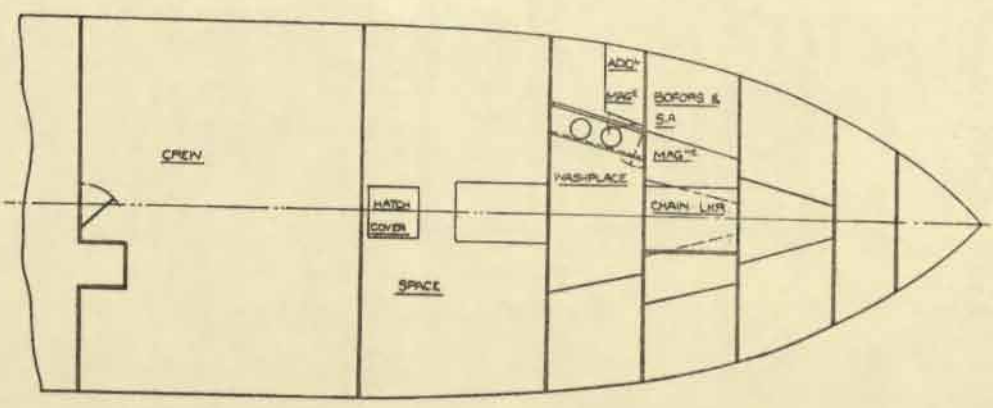
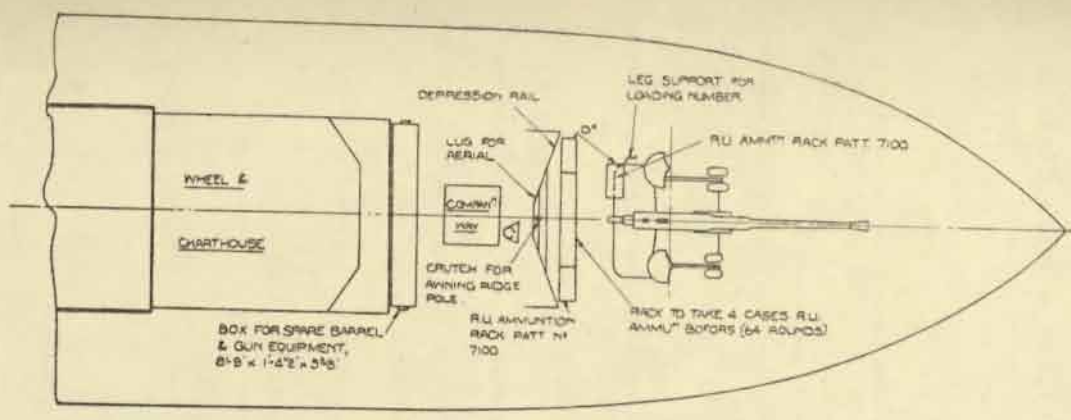
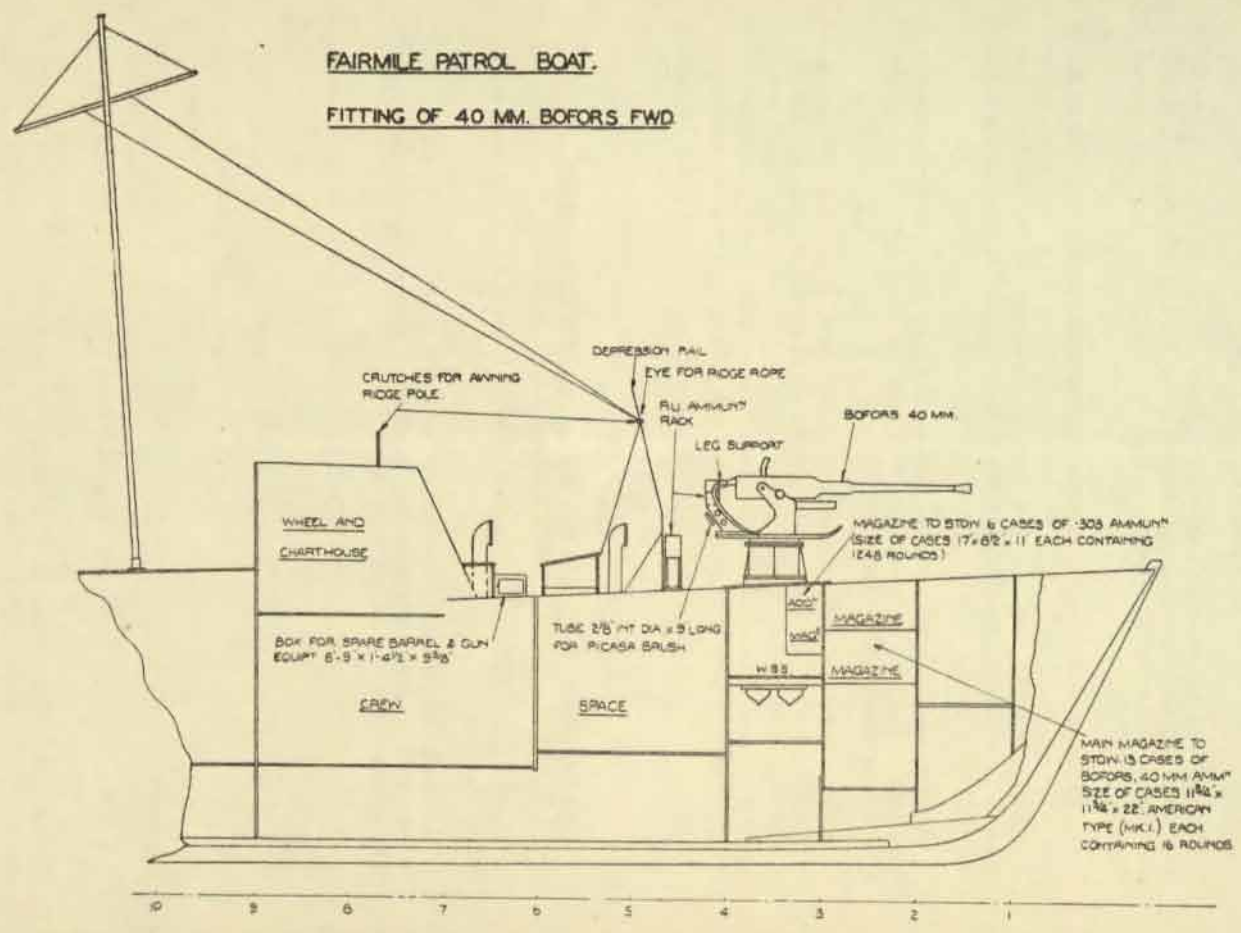

190.

BOOKS AND FORMS.

The latest Admiralty revisions of the under-mentioned forms have been adopted for use in the R.A.N. Supplies will be effected, on demand, by the Superintending Naval Store Officer, Sydney, when stocks of the existing forms are exhausted:—

S.1404 (outside) (March, 1944) Return of B.L. and Q.F. Guns (Annual).

S.1404 (inside) (September, 1943) Return of B.L. and Q.F. Guns (Annual).

(480/202/4696.)

2. The under-mentioned form has been introduced for use in the R.A.N. in lieu of the corresponding Admiralty Form S.1235. Supply will be effected, on demand, by the Superintending Naval Store Officer, Sydney, when stock of the existing form is exhausted:—

A.S. 1235.—Certificate—Engine Room Training of Officers Specializing in Engineering.

(480/202/4703.)

3. The under-mentioned form has been revised. Supply will be effected, on demand, by the Superintending Naval Store Officer, Sydney, when stock of the existing form is exhausted:—

A.S. 325A.—W/T Operator's Log.

(480/202/4693.)

4. The under-mentioned form has been revised. Supply will be effected, without demand, by the Superintending Naval Store Officer, Sydney. On receipt of the revised form, the existing form is to be regarded as obsolete:—

N.A.2.—Salaries.

(480/201/3178.)

5. The stock of the under-mentioned form will be held at Garden Island in future instead of Navy Office as previously:—

T.406.—Receipt for Extra Payments or for overtime.

6. Navy Order 372 of 1943 is cancelled.

(480/201/3516.)

By Authority: H. E. DAW, Government Printer, Melbourne.

RESTRICTED.(FOR OFFICIAL USE ONLY.)

Commonwealth Navy Orders.

Navy Office, Melbourne,

15th May, 1945.

The following Orders, having been approved, are hereby promulgated for information and guidance and necessary action.

By direction of the Naval Board,

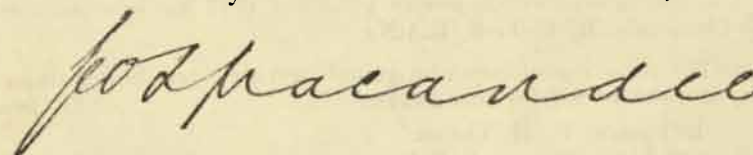

Secretary.

*The Commodore Commanding H.M.A. Squadron,
and Commanding Officers of H.M.A. Ships,
Officers in Charge of H.M.A. Naval
Establishments, and others concerned.*

TABLE OF CONTENTS.

No.	Subject.
191.	Port Moresby—Reduction to Port Director Status.
192.	Ian Macdonald Memorial Prize.
193.	Machinery Spares—Spare Propellers and Shafts for M.L's Type B, H.D.M.L's and Air Sea Rescue Boats—Authorized Establishment.
194.	Cartridges S.A. .455-in. Ball Revolver—Lot M.Q. 23/12/42—Withdrawal.
195.	Return of Receipted "Extra" Copies of Bills of Lading and Consignment Notes.
196.	Binoculars—Precautions Regarding Security before Use.
197.	Radar Control and Radar Plot Scheme—Policy.
198.	Canteen Stores for H.M.A. Ships.
199.	Extra Issues—Fruit and Tomato Juices.
200.	Temporary Commissions in the Special Branch R.A.N.V.R.—Selection of Ratings from the Lower Deck.
201.	Corrigendum.

C.4568/45.

191.

PORT MORESBY—REDUCTION TO PORT DIRECTOR STATUS.

Port Moresby has been reduced to the status of a Port Directorate from 1st May, 1945. The functions of Port Moresby will be those of Port Directorate with fuelling facilities available, and minor repairs base in state of preservation.

2. Port Moresby will be under the Naval Officer-in-Charge, Townsville, for operational and administrative control, accounts being carried in H.M.A.S. *Magnetic*.

3. Port Moresby ceases to be a Defended Port and A.C.B. 0248 is to be amended accordingly.

4. The title Naval Officer-in-Charge, Port Moresby, is to be retained.

(1867/2/126.)

192.

IAN MACDONALD MEMORIAL PRIZE.

The Ian Macdonald Memorial Prize for 1944 has been awarded to Sub-Lieutenant R. E. Lesh, R.A.N.

2. The following officers who gained first-class certificates in signals were also considered for this award:—

Lieutenant B. H. Loxton,
Sub-Lieutenant A. J. Robertson,
Sub-Lieutenant J. Gunn,
Sub-Lieutenant H. B. Gerrett,
Sub-Lieutenant P. H. Doyle,
Sub-Lieutenant K. W. Shands.

(635/201/1554.)

193.

MACHINERY SPARES—SPARE PROPELLERS AND SHAFTS FOR M.L.'s TYPE B, H.D.M.L.'s AND AIR SEA RESCUE BOATS—AUTHORIZED ESTABLISHMENT.

In view of the high usage rate of propellers and shafts fitted in Motor Launches Type B, 80-ft. H.D.M.L.'s, 72-ft. H.D.M.L.'s, and Air Sea Rescue boats, scales and allowances for these craft have been reviewed and now approved in accordance with the following establishments:—

2. *List A Spares*.—Establishment List for on board spares propellers and shafts supplied for each craft.

Type of Craft.	Propellers.	Shafts.
Motor Launches—Type B. ..	2 No.	1 No.
80 ft. H.D.M.L.'s. ..	2 No.	1 No.
72 ft. H.D.M.L.'s. (Ex. U.S.A.) ..	2 No.	1 No.
72 ft. H.D.M.L.'s. (Ex. U.K.) ..	4 No.	2 No.
63 ft. Air Sea Rescue Boats ..	2 No.	1 No.

3. *List B Spares*.—Establishment List for spare propellers and shafts at top overhaul bases and mobile bases.

Name of Base.	M.L. Type B.		80 ft. H.D.M.L.		72 ft. H.D.M.L. U.S.A.		63 ft. Air Sea Rescue Boat.	
	Propellers.	Shafts.	Propellers.	Shafts.	Propellers.	Shafts.	Propellers.	Shafts.
Fremantle ..	2	1
Darwin ..	2	1	2	1	2	1	2	1
Thursday Island ..	2	1	2	1	2	1	1	1
Port Moresby ..	2	1
New Guinea— Alexishafen ..	8	4	3	12	6
Cairns ..	2	1
Townsville ..	2	1	2	1	2	1	2	1
Whangpu ..	2	1	2	1	2	1	2	1
Platypus ..	2	1	2	1	2	1	2	1

4. *List C*.—Establishment List for spare propellers and shafts at major overhaul bases.

Name of Base.	M.L. Type B.		80 ft. H.D.M.L.		72 ft. H.D.M.L. U.S.A.		63 ft. Air Sea Rescue Boat.	
	Propellers.	Shafts.	Propellers.	Shafts.	Propellers.	Shafts.	Propellers.	Shafts.
Brisbane (Colmslie)	6	3	4	2	6	3	6	3
Sydney (To be held at Central M.S. Depot) ..	6	3	4	2	6	3	6	3

5. *Procedure for Supply*.

(a) Demands for supply from both bases and craft are to be forwarded on form MS/DE(N) 17 to the Central Machinery Spares Depot, Sydney, and supply will be forwarded as equipment comes forward.

(b) In the event of immediate supply not being available, the demanding authority will be informed accordingly and the requisition held over until supply can be made and forwarded without further requisition.

(c) Additional requisitions are only to be forwarded to the Central Machinery Spares Depot for replacements to meet loss due to usage, damage, &c.

6. *Craft Engaged on Detached Service*.

(a) Certain craft have been allocated for special detached service and with the Officer-in-Charge, Hydrographic Branch, and approval has been given for these craft to carry double the approved allowances. 'On board' spares are 4 No. propellers 2 No. shafts.

(b) These craft are to raise requisition form MS/DE(N) 17 for the supply of the additional propellers and shaft for 'on board' spares quoting this Navy Order as authority.

(c) Craft may land the excess quantity of 'on board' spares at their immediate operational base, but, when transferred elsewhere, all spares are to be transferred with the boat.

(d) When craft are returned to normal operational service, all spares in excess of the authorized list, as in paragraph 2 above, are to be landed, taken on charge as base spare stock and the Central Machinery Spares Depot, Sydney, notified accordingly.

7. *Return of Salvaged Equipment.*

(a) Arrangements are to be made to return to the Central Machinery Spares Depot, Sydney, all equipment removed from craft which has been replaced with new stock.

(b) Upon return to the Central Machinery Spares Depot, all returned equipment is to be surveyed, and, if considered serviceable, repairable or capable of reclamation, is to be repaired, reconditioned or modified as required for other services. All equipment received and surveyed as 'too costly for repair' may be disposed of as salvage material only.

8. *Stock Spares.*

Provision has been made to provide for stock spares of propellers and shafts to cover replacements and the ordering cycle. Stock spares will be carried at the Central Machinery Spares Depot, Sydney, only.

(656/201/358.)

194.

**CARTRIDGES S.A. .455-in. BALL REVOLVER—LOT M.Q. 23/12 42—
WITHDRAWAL.**

Owing to an excessive number of missfires, cartridges S.A. .455-in. Ball Revolver, Lot M.Q. 23/12/42, are to be withdrawn from the Service.

2. H.M.A. ships are to demand replacements, on receipt of which the restricted cartridges are to be dumped in deep water. The quantity so disposed of is to be reported to the Director of Ordnance, Torpedoes and Mines, Navy Office, by memorandum, quoting this Navy Order.

3. Stocks of restricted cartridge in naval armament depots and bases are to be destroyed, either by burning or dumping in deep water, as convenient, and included in a covering report of survey.

(412/204/237.)

195.

**RETURN OF RECEIPTED "EXTRA" COPIES OF BILLS OF LADING
AND CONSIGNMENT NOTES.**

With reference to C.O.R., Article 534, it has been brought under notice that in a number of instances the receipted copy of the consignment note (Form A.D. 80) and "extra" copy of the bill of lading (Form A.D. 79) in respect of naval stores forwarded by rail, sea, &c., have not been returned by the consignee to the consignor.

2. Action should be taken by all concerned to ensure that bills of lading and consignment notes are receipted or otherwise endorsed, as applicable, and returned promptly to the consignor.

(453/206/727.)

196.

**BINOCULARS—PRECAUTIONS REGARDING SECURITY BEFORE
USE.**

Losses of binoculars have occurred on several occasions recently owing to the precautions laid down in A.F.O. 1044/42 in regard to the use of securing straps and lanyards not being observed.

2. The attention of all concerned is drawn to the necessity for compliance with this Order, which states as follows:—

"Investigation into recent losses of binoculars has revealed that in several instances codline lanyards have not been attached in accordance with B.R. 224, paragraph 480. Attention is therefore drawn to the instructions and to the necessity for ensuring that the securing straps of all binoculars are serviceable before use.

2. Administrative authorities are to take special steps to ensure that all concerned, especially the Commanding Officers of small vessels who may not usually see Admiralty Fleet Orders, are aware of these instructions."

(670/201/849.)

197.

RADAR CONTROL AND RADAR PLOT SCHEME—POLICY.

With reference to Navy Order 155 of 1945, paragraph 2 is to be amended as follows:—

Note (i).—For "In the case of R.C.3(P)" read "In the case of R.C.3(P) or R.P.3(P)".

Note (ii) (b).—For "as leading seaman (Radar) if anticipated date is after 15th May, 1944." read "as leading seaman (Radar) if ante-dated after 15th May, 1944."

(348/218/1.)

198.

CANTEEN STORES FOR H.M.A. SHIPS.

It is notified that no liability is accepted by the Department of the Navy in respect of any loss or damage in transit of canteen stores consigned by merchants to H.M.A. ships or establishments through victualling store officers in accordance with Navy Order 153 of 1943.

2. Ships or establishments which have canteen stores forwarded to them in this manner by merchants are advised to arrange with the suppliers to insure the goods on their behalf against ordinary marine or other risk whilst in transit, as well as against war risks, if such precautions are desired.

(612/250/205.)

199.

EXTRA ISSUES—FRUIT AND TOMATO JUICES.

With reference to C.O.R. Articles 423 and 424 concerning extra issues of provisions in H.M.A. Ships and Naval Establishments, approval is given to a daily issue of fruit juice or tomato juice, as provided in paragraphs 3 and 4 below, when Naval personnel are serving on shore or afloat North of 20 degrees South latitude.

2. These juices are to be issued in addition to the ordinary lime juice ration, which it is intended shall be continued as a general daily issue in the tropics as hitherto, the time of issue of the additional daily beverage being so arranged as not to conflict with the normal lime juice issue.

3. The approved daily issue of these juices is to be one of the following:—

Juice.	Daily Ration.	Remarks.
(a) Orange Juice ..	1/5 pint (4 fluid oz.) ..	Issue neat if desired.
(b) Tomato Juice ..	1/5 pint (4 fluid oz.) ..	Issue neat if desired.
(c) Orange and Grape-fruit Juice	1/5 pint (4 fluid oz.) ..	Add two parts of water to one of juice before issue, also sugar as necessary.
(d) Pineapple Juice ..	1/5 pint (4 fluid oz.) ..	Add at least equal quantity of water before issue.
(e) Lemon Juice ..	1/10 pint (2 fluid oz.)	Add four parts of water before issue, also sugar as necessary.

The remarks column in the foregoing scale has been inserted for general guidance as to the method of issue, and may be departed from as desired.

4. Stocks of these juices are to be maintained in approximately equal quantities to enable the daily issue of each juice to be made in rotation, it being intended that for reasons of health all personnel should regularly partake of the approved daily issue in order to reduce, as far as is practicable, the deficiency of vitamin C content in the current daily diet in advanced areas under existing conditions.

5. Stocks of orange and grapefruit juice are not yet available at Royal Edward Victualling Yard, Sydney, and the several Victualling Depots. When supplies are received in due course, this juice will be substituted, on exhaustion of present stocks, for pineapple juice owing to the latter's low vitamin C content. Pending the issue of a further Navy Order on the subject, orange and grapefruit juice should not, therefore, be demanded.

6. Navy Order 672 of 1943 is cancelled.

(1919/2/67.)

(This Order will be reprinted for posting on Notice Boards.)

200.

TEMPORARY COMMISSIONS IN THE SPECIAL BRANCH R.A.N.V.R.— SELECTION OF RATINGS FROM THE LOWER DECK.

The Naval Board have decided that Royal Australian Naval Reserve and Royal Australian Naval Volunteer Reserve ratings and those ratings entered since the commencement of hostilities under "hostilities only" engagements, of all branches, may be considered for promotion to commissioned ranks in the Special Branch, Royal Australian Naval Volunteer Reserve.

2. Officers of the Special Branch may be employed on the following duties:—

Executive—Special.
Operations.
Intelligence.
Armament Store Accounting.
Sea Transport.
Naval Control Service.
Rail Transport.
Mercantile Movements.
A/S Fixed Defences.
Controlled Mining.
R.M.S. and B.S.
C.B's.
D.E.M.S. (Gunnery duties).
Boom Defence Service.
Radar.
Meteorological.

Other categories may be added as the necessity arises. Cypher officers are excluded from the above, promotion for this purpose being open to coders only. *Vide* Navy Order 582 of 1943.

3. Forms C.W.1 should be commenced for ratings considered suitable for promotion to commissioned rank for any of the foregoing duties. On commencement of Forms C.W.1, Forms C.W.1A should immediately be prepared and copies of these forms forwarded to the Secretary, Naval Board, and to the Commodore Superintendent-of-Training, Flinders Naval Depot. The original Forms C.W.1 and C.W.1A should be retained, and should follow the rating concerned when drafted to a new ship or establishment.

4. *Medical Standard.*—Candidates must be free from any gross physical defect and must not suffer from any condition that is likely to become aggravated by duty, or render them incapable of carrying out their duties efficiently. Varicocele or varicose veins are not a cause of rejection unless very marked.

5. *Visual Standard.*—The visual standard is as laid down in A.F.O. 2474/43 with the following modification.

Colour vision below Grade III can be accepted in respect of candidates recommended for employment on the following duties:—

Executive duties on shore.
A/S Fixed Defences.
Controlled Mining.

Special Branch Officers for employment on the following duties must have colour vision of at least Grade III:—

Radar.
Meteorological.

6. *Executive—Special.*—The following are the conditions to be complied with by authorities when commencing Forms C.W.1 recommending ratings for this category of the Special Branch R.A.N.V.R.:—

- Ratings between the ages of 19½ years and 30 years will be eligible for consideration if below the medical standard required for the Executive Branch.
- Ratings of 30 years of age or over are eligible regardless of medical category.

When recommending ratings for this Branch, authorities should bear in mind that there is no shortage of officers for this type of executive duty on shore, and consequently this category will be reserved for those cases in which it is considered to be of advantage to the Service to promote a rating who would otherwise be ineligible for commissioned rank.

7. *Radar*.—Upon receipt by the Naval Board of duplicate copies of C.W. Forms, they will eventually be forwarded to the Commanding Officer, H.M.A.S. *Watson*, who will investigate the rating's technical qualifications. If satisfied that the rating concerned is technically qualified, the Commanding Officer, H.M.A.S. *Watson*, will then pass that information to the Commodore Superintendent-of-Training who, when vacancies occur, will arrange for the rating concerned to be drafted to Flinders Naval Depot to undergo a Special Branch course and for final decision as to whether selected to fill those vacancies existing for Radar Officers.

8. Ratings recommended for promotion in terms of this Order should have attained the minimum age of 19½ years, and, where vacancies exist, these ratings will be drafted to Flinders Naval Depot after preliminary selection by the Commodore Superintendent-of-Training, who will then arrange for a disciplinary course, together with any other course considered necessary, before final selection and promotion is effected.

9. Navy Order 9 of 1945 is cancelled.

(486/201/116.)

201.

CORRIGENDUM.

With reference to Navy Order 146 of 1945, "Honours and Awards to R.A.N. Personnel"—insert the heading "British Empire Medal" between "Mr. William Matthew Maughan, A/Warrant Ordnance Officer, R.A.N.", and "Chief Yeoman of Signals, Francis George Watkins, O.N. 14109".

(448/201/1507.)

By Authority: H. E. DAW, Government Printer, Melbourne.

RESTRICTED.

(FOR OFFICIAL USE ONLY.)

Commonwealth Navy Orders.

Navy Office, Melbourne,

22nd May, 1945.

The following Orders, having been approved, are hereby promulgated for information and guidance, and necessary action.

By direction of the Naval Board,

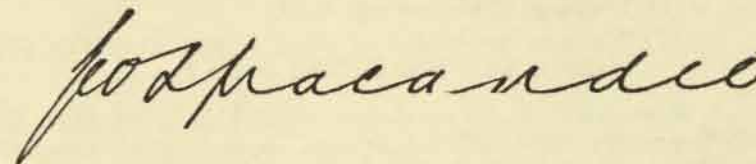

Secretary.

*The Commodore Commanding H.M.A. Squadron,
and Commanding Officers of H.M.A. Ships,
Officers in Charge of H.M.A. Naval
Establishments, and others concerned.*

TABLE OF CONTENTS.

No.	Subject.
202.	Cinema Branch—Adoption in the R.A.N.
203.	Bates of Treatment in Private Hospitals with Approved Accommodation for Naval Officers.
204.	Coastal Craft Section.
205.	Members of the Netherlands Forces Treated in R.A.N. Hospitals or Sick Quarters.
206.	Hall Scott Defender Engine Oil Cooler Cores.
207.	Modification of Tumbler Hook of Mark IV D.C. Throwers.
208.	Covers Breech Rifle No. 2.
209.	American 40 mm. Ammunition Clip Mark 3—Defects in Manufacture—Stoppages.
210.	Depth Charge Pistol Mark VII* Reg. No. 4614.
211.	Guns. Machine, Lewis .303-in.—Conversion of Mark IV A.A. Sights (100 knot) to Mark V (200 knot)—Fitting Mark III Butt Plates to Gun.
212.	Medical and Dental Stores—Supply of, in New Guinea Area.
213.	Supply of Officers' Uniforms, Including W.R.A.N.S. Officers and R.A.N. Nurses.
214.	Charge for Accommodation of R.N., Dominion and Allied Naval Personnel.
215.	Naval Censorship.

C.4820/45.

202.

CINEMA BRANCH—ADOPTION IN THE R.A.N.

A new branch to be known as the Cinema Branch is being introduced in the R.A.N. as a wartime measure. Ratings will be known as "cinema operator" (with the equivalent status of able seaman) and the usual higher ratings. Training will be arranged by the Naval Officer-in-Charge, Flinders Naval Depot.

2. *Duties and Employment.*—The cinema branch will embrace all types of work connected with instructional training films, e.g. :—

- (a) Operation of all cinema projectors including dome A.A. teachers, laying and training teachers, &c., also running repairs and routine maintenance.
- (b) General repairs and overhaul by specially trained maintenance parties under command of cinema maintenance officers.
- (c) Training of cinema operators.
- (d) Work on production of films, if and when this phase of cinema work is undertaken in the R.A.N.

3. *Recruitment and Transfer.*—As stated in Navy Circ. 645I of 8th September, 1944, selected ratings, on satisfactory completion of training course, will be transferred to cinema operator or the equivalent to their present ratings in that Branch. Ratings of all branches other than artificer, artisan and mechanic, with satisfactory ability and general good conduct will be eligible for transfer to the new branch. Transfers will be subject to manning requirements and will be effected only on the approval of the Naval Board. It is not intended at this stage to make provision for direct entry from shore in the cinema branch.

4. *Training and Advancement.*—Ratings selected for transfer to the cinema branch will undergo an initial course of thirteen weeks' duration at Flinders Naval Depot, on successful completion of which transfer will be effected as provided in paragraph 3 above.

Advancement to leading rates and above will be authorized by the Naval Officer-in-Charge, Flinders Naval Depot, and will be contingent on receipt of recommendation for advancement on Form A.S. 507, vacancies in fleet numbers and subject to compliance with the following conditions :—

(i) *To Leading Cinema Operator.*

- (a) Six months' service as cinema operator and/or wireman C/P.
- (b) Passed professionally for leading cinema operator after course of eleven weeks' duration at Flinders Naval Depot.
- (c) Conduct V.G. during preceding six months.
- (d) To be rated acting leading cinema operator. Confirmation as leading cinema operator will follow on completion of twelve months' satisfactory service.

(ii) *To Petty Officer Cinema Operator.*

- (a) Six months' service as leading cinema operator and/or leading wireman C/P including acting time.
- (b) Passed professionally for petty officer cinema operator after course of six weeks' duration at Flinders Naval Depot.
- (c) Conduct V.G. during preceding twelve months.
- (d) To be rated acting petty officer cinema operator. Confirmation as petty officer cinema operator will follow on completion of twelve months' satisfactory service.

(iii) *To Chief Petty Officer Cinema Operator.*

Subject to V.G. conduct during the preceding two years, petty officer cinema operators will be eligible for advancement to chief petty officer cinema operator to fill vacancies in fleet numbers.

NOTE.—The Naval Board reserves the right to approve of the accelerated advancement of ratings who qualify professionally for higher rating and who have obtained civilian qualifications and experience as cinema projectionists or in allied trades. Approval for such accelerated advancement will be given only on the special recommendation of the Naval Officer-in-Charge, Flinders Naval Depot, on the completion of the courses referred to at (i) (b) and (ii) (b) above, and subject to vacancies in fleet numbers.

5. *Pay—*

Rating.	Relative Rating.	Active Pay per Diem.
Cinema Branch—		s. d.
Cinema Operator	A.B.	9 0
After three years' man's time	A.B.	9 2
After six years' man's time	A.B.	9 6
Leading Cinema Operator	Ldg. Smn.	10 5
After three years' service as such	Ldg. Smn.	10 9
Petty Officer Cinema Operator	P.O.	11 11
After three years' service as such	P.O.	12 3
After six years' service as such	P.O.	12 7
Chief Petty Officer Cinema Operator	C.P.O.	13 3
After three years' service as such	C.P.O.	13 9
And thereafter triennial increments of 6d. per diem.		

6. *Uniform.*—Ratings in the cinema branch will wear the same uniform as seaman branch ratings and for the present the non-substantive badge of seaman torpedoman.

(349/22/2.)

(This Order will be reprinted for posting on Notice Boards.)

RATES OF TREATMENT IN PRIVATE HOSPITALS WITH APPROVED ACCOMMODATION FOR NAVAL OFFICERS.

The agreements made with Private Hospitals in the various capital cities have, with slight variations, been renewed until the 28th February, 1946.

2. Preference is to be given to the hospital with the lower rate of charge if accommodation is available and suitable for the case concerned.

3. Attention is directed to the provision of C.O.R., Article 548, clause (1), regarding class of accommodation allowed, and to clause (2) concerning preparation of vouchers for payment of claims.

4. Navy Order 305 of 1944 is hereby cancelled.

5. The rates of treatment for the year commencing 1st March, 1945, are shown hereunder:—

Name and Address of Hospital.	Private Room— (a) per Day. (b) per Week.	Two or more in Room— (a) per Day. (b) per Week.	Operating Theatre Charges— (a) Major. (b) Minor.	Charge for Special Nurses per Week.	Number of Beds Available.	Class of Case Taken.	Remarks.
<i>New South Wales—Sydney—</i> "Jenner," 2 Macleay-street, Potts Point. (Tel. FL 2113)	(a) 24s. (b) 168s.	Two or more in room— (a) 15s. (b) 105s.	(a) 42s. (b) 21s.	Day Nurse, 94s. 6d. and expenses plus board. Night Nurse, 116s. 6d. and expenses plus board	As beds are available.	Medical and Surgical only	
"St. Luke's" 18 Roslyn-street, Darlinghurst. (Tel. F 2181)	(a) 21s. to 30s. (b) 147s. to 210s.	Two in room— (a) 18s. (b) 126s. Three in room— (a) 15s. (b) 105s.	(a) 52s. 6d. (b) 31s. 6d.	Night and Day Nurse, 105s. plus board	Varying number available from time to time	Medical and Surgical only	
<i>Tasmania—Hobart—</i> "St. Helen's," 186 Macquarie-street. (Tel. 4109)	(a) 12s. (b) 84s.	(a) 9s. (b) 63s.	(a) 21s. (b) 10s. 6d.	Night and Day Nurse (including board), 105s. 1st week, 89s. subsequent weeks	16	All cases except infectious Public Health notification cases	Discount 5 per cent.—30 days
"Stowell," Stowell-avenue, Battery Point. (Tel. 4877 and 4878)	(a) 18s. to 25s. (b) 125s. to 175s., according to type of room available	(a) 14s. 6d. (b) 100s.	(a) 39s. 4d. (b) 15s. 6d.	Rate for special Nurses not contracted for because their fees are handled entirely by the Nurses' Club	36 Usually 5 to 10 beds available	Medical and Surgical only	Discount 5 per cent.
"St. John's," C. of E. (Incorporating Hobart Homeopathic Hospital, 10 Cascade-road. Tel. 5089)	(a) 21s. (b) 147s.	(a) 12s. (b) 83s.	(a) 42s. (b) 30s.	Day and Night Nurse (including board), 105s.	21	Medical and Surgical only	All rates less 10 per cent.
<i>Victoria—Geelong—</i> "Riviera," 80 Myers-street, (Tel. 1276)	(a) 16s. 6d. and 19s. 6d. (b) 115s. 6d. and 136s. 6d.	(a) 12s. (b) 84s.	(a) 42s. (b) 21s.	Day and Night Nurse (including board), 114s.	Several	Medical and Surgical only	
<i>Queensland—Brisbane—</i> "St. Helen's," Stanley-street, South Brisbane. (Tel. J 2213)	(a) 16s. 6d. to 21s. (b) 115s. 6d. to 147s. (according to type of room available)	Two in room— (a) 13s. 6d. (b) 94s. 6d. More than two— (a) 13s. (b) 90s.	(a) 42s. (b) 21s.	Night and Day Nurse 84s. plus 35s. for board, 3s. 6d. for laundry and fares	39	Medical and Surgical only. Infectious cases if approved by Health Dept.	10 per cent. discount allowed on maintenance and operation charges only
"Gregory," Gregory-terrace, Brisbane. (Tel. B 7371)	(a) 15s. to 21s. (b) 105s. to 147s. (according to type of room available)	(a) 13s. 6d. (b) 94s. 6d.	(a) 42s. (b) 21s.	Night and Day Nurse 21s. first day. Two days and over 84s. per week plus 5s. per day for board	18	Medical and Surgical only	
<i>South Australia—Adelaide—</i> "Memorial Inc.," Pennington-terrace, North Adelaide. (Tel. C 2302)	(a) 12s., 15s., 16s. 6d. or 18s. (b) 84s., 105s., 115s. 6d. or 126s., according to type of room available	Two in room— (a) 12s. (b) 84s. More than two— (a) 9s. (b) 63s.	(a) 42s. (b) 31s. 6d.	Night and Day Nurse (including board), 88s.	115	Medical and Surgical only	25 per cent. discount allowed on maintenance charges only for personnel with War Service
"Wolverton," 122 Esplanade, Semaphore. (Tel. Y 6423)	(a) 16s. 6d. (b) 115s. 6d.	(a) 13s. (b) 90s. Ward cases— (a) 11s. 6d. (b) 80s.	(a) 42s. (b) 21s.	Night and Day Nurse (including board), 85s.	20	Medical and Surgical only	
"Hutt Street," 121 Hutt-street, Adelaide. (Tel. C 4293)	(a) 13s. 6d. or 15s. (b) 90s. or 105s. (according to type of room available)	(a) 10s. (b) 70s.	(a) 42s. (b) 21s.	Night and Day Nurse (including board), 78s.	30	Medical and Surgical only	10 per cent. discount allowed for personnel with War Service
<i>Western Australia—</i> St. John of God, Subiaco	(a) 15s. to 18s. (b) 105s. to 126s. (according to type of room available)	(a) 12s. (b) 84s.	(a) 42s. (b) 21s.				Fees cover nursing charges, and include the usual drugs and dressings such as the supply and administering of morphia or barbitone but do not cover cases such as pneumonia, cardia, and amputations

With the exception of St. John of God charges, as indicated in the "Remarks" column, the cost of drugs, dressings, X-rays, &c., are extra.

204.

COASTAL CRAFT SECTION.

The under-mentioned amendments are to be made in the list of craft comprising the coastal craft section shown in Navy Order 652 of 1944:—

Add—

<i>Air Foam</i>	<i>Merak</i>	R.N.N. C.M.B. 26
<i>Air Guide</i>	M.F.V. 2046	R.N.N. C.M.B. 33
<i>Hawk</i>		

Delete—

<i>Air Host</i>	<i>Lorne</i>	<i>Tipton</i>
<i>Air Wave</i>	<i>Mako</i>	<i>Tropic Bird</i>
<i>Boonooroo</i>	<i>Marina</i>	<i>Vlaming</i>
<i>Ibis</i>	<i>Nilram</i>	<i>Zanana</i>
<i>Jurien</i>	<i>Sleuth</i>	
<i>Laurabada</i>	<i>Steady Hour</i>	

(1937/2/249.)

205.

MEMBERS OF THE NETHERLANDS FORCES TREATED IN R.A.N. HOSPITALS OR SICK QUARTERS.

In the case of personnel of the Netherlands Armed Forces treated in Royal Australian Naval Hospitals or Sick Quarters and fit for discharge, the following procedure is to be followed until further notice:—

- If the member is fit for discharge and fit to rejoin his ship or other post of duty, he is to be discharged thereto.
- If the member is fit for discharge but unfit to rejoin his ship or other post of duty, he is to be instructed to report to whichever of the following is relevant:—

In Victoria—

All personnel—to the Sick Bay, Royal Netherlands Naval Barracks, 364 Beaconsfield-parade, St. Kilda. (Tel. MX 1530.)

In Other States—

All personnel—to the Netherlands Naval or Army Liaison Officer.

2. Duplicate copies of the clinical reports marked "Confidential" are to be forwarded to the appropriate authorities—

In Victoria—

The Senior Naval Medical Officer,
R.N.N. Headquarters,
441 St. Kilda-road,
Melbourne, S.C.2. (Tel. LX 3753.)

The Director of Medical Services,
Netherlands East Indies Army,
431 St. Kilda-road,
Melbourne, S.C.2. (Tel. LA 1281.)

In Other States—

The Netherlands Naval or Army Liaison Officer.

3. Navy Orders 299 of 1942, 471 and 584 of 1944 are hereby cancelled.

(527/211/2162.)

206.

HALL SCOTT DEFENDER ENGINE OIL COOLER CORES.

The cooler element on the Hall Scott engine contains some 320 feet of bent thin-walled tubing. Elements are therefore expensive to repair and require considerable labour.

2. Considerable unnecessary mechanical damage to the delicate tubing has been noted.

3. Care is to be taken to avoid contact with the sharp edges of the cooler casing when cores are inserted or removed. The cores should be suitably protected in store and handled with care.

(546/201/521.)

207.

MODIFICATION OF TUMBLER HOOK OF MARK IV D.C. THROWERS.

With reference to Admiralty Fleet Order 6560/44, the modification referred to will be carried out by the Superintending Armament Supply Officer, R.A.N. Armament Depot, Spectacle Island, Sydney.

2. Ships concerned are to make a notation to this effect in their next lists of alterations and additions.

(471/205/2524.)

208.

COVERS BREECH RIFLE No. 2.

Covers, breech, rifle, No. 2, have been introduced into the Royal Australian Navy for protecting, against sand and mud, the actions of 0.303-in. rifles (other than rifles, M.L.E., line thrower, and rifles, No. 1, strengthened for firing grenades). Supplies are available for issue on the following scale:—

- H.M.A. Ships with an allowance of twelve or more 0.303-in. rifles—one to every two rifles.
- R.A.N. Beach Commando Units—30 per commando.
- Darwin, Thursday Island, and bases in New Guinea—one per rifle.

2. In addition to the allowances shown in paragraph 1, spare covers will also be supplied on the following basis:—

10 per cent. of the covers allowed for services shown in paragraphs 1 (a) and 1 (c).

50 per cent. of the covers allowed for R.A.N. Beach Commando Units referred to in paragraph 1 (b) above.

There should be a minimum allowance of one spare.

3. Ships are to demand requirements from the nearest naval armament depot or base. Base ports and other naval armament depots should demand requirements from the Superintending Armament Supply Officer, Spectacle Island, Sydney.

(612/203/3183.)

209.

AMERICAN 40 mm. AMMUNITION CLIP MARK 3—DEFECTS IN MANUFACTURE—STOPPAGES.

Reports have been received that American 40 mm. ammunition clips Mark 3, in which the saddle extended an excessive amount beyond the reinforcement, have caused jamming in the loaders of 40 mm. machine gun mechanisms.

2. To prevent gun stoppages caused by defective clips, clips Mark 3 are to be examined, and whenever the overhang of the saddle exceeds 1/16 in., the excess metal should be removed by filing or grinding. (Vide diagram appended to this Order.)

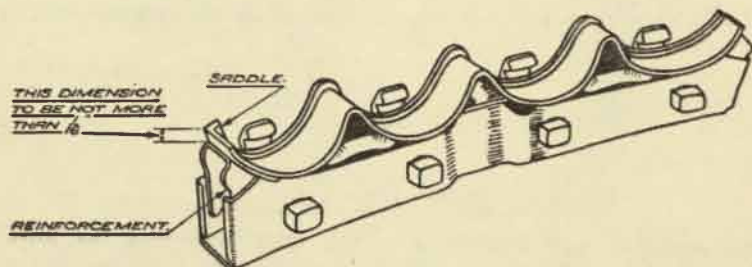

AMERICAN 40 MM. AMMUNITION CLIP MARK 3.

3. If this method of modification fails to prevent stoppages due to defective clips, a report of any additional difficulties encountered is to be forwarded to Navy Office. (Navord DCL A37-44. 13/5/44.)

(1810/2/308.)

210.

DEPTH CHARGE PISTOL MARK VII* REG. No. 4614.

With reference to Navy Order 684 of 1944, no report has yet been received of the whereabouts of depth charge pistol Mark VII* Reg. No. 4614. All depth charge pistols on board or in store are to be examined, and a report forwarded to Navy Office by the holder of this pistol stating what history sheet is held.

(471/205/2309.)

211.

GUNS, MACHINE, LEWIS .303-in.—CONVERSION OF MK. IV A.A. SIGHTS (100 KNOT) TO MK. V (200 KNOT)—FITTING MARK III BUTT PLATES TO GUN.

Admiralty Fleet Order 3556/43 is re-promulgated hereunder for information:—

“The following modification is approved:—

Gun	Lewis and Savage Lewis .303-in. except shoulder shooting gun.
Part affected	Sights A.A., Mark IV, and Butts.
Purpose	To provide 200 knot sights.
Drawing	N.O.D. 3115/6.
Nature of modification		(a) Sights—Sights A.A. fore and back, Mk. IV (100 knot) to be converted to Mk. V (200 knot). The new foresight holder is welded to the existing gun band and a 200-knot foresight ring assembled. The existing eyepiece support bracket is removed, reversed and fitted to left-hand side of butt. Cross wires are soldered to the existing eyepiece holders which with existing eyepiece holder plate are assembled with the new adjusting plate to the repositioned bracket. Sights A.A., Mark V, are required for one gun only of twin mountings.

(b) Butts—To be shortened to receive back sight holders and fitted with Mk. III butt plate. The butts of both guns in twin mountings are to be modified.

By whom to be done	R.N. Armament Depots.
New parts	Butt Plates, Mark III—to be provided locally. Holders, foresight; plates, adjusting back-sight; and rings, foresight 200 knot to be demanded from D.A.S.
Degree of urgency	As required.

2. It is to be noted that sights, A.A., Mark IV, are suitable for Lewis 303-in. machine guns converted to shoulder shooting *vide* A.F.O. 6279/42.

3. Parts displaced on conversion of sights A.A. Mark IV, are to be scrapped except where local stocks are required for replacement purposes.”.

2. The above-mentioned modification is to be carried out in respect of all guns machine Lewis 303-in. mounted in H.M.A. ships as A.A. weapons. Application should be made to the nearest naval armament depot or base for modification.

3. Depots or bases other than Sydney should obtain their requirements of conversion parts from the Superintending Armament Supply Officer, Sydney.

4. Navy Order 352 of 1944 refers.

(490/217/36.)

212.

MEDICAL AND DENTAL STORES—SUPPLY OF, IN NEW GUINEA AREA.

Demands from ships and depots in New Guinea area are to be made on Naval Medical Store, Madang, and not on the Medical and Dental Store Officer, Sydney, or U.S.A. sources. Until such time as dental stores are held at the Medical Store, Madang, demand for these is to be made on the Medical and Dental Store Officer, Sydney.

2. In cases of extreme emergency when stores cannot be obtained from R.A.N. sources, a small demand to meet the particular case only may be made on the Australian Army or R.A.A.F. store in the area.

3. It is to be noted that medical and dental stores previously supplied to the Royal Australian Navy from Allied sources, for which a signature has or has not been given, have been the subject of a claim for financial recovery from the Royal Australian Navy.

4. In forward operational areas where medical and dental stores from Australian sources are not available, they may be obtained from Australian Army, R.A.A.F. or R.N. stores or Allied sources provided (a) the need is urgent, and (b) they (or stores of a similar nature) are not available from Australian sources, e.g., American type syrettes are not to be demanded when the Australian type is available.

5. Navy Order 489 of 1944 is hereby cancelled.

(612/213/2669.)

213.

SUPPLY OF OFFICERS' UNIFORMS, INCLUDING W.R.A.N.S. OFFICERS AND R.A.N. NURSES.

The prices for the supply, by the Commonwealth Government Clothing Factory and the outfitters operating under an agreement with the Department, of officers' uniforms, including uniforms for W.R.A.N.S. officers and R.A.N. nurses, have been increased as shown in the schedule to this Order.

2. With the exception of greatcoats and shoulder straps, detachable, for R.A.N. and R.A.N.R.(S) Officers, it will be seen that separate prices are shown for hand-sewing and machine-sewing of lace on uniforms, and it is necessary that officers should, when ordering uniforms, specify clearly whether hand-sewing or machine-sewing of lace is required. In the case of greatcoats and shoulder straps for R.A.N. and R.A.N.R.(S) officers, hand-lacing only is provided for.

3. The revised prices of trousers are inclusive of such extras as fob and hip pockets and extension waistbands, if required.

4. The revised prices of uniform for W.R.A.N.S. officers and R.A.N. nurses are inclusive of the cost of hand-lacing, and separate prices are now shown for the various ranks.

5. The terms of the agreement, referred to in paragraph 1, provide for garments to be made to the complete satisfaction of the officer concerned, and any complaints in regard to service generally should be reported to his or her commanding officer for transmission, if necessary, to Navy Office.

6. The following are the names and addresses of the outfitters operating under the agreement referred to in paragraph 1:—

Melbourne.

Snows Men's Wear Ltd., Flinders-street.
Leviathan Ltd., c/r Swanston and Bourke streets.
*Ince Bros., 166 Swanston-street.
*Myer Emporium Ltd., Bourke-street.
†R. Simons and Sons, 313 Flinders-lane.

Sydney.

Anthony Hordern and Sons Ltd., Brickfield Hill.
F. Freeman and Sons, Smith-street, Surry Hills.
Vereys Ltd., King-street.

Adelaide.

The Myer Emporium (S.A.) Ltd., Rundle-street.

Hobart.

J. Bidencope and Sons Pty. Ltd., Murray-street.

Perth.

The National Clothing Co. Ltd., 40 King-street.

Brisbane.

Rothwells Outfitting Ltd., Edward-street.
Fred Ryder Pty., 15 Queen-street.

* Uniform of W.R.A.N.S. Officers and R.A.N. Nurses not included.

† Uniform of W.R.A.N.S. Officers and R.A.N. Nurses only.

7. Navy Orders 407, 458 and 660 of 1944 are cancelled.

(434/215/1102.)

SCHEDULE OF REVISED PRICES.

(A) UNIFORMS FOR R.A.N., R.A.N.R.(S), R.A.N.R. AND R.A.N.V.R. OFFICERS AND NAVAL CHAPLAINS' JACKETS, TROUSERS AND WAISTCOATS, TUNICS AND TROUSERS WHITE DRILL AND GREATCOATS.

(N.B.—The prices shown below for jackets and greatcoats do not include the cost of lacing. The prices for lacing, which are additional, are detailed below.)

	Cloth for Officers' Uniforms.	Lightweight Serge.	Diagonal Serge.	Drill, White.	Beaver Cloth.	Cloth, No. 3.
Jacket, undress—lacing extra (includes cost of gorget patches for midshipmen)	£ s. d. 5 14 0	£ s. d. 5 9 0	£ s. d. 5 4 6	£ s. d. ..	£ s. d. ..	£ s. d. ..
Trousers—including all extras	1 18 0	1 13 6	1 10 6
Waistcoats	1 8 6	1 7 6	1 6 6
Tunics, white drill, with buttons—shoulder straps extra	1 10 0
Tunics, white drill, without buttons—shoulder straps extra	1 7 0
Trousers, white drill	1 2 6
Greatcoats, fitted with plain shoulder straps—lacing extra	7 16 0	6 15 0
Jackets, undress, for chaplains—plain	5 14 0	5 9 0	5 4 6
Tunics or coats, white drill, for chaplains—shoulder straps extra	1 10 0
Greatcoats, for chaplains, fitted with plain shoulder straps—lace not worn	7 16 0	6 15 0

SCHEDULE OF REVISED PRICES—continued.

(B) LACING OF NAVAL OFFICERS' UNDRRESS JACKETS AND GREATCOATS INCLUSIVE OF COST OF LACE AND DISTINCTIVE CLOTHS.

	Undress Jackets.						Greatcoats.			
	Hand-sewn Lace.			Machine-sewn Lace.			Hand-sewn Lace.			Machine-sewn Lace.
	R.A.N.	R.A.N.R. (S) (non-metallic lace).	R.A.N.R. and R.A.N.V.R. (non-metallic lace).	R.A.N.	R.A.N.R. (S) (non-metallic lace).	R.A.N.R. and R.A.N.V.R. (non-metallic lace).	R.A.N.	R.A.N.R. (S) (non-metallic lace).	R.A.N.R. and R.A.N.V.R. (non-metallic lace).	R.A.N.R. and R.A.N.V.R. (non-metallic lace).
Midshipmen	£ s. d.	£ s. d.	£ s. d.	£ s. d.	£ s. d.	£ s. d.	£ s. d.	£ s. d.	£ s. d.	£ s. d.
*Midshipmen—of supply and other non-executive branches	0 7 6	0 6 0
Warrant officer	0 17 0	1 2 3	0 14 0	0 14 3	0 14 3	0 9 9	0 12 6	0 15 3	0 12 6	0 8 6
Warrant officer—of supply and other non-executive branches	0 19 3	1 4 6	0 16 0	0 16 6	0 16 3	0 12 0	0 14 3	0 17 3	0 14 0	0 9 0
Commissioned officer from warrant rank	1 2 6	1 2 3	0 14 0	1 0 0	0 14 3	0 9 9	0 16 0	0 17 3	0 12 6	0 8 6
Commissioned officer from warrant rank—of supply and other non-executive branches	1 4 9	1 4 6	0 16 0	1 2 0	0 16 3	0 12 0	0 17 9	0 18 6	0 14 0	0 9 0
Sub-Lieutenant	1 2 6	1 2 3	0 14 0	1 0 0	0 14 3	0 9 9	0 16 0	0 15 3	0 12 6	0 8 6
Sub-Lieutenant—of supply and other non-executive branches	1 4 9	1 4 6	0 16 0	1 2 0	0 16 3	0 12 0	0 17 9	0 17 3	0 14 0	0 9 0
Lieutenant	1 10 9	1 14 9	1 1 0	1 5 3	0 18 6	0 12 3	1 3 3	1 0 9	0 19 3	0 9 9
Lieutenant—of supply and other non-executive branches	1 13 3	1 17 6	1 3 6	1 8 0	1 1 3	0 14 9	1 5 3	1 3 0	1 0 9	0 10 6
Lieutenant-Commander	1 16 3	1 18 6	1 6 6	1 8 3	1 0 9	0 14 3	1 7 3	1 5 0	1 2 0	0 11 6
Lieutenant-Commander of supply and other non-executive branches	1 19 0	2 1 9	1 9 0	1 10 9	1 3 6	0 16 9	1 9 3	1 7 3	1 3 6	0 12 3
Commander	1 18 9	2 7 3	1 6 6	1 10 9	1 3 0	0 14 6	1 12 9	1 9 0	1 4 9	0 11 6
Commander—of supply and other non-executive branches	2 1 6	2 10 0	1 9 0	1 13 3	1 5 6	0 17 0	1 14 9	1 11 3	1 6 3	0 12 0
Captain	2 7 0	2 19 9	1 13 6	1 16 0	1 7 3	0 16 6	2 3 3	1 18 6	1 10 6	0 13 6
Captain—of supply and other non-executive branches	2 9 6	3 2 6	1 16 0	1 18 9	1 9 9	0 19 0	2 5 3	2 0 9	1 11 9	0 14 3

* Distinctive cloth only.

SCHEDULE OF REVISED PRICES—*continued.*

(C) SHOULDER STRAPS (DETACHABLE) FOR WHITE DRILL TUNICS INCLUSIVE OF THE COST OF ALL MATERIALS.

	Hand-Sewn Lace.			Machine-Sewn Lace.		
	R.A.N.	R.A.N.R. (S) (non-metallic lace).	R.A.N.R. and R.A.N.V.R. (non-metallic lace).	R.A.N.	R.A.N.R. (S).	R.A.N.R. and R.A.N.V.R. (non-metallic lace).
	£ s. d.	£ s. d.	£ s. d.			£ s. d.
Midshipmen—of supply and other non-executive branches ..	0 13 6					
Warrant officer ..	1 0 0	1 2 9	1 0 0			0 16 0
Warrant officer—of supply and other non-executive branches ..	1 1 9	1 4 9	1 1 6			0 16 6
Commissioned officer from warrant rank ..	1 3 6	1 4 9	1 0 0			0 16 0
Commissioned officer from warrant rank—of supply and other non-executive branches ..	1 5 3	1 6 0	1 1 6			0 16 6
Sub-Lieutenant ..	1 3 6	1 2 9	1 0 0			0 16 0
Sub-Lieutenant—of supply and other non-executive branches ..	1 5 3	1 4 9	1 1 6			0 16 6
Lieutenant ..	1 10 9	1 8 3	1 6 9			0 17 3
Lieutenant—of supply and other non-executive branches ..	1 12 9	1 10 6	1 8 3			0 18 0
Lieutenant-Commander ..	1 14 9	1 12 6	1 9 6			0 19 0
Lieutenant-Commander—of supply and other non-executive branches ..	1 16 9	1 14 9	1 11 0			0 19 9
Commander ..	2 0 3	1 16 6	1 12 3			0 19 0
Commander—of supply and other non-executive branches ..	2 2 3	1 18 9	1 13 9			0 19 6
Captain ..	2 10 9	2 6 0	1 18 0			1 1 0
Captain—of supply and other non-executive branches ..	2 12 9	2 8 3	1 19 3			1 1 9
Chaplain—plain shoulder strap—(lace not worn) ..	0 7 6		0 7 6			

SCHEDULE OF REVISED PRICES—*continued.*

(D) UNIFORM FOR W.R.A.N.S. OFFICERS AND R.A.N. NURSES.

(N.B.—The prices shown below are inclusive of the cost of lacing.)

	Jackets made of Lightweight Serge.	Skirts made of Lightweight Serge.	Jackets made of Diagonal Serge.	Skirts made of Diagonal Serge.	Greatcoats made of Cloth No. 3
	£ s. d.	£ s. d.	£ s. d.	£ s. d.	£ s. d.
W.R.A.N.S. Officers—					
3rd Officer ..	5 14 3	1 12 6	5 10 6	1 10 0	7 1 0
2nd Officer ..	5 16 9	1 12 6	5 13 3	1 10 0	7 2 3
1st Officer ..	5 18 9	1 12 6	5 15 3	1 10 0	7 4 0
Chief Officer ..	5 19 0	1 12 6	5 15 6	1 10 0	7 4 0
R.A.N. Nurses—					
Sister ..	5 16 6	1 12 6	5 13 0	1 10 0	7 1 6
Superintending Sister ..	5 19 3	1 12 6	5 15 9	1 10 0	7 3 0
Matron ..	6 1 3	1 12 6	5 17 9	1 10 0	7 4 9

Capes—(All Nurses)—made of Lightweight Serge or Cloth No. 3—£1 12s.

214.

**CHARGE FOR ACCOMMODATION OF R.N., DOMINION AND ALLIED
NAVAL PERSONNEL.**

With reference to Navy Orders 241 of 1941 and 148 of 1942, consequent on the waiver as from 1st April, 1944, of training fees in respect of New Zealand personnel, the charge for accommodation will now apply to New Zealand personnel.

2. Attention is also invited to the fact that the quarterly statements of personnel accommodated are required in duplicate.

(407/213/428.)

215.

NAVAL CENSORSHIP.

With reference to Navy Order 23 of 1944, paragraph 16 is to be amended by deleting the words—"south of latitude 20° S.," and inserting in lieu the words "south of latitude 14° S.,".

(1835/2/534.)

RESTRICTED.(FOR OFFICIAL USE ONLY.)**Commonwealth Navy Order.**

Navy Office, Melbourne,

22nd May, 1945.

The following Order, having been approved, is hereby promulgated for information and guidance, and necessary action.

By direction of the Naval Board,

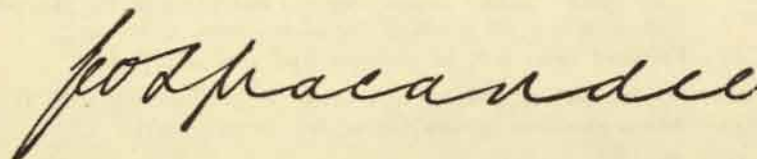

Secretary.

*The Commodore Commanding H.M.A. Squadron,
and Commanding Officers of H.M.A. Ships,
Officers in Charge of H.M.A. Naval
Establishments, and others concerned.*

TABLE OF CONTENTS.

No.	Subject.
216.	Machinery Spares—Arrangements for Storing and Issuing, &c., in Mobile Bases, Bases and Establishments other than the Central Machinery Spares Depot, Sydney.

216.

MACHINERY SPARES—ARRANGEMENTS FOR STORING AND ISSUING, ETC., IN MOBILE BASES, BASES AND ESTABLISHMENTS OTHER THAN THE CENTRAL MACHINERY SPARES DEPOT, SYDNEY.

This Order is applicable to the following mobile bases, bases and establishments:—

Mobile Bases.	Main Overhaul Bases.	Base Spare Depots.	Forward Bases.
H.M.A.S. <i>Platypus</i> H.M.A.S. <i>Whang</i> <i>Pu</i>	H.M.A.S. <i>Penguin</i> Brisbane (Colmslie)	Brisbane Alexishaven Thursday Is. Darwin Fremantle Port Adelaide Port Melbourne	Will be allocated as requisite

2. (a) Mobile bases will be informed of their authorized establishments from time to time.
- (b) Main overhaul bases are to endeavour to carry stocks up to the establishments authorized for the engines which they are maintaining.
- (c) Base spares depots are to maintain stocks in accordance with authorized establishments for top overhauls of the engines of certain craft working out of the port.
- (d) Forward bases will be given special authorizations.

3. Navy Order 666 of 1944 is to be read in conjunction with this Order and, unless qualified by this Order, will be applicable.

4. It is emphasized that machinery spares are very scarce and there is no immediate prospect of appreciable improvement in their supply. This will inevitably result in available stocks being rationed, so that it is unlikely that, in the near future, full establishments will be possible. As a general policy, it will be necessary for vessels to forward requisitions to machinery spares depots for all machinery spares required, whether for first supply or for replenishments.

5. (a) It will be necessary at all ports except Sydney for existing stocks of machinery and machinery spares to remain on charge in naval store accounts until such time as the base machinery spares depot is ready to operate. Information thereof will be promulgated by Navy Order as each depot becomes available for use.
- (b) Notwithstanding the preceding sub-paragraph (a), after the date of this Order, all requisitions for machinery and machinery spares are to be raised and forwarded by the appropriate base engineer officer to the Central Machinery Spares Depot, Sydney.

The base engineer officer is to receive and store all such supplies (except *existing* stocks now on charge in naval store accounts), authorize issues and keep a record of all receipts and issues in a manuscript book pending receipt of the card accounting equipment.

(c) When each machinery spares depot has obtained its card accounting system, binning, &c., and is ready to operate, as indicated by the base engineer officer, all stocks of machinery and machinery spares on charge in naval store accounts are to be transferred to him on Forms S.549. The Naval Board is to be informed as each transfer is completed.

(d) Shipping at all ports except Sydney is to be continued by the existing organization pending instructions for variation.

6. Information.

General principles for receiving, storing, issuing and accounting for machinery spares are set out in six brochures, bound as one document, which were compiled by the General Motors Corporation, Detroit, U.S.A., for the U.S. War Department, a copy of which will in due course be forwarded to each base for information. These brochures are not to be considered as instructions, but as supplementing information given in Navy Orders, &c.

7. Selection of suitable store space.

(a) *At Main Overhaul Bases.*

The preferred layout for a small 570 bin store is shown on diagram No. 500/27, appended to this Order. This arrangement can be increased proportionately to suit the local commitment for machinery spares.

The essentials to arrange for are—

- (i) A receiving section, preferably with suitable lifting and traversing equipment. The space should be adequate for stacking incoming packages awaiting opening up, receiving and putting away.
- (ii) A storage section with suitable bins, racking and stacking area.
- (iii) A despatch section, including facilities for boxing up, if parts have to be sent away from the depot.
- (iv) For security, the store should preferably be a separate building fitted with proper lockup facilities. If it is in a building which is to be used for other purposes, an adequate area should be partitioned off. Chain wire fencing from the full height from floor to ceiling or roof may be used for this purpose. It is essential that packages immediately on arrival are taken into the receiving section, so as to be stored out of the weather and safe from pilfering while awaiting inspection, opening up, receiving and storing, &c.
- (v) The building should be well constructed, weather proof, with concrete, bitumen-covered or wood floors and reasonably free from dust nuisance.
- (vi) The equipment required for the purpose of operating the store is set out in the appended diagram, and the steel shelving, binning, and "Kardex" equipment, should be requisitioned from the Central Machinery Spares Depot, Sydney.

NAVY OFFICE MELBOURNE

DRG. NO 500/27

DATE - 8 / 1 / 45

COPY NO. MS.

DRAWN BY *W.H.* 8-1-45TRACED BY *W.H.* 8-1-45CHECKED BY *W.H.* 15-1-45EXAMINED BY *W.L.R.* 18-1-45
MSA/BEIN

APPROVED

W.L. Reilly

BASE MACHINERY SPARES DE
TYPICAL ARRANGEMENT OF 5TH STORE
WITH APPROPRIATE PILING SPACE
AREA 2,000 SQ. FT.

PROVIDE SERVICES AS UNDER

1. RECEIVING AND DISPATCH AREA
2. PILING AREA
 - A. 160 STORE BINS - EACH TIER - 7'11" x 3'0" x 1'0"
 - TYPE A BINS 6'46" x 12" 4 TIERS 640 BINS
 - TYPE B BINS 12'12" x 12" 4 TIERS 64 BINS
 - TYPE C BINS 12'12" x 12" 4 TIERS 64 BINS
 - TYPE D BINS 12'12" x 12" 4 TIERS 64 BINS
3. COUNTER 3'0" x 2'6" x 3'6"
4. PACKING TABLE 8'0" x 4'0" x 2'6"
5. UNPACKING TABLE 3'0" x 4'0" x 2'6"
6. STOREHOUSEMAN'S OFFICE - FITTED WITH:
 - 2 NO. TABLES 4'6" x 2'6"
 - 3 NO. FIXED CHAIR
 - 1 NO. TELEPHONE
 - 1 NO. FILING CABINET
7. HAND TROLLEYS AND LIFTING FACILITIES FOR HANDLING SPARE ENGINES.
8. RECEIVING, PILING AND STORAGE AREAS ARE TO BE MARKED OUT WITH 2" WHITE BORDER LINES.
9. HEAVY DUTY FLOOR IS TO BE FITTED FOR LOADING UP TO 300 LBS. PER SQ. FT. FLOOR SHOULD BE REASONABLY FREE FROM DUST, AND SHOULD PREFERABLY BE OF CONCRETE.
10. FIRE FIGHTING FACILITIES
11. SECURITY OF STORE IS TO BE MAINTAINED. LOCKS AND BOLTS ARE TO BE FITTED TO ALL DOORS. WINDOWS SHOULD BE MADE SECURE AGAINST UNLAWFUL ENTRY.

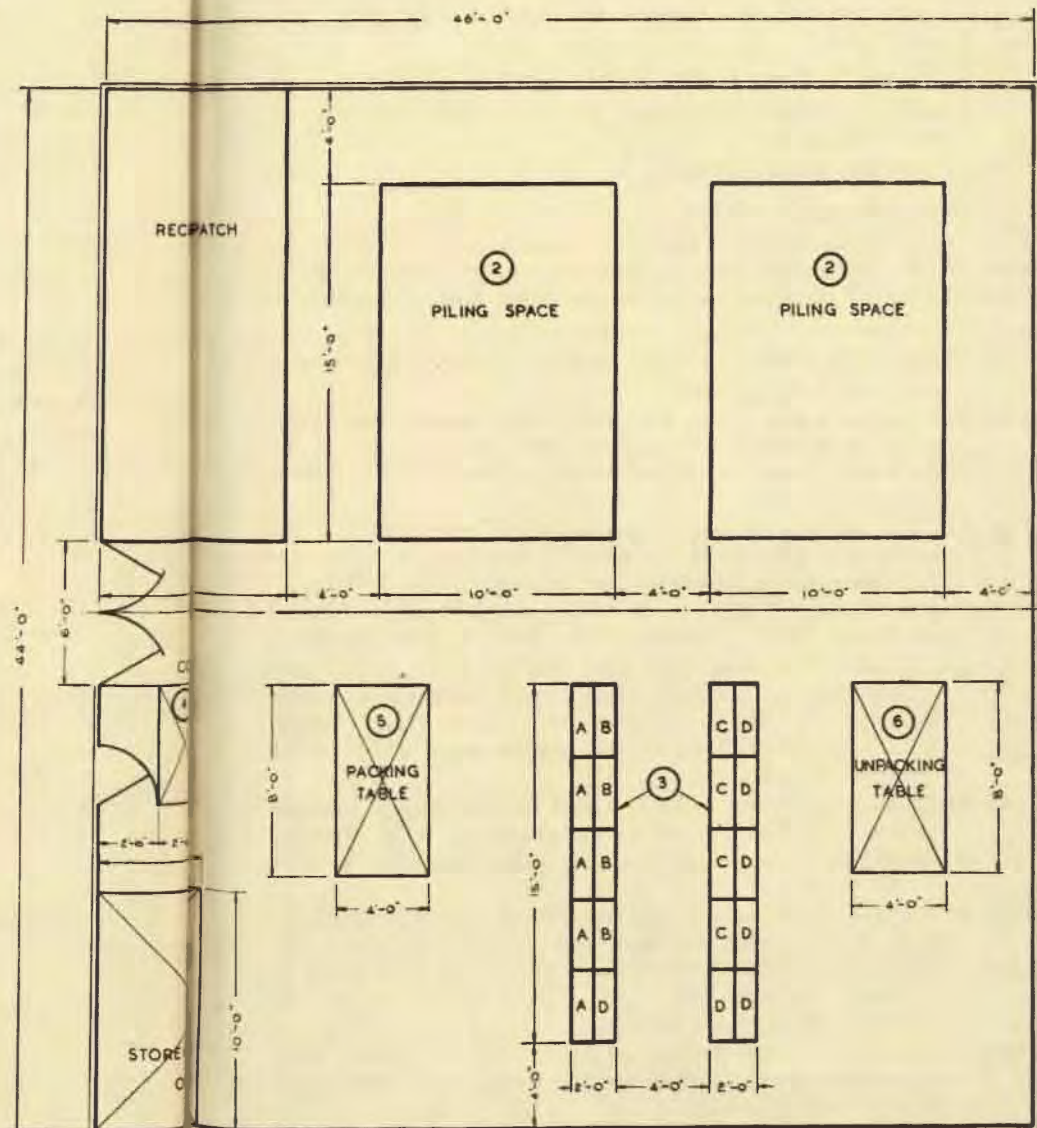

(b) At Base Spares Depots.

At the depots, arrangements are to be similar to those at main overhaul bases.

(c) At Forward Bases.

At forward bases, the requirements vary considerably. The minimum requirement is that the machinery spares should be stowed in a lockable box kept under cover and raised off the ground so as to permit the free circulation of air. Store structures or arrangements should comply with tropic proofing requirements, the chief of which are—

- (i) a sound roof;
- (ii) a dry floor (adequate drainage is important);
- (iii) adequate ventilation within the structure and between packages; and
- (iv) security against pilfering.

8. System of records and forms.

(a) At forward bases, the minimum requirement is that an acceptance of the particular package and its contents must be given on the return copy of the store invoice to the depot making supply.

(b) At other bases, the system of accounting is to be as follows:—

- (i) The operations of receiving, recording, storing and issuing are to be fully covered.
- (ii) The proper forms to use are listed in the attached Schedule, which also covers the correct end use, and are to be demanded from the Superintending Naval Store Officer, Sydney.
- (iii) On receipt of packages, a proper receiving report is to be made out (Form M.S./D.E.(N) B-28). If there are discrepancies in quantities or damage, "over," "short," and "damage" reports are to be made out and forwarded to Navy Office. (Forms M.S./D.E.(N) 30A-30B-30C).
- (iv) In the store, bins, racks and stacking areas are to be properly indexed by a location system and machinery spares inwards are to be tagged with parts tags (Form M.S./D.E.(N) 15) ready for putting away while in the receiving station.
- (v) Stock movements are to be recorded on a "Kardex" system (Form M.S./D.E.(N) B-1) on which are to be recorded items received, issued, balances remaining and location in the store.
- (vi) Issues are to be made only against Form M.S./D.E.(N) B-20 for internal services, and Form M.S./D.E.(N) B-22 for external services, which must be authorized by the base engineer officer, or, for mobile bases, by the engineer officer of the ship.
- (vii) Inspectors will visit depots, establishments and mobile bases to examine the methods in use and report on the machinery spares stores generally.

9. Parts lists for internal combustion engines of all types are being prepared and will be issued when completed to ships, bases and establishments,

These lists will be amended from time to time and will be as under—

List "A"—On board spares.

List "B"—Top overhaul base spares.

List "C"—Major overhaul base spares.

10. Upon receipt of the information contained in these lists, existing spares carried are to be checked and discrepancies noted. *All deficits* are to be requisitioned on Form M.S./D.E.N.(N) 17. *Any surplus* is to be reported.

SCHEDULE.

LIST OF FORMS FOR USE IN CONNECTION WITH MACHINERY SPARES AT BASES.

Form Number.	Name.	Use.
M.S./D.E.(N) B-1	Stock Movement Card	To record all receipts and issues of stock items, together with the location of the item. A separate card is to be raised for each item.
M.S./D.E.(N) 7	Parts Tag	All parts are to be tagged both on receipt and issue. Parts tags are to be raised by office when picking for issue and should be forwarded with Form M.S./D.E.(N) B-20 or M.S./D.E.(N) B-22.
M.S./D.E.(N) 15	Bin Card	To indicate the item in stowage in the respective bin; to be on the bin front.
M.S./D.E.N.(N) 16	Bin Tally Card	For store record only. All stock movements are to be recorded by storehouseman.
M.S./D.E.(N) B-20	Store Invoice	Form raised in sextuplicate by office for all issues of stocks for internal service requirements. Copies Nos. 3 and 4 are to be forwarded together with M.S./D.E.(N) 7 for use in picking parts.
M.S./D.E.(N) B-22	Store Invoice	Similar Form as M.S./D.E.(N) B-20 but for external services such as Royal Navy, A.M.F., R.A.A.F., &c.
M.S./D.E.(N) B-28	Receipt and Survey	Form raised in triplicate and is to cover receipt of all stock received.
M.S./D.E.(N) 30A, 30B, 30C	"Over," "Short" and "Damage" Reports	Forms are to be raised as noted thereon for any stock not conforming to the Bill of Lading.
M.S./D.E.(N) 31	Yard Return Note	This form is to be used for receipt of stock issued on temporary loan and returned to store.

(549/201/148.)

any
RESTRICTED.(FOR OFFICIAL USE ONLY.)

Commonwealth Navy Orders.

Navy Office, Melbourne,
29th May, 1945.

The following Orders, having been approved, are hereby promulgated for information and guidance and necessary action.

By direction of the Naval Board,

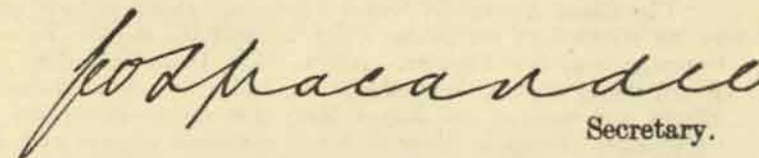
Secretary.

*The Commodore Commanding H.M.A. Squadron,
and Commanding Officers of H.M.A. Ships,
Officers in Charge of H.M.A. Naval
Establishments, and others concerned.*

TABLE OF CONTENTS.

No.	Subject.
217.	Cessation of Hostilities in Europe.
218.	Relief of Personnel and Leave—Northern Areas.
219.	Temporary Engineering Commissions—Selection of Ratings from the Lower Deck.
220.	Procedure in Regard to Supply, Replenishment and Accounting for Naval Stores in Radar and A/S Repair and Maintenance Vessels.
221.	Fire Precautions in Cinema Projection Rooms.
222.	O.Q.F. 40-mm. Bofors Mark I*—Springs Striker Inner and Outer.
223.	Valves for W/T, Radar, etc., Services—Accounting.
224.	Naval Armament Stores Issued by U.S. Authorities.
225.	Books and Forms.

217.

CESSATION OF HOSTILITIES IN EUROPE.

The following message has been received from the Admiralty on the occasion of cessation of hostilities in Europe:—

“On the occasion of the cessation of hostilities in Europe the Board of Admiralty desire to convey to the Australian Commonwealth Naval Board their sincere appreciation of the very valuable services rendered and still being rendered by the Royal Australian Navy in the war at sea. They recall in particular the gallant actions fought by units of the Royal Australian Navy in the Mediterranean as well as in the Pacific and Indian Oceans.

2. They also wish to extend their gratitude to the Australian Commonwealth Naval Board for their welcome and constant assistance to the British Pacific Fleet.

3. They look forward to the continued co-operation of the Royal Australian Navy in bringing about the early defeat of Japan, the sole remaining member of the Axis, and thus finally liberating the world from fear and aggression.”

2. The Naval Board have thanked the Admiralty for their message and replied:—

“The Royal Australian Naval Forces are proud to have shared in the triumph of sea power which assured the decisive defeat of Germany and her European Allies. The Commonwealth Naval Board would express their admiration and gratitude to the gallant officers and men of the Royal Navy for their outstanding contribution to victory by their skill and relentless courage over more than 5 years of desperate conflict. We are greatly heartened by the presence of the British Pacific Fleet, and welcome the opportunity for continued association and co-operation in the defeat of Japan.”

(462/201/2342.)

218.

RELIEF OF PERSONNEL AND LEAVE—NORTHERN AREAS.

In view of the circumstances attending conditions of service on shore in Darwin and at other places in northern areas (as specified in paragraph 12 of this Order), and in vessels employed in such areas which do not periodically proceed to southern bases for refit, it has been decided that personnel will normally be relieved after completing 12 months' service, as far as the necessary reliefs are available.

2. Personnel so relieved will be granted leave on the expiration of their period of service.

3. In the case of personnel drafted to shore service at places to which this Order applies, who have previously been serving afloat in sea-going ships stationed in northern areas, continuous sea service between the latitudes of 15° North and 15° South since the last long leave and immediately prior to the commencement of shore service within these latitudes shall be deemed to be portion of the qualifying period for relief from such shore service, and shall be taken into account when calculating the date of relief.

4. Similarly, continuous shore service in one or more places to which this Order applies shall be deemed to be portion of the qualifying period for relief from such shore service, and shall be taken into account when calculating the date of relief.

5. Personnel who have already taken interim leave from an area covered by this Order will not be regarded as due for relief until they have completed 15 months' service exclusive of time absent from the area on leave.

6. A monthly return is to be rendered by the commanding officer to the Naval Officer-in-Charge, Flinders Naval Depot, giving the names of ratings who will complete 12 months' service in the area within the ensuing 2 months, and indicating any who volunteer for further 12 months' service in the area.

On receipt of this return, the Naval Officer-in-Charge, Flinders Naval Depot, is to cause the commanding officer concerned to be furnished with information regarding those ratings who will be relieved when due, or the anticipated dates of relief, after completion of the 12 months' period.

7. A similar return in respect of officers is to be rendered to Navy Office and action will then be taken in respect thereof on the lines indicated in the preceding paragraph.

8. On receipt of information that personnel will not be relieved at the expiration of 12 months' service or within 3 months thereafter, immediate consideration should be given to the grant of leave, and up to 24 days exclusive of travelling time may be granted if personnel can be spared without relief.

9. Personnel proceeding on leave are to travel by the most expeditious route, utilizing service aircraft if accommodation is available, and passage to destination is thereby expedited.

10. Darwin personnel, other than Queensland natives, should proceed on leave and return via Adelaide utilizing service air transport if available, otherwise by rail and road via Alice Springs. Queensland natives are similarly to proceed via Townsville if travelling by overland route, or direct to and from Brisbane if travelling by service aircraft. *Melville* is to inform *Torrens*, *Magnetic*, and *Moreton*, respectively, of the numbers travelling and the dates of expiration of leave; return passages are to be arranged accordingly.

11. Personnel on leave from Thursday Island and bases outside the mainland are, on completion of leave, to be sent to *Penguin* to await return passage. This instruction is to apply to personnel taking leave from Brisbane or Townsville unless the respective Naval Officers-in-Charge are aware of an early opportunity for direct sea passage or air passage is ordered. Depots concerned are to be advised of numbers travelling and dates of expiration of leave, and return passages are to be arranged accordingly.

12. The instructions contained in this Order are applicable to Darwin, Thursday Island, Port Moresby, and any other bases which may be established in New Guinea or elsewhere between the latitudes of 15° North and 15° South, and the respective commanding officers will take action accordingly.

13. Navy Orders 410 of 1942, 680 of 1944, and 105 of 1945 are cancelled.

(520/201/1190.)

219.

TEMPORARY ENGINEERING COMMISSIONS—SELECTION OF RATINGS FROM THE LOWER DECK.

The Naval Board have decided that engine room artificers and ordnance artificers, R.A.N.R. and motor mechanics R.A.N. (H.O.) may now be considered for promotion to commissioned rank in the engineering branch, R.A.N.V.R.

2. Forms C.W.1 may be commenced for suitable ratings at any time.

3. Ratings who have the requisite technical knowledge, character, personality and powers of leadership may be recommended without regard to any particular educational standard.

4. Recommended candidates will be drafted to Flinders Naval Depot for disciplinary and technical courses as requisite before final selection and promotion to commissioned rank.

5. On satisfactory completion of the technical courses and recommendation, candidates will be promoted to midshipman (E) (O.P.) R.A.N.V.R., if under the age of 19½, and acting sub-lieutenant (E) (O.P.) R.A.N.V.R., if over 19½.

Candidates who have attained the rating of E.R.A., 4th Class, or O.A., 4th Class (confirmed), or motor mechanic 3rd Class, or higher rating, will be promoted direct to the rank of temporary sub-lieutenant (E) R.A.N.V.R. Care should therefore be exercised in ensuring that the candidate's correct rating is reported.

Further promotion in the R.A.N.V.R. will be in accordance with the conditions laid down in A.F.O. 4995/44.

6. Successful candidates on completion of courses and on promotion will then be appointed additional for training to vessels, similar to those in which they will subsequently be employed, for a period not exceeding six months. Such appointments will normally be to sloops, frigates, and minesweepers, although appointments may be made to other types of vessels from time to time.

During this period of training afloat and when the officer is considered fit in every respect, the commanding officer is to award a certificate, to be known as the small ship certificate, as follows:—

“(Rank).....(Name).....is considered fit to carry out the duties of the Engineer Officer of—

(a) a small steam or Diesel ship; or

(b) a small steam ship; or

(c) a small Diesel ship;”

in whichever form is applicable having regard to the officer's training and experience. (a) denotes that the officer has experience of both steam and Diesel ships, and is equally competent to serve as the engineer officer in either type.

A copy of the certificate is to be forwarded at the same time to the Naval Board.

If at the end of the six months' period the Commanding Officer does not consider that the certificate can be awarded, a report on the officer is to be forwarded to the Naval Board.

7. Candidates who fail to attain a sufficiently high standard at the end of any of the above courses or who show they are unsuitable for promotion during the courses will revert to their previous duties.

8. Officers promoted under this scheme will be paid executive branch rates of pay until the certificate in accordance with paragraph 6 above is obtained. They will receive (E) rates of pay from the date of the award of the certificate.

(568/202/925.)

220.

PROCEDURE IN REGARD TO SUPPLY, REPLENISHMENT AND ACCOUNTING FOR NAVAL STORES IN RADAR AND A/S REPAIR AND MAINTENANCE VESSELS.

The following procedure is to be observed in connexion with the supply, issue, accounting, etc., of A/S radar, and other naval stores required to be carried in radar and A/S, repair, and maintenance vessels as stock for issue for repair, etc., of A/S and radar equipment of other vessels.

2. As these craft are not issuing vessels, only such small quantities as are required for maintenance purposes are to be carried on board. The quantities considered essential for this purpose should be worked out by the A/S or radar officer concerned and the supply officer of the naval store issuing ship or the parent ship or base.

3. The quantities referred to in paragraph 2 are to be drawn from the naval store issuing ship or the parent ship or base, but will remain on the charge of the supply officer. The items will not be written off charge in the naval store account of the naval store issuing ship or the parent ship or base pending issue for the repair, etc., of other vessels.

4. In the case of repair, etc., vessels for maintenance of escort vessels, the supply officer of the naval store issuing ship, parent ship or base, should detail a stores rating from his store staff to proceed

in the repair, etc., vessel to make issues as necessary and obtain the requisite receipts, which should subsequently be posted in the naval store account of the naval store issuing ship, or the parent ship or base, from which replenishment of items carried in the repair vessels is to be effected.

5. (a) In the case of repair, etc., vessels for maintaining M.L. flotillas, the quantities referred to in paragraph 2 are to be drawn from the supply officer of the parent ship or base on temporary loan, a receipt being furnished by the commanding officer of the maintenance vessel on forms A.S.1092. Such items will remain on charge in the naval store account of the parent ship or base until written off charge therein from receipts obtained from M.Ls. to which issued by the maintenance vessel for repair, etc., purposes.

(b) Receipts for issues of consumable naval stores from the maintenance vessel should be obtained in counter books, forms A.S.149. In the case of permanent naval stores, receipts for issues should be obtained by the commanding officer of the maintenance vessel on form A.S.156 and, where issues are made in lieu of permanent items returned, receipts for the latter items should be furnished by the commanding officer of the maintenance vessel on form A.S.1091.

(c) On completion of each routine voyage, vouchers on forms A.S.149 and A.S.156 should be produced by the commanding officer of the maintenance vessel to the supply officer of the parent ship or base for all stocks issued.

Similar quantities of items to those shown thereon should be supplied to the maintenance vessel, thus maintaining in the vessel the original quantities issued on loan *vide* paragraph (b) above.

The issue vouchers referred to should be used to write the item involved off charge in the naval store account of the parent ship or base, any necessary amendments in the inventory naval store accounts of the M.Ls. to which supplies were made being also effected. (*Vide* Navy Order 632 of 1943.)

(d) In the case of unserviceable, etc., items returned to the maintenance vessel *ex* M.Ls., the items returned, together with the appropriate forms A.S.1091, should be transferred by the commanding officer of the maintenance vessel to the supply officer of the parent ship or base. The supply officer of the parent ship or base should at intervals check the duplicate vouchers A.S.1091 in the bound books held in the M.Ls. to ensure that all returns to the maintenance vessel have been duly transferred to him.

(e) It is the responsibility of the supply officer of the parent ship or base to ensure that the storekeeping procedure is fully carried out, and he should issue explanatory notes, etc., as necessary for the information of personnel of the M.Ls. and maintenance vessel.

6. The above procedure applies only to items drawn for issue for repair, etc., of equipment for other ships and does not affect the ordinary naval stores required for operation and maintenance of repair ships, which should be dealt with in accordance with the procedure applicable to vessels of this type.

(612/226/1276.)

221.

FIRE PRECAUTIONS IN CINEMA PROJECTION ROOMS.

In view of the possibility of phosgene gases being generated when Pyrene (carbon-tetrachloride) extinguishers are used on film fires, it has been decided to replace that type by CO₂ extinguishers.

2. Extinguishers CO₂ type should be demanded from the nearest Naval Store Officer, and Pyrene type returned.

3. Master control switches for projectors are to be placed outside the projector room door in an accessible position, *vide* paragraph 12 (b) of A.F.O. 5938/43.

4. An operator is to be in constant attendance at the projector whenever it is running. Should rewinding be necessary during the showing of the film, a second person must be present at the projector in order to open the switches in the event of fire or breaks in the film.

(475/201/233.)

222.

O.Q.F. 40-MM. BOFORS MARK I*—SPRINGS STRIKER INNER AND OUTER.

A number of 40-mm. Bofors guns of Australian manufacture has been issued to Service with the inner and outer striker springs wound to the same hand. This is unsatisfactory, as the inner spring is not properly supported, entailing a risk of premature fatigue, fracture of the springs and of jams, which may cause serious damage to the breech mechanism.

2. All component springs striker are therefore to be examined to ensure that the inner and outer springs are wound to opposite hands, i.e., left hand inner and right hand outer, *or* right hand inner and left hand outer, and exchanges affected as necessary.

3. Demands for springs are to be forwarded as necessary to the nearest naval armament depot. Whenever single springs are demanded, the demand is to specify whether springs wound to right or left hand are required.

4. Navy Order 567 of 1944 is cancelled.

(490/212/1168.)

223.

VALVES FOR W/T. RADAR, ETC., SERVICES—ACCOUNTING,

The provisions of A.F.O. 4683/44 regarding the institution of a new item 4 of subhead "F" for all W/T. radar, etc., valves and the supersession of existing pattern and service reference numbers by the new "C.V." (common valve) numbers are to be adopted in the Royal Australian Navy.

2. Attention is particularly drawn to the necessity for demand and return notes to indicate both the new "C.V." number and the original type or reference number until the use of the former has become well established.

3. With regard to disposal of unserviceable valves referred to in paragraph 12 of the A.F.O., the following procedure is to apply in the R.A.N.:—

- (a) Defective valves, glass, of types unsuitable for repair (referred to in Appendix A, section A of A.F.O. 4683/44) to be transferred to local Army salvage organizations at the bases concerned after necessary survey has been carried out.
- (b) All other types of defective valves, including cathode ray tubes, silica valves, etc., to be returned to the nearest naval store depot for onward despatch to the Superintending Naval Store Officer, Sydney, for disposal.
- (612/246/3214.)

224.

NAVAL ARMAMENT STORES ISSUED BY U.S. AUTHORITIES.

Reports have been received of the issue of weapons, e.g., pistols, by the U.S. Authorities to R.A.N. personnel on detached duty. All concerned are reminded that any naval armament stores issued by U.S. Authorities are to be taken on charge in the appropriate store account, a copy of the receipt given to the U.S. officer being kept with the account. This instruction covers weapons issued personally to officers and ratings.

2. In the case of personal issues, the person concerned is to obtain from the issuing officer a copy of his receipt and is to send it to the storekeeping officer at the base, who will take the article on charge and re-issue it on loan to the holder.

(432/212/4233.)

225.

BOOKS AND FORMS.

First supplies of the under-mentioned publications have been distributed. Further supplies of B.Rs. 155B, 257(1), 765, 766, and 888 are being obtained to complete distribution:—

Amendment No. 6 to B.R.150.—Manual of Aircraft Recognition.
(A.F.O. 5599/44.)
(571/202/1646.)

B.R.155B/1944.—Instructions for Use and Maintenance of the Admiralty Shallow Water Diving Dress (Addendum to B.R.155/43 and B.R.155A/43).

(A.F.O. 3349/44.)
(571/202/1863.)

B.R.257 (1).—Addendum to B.R.257.—Handbook for the 4-in. Q.F. Mark XVI* Gun on the H.A. Twin, Mark XIX and Single Mark XX Mountings for 4-in. H.A. Twin, Mark XIX Mountings fitted with R.P. 50, 51 and 52.

(A.F.O. 4665/44.)
(571/202/1440.)

B.R.276/44.—Instructions for Flying Admiralty Kites and Balloons.

(A.F.O. 6771/44.)
(571/202/1573.)

List of Errata Nos. 11 and 12 to B.R.332A.—Establishment of Naval Stores for Flotilla Leaders and Destroyers and Form D.117B—List of Particulars.

(A.F.Os. 2274/44 and 346/45.)
(571/202/1393.)

B.R.669 (1).—Cash Duties Instructions—Addendum No. 1.

(A.F.O. 474/45.)
(571/202/1712.)

B.R.765/1944.—Combined Operations Gunnery Instructions (11) and Amendment No. 1.

B.R.766/1944.—Combined Operations Signal Book 11.

(A.F.O. 5103/44.)
(571/202/1693.)

B.R.888/1944.—Handbook of the R.N. Sick Berth Staff.

(A.F.O. 3083/44.)
(571/202/1886.)

B.R.920.—Preliminary Pamphlet on the Dome Tracer Gun—Revision of B.R.920.

(571/202/1870.)

B.R.992/1939.—Handbook for the Ordnance Q.F. 6 Pdr. 10 cwt. Mark I on Mounting, 6 Pdr. Mark I—Land Service.

(A.F.O. 5917/43.)
(571/202/1881.)

B.R.1015.—Warship Recognition.

(A.F.O. 5231/44.)
(571/202/2074.)

B.R.1034.—Handbook of Components, Firing Systems and Testing Apparatus, for Independent Non-Conduct Mines—Guard Book.

(A.F.O. 6226/44.)
(571/202/1949.)

B.R.1034 (1).—Hydrostatic Switches.

(A.F.O. 474/45.)
(571/202/1949.)

B.R.1035.—Landing Craft Signal Book.

(A.F.O. 1606/44.)
(571/202/1960.)

B.R.1057.—Handbook for 40-mm. Bofors Gun—Naval Water Cooled Type of British and American Manufacture.

(A.F.O. 4972/44.)
(571/202/2052.)

B.R.1088 (Revised Edition).—Indicating Groups for S.S. Frames.

(511/202/1988.)

B.R.1093.—Guide Book of Maintenance Routines for Coastal Force Craft (Except Diesel Engined Craft).

(A.F.O. 5597/44.)
(571/202/2085.)

B.R.1201/44.—Drill for Admiralty Fire Control Table Marks VI and VI*.

(A.F.O. 6483/44.)
(571/202/2112.)

B.R.1206.—A Review of the Japanese Naval Air Service.

(A.F.O. 6342/44.)
(571/202/2113.)

Abridged Firing Manual. (Late A.C.B. 225.) (Complementary to B.R.987/44.)

(C.B. Circular 195/44.)
(571/202/2012.)

R.A.A.F. Publication No. 513.—Elementary Malay.

(571/201/4572.)

Aircraft Wall Charts, Pacific Series, Issue 1, August, 1944, Sets numbered 1 to 9.

(415/201/1965.)

A.P.1480A.—Amendments, Lists Nos. 110-117, Silhouettes of British Aircraft.

A.P.1480B.—Amendments, Lists Nos. 41-43 and 45, Silhouettes of German Aircraft.

A.P.1480E.—Amendments, Lists Nos. 9 and 10, Silhouettes of Russian Aircraft.

A.P.1480F.—Amendments, Lists Nos. 19-22, Silhouettes of Japanese Aircraft.

A.P.1480I.—Amendments, Lists No. 24, Silhouettes of American Aircraft.

(571/201/4155.)

2. The undermentioned form has been adopted for use in the R.A.N. First supply will be made, without demand, by the Superintending Naval Store Officer, Sydney:—

S.559.—Action Message Form for Damage Control.

(A.F.O. 5827/44.)
(480/202/4685.)

Library
RESTRICTED.(FOR OFFICIAL USE ONLY.)

Commonwealth Navy Orders.

Navy Office, Melbourne,
5th June, 1945.

The following Orders, having been approved, are hereby promulgated for information and guidance, and necessary action.

By direction of the Naval Board,

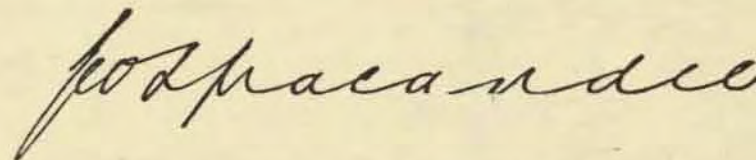

Secretary.

*The Commodore Commanding H.M.A. Squadron,
and Commanding Officers of H.M.A. Ships,
Officers in Charge of H.M.A. Naval
Establishments, and others concerned.*

TABLE OF CONTENTS.

No.	Subject.
226.	Precedence, Rank and Command R.A.N.E. and R.A.N.V.E.
227.	A.M.S. Vessels—Replacement of 20 mm. Oerlikons Mark IIIA by Mark VIIA.
228.	Gunmountings 40 mm. Bofors Mk. IIIA—Modification of Earlier Pattern Pedestals.
229.	Clips Cartridge No. 1 Mark I A.N.—Defective.
230.	Supply of Spectacles for Personnel in the New Guinea Area.
231.	Stawell Prize for 1945.
232.	Conservation of Tires, Tubes and Rubber Goods.
233.	Signals—Indications of Precedence and Their Use.

226.

PRECEDENCE, RANK AND COMMAND R.A.N.R. AND R.A.N.V.R.

As some doubt appears to exist concerning matters of precedence, rank and command between R.A.N.R. and R.A.N.V.R., attention is directed to the provisions of C.O.R. Article 11 as set forth in R.I. 7-8/42.

(428/211/327.)

227.

**A.M.S. VESSELS—REPLACEMENT OF 20 mm. OERLIKONS
MARK III_A BY MARK VII_A.**

It has been decided that, to reduce congestion on the bridges of A.M.S. Vessels, and to improve stability, Mark II_A, III_A or U.S. Mark V Oerlikon mountings on the bridge wings of A.M.S. vessels are to be replaced by Mark VII_A mountings. Where Mark I or U.S. Mark IV mountings are fitted, they are to be retained.

2. Commanding Officers of ships affected are to raise an alteration and addition item, classification "A," to replace existing Oerlikon mountings on bridge wings by Mark VII_A mountings, and to replace the existing bandstands by single step ramps on the inboard sides of the mountings.

3. This item is to be lettered "BV" in accordance with Confidential Commonwealth Navy Order 164 of 1944.

(603/267/1618.)

228.

**GUNMOUNTINGS 40 mm. BOFORS MK. III_A—MODIFICATION OF
EARLIER PATTERN PEDESTALS.**

Defective training has been reported in 40 mm. Bofors mountings fitted with the earlier pattern pedestal.

2. This pedestal can be identified in that the vertical sides are solid, and are not fitted with light metal inspection plates.

3. Training ball races have been found immersed in water, as no drain holes had been drilled through the top of the pedestal to coincide with the drain holes in the base ring of the mounting.

4. All training ball races of mountings fitted earlier pattern pedestals are to be examined as soon as possible, and any defective balls replaced.

5. The tops of the pedestals are to be drilled with sixteen $\frac{1}{2}$ -inch drain holes on a pitch circle of 22.44 inches diameter. Each hole is to be equi-distant between the holes for the bolts securing the mounting to the pedestal.

6. In addition, if not already fitted, a light metal cover plate with a leather washer is to be fitted over the centre hole in the mounting to prevent water entering. Four screwed holes will be found for securing this cover plate, but to facilitate fitting a $\frac{3}{8}$ -in. B.S.F. top should be passed through the holes and $\frac{3}{8}$ -in. B.S.F. screws fitted.

(490/212/1295.)

229.

CLIPS CARTRIDGE No. 1 MARK I A.N.—DEFECTIVE.

With reference to Navy Order 559 of 1944, clips No. 1 Mk. I A.N. manufactured after the date of that Order are correct to design and have been stamped with the date of manufacture.

2. The action called for in paragraph 4 of Navy Order 559 of 1944 is to be limited to clips manufactured by the Crusader Plate Company

(which can be identified by the trade mark ) that do not bear

one or other of the following marks:—

(a) Letter "R"

or

(b) Date of manufacture.

(612/203/3284.)

230.

**SUPPLY OF SPECTACLES FOR PERSONNEL IN THE NEW GUINEA
AREA.**

In future, spectacles for Naval personnel in the New Guinea area are to be obtained from the Ophthalmological Section at the 2nd Medical Receiving Station, Madang. Prescriptions are to be forwarded direct to the Optometrist, 2nd Medical Receiving Station, Group 849, R.A.A.F., Pacific.

2. The procedure laid down in Regulations concerning the supply of spectacles is to be strictly observed. The Naval Officer-in-Charge, New Guinea, is authorized by Navy Order 171 of 1945, paragraph 4, to sign Forms A.M. 250z in all routine cases. When any doubt exists as to the eligibility of any rating for supply, prior approval is to be sought from Navy Office.

3. As inter-Service financial adjustment may be involved in the supply of spectacles from R.A.A.F. facilities, a careful record is to be kept of details of supply from the 2nd Medical Receiving Station, and a monthly return of Forms A.M. 250z, with the cost of spectacles clearly noted upon each, is to be made to Navy Office.

(612/213/2951.)

231.

STAWELL PRIZE FOR 1945.

Details concerning the competition for the Stawell Prize for 1945 are shown hereunder for the information of Naval Medical Officers:—

The Stawell Prize, a memorial to Sir Richard Stawell, is open for competition. The amount of the Prize is £30. The conditions are:—

1. The Prize shall be awarded to the writer of the essay adjudged to be the best on a subject selected annually.
2. The subject for 1945 is *The Clinical and Pathological Features of the Dysenteries*.
3. The dissertation should be based on personal observation and experience of the writer.

4. The competition is open to graduates of any Australian University.
5. The trustees reserve the right to withhold the award.
6. Essays must be delivered to the Medical Secretary, British Medical Association (Victorian Branch), by 4 p.m. on November 30, 1945.
7. Each essay must be typewritten or printed and must not exceed 75,000 words in length.
8. Each essay must be distinguished by a motto and must be accompanied by a sealed envelope marked by the same motto, containing the name and address of the author.
9. The trustees reserve the right to publish the prize essay.

(635/201/1699.)

232.

CONSERVATION OF TIRES, TUBES AND RUBBER GOODS.

The position in regard to the supply of motor tires and tubes is serious. It is imperative that further efforts be made to ensure maximum service from all tires and tubes and attention is again drawn to the precautions to be taken, vide Navy Order 279 of 1943.

2. Where synthetic tires are fitted, special care should be taken to avoid tire heating, the principal causes of which are speeding, overloading and under-inflation. Synthetic tires have as an identifying mark a red spot ($\frac{3}{4}$ inch) on the tire wall.

3. Action should also be taken throughout the Service to conserve rubber goods generally.

(612/259/40.)

233.

SIGNALS—INDICATIONS OF PRECEDENCE AND THEIR USE.

Navy Order 160 of 1945 is to be amended by adding the following note under table of Precedences:—

NOTE.—When preparing messages for transmission, the operating signal QPE is to be inserted in the Message instructions (D.N.C.5 Article 6263) and not in the form as indicated in the "Symbol" column above.

(2037/2/1352.)

By Authority: H. E. Daw, Government Printer, Melbourne.

RESTRICTED.

(FOR OFFICIAL USE ONLY.)

Commonwealth Navy Order.

Navy Office, Melbourne,

5th June, 1945.

The following Order, having been approved, is hereby promulgated for information and guidance and necessary action.

By direction of the Naval Board,

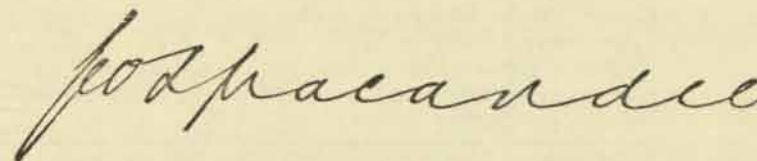

Secretary.

*The Commodore Commanding H.M.A. Squadron,
and Commanding Officers of H.M.A. Ships,
Officers in Charge of H.M.A. Naval
Establishments, and others concerned.*

TABLE OF CONTENTS.

No.	Subject.
234.	Issue of Mess Gear and Blankets to Naval Personnel Travelling.
	C.5255/45.

234.

ISSUE OF MESS GEAR AND BLANKETS TO NAVAL PERSONNEL TRAVELLING.

The following are the approved arrangements for the issue of mess gear to personnel travelling by troop train and road transport throughout the Commonwealth:—

- (a) *Between Melbourne, Sydney and Brisbane.*—It is not necessary for loan issues to be made to personnel travelling between these points.
- (b) *On Other Routes.*—Personnel are required to be in possession of mess gear when travelling—
- (i) between Adelaide and Perth by troop train;
 - (ii) between Adelaide and Darwin by troop train and road transport;
 - (iii) between Melbourne and Adelaide by troop train;
 - (iv) north of Brisbane by troop train; and
 - (v) between Townsville and Darwin by troop train and road transport.

2. Arrangements have been made with the New South Wales Railways Department to issue cutlery to Naval personnel travelling by rail in that State. To ensure that issues are properly accounted for, the following instructions are to be incorporated in orders issued by the Railway Transport Officers at Sydney, Melbourne and Brisbane to officers or ratings in charge of drafts travelling between Melbourne, Sydney and Brisbane:—

Issue of Mess Gear.—On arrival at troop train feeding points between Melbourne and Brisbane, the officer or rating in charge of draft is to carry out the following procedure:—

- (i) Report to the manager of the railway refreshment room for issue of the required number of knives, forks and spoons, give attached receipt to the manager of the railway refreshment room and issue articles to personnel. Where necessary, collection and distribution may be arranged through a number of suitable ratings, personnel being warned to guard against losses by non-return.
- (ii) Arrange for collection of cutlery on completion of the meal and obtain a receipt from the manager of the railway refreshment room for delivery to the Railway Transport Officer at next capital city.
- (iii) Any shortages to be immediately investigated and instructions issued to the ratings responsible for the loss to report to the Railway Transport Officer at the next capital city immediately on arrival. If personnel responsible cannot be determined, the value of cutlery (knife 2s. 2d., fork 1s., spoon 10d.) is to be collected from the draft in equal shares and remitted to the Railway Transport Officer.

3. Requests for the supply of mess gear, as per the following *pro forma* at (a), are to be made at each refreshment room, separate

receipts for return being obtained, as in *pro forma* (b), from the manager of each refreshment room at which meals are supplied:—

(a) The Manager,

R.R.R.

Please supply to Naval personnel.....
knives..... forks..... spoons for
use at meal on.....

Delivery of these articles, which will be returned on completion of meal, is hereby acknowledged.

.....
O.C.R.A.N. Draft.

(b) It is certified that cutlery issued to Naval personnel for meal on.....has been returned, with the exception of the following—

Short returned.

Knives
Forks
Spoons

(NOTE.—Delete italicized portion as necessary.)

.....
Manager, R.R.R.

Date.....

4. The issue and collection of mess gear at Melbourne, Perth, Brisbane, Adelaide and Townsville will be made by the respective Railway Transport Officers. At Darwin and Cairns the respective Naval Officers-in-Charge will make necessary local arrangements.

5. The issue of mess gear to personnel departing from Melbourne for Adelaide, Perth or Darwin (via Adelaide) by troop train, and its collection from personnel arriving in Melbourne, via Adelaide, is normally the responsibility of the Railway Transport Officer at Melbourne. Personnel proceeding from Fremantle to Townsville, via Brisbane, will be issued with mess gear at Perth which is to be handed in on arrival at Melbourne and a further issue made at Brisbane before departure for Townsville.

6. Personnel, other than those referred to in paragraph 7, travelling to destinations in South Australia and Western Australia by means of special trains departing from Flinders Naval Depot during leave periods are, however, to be issued on loan with mess gear, blankets and water bottles, as necessary, at Flinders Naval Depot prior to departure. Items issued in this manner are to be retained by the personnel concerned whilst on leave and are to be collected at Flinders Naval Depot on their return.

7. Personnel on "Draft" or "Leave and Draft" who travel on these special trains from Flinders Naval Depot, are, on arrival at Melbourne, to be issued with loan gear by the Railway Transport Officer at Spencer-street Station, to whom a nominal list of personnel concerned is to be forwarded by Flinders Naval Depot at least 24 hours before the time of departure of the train from Melbourne.

8. The Railway Transport Officer at Brisbane is to issue mess gear to personnel travelling northward from Brisbane by troop train, and is to collect such gear from personnel arriving at Brisbane by troop train from Townsville, Cairns or Darwin, irrespective of their final destination.

9. Form A.T. 801z (in triplicate) is to be utilized for the purpose of recording details of all issues made by Railway Transport Officers, provision being made therein for the signature of each member of the draft so supplied. This form is now being revised and first supplies will be distributed without demand, when available.

10. Where drafts for more than one destination are travelling on the same train, separate Forms A.T. 801z are to be prepared by the responsible Railway Transport Officer for each draft. The original and duplicate copies are to be given to the officer or senior rating in charge of the draft, for delivery to the Railway Transport Officer responsible for the collection of the gear, with necessary instructions to ensure that the forms are handed to the Railway Transport Officer immediately on arrival at the point where the gear is to be collected. The triplicate copy is to be retained by the issuing Railway Transport Officer.

11. The receiving Railway Transport Officer is to check all items handed in against issues recorded on Form A.T. 801z, receipt the duplicate copy and return it to the issuing Railway Transport Officer. All cases of failure to return gear are to be promptly investigated, and any discrepancies noted on the back of the form in accordance with the printed instructions shown at the foot of the duplicate copy.

12. In cases where personnel are diverted to a destination other than that originally intended, or where personnel travel to an intermediate station at which a Naval Railway Transport Officer is not established, the following procedure is to be followed:—

(i) *Diverted Personnel.*—The Railway Transport Officer at the point where the diversion occurs is to obtain, from the officer or rating in charge of the draft, Form A.T. 801z prepared by the issuing Railway Transport Officer, amending it as necessary in respect of the personnel diverted and notifying the issuing Railway Transport Officer accordingly. A new Form A.T. 801z is then to be prepared in respect of the gear held by personnel diverted and forwarded to their ultimate destination. For example, where a portion of a draft travelling from Melbourne to Fremantle is diverted to Darwin after arrival at Adelaide, the Railway Transport Officer at Adelaide is to amend Form A.T. 801z prepared by Railway Transport Officer, Melbourne, by endorsing both copies with a note that the personnel have been diverted. The new form is to be forwarded to Naval Officer-in-Charge, Darwin, and Railway Transport Officer, Melbourne, informed accordingly.

(ii) *Personnel Travelling to Intermediate Stations.*—When issuing gear to personnel travelling on leave to intermediate stations, e.g., Kalgoorlie, such personnel are not

to be included in Form A.T. 801z. They are to sign separate receipts for the articles issued and are to be instructed to retain such gear whilst on leave, surrendering it to the issuing Railway Transport Officer on their return.

13. The cash value of any mess gear and blankets issued on loan to personnel travelling and subsequently lost by neglect is, when practicable, to be recovered from the personnel responsible by the Railway Transport Officer to whom, and at the time, the draft reports on completion of their journey. Where responsibility for loss cannot be directly attributed to any particular member of the draft, the total value of the articles lost is to be apportioned equally amongst all personnel concerned and recovery effected direct from each person whenever possible.

14. The Railway Transport Officer is to issue an official receipt for all amounts collected by him. Where an amount represents value of deficient mess gear apportioned amongst a number, the receipt is to be issued to the member in charge of the draft.

15. All moneys so collected are to be paid over by the Railway Transport Officer on the day of receipt, or at the first opportunity subsequently, to the Accountant Officer of the nearest Naval Establishment, accompanied by a list showing details of the articles lost, their value and, in the case of deficient mess gear the total number of persons from whom value has been recovered.

16. The Railway Transport Officers at Melbourne and Brisbane are to forward, for the information of the Railway Transport Officer, Sydney, a copy of any similar list relating to recoveries at their centres in respect of mess gear lost between Melbourne, Sydney and Brisbane.

17. Where recovery of the cash value of losses is impracticable, losses are to be dealt with on Form A.S. 126—Stores lost by Neglect—which is to be prepared in quadruplicate by the receiving Railway Transport Officer. Three copies are to be forwarded to the Accountant Officer of the ship or establishment to which the officer or rating is appointed or drafted, and the quadruplicate copy retained. In the case of losses of mess gear by personnel travelling between Melbourne, Sydney and Brisbane, an additional copy of Form A.S. 126 is to be prepared and forwarded to the Railway Transport Officer, Sydney, for information.

18. The rates to be charged for mess gear, blankets and water bottles lost by neglect are:—

	s.	d.
Knives, table	2	2 each.
Forks, table	1	0 each.
Spoons, dessert	0	10 each.
Pannikins, tin	0	8 each.
Plates, tin	0	6 each.
Blankets, loan	17	4 each.
Bottles, water	3	10 each.

Any variation in these rates will be promulgated in Navy Orders from time to time.

19. Each Railway Transport Officer is to maintain a record of issues and receipts of loan gear, which is to be forwarded monthly to the Accountant Officer of the Establishment to which he is attached.

20. Loan blankets are to be issued by Railway Transport Officers to all Naval personnel desiring same for use during any interstate rail journey. Such issue is compulsory in all cases where personnel travel by troop train and road transport on the following routes:—

- (a) Between Townsville and Darwin (via Mount Isa);
- (b) Between Adelaide and Darwin (via Alice Springs); and
- (c) Between Adelaide and Perth.

21. The issue of blankets is to be made in accordance with the general procedure applicable to loan issues of mess gear.

22. The issue of water bottles by Railway Transport Officers is to be confined to personnel travelling on leave by troop train and road transport on the routes specified in paragraph 20 above. Webbing gear is not to be included in issues of water bottles made by Railway Transport Officers.

23. The issue of water bottles to personnel on draft is to be made by the drafting depot or ship in accordance with Navy Order 296 of 1940, as amended by Navy Order 84 of 1942. Instructions in regard to accounting for these issues are contained in Navy Order 246 of 1942.

24. Navy Orders 170, 264, 552, and 627 of 1944 are hereby cancelled.

(530/201/575.)

RESTRICTED.

(FOR OFFICIAL USE ONLY.)

Commonwealth Navy Orders.

Navy Office, Melbourne,

12th June, 1945.

The following Orders, having been approved, are hereby promulgated for information and guidance, and necessary action.

By direction of the Naval Board,

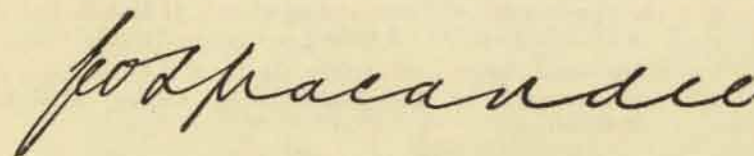

Secretary.

*The Commodore Commanding H.M.A. Squadron,
and Commanding Officers of H.M.A. Ships,
Officers in Charge of H.M.A. Naval
Establishments, and others concerned.*

TABLE OF CONTENTS.

No.	Subject.
235.	Darwin Naval Base Organization.
236.	Reporting of Movements of Personnel.
237.	Badges for War Service.
238.	Disposal of Restricted, Repairable or Unserviceable Ammunition.
239.	Landing of Hedgehog Projectiles.
240.	Supply of Clothing to Civilian Crew of R.A.F.A. "Kurumba."

235.

DARWIN NAVAL BASE ORGANIZATION.

The following is the organization of the Darwin Naval Base:—

- (a) All local defence and auxiliary vessels based on Darwin excepting boom vessels and A.M.S. vessels, are tenders to H.M.A.S. *Melville* for the following purposes:—

Discipline.
Pay.
Personnel.
Victualling.
Naval Stores.

With the exception of the boom vessels, all are under the operational control of the Naval Officer-in-Charge, Darwin, who will also deal direct with these vessels respecting engineering, gunnery, electrical, W/T and similar matters. Correspondence on these subjects should be addressed to the Naval Officer-in-Charge, and, in the case of local defence vessels, a copy should be forwarded to *Melville* for information.

- (b) A.M.S. Vessels based at Darwin are independent commands with pay and victualling accounts carried out in *Melville*.
(c) The Boom defence depot together with boom working vessels and boom gate vessels is a separate entity under the command of the Boom Defence Officer. Pay and victualling accounts are carried in H.M.A.S. *Melville*.
(d) The appointment of Commanding Officer, H.M.A.S. *Melville* is distinct from Naval Officer-in-Charge, Darwin.
(e) Shore establishments other than the boom defence depot are administered by the Commanding Officer, H.M.A.S. *Melville*.

2. Confidential Commonwealth Navy Order 112 of 1943 and Navy Order 197 of 1943 are hereby cancelled.

(1937/2/171.)

236.

REPORTING OF MOVEMENTS OF PERSONNEL.

Instances are still coming under notice of failure by H.M.A. ships and establishments to comply with the instructions contained in Navy Orders 156 of 1941 and 257 of 1942 as amended by Navy Order 201 of 1943 regarding the reporting of movements of personnel.

2. Up-to-date records of the whereabouts of all personnel are essential not only for drafting and general administrative purposes but also for the prompt re-direction of private mail for personnel and attention to inquiries from next of kin, &c. Failure to report all such movements as they occur also result in considerable unnecessary investigation, and avoidable delays.

3. The standing instructions in this connexion are consolidated hereunder for information and guidance of all Commanding Officers, who are to take all steps necessary to ensure strict compliance therewith.

4. *H.M.A. Ships and Establishments in Combat Areas.*—(a) *Signals.*—All entries in and discharges from H.M.A. ships and establishments in combat areas are to be reported by signal addressed to the Naval Board and repeated to the Naval Officer-in-Charge, Flinders Naval Depot, as soon as possible after the movement has taken place. Subject only to the requirements of W/T silence, such signals which should contain the following information should be despatched on the date of the movement:—

- (i) Movement Signal No. (Consecutive No.)—See footnote.
- (ii) Surname and initials and category (e.g., R.A.N., R.A.N.R., &c.), of officers.
- (iii) Official numbers of petty officers and men. These should be repeated separately in all cases, e.g., 23894 (R) 23894, P.A.3912 (R) P.A.3912, S.4597 (R) S.4597 and *Not* in groups, e.g., *Not* 23894, P.A.3912, S.4597 (R) 23894, P.A.3912, S.4597.
- (iv) Particulars of movement, i.e., from or to as the case may be, permanent movements being indicated by (A) and temporary movements by (B).

Where discharge to ultimate destination is made *via* a ship or establishment or by passenger ship, the full movement should be shown, e.g., To "Penguin" for "Swan."

NOTE.—As regards (i)—except in ships and establishments in which this is already being shown the signal is to contain the preamble Movements Signal No. (...).

(b) *Form A.S. 165.*—All entries and discharges are also to be prepared daily as the movements occur and despatched as under by first air mail.

- (i) Original to Director of Navy Accounts (Personnel Movements), Navy Office, Melbourne.
- (ii) Two copies to the Naval Officer-in-Charge, Flinders Naval Depot. The remaining copy of the return is to be retained in the ship or establishment, but in the case of H.M.A. ships whose pay accounts are kept elsewhere, a carbon copy of the return is to be prepared and despatched to the ship or establishment in which the accounts are kept.

5. *H.M.A. Establishments in Australia and Tenders Thereto.*—All movements of personnel to or from H.M.A. establishments in Australia or tenders thereto are to be reported on Form A.S.165 on the day on which the movement occurs, original copy being forwarded to the Director of Navy Accounts (Personnel Movements), Navy Office, Melbourne, and two copies to the Naval Officer-in-Charge, Flinders Naval Depot.

In the case of tenders in which Forms A.S.165 are rendered direct, a carbon copy of the form should be sent to the parent ship.

Where such tenders proceed temporarily to a combat area or in any case in which report by Form A.S.165 is not immediately practicable, the movements are to be reported by signal addressed to the Naval Board and repeated to the Naval Officer-in-Charge, Flinders Naval Depot, and Form A.S.165 forwarded by first air mail thereafter.

6. *Nominal Lists of Personnel.*—In the case of H.M.A. ships which are transferred for operational purposes from a base in Australia to a base in a combat area, a nominal list of personnel borne at the date of transfer is to be prepared in triplicate, the copies being despatched by first air mail as under:—

Original to Director of Navy Accounts (Personnel Movements), Navy Office, Melbourne.

One copy each to the Naval Officer-in-Charge, Flinders Naval Depot, and the Naval Officer-in-Charge of the ship or establishment in which the pay accounts are kept.

7. *General.*—Naval Officers-in-Charge will be responsible that records of personnel movements maintained locally are kept in such a manner as to permit of prompt and accurate advice to Navy Office—should occasion arise—of the whereabouts of all personnel serving under their administrative control (including those borne in vessels whose accounts are carried in the establishment). The importance of the strict observance of this procedure cannot be too strongly impressed upon the officers responsible for the keeping of such records.

The greatest care is to be taken to ensure that Forms A.S.165 are forwarded daily as movements occur, and that the information furnished therein is complete and correct in every particular. All movements of officers are to be included in Forms A.S.165. Incorrect spelling of names and incorrect initials in these returns entail unnecessary work in Navy Office and in Flinders Naval Depot, and can easily have far-reaching effects. It is important that official numbers be shown but in any case in which same are not known the full Christian names of the members concerned are to be shown in the return.

As the general purpose of Forms A.S.165 is to enable up-to-date records to be maintained both in Navy Office and in Flinders Naval Depot of the actual whereabouts of personnel (irrespective of where their pay accounts are kept), all movements of personnel from one ship or establishment to another for victuals only are to be included in such returns.

It is essential that all movements of personnel of H.M.A. ships occurring on the day of departure from port (including absentees on sailing) be communicated by signal and/or Form A.S.165, as appropriate, on that day, arrangements being made as necessary with the Naval Authorities at the port for transmission of the message.

In regard to personnel discharged to leave, the following general principles are to apply:—

Personnel due to rejoin ship at same port on completion of leave.
—Signal and/or Form A.S.165 necessary only if personnel fail to rejoin ship.

Personnel to rejoin ship at another port on completion of leave.—Signal and/or Form A.S.165 to be rendered showing discharged days' leave and further signal and/or Form A.S.165 on return of member to ship.

Personnel to join another ship or an establishment on completion of leave.—Signal and/or Form A.S.165 to be rendered showing discharged to days' leave and to (name of ship or establishment to which transferred). Completion of movement to be communicated by signal and/or Form A.S.165 by ship or establishment to which personnel transferred.

8. In all cases of doubt, the consideration to be borne in mind is the possibility of casualties and the consequent necessity for complete information of the actual whereabouts of personnel being available in Navy Office at the shortest notice.

(502/201/713.)

237.

BADGES FOR WAR SERVICE.

The Commonwealth Government have decided that Official Badges relative to service in the Royal Australian Navy during the present war shall be issued as follows:—

- (a) Returned from Active Service Badge.
- (b) General Service Badge.
- (c) Exemption Badge (Medically Unfit).
- (d) Exemption Badge (Reserved Occupation).
- (e) Female Relative's Badge.
- (f) Mother's and Widow's Badge.

2. Conditions under which the above-mentioned badges are to be issued are as set out below:—

(a) *Returned from Active Service Badge.*

This badge will be issued to all officers and men of the R.A.N., R.A.F.R., R.A.N.R.(S.), R.A.N.R., and R.A.N.V.R., and to members of the Women's Royal Australian Naval Service, and Royal Australian Naval Nursing Service, also to members of the Mercantile Marine who serve under a T.124 Agreement, and Canteen Staffs, who were mobilized and have rendered appropriate service in a ship of war at sea for a period of at least 28 days since the commencement of hostilities, or have served in a sphere of war operations. This is subject to the reservation that eligibility for the badge will accrue irrespective of the period of service in the event of engagement in actual warlike operations against the enemy. Service ashore in the following areas will qualify for the badge:—

Northern Territory, north of parallel 14.5° South*—from 19th February, 1942.

(* This includes the Darwin area.)

Mandated New Guinea—from 4th January, 1942.

Papua—from 2nd February, 1942.

Torres Strait Islands—from 19th March, 1942.

The badge will only be issued to personnel eligible for the award who have been discharged from the Service since the commencement of hostilities. The badge will not be issued until the termination of hostilities to the other eligible personnel who are still serving.

These badges are not to be worn by personnel when in uniform.

Persons Ineligible—

Personnel who desert or who are dismissed, or discharged for disciplinary reasons will not be eligible to receive the badge.

(b) General Service Badge.

Persons Eligible—

(i) Members of the R.A.F.R., R.A.N.R.(S.), R.A.N.R., R.A.N.V.R., and Officers on the Retired or Emergency Lists of the Royal Australian Navy who have not yet been mobilized.

(ii) Members of the R.A.F.R., R.A.N.R.(S.), R.A.N.R., R.A.N.V.R., and Officers on the Retired or Emergency Lists of the Royal Australian Navy who have been demobilized and who are not eligible for the award of "the Returned from Active Service" Badge, except in the case of members demobilized because they are in Reserved Occupations. Such personnel will receive the "Exemption" Badge (Reserved Occupation).

(iii) All Officers and men of the R.A.N., R.A.F.R., R.A.N.R.(S.), R.A.N.R., and R.A.N.V.R., who have been discharged "Below Naval Physical Standard" or "Physically Unfit for Naval Service" (not due to misconduct) and who are not eligible for the award of "the Returned from Active Service" Badge.

(c) Exemption Badge (Medically Unfit).

In view of the fact that medical rejection for the Navy does not necessarily mean that a volunteer is permanently medically unfit for the A.I.F. or other War Service, the issue of this badge will be under the sole control of the Army, and volunteers rejected as medically unfit by the Navy would have to be certified as medically unfit for the A.I.F., and Air Force also, before becoming entitled to receive the "Exemption" Badge (Medically Unfit). The badge will not be issued to persons with manifest disease or deformity.

(d) Exemption Badge (Reserved Occupation).

This badge will be issued by the Service in which the volunteer wishes to enlist upon presentation by him of a Certificate from the Man-power Authorities indicating that he is in a reserved occupation. The badge will only be issued to persons who volunteer, unconditionally, to serve overseas with any service, when called upon at any time during the war, who are medically fit for service and who are in all respects eligible for enlistment or appointment.

(e) Female Relative's Badge.

(i) This badge will be issued to the wife and/or mother or to the nearest female relative of any member who is now entitled or will become entitled to a "Returned from Active Service" Badge.

(ii) Badges issued on account of one member on service will have one star attached. Badges issued to mothers will have additional stars attached for each additional child on service, the wife of a member on service receiving a star on account of her husband as well as a star on account of each child on service. One badge only will be issued to the one female relative.

(iii) If a member be married or a widower, the badge will be issued to the nearest female relative in accordance with the following degrees of relationship:—

1st—If a member be married, the badge will be issued to his wife. The mother of a married member may also receive a badge on his account; or

2nd—If a member be a widower, the badge will be issuable to the eldest daughter living. The mother of a widower may also receive a badge on his account; or

3rd—If a member be a widower without a mother or daughter his eldest sister may receive the badge.

(iv) If a member other than a widower be unmarried, the degrees of relationship will be as follows:—

1st—Mother; 2nd—Eldest sister.

Where there are twin sisters the badge will be issued to the elder twin sister.

(v) In the event of a member not having any female relative as described above, it will be necessary for him to nominate in writing the nearest blood relation.

(vi) Female guardians of legally adopted children will be eligible to receive the badge.

Application for this badge should be made direct, by the wife or mother or nearest eligible female relative, to the Secretary to the Naval Board, Navy Office, Melbourne.

(f) Mother's and Widow's Badge.

This badge will be issued to the mother and/or widow of a member of the Naval Forces killed in action or died of wounds or from other causes whilst on service or as a result of such service.

Stars will be attached to the badges as under:—

Widow of a deceased member	1 star
Mother of one deceased member	1 star
Mother of two deceased members	2 stars
Mother of three deceased members	3 stars
Mother of four deceased members	4 stars
Mother of five deceased members	5 stars

A widow of a deceased member who is also a mother of a deceased member or members will receive one badge only with a star on account of each deceased son as well as a star on account of the deceased husband.

Female guardians of legally adopted children will be eligible to receive the badge.

Application for this badge should be made direct by the mother or widow to the Secretary to the Naval Board, Navy Office, Melbourne.

3. *Replacement of Badges.*—Badges lost or destroyed will not normally be replaced. Departures from this principle will be permitted only in very exceptional circumstances.

4. *Issue of Badges.*—Badges will be numbered in sequence and, with the exception of the "Exemption" Badge (Medically Unfit), will be issued by Navy Office.

The following badges will be issued on loan and will be returned in the following circumstances:—

Returned from Active Service Badge.—On a member being re-engaged for further service.

General Service Badge.—On a member being mobilized.

Exemption Badges (Medically Unfit).—On a person being passed as medically fit for engagement in the Navy, Army or Air Force.

(Reserved Occupation).—On a person being permitted to engage for Naval Service.

5. The issue of the following badges has been suspended since September, 1942:—

General Service Badge.

Exemption Badge (Medically Unfit).

Exemption Badge (Reserved Occupation).

6. Navy Orders Nos. 280 of 1940 and 313 of 1942 are hereby cancelled.

(416/201/764.)

238.

DISPOSAL OF RESTRICTED, REPAIRABLE OR UNSERVICEABLE AMMUNITION.

Naval Officers-in-Charge of outports are reminded that quantities of restricted, repairable or unserviceable ammunition should not be allowed to accumulate. Quantities of such ammunition held should be reported to Navy Office from time to time for disposal instructions.

2. In the case of small quantities of unserviceable ammunition in a dangerous or doubtful condition, or for which suitable isolated storage is not available, the ammunition may be dumped or destroyed forthwith. A report of the action taken is to be forwarded to Navy Office for covering approval. When large quantities are concerned, instructions should be sought before disposal, if necessary by signal, particulars of the state of the ammunition being furnished.

(408/201/2378.)

239.

LANDING OF HEDGEHOG PROJECTILES.

In future, H.M.A. Ships are to observe the following procedure when it is desired to land hedgehog projectiles:—

(a) The local Armament Supply Officer is to be notified by signal.

(b) The signal is to confirm that:—

(i) fuses are safe for handling;

(ii) that Naval Magazine and Explosives Regulations, Article 48, have been complied with.

(c) Particulars of defects found are to be clearly marked on boxes.

(d) Wetted rounds are to have date of wetting clearly marked on packages.

(471/209/1457.)

240.

SUPPLY OF CLOTHING TO CIVILIAN CREW OF R.A.F.A. "KURUMBA."

The Master of R.A.F. *Kurumba* is authorized to purchase, as necessary, from any H.M.A. ship in which a supply officer is borne, or from a R.A.N. Victualling Store Issuing Ship, immediate requirements of khaki shirts, khaki shorts, khaki trousers, black leather boots and black leather shoes in order to meet the needs of members of the crew during their service in *Kurumba* whilst absent from Australia.

2. To enable the Master to obtain such requirements, members of the crew are to tender the value of their individual requirements to the Master, together with completed Form A.S.80 for transmission to the supply officer concerned. A supply of Forms A.S.80 is to be maintained for the purpose in *Kurumba*. The Master is to keep a record of the issues made to each individual and forward a copy thereof quarterly to the Director of Victualling.

3. The value of the clothing is to be assessed at the prices shown in the current issue of the "Official Memorandum—Prices of clothing maintained for issue on repayment to Ships' Companies," and the Master is to ensure that any supplies made are restricted to immediate requirements on all occasions.

(434/201/3742.)

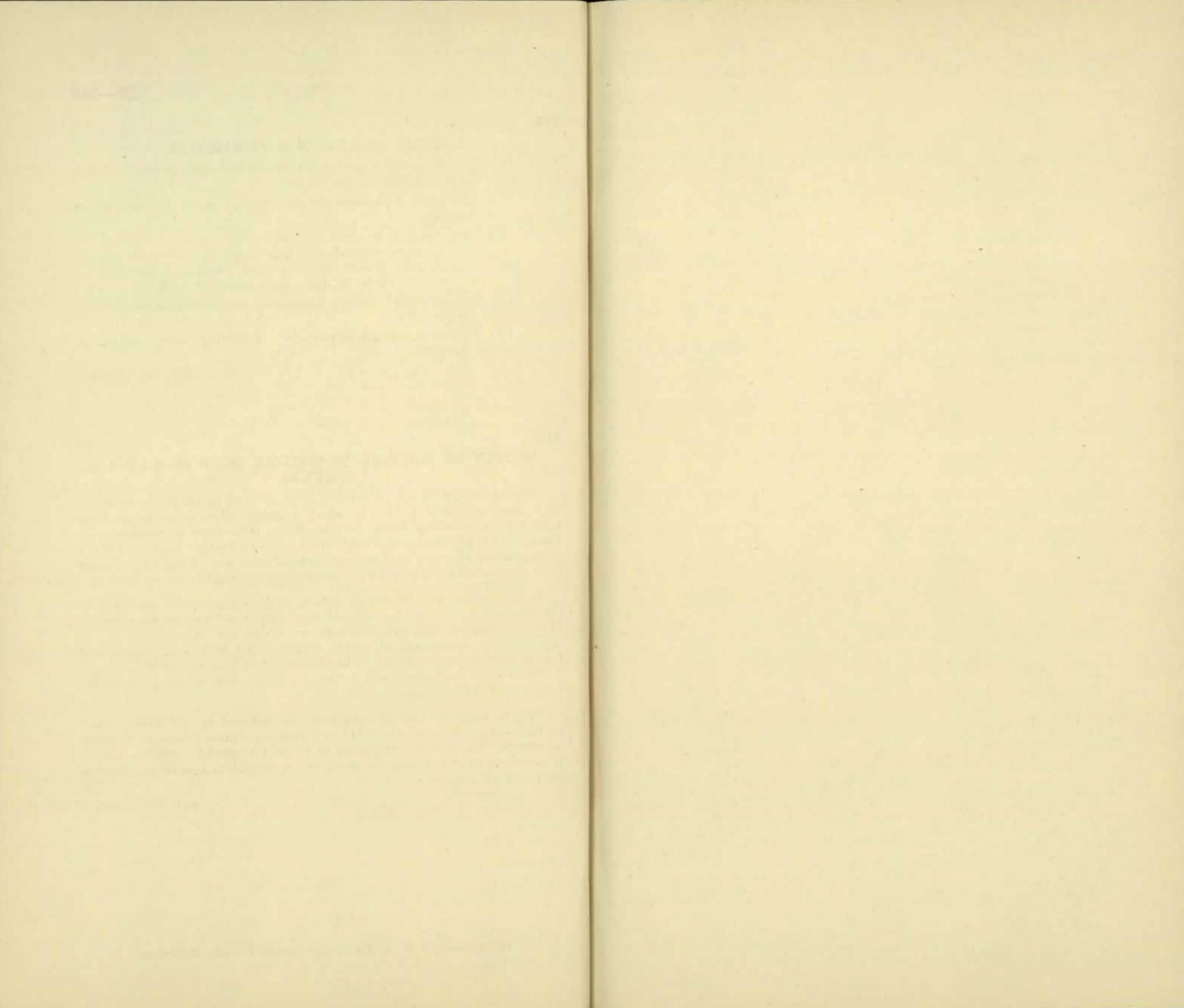

RESTRICTED.

(FOR OFFICIAL USE ONLY.)

Commonwealth Navy Order.

Navy Office, Melbourne,
19th June, 1945.

The following Order, having been approved, is hereby promulgated for information and guidance and necessary action.

By direction of the Naval Board,

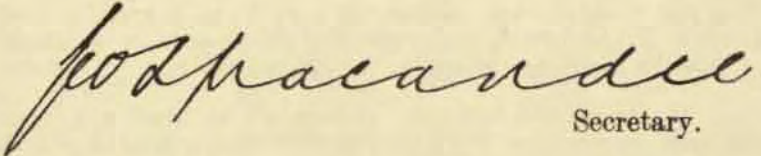
Secretary.

*The Commodore Commanding H.M.A. Squadron,
and Commanding Officers of H.M.A. Ships,
Officers in Charge of H.M.A. Naval
Establishments, and others concerned.*

TABLE OF CONTENTS.

No.	Subject.
241.	Professional Examinations for Advancement to Petty Officer and Leading Seamen.

C,5739/45,

241.

PROFESSIONAL EXAMINATIONS FOR ADVANCEMENT TO PETTY OFFICER AND LEADING SEAMEN.

The examinations are to be conducted by examination boards consisting of officers appointed by flag officers commanding squadrons (or senior officers present). The composition of the boards and the method of conducting the examinations rests with the convening authority, who shall decide on the number of officers who are to comprise a board and whether more than one board will be required.

Normally, the minimum examination board, which should include an officer from the candidate's ship whenever possible, should be composed of—

- 1 Commander (as President),
- 1 Navigating Officer,
- 2 Lieutenant-Commanders or Lieutenants,
- 1 Boatswain,

but occasions may arise on outlying stations when it may not be possible for a board so constituted to be assembled. Subject to local conditions, the maximum number of candidates examined by one board should be eight. Professional examinations for leading seaman may be carried out by ship or flotilla boards, instead of by squadron boards.

2. Whenever possible, examination boards are to be composed of officers serving in sea-going ships, and are to be conducted in ships where all facilities for carrying out these examinations are available. Flag and senior officers ordering the assembly of boards for candidates in shore establishments and stationary ships, at home or abroad, are to take the necessary steps to ensure this procedure.

3. In certain circumstances, it may not be possible to convene a squadron examination board, as detailed above, until a considerable time has elapsed since the date on which a candidate's application for examination was forwarded by his commanding officer; should this period exceed three months, he is to be examined by the officers of his own ship in lieu of a squadron board.

Under war conditions, full use should be made of this provision, and the period of three months laid down may be reduced as necessary at the discretion of flag and commanding officers.

Squadron boards should, as far as practicable, be strictly squadron or flotilla boards, submarine candidates when possible being examined by the latter.

4. Squadron boards should be assembled at intervals, normally, of not less than once a quarter, but more often should exigencies, such as the meeting of ships and drafting changes, prove this to be desirable.

5. Normally, the president of a board should not be required to examine candidates in a particular subject. He may, however, do so if he wishes, particularly when any doubt arises as to the suitability of a candidate.

6. Examinations are to be oral and practical. The syllabuses are as follows:—

SYLLABUS FOR EXAMINATION OF LEADING SEAMAN FOR PETTY OFFICER.

SECTION I.—ABILITY TO TAKE CHARGE.

General.

- (a) To take charge of a class in—
 - (i) Squad drill.
 - (ii) Physical and recreational training.
- (b) To tell off a party of men for work of the following nature and carry it out:—
 - (i) Getting out kedge anchors.
 - (ii) Working derricks.
 - (iii) Handling awnings.

SECTION II.—TECHNICAL ABILITY.

Rigging.—Ability to instruct in, and demonstrate practically, any of the following:—

- (a) All knots, splices, bends, hitches, and other practical rigging normally taught to seamen, *vide* Chapter 3 of Seamanship Manual, Volume I.

NOTE.—President to set test job in hemp and wire, and candidates to be examined in practical rigging at the examination.
- (b) (i) Types and uses of all hawsers.
 - (ii) How to calculate working and breaking strains of hawsers.
 - (iii) Different types of tackles, their uses, and how to fit them.
 - (iv) Boats' falls and fittings, fitting and reeving, and securing. All fittings on davits.
 - (v) Care and maintenance of all hawsers and blocks.
- (c) Rigging sheers and derricks. To be done practically—with spars (small) in particular—
 - (1) Head lashing.
 - (2) Passing strop.
 - (3) Splay and heel tackles.
 - (4) Lead of topping lift.

N.B.—Knowledge of holdfasts on shore not necessary.

- (d) Target work. To be confined to a general knowledge of towing arrangements, and setting and furling sails.
- (e) Thorough knowledge of standing and running rigging, as generally fitted in His Majesty's ships.
- (f) Repair of canvas gear and elementary sailmaking.

Boat Work.

- (a) Handling of boats under power, sails, and oars.
- (b) Ability to instruct a crew of inexperienced ratings under oars and sail.

- (c) Hoisting, lowering and securing a seaboat.
- (d) Knowledge of boats' falls, fittings and gear, and duties of coxswain.
- (e) Practical knowledge of temporary repairs by boat's crew to boat's hull, mast and fittings.

NOTE.—Where it is found impracticable to carry out the examination in boatwork, commanding officers are to certify on Forms A.S.441 that the candidates are proficient in this subject.

General Duties.

- (a) To be able to steer a ship and instruct men in the duties of helmsman and telegraphman.
- (b) Sufficient knowledge of compass, chart reading, laying off courses, and uniform system of buoyage; to undertake quartermaster's duties and coxswain of drifter and picket boat.
- (c) Practical knowledge of methods of sounding and taking charge of a sounding party.
- (d) Writing up log-book. Reading a barometer.
- (e) To be able to use a boatswain's call for calls in normal daily use.

Rule of the Road.—Practical knowledge of the regulations for preventing collisions at sea.

Anchor Work.

- (a) A practical working knowledge of working anchors, cables and capstans under all circumstances.
- (b) A practical knowledge of laying out anchors; weighing anchors from a boat.
- (c) All forms of forecastle work, including "bringing to" and tending wires.
- (d) Duties when in charge of an anchor watch.

Watertight Fittings.—Practical knowledge of—

- (a) Operating of W.T. doors and valves, and their application to fire and collision.
- (b) Elementary shoring and its uses.

NOTE.—This examination should be carried out by an executive officer.

Organization.

- (a) To describe any evolution carried out in candidate's ship, including a general knowledge of paravanes, where fitted.
- (b) General duties of a petty officer, e.g.—
 - (1) Captain of a top.
 - (2) Petty officer of day.
 - (3) Regulating, &c.

Signals.

- (a) To be able to interpret any signals in the Boats' Signal Book with the aid of the book.
- (b) Sufficient knowledge of semaphore and morse lamp to make and read a message at a slow rate (four words per minute).

SYLLABUS FOR EXAMINATION OF ABLE SEAMAN FOR LEADING SEAMAN.

SECTION I.—ABILITY TO TAKE CHARGE.

General.

- (a) To take charge of a class in—
 - (i) Squad drill.
 - (ii) Physical and recreational training.
- (b) To tell off a party of men for work of the following nature and carry it out:—
 - (i) Working small derricks.
 - (ii) Handling awnings.

SECTION II.—TECHNICAL ABILITY.

Rigging.—Thorough knowledge and practical work in—

- (a) Rigging, including splicing in hemp and wire, e.g., 3½-in. wire—
 - (i) Thimble eye.
 - (ii) Hawser eye.
 - (iii) Strop a 10-in. block with a strand of 3½-in. wire, 3½-in. (or larger) white hemp—
 - (i) Becket.
 - (ii) Long splice.
 - (iii) Cut splice.
- (b)
 - (i) Types and uses of all hawsers.
 - (ii) How to calculate working and breaking strains.
 - (iii) Different kinds of tackles, their uses and how to fit them.
 - (iv) Boats' falls and fittings. Fitting, reeving and securing all fittings on davits.
 - (v) Care and maintenance of all hawsers and blocks.
- (c) Rigging sheers and derricks (must be done practically with spars (small).
 - In particular—
 - (i) Head lashing.
 - (ii) Passing strop.
 - (iii) Splay and heel tackles.
 - (iv) Lead of topping lift.

N.B.—Knowledge of holdfasts on shore not necessary.

- (d) Target work. To be confined to a general knowledge of towing arrangements and setting and furling sails.
- (e) Thorough knowledge of standing and running rigging as generally fitted in His Majesty's ships.
- (f) Repair of canvas gear and elementary sail making.

Boat Work.—General knowledge of—

- (a) Handling of boats under power, sail, and oars. The examination under sail and oars to be carried out in a whaler.
- (b) Hoisting, lowering, and securing a seaboat for sea.
- (c) Boats' falls, fittings, and gear and duties of coxswain.

- (d) Practical knowledge of temporary repairs to boats' hulls, mast, and fittings.

NOTE.—Where it is found impracticable to carry out the examination in boat work, commanding officers are to certify on Forms A.S.441 that the candidates are proficient in this subject.

General Duties.

- (a) To be able to steer a ship.
 (b) Sufficient knowledge of compass, elementary chart reading, and uniform system of buoyage; to undertake quarter-master's duties and coxswain of a picket boat.
 (c) Practical knowledge of sounding and taking charge of a sounding party.
 (d) Writing up the log book. Reading a barometer.
 (e) Elementary chart reading.
 (f) To be able to use a boatswain's call for calls in normal daily use.

Rule of the Road.—Practical knowledge of the regulations for preventing collisions at sea, required as coxswain of a boat. (Candidate should be assisted by illustrations and models.)

Anchor Work.

- (a) A practical knowledge of working anchors, cables, and capstans under all circumstances.
 (b) A practical knowledge of laying out anchors; weighing anchors from a boat.
 (c) All forms of fore-castle work, including "bringing to" and tending wires.
 (d) Duties when in charge of an anchor watch.

Watertight Fittings.—A practical knowledge of operating watertight doors and valves and their application to fire and collision and damage in action.

Organization.

- (a) Duties of leading hand of a mess.
 (b) Care and maintenance of decks and paintwork.

Signals.

- (a) To be able to interpret any signal in the Boats' Signal Book with the aid of the book.
 (b) Sufficient knowledge of semaphore and morse lamp; to make or read a message at a slow rate.

Examination.

In Section I, no marks are to be awarded. Candidates are to be "Passed" or "Failed".

The award of a pass is to be qualified, e.g., V.G. (85 per cent. and above), Good (70 per cent. to 85 per cent.), and Fair (below 70 per cent.) to indicate the standard reached by each man. In order that full consideration may be given to the opinion of the officers of the candidate's ship, Form A.S.264 is to be written up specially for the examination and signed by the commanding officer.

Candidates should be judged on their general bearing, the manner in which they set about the tests given to them and in which they give their orders and see them carried out. Technical knowledge is of secondary importance in this part of the examination. Attention is drawn to the fact that an able seaman passing for leading seaman must not be expected to show that power of command which is expected in a candidate for petty officer, and allowance should be made for his cultivating this during his time as leading seaman.

In Section II, marks are to be awarded in accordance with the following scales:—

For Petty Officer—

	Maximum.	Marks required to pass.
(a) Rigging	60	30
(b) Anchor work	50	25
(c) Rule of the Road	30	15
(d) Boat work	80	48
(e) General duties, including compass, lead, sounding, steering, log, barometer, &c.	60	30
(f) Organization	40	20
(g) Signals	30	15
(h) Watertight fittings	40	20

For Leading Seaman—

	Maximum.	Marks required to pass.
(a) Rigging	80	40
(b) Anchor work	60	30
(c) Rule of the Road	30	15
(d) Boat work	80	48
(e) General duties	40	20
(f) Duties in part of ship and mess	30	15
(g) Signals	30	15
(h) Watertight fittings	30	15

The knowledge required of candidates in all subjects is primarily that which they can have reasonably acquired in the type of ship in which they are serving, or, if serving ashore, in which they were last serving. It may be assumed that a man who shows he is well up in subjects connected with the ship in which he is serving can and will become equally efficient when he is drafted to one of another type.

7. When a rating applies to be examined, his commanding officer is to satisfy himself that the candidate possesses the necessary qualities which, with further experience, if necessary, will fit him to make an efficient petty officer or leading seaman, respectively. Provided that the man is otherwise qualified and that there is a reasonable prospect of his passing the examination at the time of his application, the commanding officer will forward his application for examination by the squadron board to the administrative authority or to the senior officer present in the case of ships on detached service. Should, however, a candidate be considered unsuitable by his commanding officer, his application is to be considered null and void.

8. (a) Provided that a rating is successful in both sections of the examination, the date on which he applied for examination will be the basic date of passing professionally, for record and all other purposes. In order to provide a permanent record of their basic dates, candidates' applications are to be made in the normal service manner through the request book.

(b) A rating who is successful in Section I—ability to take charge—but fails in *not more* than two technical subjects (Section II) may be re-examined in the subject or subjects in which he failed by his own ship's officers after *not less* than one month. If then successful, his basic date is to be the date of the squadron, ship or flotilla board examination. If he is failed by his ship's officers, he must, subject to sub-clause (d), be re-examined by a squadron board if for petty officer, for which re-examination he may not apply until two months have elapsed since the date of failure by his ship's officers. This date of application will be his basic date if he passes on re-examination.

(c) A rating who fails in Section I and/or in more than two subjects in Section II is to be re-examined by a squadron board, for which he may not apply until two months have elapsed since the date of his failure. This date of application will be his basic date if he passes on re-examination.

(d) A rating who fails at the third attempt to pass the squadron board examination for petty officer may not apply for re-examination by a squadron board until nine months have elapsed since the date of his third failure by a squadron board. This date of application will be his basic date if he passes. Subject to sub-clause (b), failure at the fourth attempt at the examination for petty officer is to be final.

(e) There is no limit to the number of times an able seaman may be re-examined.

9. On completion of the examination, Form A.S.441, in original, is to be forwarded to the candidate's ship, the commanding officer of which is to insert the basic date of passing the examination. The form is then to be forwarded to the Commodore of the appropriate depot, care being taken that the passing of the examination is noted on the candidates' service certificates or history sheets, and in the ledger. Forms relating to men who fail are to be retained with the men's service certificates.

When a rating fails in not more than two subjects in Section II of the examination and is recommended for re-examination by ship's officers, Form A.S.441 is to be retained in the ship until the re-examination has taken place, and the form then dealt with as for success or failure in the usual way.

Failures are to be noted on Form A.S.264 (Divisional Record Sheet).

10. Attention is drawn to C.A.F.O. 2287/44 the provisions of which are applicable to the R.A.N.

11. A revised Form A.S.441 complying with the above syllabi and instructions is in course of preparation.

12. Navy Order 215 of 1943 is cancelled.

(465/207/1266.)

By Authority: H. E. DAW, Government Printer, Melbourne,

RESTRICTED.

(FOR OFFICIAL USE ONLY.)

Commonwealth Navy Orders.

Navy Office, Melbourne,
19th June, 1945.

The following Orders, having been approved, are hereby promulgated for information and guidance, and necessary action.

By direction of the Naval Board,

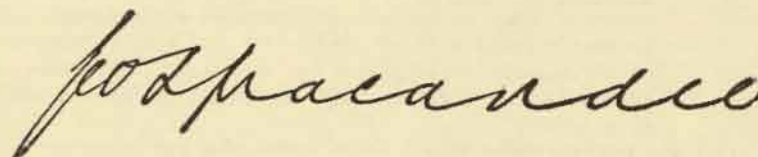

Secretary.

*The Rear-Admiral Commanding H.M.A. Squadron,
and Commanding Officers of H.M.A. Ships,
Officers in Charge of H.M.A. Naval
Establishments, and others concerned.*

TABLE OF CONTENTS.

No.	Subject.
242.	Naval Censorship.
243.	Conduct of Examinations (Non-Service).
244.	Warrant Writer Officers and Warrant Store Officers—Professional Examination.
245.	Professional Examination for Warrant Engineer and Warrant Mechanician.
246.	Training Classes for Leading Seaman and Petty Officer at Balmoral Naval Depot.
247.	W.R.A.N.S.—Professional Examination for Higher Bating—Date of Passing.
248.	Non-Substantive Ratings—Recommendations.
249.	Women's Services—Procedure when Presented to their Royal Highnesses.
250.	Examination for Advancement of W.R.A.N. Sick Berth Ratings.
251.	Summary Punishment—Stoppage of Leave Whilst Undergoing.
252.	Gunnery Practices in Small Ships.
253.	R.A.N. Women's Services—Extra Duty Allowance not Payable.
254.	Ledger Pages and Register Forms (Naval Storekeeping).
255.	R.A.N. Nursing Service—Supply of Nurses' Indoor Dresses Made-to-Measure.
256.	Dragnets—Allowance.
257.	Officers' Cap Badges.
258.	Report of Stocktaking—Form A.S. 148.

C.5750/45.

242.

NAVAL CENSORSHIP.

Paragraphs 19 and 20 of Navy Order 23 of 1944 are cancelled, and the following paragraphs are inserted in their stead:—

“ GUIDE TO CENSORABLE MATTER.

19. With a view to indicating the type of information which is classed as censorable matter, the following list has been compiled. Personnel are not to write or otherwise record or pass such information regarding:—

- (i) the past or future movements or the position at time of writing of any ships, whether warships or merchant ships, unless such past movements have been published in the Allied Press, except where a Commanding Officer has given permission to personnel, under the conditions laid down in paragraph 20 (b), to mention that they have visited a particular port. This prohibition is to be regarded as covering such movements or locations even though they be only rumoured or surmised, and also covers disclosures of movements or locations by means of references to persons whose location may be known to the addressee of a letter;
- (ii) the routine under which ships' companies are being worked;
- (iii) the conditions of and arrangements at any ports visited;
- (iv) plans of future operations whether rumoured, surmised or known;
- (v) the conditions of the writer's ship or any other ship and of the crews. This does not in any way prohibit general comment on life in ships or establishments, particularly as it relates to the individual, providing it does not convey information of specific value to the enemy, or general encouragement to him;
- (vi) actions or engagements, except as provided hereunder—
 - (a) Where an engagement in which ships of the Royal Australian Navy participated has been officially announced to the Press, commanding officers of participating vessels are authorized to establish a minimum period of not less than thirty (30) days after which personnel under their command may indicate in personal correspondence that they took part in the announced engagement and relate their personal experiences therein. The period of thirty (30) days mentioned above is a recommended minimum and commanding officers may establish longer periods when security requirements so dictate.
 - (b) Whenever any ship of the Royal Australian Navy is identified by name in an official communique or Press release announcing its participation in an engagement, the commanding officer may waive the unexpired portion of such time period as may have been established by him in accordance with paragraph (a) above.

- (c) Where the identity and location of mobile assault units engaged in a specific operation have been officially announced to the Press, landing or assault force commanders are authorized to permit all personnel of the announced units and personnel of units attached thereto for the assault phase, including corps and group staffs, to disclose in their personal correspondence their location and relate their personal experiences during the assault phase of the operation. Upon completion of the assault phase, to be determined by the transfer of command from the landing or assault force commander to the occupation force commander, such personnel may continue to relate their personal experiences which occurred during the assault phase, but thereafter disclosure of location of personnel at the time of writing shall be prohibited.
- (d) Where practicable, commanding officers of the ships concerned will be advised by signal whenever an announcement in the press has been made of the matters referred to in paragraphs (a), (b) or (c) above.
- (e) As actions, involving only an individual ship or a small detached group of ships (e.g. bombardment of coastal targets in support of Army advances) are unlikely to be published in the Press, the commanding officer may grant permission to personnel of the participating ship or ships to mention such actions in their correspondence. In such case, the action may be described only in the most general terms, e.g. “We bombarded a Japanese village the other day.” Mention is not to be made of the date or place of such action, nor of the identity of units of the Army or Air Force supporting the action or in support of which the action took place.

The Naval Board and the Naval Officer-in-Charge ashore, where mails are landed for censorship, are to be notified by signal whenever permission to mention such actions has been given, in order that shore censors may be aware of the relaxation.
- (f) The commanding officer may not grant personnel permission to mention in their correspondence any action against enemy submarines.
- (vii) personnel casualties—except with the express permission of the commanding officer;
- (viii) losses of or damage to ships of any sort prior to any official announcement;

- (ix) information concerning aerodromes, fortifications, search-lights, listening posts, barracks, camps, W/T, telephone, signal or cable stations, wharves, docks or any information relating to the activities of other Services;
- (x) criticism of the Naval, Military or Air Force of His Majesty or any of His Majesty's Allies, in such a manner as to bring them into disrepute; or
- (xi) information that may convey to the enemy the efficiency of any other branch of the Fighting Services.

20. (a) It is strictly forbidden for any Naval personnel, unless permitted by other paragraphs of this Order, to—

- (i) keep a diary of any written record of events;
- (ii) post or give to any other person to post or deliver or receive for posting or delivery a private letter, parcel or postcard other than through the Naval channels prescribed in this Order;
- (iii) send, or give to, or request any other person to send a private telegram without first obtaining the approval of the officer detailed for censorship duties;
- (iv) originate a telephone call other than a local call, without the prior approval of the officer detailed for censorship duties;
- (v) use note paper bearing any mark which indicates the locality in which a ship is or has been except insofar as this may be permitted by sub-paragraph (b) of this paragraph;
- (vi) send a photograph, picture, postcard or souvenir of a place visited by the ship or send any other article which might disclose a ship's location, past or future movements, without the approval of the Commanding Officer except insofar as this may be permitted by sub-paragraph (b) of this paragraph; or
- (vii) use any form of code whether in the shape of letters, figures, signs, symbols or plain language.

Sub-paragraphs (ii), (iii) and (iv) shall not apply to personnel in establishments where censorship has been suspended, or to personnel on long leave.

(b) After the departure of a ship of the Royal Australian Navy from a port, commanding officers are authorized to establish a minimum period of not less than thirty days after which personnel under their command may indicate in personal correspondence or by the use of note-paper which bears a mark indicating the locality of the port in question or by the mailing of photographs, pictures, postcards or souvenirs, that they visited the port in question. The period of thirty days mentioned above is a recommended minimum and Commanding Officers may establish longer periods when security requirements so dictate."

(1835/2/675.)

(This Order will be reprinted for posting on Notice Boards.)

243.

CONDUCT OF EXAMINATIONS (NON-SERVICE).

Owing to the increased number of personnel taking examinations through the various educational institutions under the R.A.N. Education Service, it has been found necessary to introduce a uniform procedure. In order to minimize the work of officers connected with the conduct of these examinations, and at the same time ensure that the validity of the examinations will not be jeopardized, commanding officers are to see that the instructions laid down hereunder are adhered to strictly.

2. Students who are eligible to sit for examination will be sent an examination entry form some time before the date of examination. This form is to be completed and returned in accordance with the regulations of the examining institution.

3. Examination question papers will be forwarded through the Director of Education and Vocational Training to the commanding officer of the ship concerned, and receipt of these question papers is to be acknowledged on Form A.S.1303 to the Director of Education and Vocational Training.

4. All worked examination papers are to be forwarded through the commanding officer to the Director of Education and Vocational Training in a confidential envelope, and receipt of papers will be acknowledged by the Director of Education and Vocational Training by letter through official mail channels. Under no circumstances are worked examination papers to be returned direct to the educational institution conducting the examination. If examination papers are received direct from an educational institution, the matter is to be reported without delay to the Director of Education and Vocational Training, and the examination is to be proceeded with in accordance with the instructions hereunder.

5. All examination papers, worked and unworked, are to be treated as *Confidential Papers*, and forwarded in accordance with rules governing forwarding of confidential papers.

6. Sub-paragraph (i) of paragraph 11 of this Order—"Instructions to Supervising Officers"—details the correct procedure for the return of worked papers. It is essential that this procedure be carried out in every detail.

7. If a candidate signifies his intention of not sitting, the question papers must be returned unopened to the Director of Education and Vocational Training. Papers so forwarded must be accompanied by a letter from the commanding officer giving reasons for the candidate's failure to sit.

8. In the event of a candidate's being drafted to another ship or establishment prior to sitting for the examination, the question papers and stationery should be forwarded immediately to the commanding officer of the candidate's new ship or establishment for necessary action. If in doubt, papers are to be returned forthwith to the Director of Education and Vocational Training by fastest available method, with an explanatory letter, telling why the papers have been returned.

9. If, through Service conditions, a candidate is prevented from sitting for an examination on the proper date, he may take the examination at the earliest opportunity following that date, providing the conditions laid down in sub-paragraph (j) of paragraph 11 of these instructions are complied with. The decision will rest with the examining institution as to whether his examination papers can be accepted.

10. The provisions of this Order notwithstanding, if a candidate is able to present himself on the day of examination at the place where the examination is normally held, either while on leave, or with the permission of his commanding officer, he may sit for the examination in the same manner as a civilian, providing necessary arrangements can be made. As soon as a candidate knows that he or she can sit as a metropolitan candidate, he or she should notify the Director of Education and Vocational Training, so that arrangements can be made, unless the shortness of the time demands that the civilian authorities be approached direct. If this happens, the Director of Education and Vocational Training should be notified as soon after as possible.

11. *Instructions to Supervising Officers.*

(a) The supervising officer must remain in the room during the whole of the examination, but, if compelled or required to leave for any reason, should not do so unless proper supervision is arranged for.

(b) A candidate should not be permitted to leave the room unless adequate supervision is arranged during his absence.

(c) No books or memoranda should be assessible to candidates under examination unless specified in special instructions.

(d) No one except candidates and those officially connected with the examination are allowed to enter the examination room.

(e) Strict silence is to be enforced, and candidates should be seated in such a way as to guard against copying or any possibility of collusion.

(f) Examination papers will be forwarded to the commanding officer in a sealed cover indicating the name of the candidate and the subject. The seal is to be broken by the supervising officer in the presence of the candidate at the time appointed in the time table, or as shown on the outer envelope, for the particular subject.

(g) Supervising officers should make sure that candidates' worked papers are correctly filled in by the candidates, i.e., examination number, subject, and paper (first or second).

(h) The papers in each subject must be initialled by the supervising officer in the top right-hand corner of the first page as soon as they are received from the candidate.

(i) The answers for each paper should be forwarded immediately after each examination in the addressed envelopes supplied. Two special envelopes will be supplied for this purpose, viz., an inner envelope addressed to the university or college conducting the examination, and an outer envelope marked "CONFIDENTIAL," addressed to the Director of Education and Vocational Training, 341 Collins-street, Melbourne. The inner envelope will indicate the subject, candidate's examination number (if applicable), and date and time of examination. Supervisors will initial the inner envelope as a guarantee that the

examination has been held under the conditions laid down. This envelope will then be returned in the outer envelope to the Director of Education and Vocational Training. Outer envelopes will also bear the name of the candidate, the name of the subject and, when there is more than one paper, the number of the paper (e.g., first paper, or second paper). Supervisors are to ensure that papers are returned in the correct envelopes.

Mathematical tables supplied to the candidates should be returned under separate cover to the same address.

(j) Should Service conditions render it impossible for the candidate to sit for the examination on the date shown on the official time table for the working of the paper, he shall be permitted to take the test as opportunity offers, provided the worked papers are accompanied by a statutory declaration from the candidate and a letter from the commanding officer explaining the circumstances. The statutory declaration shall be to the effect that the candidate had no knowledge of the contents of the paper at the time of his sitting for the examination.

(840/201/31.)

244.

WARRANT WRITER OFFICERS AND WARRANT STORES OFFICERS—PROFESSIONAL EXAMINATION.

The next professional examination for the ranks of warrant writer officer and warrant stores officer will be held in December, 1945.

2. The commanding officers of H.M.A. ships and naval establishments are requested to forward to Navy Office not later than the 1st October, 1945, a list of names of candidates desirous of sitting for this examination. Blank returns are required.

(465/207/1271.)

(This Order will be reprinted for posting on Notice Boards.)

245.

PROFESSIONAL EXAMINATION FOR WARRANT ENGINEER AND WARRANT MECHANICIAN.

The next professional examination for the ranks of warrant engineer and warrant mechanician will be held about December, 1945.

2. The commanding officers of H.M.A. ships and naval establishments are requested to forward to Navy Office not later than 1st September, 1945, the names of candidates desirous of sitting for this examination. Blank returns are required.

3. Commanding officers should satisfy themselves that candidates are qualified in accordance with K.R. and A.I., Article 313, as regards:—

- (a) Educational test for warrant rank;
- (b) Service and character;
- (c) Certificates;

before being allowed to take the examination.

(465/207/1272.)

(This Order will be reprinted for posting on Notice Boards.)

246.

TRAINING CLASSES FOR LEADING SEAMAN AND PETTY OFFICER AT BALMORAL NAVAL DEPOT.

The training of able seamen for leading seamen in organized classes at Balmoral Naval Depot referred to in Navy Order 331 of 1942 is no longer necessary because of the large pool of able seamen passed for leading seamen which now exists in the R.A.N.

2. A need for additional leading seamen passed for petty officer does however exist, and to assist leading seamen to pass for petty officer, courses of one month's duration at Balmoral Naval Depot have been introduced.

3. Ships and establishments are to report to the Naval Officer-in-Charge, Flinders Naval Depot, at the beginning of each month, the names of leading seamen who are recommended for this course. Names of those having a reasonable chance of passing for petty officer without a course are not to be reported but are to be dealt with in the usual manner.

4. Navy Order 331 of 1942 is cancelled.

(614/216/11.)

247.

W.R.A.N.S.—PROFESSIONAL EXAMINATION FOR HIGHER RATING—DATE OF PASSING.

The date of passing all professional examinations for higher rating, except those held on fixed dates, is to be the date of application for the examination which a candidate subsequently passes.

2. The date of application for such examination is to be recorded as the basic date on the Form A.S. 161 reporting the date of passing.

3. In order to provide a permanent record of the basic date, candidates' applications are to be made in the normal service manner through the request book.

4. The examinations for higher rating which are held on fixed dates are:—

<i>Rating.</i>	<i>Category.</i>
Leading Wran	Sick Berth Attendant, Telegraphist, V/Signaller, T/P Operator, Signaller A/M, Coder.
Petty Officer Wran ..	Writer (G.D.), Writer (P. & A.), Stores Assistant (Stores), Stores Assistant (Vicuallling), Stores Assistant (Clothing, Mess Traps, and Mess Utensils), Sick Berth Attendant, Telegraphist, V/Signaller, T/P Operator, Signaller A/M, Coder.

5. The provisions of this Order are *not* applicable to examinations or trade tests held for the purpose of transferring to a higher pay grouping.

(432/224/3558.)

248.

NON-SUBSTANTIVE RATINGS—RECOMMENDATIONS.

With reference to A.F.O. 6525/44, it is observed that insufficient recommendations for gunnery rates are being received to compete with wastage and the ever-increasing manning requirements.

2. In this regard, it is pointed out that the substitution of a Bofors for an Oerlikon requires an increase of one A.A.2 and one A.A.3 for each mounting so exchanged.

3. The attention of all commanding officers is drawn to paragraphs 11 and 14 of the above-mentioned A.F.O.

4. In the R.A.N., men recommended for 3rd class rates should equal the number of 3rd class rates allowed by complement.

5. Immediately prior to the arrival of a ship in a refitting port in Australia, a final and up-to-date A.S. 1303 of ratings recommended is to be forwarded by air mail. Endeavour will then be made to relieve ratings recommended, and for the ship to remain untouched from a drafting point of view until her return to a refitting port in Australia.

6. Unless sufficient ratings are recommended and can be brought forward for training, dilution in accordance with A.F.O. 6795/44 with modifications to suit R.A.N. manning requirements will have to be introduced.

(348/215/6.)

249.

WOMEN'S SERVICES—PROCEDURE WHEN PRESENTED TO THEIR ROYAL HIGHNESSES.

The following instruction is issued for the guidance of all concerned:—

(a) Women's Services whose Regulations prescribe the hand salute.

(i) Women officers and members, wearing head-dress, when presented to Their Royal Highnesses should salute, and, when shaking hands, should curtsey.

(ii) Women officers and members not wearing head-dress, when presented to Their Royal Highnesses, should stand at attention and, when shaking hands, should curtsey.

(b) Women's Services whose Regulations do not prescribe a hand salute.

(i) Women officers and members whether wearing head-dress or not should, when presented to Their Royal Highnesses, stand at attention, and, if shaking hands, should curtsey.

(432/224/3782.)

250.

**EXAMINATION FOR ADVANCEMENT OF W.R.A.N. SICK
BERTH RATINGS.**

Examinations for advancement of W.R.A.N. sick berth ratings are to be held twice a year, in February and August. The numbers (but *not* names) of candidates sitting for (a) sick berth petty officer, and (b) leading sick berth attendant, are to be reported to Navy Office not later than the 15th January, or 15th July. Nil returns are to be rendered.

2. The written examination papers will be set by a medical officer at Flinders Naval Depot, and will consist of two papers covering the syllabus laid down on Form A.S.1237, except that question 15 is to be deleted and substituted by a question on elementary gynaecology. The oral and practical test will be the same as for male sick berth ratings.

3. The written examination papers will be forwarded to examination centres by the Director of Naval Medical Services. The oral and practical examination is to be carried out as soon as possible after the completion of the written examination, and the results noted *in figures* on Form A.S.1237. These forms in duplicate, together with the worked papers, are then to be forwarded to the Director of Naval Medical Services.

4. Candidates will be required to obtain in the oral as well as in the written examination the standard of marks required for a pass, but, where a candidate obtains marks 10 per cent. below the percentage prescribed in either the practical or the written parts of the examination, she will be considered as passed if she obtains sufficient marks in the other portion of the test to bring her total marks up to the prescribed percentage.

5. Each candidate will be allotted an examination number, and only the distinguishing number, and not the candidate's name, is to be shown on the worked papers. The examination number allotted to each candidate should be shown on Form A.S.1237 as well as the rating's name in order that, when the papers have been corrected, each rating's identity will be known in Navy Office to enable the final results to be published without delay.

(432/224/3322.)

(This Order will be reprinted for posting on Notice Boards.)

251.

**SUMMARY PUNISHMENT—STOPPAGE OF LEAVE WHILST
UNDERGOING.**

The directions contained in A.F.O. 1260/1945 concerning stoppage of leave whilst undergoing summary punishment are to be observed in the Royal Australian Navy.

(452/201/2070.)

252.

GUNNERY PRACTICES IN SMALL SHIPS.

It has become apparent from the ammunition returns that certain small ships are not carrying out any firing practices.

2. While it is realized that it is very difficult and at times even impossible for small ships and local defence craft to carry out organized target practices, it is essential that all weapons be fired occasionally in order to ensure their adequate maintenance and to give the gun's crews some idea of how their weapons sound and behave.

3. The periods between actual firings should not normally exceed one month. An improvised target should be used if no other be available.

(490/201/2077.)

253.

**R.A.N. WOMEN'S SERVICES—EXTRA DUTY ALLOWANCES
NOT PAYABLE.**

It is promulgated for general information that no authority exists in Naval Financial Regulations and Instructions for payment of non-substantive and extra duty allowances to members of the R.A.N. Women's Services.

2. In certain establishments, wran stewardesses have incorrectly been credited with the allowance for "care of mess traps" and, in addition, applications have been received for payment to wrans of the allowances provided in Naval Financial Regulations and Instructions, Articles 73 and 82, for shorthand writers and for telegraphists performing "special duty".

3. When there is no alternative, wran stewardesses may be deputed to the duty of "care of mess traps", although an extra allowance is not payable; but the instructions contained in the Manual of Victualling, Chapter XIII, for charges against pay in respect of deficiencies which may occur are not to be applied to them. The provisions of Naval Financial Regulations and Instructions, Article 9, are, however, to be observed, where applicable.

4. It is a Governmental direction that the greatest possible measure of uniformity in pay and conditions of service is to be preserved between the Women's Services of the Navy, Army and Air Force. The rates of active pay, which are similar in all such Services, have accordingly been established in groups to provide for variation in nature of duties and qualifications held.

(407/201/1393.)

254.

LEDGER PAGES AND REGISTER FORMS (NAVAL STOREKEEPING).

Stocks of Naval Storekeeping Forms A.S.123A, A.S.146, A.S.151, A.S.153, A.S.155A, A.S.155B, A.S.155C, A.S.155x, A.S.155y, and A.S.155z are now maintained at Melbourne, Fremantle and Brisbane as well as Sydney, and H.M.A. ships and establishments should demand ledger pages and register forms at the most convenient port.

2. Ledger pages, forms A.S.123A, A.S.146, A.S.151, and A.S.153, all of which require to be serially numbered and initialled by an inspecting officer (naval storekeeping) before issue, should be demanded by memorandum from the authority concerned at the appropriate port, viz.:-

Melbourne .. Director of Naval Stores, Navy Office.
 Sydney .. Inspecting Officer (Naval Storekeeping) C/o.
 Superintending Naval Store Officer.
 Fremantle .. Naval Store Officer.
 Brisbane .. Naval Store Officer.

3. Register Forms A.S.155 series (except A.S.155B) are supplied in the same manner as all other forms, stationery, etc., and should be demanded on Forms A.S.134D from the naval store depot at any of the above-mentioned ports.

4. Forms A.S.155B as necessary will accompany each issue of ledger pages referred to in paragraph 2 above.

(480/202/3730.)

255.

R.A.N. NURSING SERVICE—SUPPLY OF NURSES' INDOOR DRESSES, MADE-TO-MEASURE.

Indoor dresses, made-to-measure, required by personnel of the R.A.N. Nursing Service to meet replacements, are obtainable as private transactions from the following outfitters:-

Melbourne.

Lucy Secor, The Block, Collins-street.
 Sister Susie, Block Court, 4th Floor, 290 Collins-street.

Sydney.

David Jones Ltd., Marlborough-street, Surry Hills.

2. The prices of the garments are as shown hereunder and are inclusive of the cost of all materials. Postage charges, if incurred, are additional.

		Indoor dress with collar and buttons	Indoor dress with collar but without buttons
		£ s. d.	£ s. d.
Lucy Secor	1 14 0	.. 1 12 0
Sister Susie	1 9 0	.. 1 8 3
David Jones Ltd.	1 8 6	.. 1 8 0

3. Nurses unable to attend personally at the outfitters may utilize self-measurement forms which will be supplied by the outfitters on application.

4. When ordering garments, nurses must furnish the outfitter with the necessary "Authority to Supply" as provided in paragraph 2 of Navy Order 630 of 1944. Unless this duly completed form of authority is furnished, the order will not be accepted by the outfitter.

(434/201/3600.)

256.

DRAGNETS—ALLOWANCE.

Approval has been given to the addition of the under-mentioned items to the list of special allowances of naval stores for H.M.A. destroyers, other than "Tribals," Frigates and A.M.S. Vessels:-

Dragnets, 50 yards by 7 feet .. 1 No. .. For Recreational Purposes
 (Not if already supplied with a Pattern 36 Seine Net)

2. Ships concerned not already carrying a dragnet should forward demands (Form A.S.134D) to the nearest naval store depot.

3. Navy Order 311 of 1943 is cancelled.

(612/232/104.)

257.

OFFICERS' CAP BADGES.

Adequate stocks of officers' metal cap badges are now available and issues of the embroidered badge are in future to be confined to officers of commander's rank and above.

2. Navy Orders 45 and 244 of 1943 are cancelled.

(416/201/933.)

258.

REPORT OF STOCKTAKING—FORMS A.S. 148.

When reports of stocktaking, Forms A.S. 148 (outside) and (inside), are being prepared following a muster of naval stores, care should be taken that all essential particulars provided for on the forms are furnished. It is necessary that the date of the previous, as well as the current, stocktaking and the number of items mustered be shown in the reports.

2. A careful inquiry should be made as to the cause of the discrepancies and full explanations given in the appropriate column of the report of stocktaking.

3. Detailed instructions for the preparation and disposal of reports of stocktaking, Forms A.S. 148, are given in chapter XVI of the Naval Storekeeping Manual, B.R.4, and paragraph 78 of the R.A.N. Supplement thereto and should be closely adhered to.

(612/207/3196.)

any

RECEIVED 12 JUL PM 45 NAVY REGISTRY

259—263/45

RESTRICTED.

(FOR OFFICIAL USE ONLY.)

Commonwealth Navy Orders.

Navy Office, Melbourne,

26th June, 1945.

The following Orders, having been approved, are hereby promulgated for information and guidance, and necessary action.

By direction of the Naval Board,

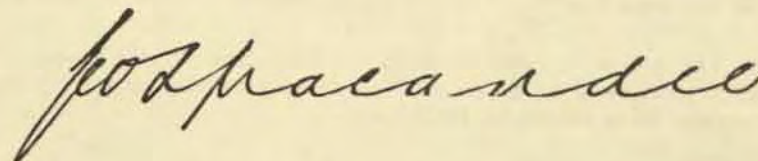

Secretary.

*The Commodore Commanding H.M.A. Squadron,
and Commanding Officers of H.M.A. Ships,
Officers in Charge of H.M.A. Naval
Establishments, and others concerned.*

TABLE OF CONTENTS.

No.	Subject.
259.	W.R.A.N.S. Advancement.
260.	A.M.S. Vessels—4-in. W/T Aerial Trunk.
261.	Supplies of Naval Stores to R.N. Forces at Australian Ports.
262.	Fire Fighting Equipment—H.D.M.Ls. and Other Small Craft.
263.	Khaki Drill Service Dress for Officers.

259.

W.R.A.N.S. ADVANCEMENT.

As from 1st July, 1945, the roster for advancement in the W.R.A.N.S. which is under the control of Naval Officer-in-Charge, Flinders Naval Depot, will be placed on a fleet number basis.

2. Higher W.R.A.N. ratings are allowed in each establishment (grouping all categories) in the proportion of:—

- 1—Petty officer wran.
- 2—Leading wrans.
- 9—Wrans.

3. If it is considered necessary, however, in the case of sections and out-stations, which possess few wran personnel, to provide for vacancies for advancement in excess of the proportion of 1 : 2 : 9, the commanding officer may forward a recommendation, supported by details, to the Naval Officer-in-Charge, Flinders Naval Depot, who, if he considers the circumstances justify such increase, may authorize further advancements provided that the following overall proportion in such establishment is not exceeded:—

- 1—Petty officer wran.
- 2—Leading wrans.
- 6—Wrans.

(432/224/1272.)

260.

A.M.S. VESSELS—4-in. W/T AERIAL TRUNK.

It has been reported that trouble is caused through accumulation of water in the 4-in. W/T aerial trunks fitted in A.M.S. vessels.

2. The present method of securing the bottom of the trunk with a flange screwed down to the wooden decking is not satisfactory as a water-tight joint cannot be maintained.

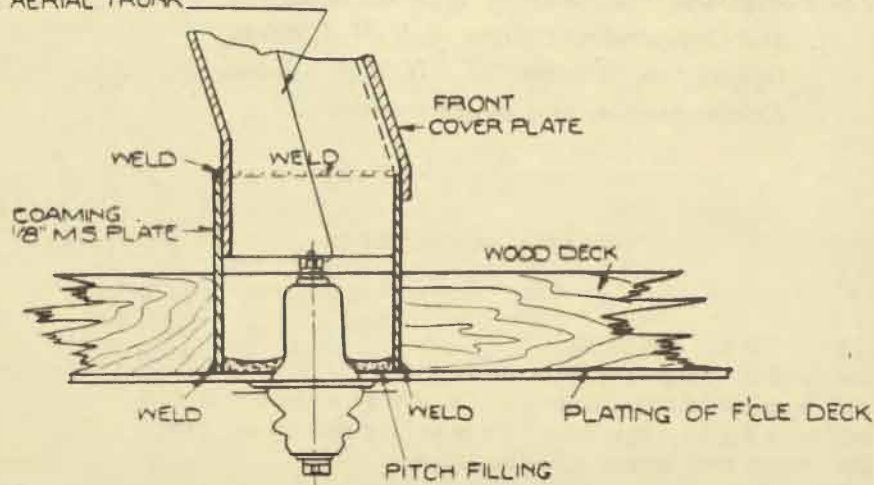
A.M.S. VESSELS.**4" AERIAL TRUNK****4" AERIAL TRUNK**

3. Ships concerned should include an item in their next list of defects for modification of the trunking, to be welded to the deck as shown in the diagram appended to this Order.

(603/267/1610.)

261.

SUPPLIES OF NAVAL STORES TO R.N. FORCES AT AUSTRALIAN PORTS.

The following particulars of arrangements for dealing with requirements of naval stores at Australian ports for R.N. ships and allied vessels including R.N. vessels manned by R.A.N. personnel, viz., 21st and 22nd M/S Flotillas and "N" and "Q" Class Destroyers are promulgated for information:—

Sydney.—All supplies will be made from the R.N. Naval Store Depot.

Brisbane.—Pending the establishment of an R.N. Naval Store Depot at Brisbane, demands for naval stores required by R.N. ships should be forwarded direct to the R.N. Naval Store Depot, Sydney.

Fremantle, Melbourne, Adelaide.—R.A.N. Naval Store Depots at Fremantle and Melbourne and the Base Naval Store at Pt. Adelaide will meet demands of R.N. ships based on or refitting at these ports. In addition, these depots will satisfy demands by visiting R.N. vessels to the extent that stocks permit. In cases where the latter ships are not proceeding to a main storing port and it is essential for replenishment to be made at Melbourne, or Adelaide in particular where large stocks are not maintained, demands which cannot be satisfied are to be forwarded by the R.A.N. depot to the Superintending Naval Store Officer (R.N.), Sydney, for supply from the R.N. Naval Store Depot, Sydney, direct to the ship concerned. Arrangements made should in each instance be communicated to the ship.

Darwin, Townsville.—As stocks of naval stores will not permit other than small casual supplies, demands from R.N. ships other than for casual supplies should be forwarded by ships concerned direct to the R.N. Naval Store Depot, Sydney, until R.N. stocks are established at other ports.

Other Ports.—Demands from R.N. ships should be forwarded by ships concerned direct to the R.N. Naval Store Depot, Sydney, until R.N. stocks are established at other ports.

(1990/5/71.)

FIRE FIGHTING EQUIPMENT—H.D.M.Ls. AND OTHER SMALL CRAFT.

The allowances of naval stores for fire fighting and repair purposes for Fairmiles, H.D.M.L'S, Motor Patrol Boats and Air Sea Rescue Vessels are as shown in the appendix to this Order. These allowances supersede those indicated in any relevant Admiralty Printed Establishment.

2. Where, however, shortages of supply of items allowed or other considerations exist, the individual types provided may be varied if desired.

3. Other vessels or craft not specified in R.A.N. allowances are to be supplied up to the R.A.N. allowance of vessels or craft to which they are sufficiently similar.

APPENDIX.

ALLOWANCES OF NAVAL STORES FOR FIRE-FIGHTING AND REPAIR PURPOSES FOR MOTOR LAUNCHES, MOTOR PATROL BOATS AND AIR SEA RESCUE VESSELS.

PERMANENT STORES.

Sub Head.	Patt. No.	Description.	Denom-ination.	Allowances.				Remarks.
				Fair-miles.	H.D.M. L'S.	Motor Patrol Boats.	A.S.R. Vessels.	
B. 8	4723	Extinguishers, fire, "Pyrene", 1 quart	No.	3	1	1	1	(a) Includes 2 No. for crew space. If paraffin heaters are fitted, 2 No. "Nuswift" type fire extinguishers should be drawn in lieu for this purpose (b) Pump already allowed by establishment for clearing petrol from bilges is to be utilized as emergency fire pump (c) 1 No. additional 30' hose to be supplied with each set
"	4726	Extinguishers, fire, foam type, 2 gallons ..	"	6 (a)	5	5	5	
"	4726a	Hoses, armoured for foam type fire extin-guishers ..	"	6	5	5	5	
"	"	Extinguishers, fire, "Nuswift" ..	"	1	"	"	"	
"	"	Extinguishers, fire, hand CO. 2, "Lux" type, 12 lb. ..	"	3	2	"	"	
"	"	Pumps, bilge, hand operated, complete with hoses ..	"	1 (b)	"	"	"	
"	"	Hoses, canvas, No. 1 size x 65' ..	"	1	"	"	"	
"	"	Hoses, canvas, No. 2 size x 40' ..	"	2	2	"	"	
"	"	Hoses, canvas, No. 2 size x 20' ..	"	6	"	"	"	
B. 9	1520	Branch pipes, jet spray typ. No. 2 size (new type) ..	"	2	1	"	"	

PERMANENT STORES—continued.

Sub Head.	Patt. No.	Description.	Denom-ination.	Allowances.				Remarks.
				Fair-miles.	H.D.M. L'S.	Motor Patrol Boats.	A.S.R. Vessels.	
B. 10	31	Buckets, fire ..	No.	3	3	3	3	(d) When employed on A.S.R. duties
"	"	Stirrup pumps, complete with 4-gallon portable water conts. ..	"	2 (e)	1 (e)	1 (e)	1 (e)	(e) 1 No. pump, complete with 2 No. water containers for each main section of the ship.
E. 5	230	Breathing apparatus, complete with hose and strainer ..	Sets	2 (c)	1 (c)	1 (d)	1	
F. 2	8115	Lanterns, Oldham, Hower type ..	No.	2	2	2	2	* These items should be demanded from the Superintending Victualling Store, Officer, Sydney
"	16034	Headlamp, electric, miner's type ..	"	2	1	1	1	
		<i>Protective Clothing.</i>						
"	*	Fearnought suit (jacket and trousers) ..	"	3	2	1	1	
"	*	Fearnought hoods ..	"	3	2	1	1	
"	*	Fearnought gauntlets ..	"	3	2	1	1	

CONSUMABLE STORES.

A	"	Plugs, soft wood—						
"	"	2" tapering to 1", 6" long ..	No.	10	6	6	6	(a) Asbestos cloth to be supplied in lieu if available.
"	"	3" tapering to 2", 6" long ..	"	"	6	6	6	
"	"	4" tapering to 3", 6" long ..	"	"	3	3	3	(b) Includes 4 No. spare.
"	"	6" tapering to 4", 6" long ..	"	"	3	3	3	
"	"	3" tapering to 2", 8" long ..	"	10	"	"	"	(c) Includes 2 No. spare.
"	"	4" tapering to 3", 9" long ..	"	5	"	"	"	
"	"	6" tapering to 4", 12" long ..	"	5	"	"	"	(d) 1 for each member of the crew plus 1 spare.
B. 8	"	Refills for "Pyrene" extinguishers ..	"	6	2	2	2	
"	4729	Charges, spares for foam type extin-guishers ..	"	12	10	10	10	(e) 1 No. for each pattern 8115, lantern carried, if desired.
"	"	Charges, spare for "Nuswift" ..	"	4	"	"	"	
D. 3	"	Fearnought, 4" x 4" ..	Pcs.	2	1	2 (a)	2 (a)	
E. 2	"	Gloves, asbestos ..	"	1	"	"	"	
F. 2	"	Torches, hand, 2-cell type ..	No.	20 (b)	12 (c)	(d)	(d)	
"	16035	Light shields for Oldham lanterns ..	"	(e)	(e)	(e)	(e)	

263.

KHAKI DRILL SERVICE DRESS FOR OFFICERS.

With reference to the Uniform Regulations for Officers of the Fleet, as contained in the Appendix to Admiralty Navy List, the Naval Board have approved that khaki drill service dress may be worn as an optional dress by R.A.N., R.A.N.R. and R.A.N.V.R. officers in shore establishments, or otherwise employed ashore, when khaki tropical dress would normally be worn or instead of No. 10 dress on informal occasions at night.

2. When worn, khaki drill service dress is, except for the distinctive R.A.N. gilt buttons, to conform to the following particulars contained in R.N.T.M. (A), No. 3, relating to the wearing of this dress by officers of the British Pacific Fleet whilst in Australia:—

- (a) The jacket is to be the same pattern as the military service dress with belt of the same material, and blue shoulder straps are to be worn.
- (b) Trousers are not to have cuffs or other turn up.
- (c) Khaki shirt and black tie are to be worn, shoes being either black or brown.
- (d) Khaki cap cover is to be worn.

3. The necessary arrangements for the supply of this dress are being made with the naval outfitters operating in the several States under the current agreement for the supply of officers' uniforms, also with the Commonwealth Government Clothing Factory, and details and prices will be promulgated in Navy Orders at an early date. Meanwhile, R.A.N. officers may place their orders with the outfitters referred to, who at present supply officers of the British Pacific Fleet and are utilizing a standardized khaki drill material, Naval requirements of which are procured by outfitters from Army stocks.

(584/206/130.)

RECEIVED
19 JUL 1945
NAVY REGISTRY

264/45.

RESTRICTED.

(FOR OFFICIAL USE ONLY.)

Commonwealth Navy Order.

Navy Office, Melbourne,
26th June, 1945.

The following Order, having been approved, is hereby promulgated for information and guidance and necessary action.

By direction of the Naval Board,

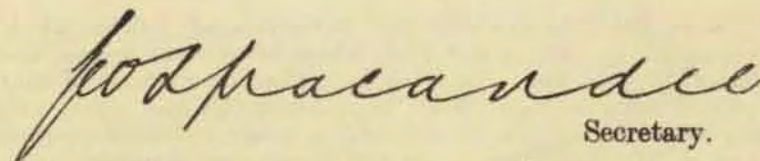
Secretary.

*The Commodore Commanding H.M.A. Squadron,
and Commanding Officers of H.M.A. Ships,
Officers in Charge of H.M.A. Naval
Establishments, and others concerned.*

TABLE OF CONTENTS.

No.	Subject.
264.	Kit Bags, Hammocks, &c.—Losses during Transport—Labelling and Marking.

C.6231/45.

264.

**KIT BAGS, HAMMOCKS, ETC.—LOSSES DURING TRANSPORT—
LABELLING AND MARKING.**

Many claims have been received for compensation in respect of kit bags, hammocks, &c., lost whilst in transit by rail. On investigation, it has been found that, in numerous instances, the losses have been due to—

- (a) insufficient or incorrect marking and labelling of the items; and
- (b) failure on the part of ratings to realize fully their responsibilities in connection with their kits whilst on draft.

Accompanied Baggage.

2. It is to be made clear to all ratings, that although they may, whilst on draft, become separated from their kit bags, hammocks, &c., they are not relieved from the responsibility of sighting them from time to time and taking every precaution to prevent their loss. A sense of personal responsibility on the part of every man is a natural and essential requisite and every one must realize that, if he abandons his own personal supervision of his belongings, he cannot subsequently expect others to find missing items or the Service to make good consequent losses. On the other hand it is equally important that all care and vigilance should be exercised by responsible persons in ships and establishments to ensure that compensation for losses occurring beyond the control of ratings is reduced to a minimum.

3. In order to facilitate the restoration of articles which may become lost in transit and from which labels have become detached, immediate steps are to be taken by commanding officers of ships and establishments to have all kit bags, hammocks, tool chests, suitcases, &c., belonging to ratings attached to their command, permanently marked with the ratings' names and initials, official numbers, and home ports. With regard to kit bags, experience has shown that it is more advantageous to mark this item along the side instead of at the bottom of the bag, as markings in the latter position are subject to mutilation and sometimes complete obliteration whilst the bag is in transit. Kit bags, therefore, are to be marked along the side.

4. Prior to draft from ships and establishments, the effects of ratings are to be inspected to ensure that the following instructions have been complied with, viz. :—

- (a) that each item is permanently marked with a rating's name, official number and home port, as directed in paragraph 3;
- (b) that a label, setting out that the following details, and no others, is securely attached to each item :—

Name.....
Rating..... Official No.....
Destination.....

(Rail Station only)

(c) that other out-of-date labels and railway stickers are removed or effectively cancelled;

(d) that kit bags, tool chests, suitcases, &c., are securely locked;

With regard to (d), unless kit bags, tool chests and suitcases are securely locked during transport, responsibility will not be accepted by the Department for loss by theft of any portion of the contents.

Unaccompanied Baggage.

5. Unaccompanied baggage landed by a ship to a shore establishment is to be dealt with as set forth in paragraph 4 and, in addition, the reason for the landing of the baggage is to be noted in capital letters on the outside of each package, as follows :—

“ Sick on shore ”
“ Absentee ”
“ Leave ”
“ Drafted ”
“ Deceased rating ”
“ Prisoner of war ”
“ Unclaimed ”
“ Onward transport to.....”, &c.

Signalled advice of the landing of the baggage, and the reason therefor, is to be forwarded to the establishment where landed, and where onward transmission is required, repeated to naval establishment at point of destination.

6. Unaccompanied baggage required to be sent by rail to a naval establishment in another State is in all cases in future to be despatched through the Military Forwarding Organization and the consignment of such baggage by goods train, as directed in Article 243, clause 3, Naval Financial Regulations and Instructions, is to be discontinued. Consignments handled by Military Forwarding Organizations are promptly despatched by troop trains which run daily between Melbourne, Sydney, and Northern States, and tri-weekly between Melbourne and Western States. In cases of extreme urgency, however, Military Forwarding Officers will arrange for packages, of a weight not exceeding 112 lb., to be despatched by passenger train on representations being made, but, having in view the frequent running of troop trains as indicated above, and the higher rates of freight prevailing for consignments by passenger train, this method of transport must not be resorted to unless extreme urgency exists.

7. The location of Military Forwarding Officers in the capital cities of each State is as follows :—

Melbourne.—602 Little Collins-street, Melbourne.
Sydney.—21 Pier-street, Sydney.
Brisbane.—Railway Parcels Office, Roma-street, Brisbane.
Darwin.—Care of Army Movement Control, Darwin.
Hobart.—Anglesea Barracks, Hobart.
Adelaide.—137 North-terrace, Adelaide.
Perth.—Railway-terrace, Perth.

At other centres, the local Military Rail Transport Officer performs the functions of Military Forwarding Officer.

8. When despatch of baggage through Military Forwarding Organization is desired, the commanding officer of the naval establishment concerned is to arrange for the items properly marked, locked (where applicable) and labelled as indicated in paragraphs 4 and 5, to be delivered to the local Military Forwarding Officer for onward transmission, a detailed receipt being obtained for the packages comprising the consignment. The despatching establishment will then communicate to the receiving establishment, by signal, particulars of the packages consigned, stating names, ranks or ratings, official numbers, and, in cases where consignments originate from the despatching establishment, reason for despatch.

9. When baggage is delivered to Military Forwarding Organization for despatch to *Huon*, in which case transmission by sea becomes necessary, kit bags, suitcases and packages, are to be packed in bulk cases and a list of the items contained therein is to be enclosed in each case. The total weight of each case with contents must not exceed 2 cwt. Hammocks are not to be cased but are to be wired in bundles not exceeding six.

10. Confirmation of transmission of baggage through Military Forwarding Organization is to be forwarded by the despatching naval establishment on Form D.80, two copies being forwarded by post to the receiving establishment and care taken to ensure that one copy is returned receipted within a reasonable time. The names of the personnel concerned and official numbers of ratings should invariably be shown on Form D.80.

11. On the arrival of the baggage at point of destination, the local Military Forwarding Officer will notify the commanding officer of the naval establishment concerned who is to arrange for the packages to be collected at the earliest possible moment and for the Form D.80 referred to in paragraph 10 to be receipted and returned to the despatching naval establishments. Care is to be taken that baggage collected from the Military Forwarding Officer is closely examined before acceptance and that the attention of that officer is drawn to any visible signs of the packages having been tampered with *en route*.

12. Should baggage become lost in transit, the despatching establishment, on receipt of advice from the receiving establishment, is to notify the local Military Forwarding Officer who, in accordance with instructions issued by Army Movement Control Headquarters, will take necessary action in the endeavour to locate the baggage, and, if not successful, lodge a claim with the Transportation System concerned for the value of the missing items. When notifying the Military Forwarding Officer of the non-receipt of baggage, an estimated value of the missing consignment should be furnished.

13. It is very necessary that advices of despatch of baggage should be kept constantly under review and that inquiries to trace same are made immediately it is found to be missing. Written replies should be obtained wherever possible. If it be established that the baggage has been lost, all correspondence including signals is to be forwarded to Navy Office with the claim for compensation, which should give full details of the items lost.

Baggage Store Arrangements.

14. When kit is deposited in a baggage store at a shore establishment, a receipt must in every case be given by the senior rating in charge of the store. In the event of subsequent loss, this receipt will require to be produced by the rating concerned in support of a claim for compensation. When kit is landed by a ship in the absence of the rating, the receipt is to be retained on board and attached to any correspondence relating to the loss of kit.

15. Where not already in operation, a baggage register is to be introduced to record all packages received in baggage stores, accompanied or unaccompanied, as follows:—

- (a) Date received;
- (b) from whence received;
- (c) name of owner;
- (d) rank or rating;
- (e) official number;
- (f) description of items and condition;
- (g) reason for stowage;
- (h) rack in which stowed;
- (i) date of withdrawal;
- (j) Signature of person to whom delivery is made.

16. An alphabetical register is also to be introduced to record particulars of kits inquired for by other ships and establishments of which no trace is found when the inquiry is made, in order that the inquiring ship or establishment may be immediately informed should the missing kit subsequently come to hand.

17. It is observed, from returns rendered in accordance with the instructions contained in Navy Order 216 of 1943, that unclaimed effects of ratings have been held in baggage stores at certain shore establishments for long periods. With a view to the disposal of these items, commanding officers of the establishments concerned are to arrange for a list of items held, setting out fullest information available as to ownership, to be prepared and forwarded as early as possible to the Commodore Superintendent of Training, Flinders Naval Depot, for advice as to the present appropriation of the ratings.

18. In cases where ownership of unclaimed baggage is not clearly indicated on the outside of the packages as required by standard instructions, or on the labels attached thereto, the packages are to be opened in the presence of a responsible officer and the contents examined for any information which might lead to ownership being determined. A list of the contents of each package opened is to be prepared on Form A.S.98 or A.S.98A and placed in the container. This list must be signed by the officer in whose presence the package was opened who will certify as to the contents disclosed on opening the package, place of examination and reason for inspection of contents. The package should then be securely fastened and a label attached thereto setting out all information available as to ownership.

19. In future, baggage of personnel is not to be finally stowed in a baggage store unless ownership is clearly indicated and it is known that the stowage of such baggage is authorized. When baggage is

received and the whereabouts of the owner are unknown, packages are to be kept under review pending definite advice as to disposal. Should no advice be received within a reasonable period, the Commodore Superintendent of Training, Flinders Naval Depot, is to be contacted in the matter with a view to the items being restored to the rightful owner with a minimum of delay, or in the case of a rating who has been discharged "Run," "S.N.L.R.," "Dead," &c., disposed of as set forth in the relevant Regulations and Instructions.

20. A Return of unclaimed effects of personnel held in baggage stores at shore establishments is to be rendered quarterly to the Director of Victualling, Navy Office, Melbourne (copy to the Commodore Superintendent of Training, Flinders Naval Depot), i.e., on 1st January, 1st April, 1st July and 1st October each year. It is important that these returns be forwarded as early as possible after the due date. "Nil" returns are required.

21. C.O.R., Article 407, Navy Orders 57, 216 and 677 of 1943, and Article 243, clause 3, Naval Financial Regulations and Instructions, are hereby cancelled.

(516/201/552.)

RESTRICTED.(FOR OFFICIAL USE ONLY.)

Commonwealth Navy Orders.

Navy Office, Melbourne,
3rd July, 1945.

The following Orders, having been approved, are hereby promulgated for information and guidance and necessary action.

By direction of the Naval Board,

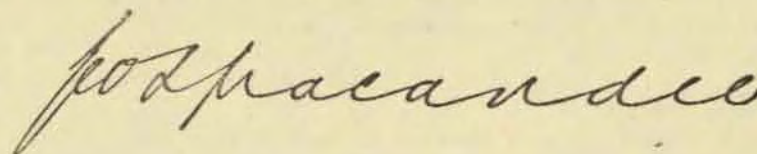

Secretary.

*The Commodore Commanding H.M.A. Squadron,
and Commanding Officers of H.M.A. Ships,
Officers in Charge of H.M.A. Naval
Establishments, and others concerned.*

TABLE OF CONTENTS.

No.	Subject.
265.	R.A.N. Destroyers—British Pacific Fleet Supply Office.
266.	Organization of Sydney Command—Status of Gunnery Instructional Centre.
267.	Acting Q.R.1s (S.V.).
268.	Propeller Shafting—Repair by Welding.
269.	Palmer LLH Petrol Engines—Operating Speeds.
270.	Fumigation of H.M.A. Ships.
271.	Lifeboat First Aid Equipment—Scale “H.”
272.	Life Raft First Aid Equipment—Scale “G.”
273.	Lifting Appliances on H.M.A. Ships—Label Plates.
274.	Consignment of Naval Armament, Gunmounting and Torpedo Stores by Rail.
275.	Books and Forms.
276.	Department of the Navy—Vacancies.

265.

R.A.N. DESTROYERS—BRITISH PACIFIC FLEET SUPPLY OFFICE.

The accounts of 7th Destroyer Flotilla, British Pacific Fleet, H.M.A. Ships *Napier*, *Nepal*, *Nizam*, and *Norman*, and of the 4th Destroyer Flotilla, H.M.A. Ships *Quiberon* and *Quickmatch*, are carried in H.M.A.S. *Napier*, with Supply Officer located ashore in Room 1004, 10th Floor, Barrack House, Barrack-street, Sydney. Telephone No. is BO539; Extension 176.

2. The address for correspondence and signals is:—

(a) Correspondence—

Supply Officer,

R.A.N. Destroyers,

British Pacific Fleet,

Fleet Mail Office, Sydney, New South Wales.

(b) Signals—

S.O., R.A.N. (D), B.P.F.

3. The arrangements under which these Destroyers are transferred to the R.A.N., for manning purposes, and the apportionment between Admiralty and the Commonwealth of financial liability for their maintenance are set forth in C.A.F.O. 2006/43 and Confidential Commonwealth Navy Order 51 of 1944.

4. Should any cash advances be made to these ships from an Australian source, the expenditure is to be charged to Division 203—Recoverable Expenditure (Admiralty)—(A)—Pay; the advance being transferred to Supply Officer, R.A.N. Destroyers. Navy Office is to be advised of any such advances made, *vide* Naval Account Regulations and Instructions, Article 178.

5. Navy Order 180 of 1945 is cancelled.

(401/211/1340.)

(1804/2/184.)

266.

ORGANIZATION OF SYDNEY COMMAND—STATUS OF GUNNERY INSTRUCTIONAL CENTRE.

The Gunnery Instructional Centre, Sydney, is being commissioned as H.M.A.S. *Mindari* with accounts carried in H.M.A.S. *Rushcutter*. The title "Officer-in-Charge, Gunnery Instructional Centre, Sydney," will be altered to "Commanding Officer, H.M.A.S. *Mindari*."

2. The responsibilities of the Commanding Officer, H.M.A.S. *Mindari* are—

(a) D.E.M.S. gunnery training;

(b) the gunnery training and efficiency of all minor war vessels operating under the Flag Officer-in-Charge, Sydney;

(c) providing facilities for the training of fleet units and minor war vessels visiting, and refitting in, Sydney.

3. The Commanding Officer, H.M.A.S. *Mindari* is at present also appointed as Port Gunnery Officer, Sydney. His additional responsibilities in this capacity remain unchanged.

(549/201/137.)

267.

ACTING Q.R.1's (S.V.).

The non-substantive rating of Acting Q.R.1 (S.V.) may be granted to chief petty officers, petty officers or leading seamen carrying out the duties of gunnery instructors at:—

(a) Gunnery instructional centres.

(b) D.E.M.S. centres.

(c) Shore establishments where employed as gunnery instructors owing to the shortage of gunners' mates.

The badge to be worn is that of a Q.R.1.

2. Acting Q.R.1's (S.V.) are eligible for the non-substantive rate and pay of 1s. 6d. per diem:—

(i) If they have completed successfully a special instructor's course at the R.A.N. Gunnery School, Flinders Naval Depot, and passed an examination for which they have been granted a certificate, and while carrying out the duty of a gunnery instructor, or gunner's mate, allowed on complement.

(ii) With the approval of the Naval Officer-in-Charge, on the recommendation of the gunnery officer, while carrying out the duty of gunnery instructor or gunner's mate allowed on complement without possessing the certificate from the Gunnery School. The names of these ratings should be reported to the Naval Officer-in-Charge, Flinders Naval Depot, so that they can be drafted in for course when reliefs are available.

(iii) When allocated to a specific duty, which is considered to justify the non-substantive rate of Q.R.1. Approval for rate and pay is, in this case, to be obtained from the Naval Board.

3. The non-substantive pay of 1s. 6d. per diem is not payable concurrently with other gunnery allowances or training allowances.

4. The non-substantive rating of Acting Q.R.1 (S.V.) may be granted to ratings qualified in accordance with paragraph 2 above with retrospective effect to 1st July, 1943, but not earlier.

5. The grant of the non-substantive rating of Acting Q.R.1 (S.V.) and date of ceasing to be employed as such in a vacancy in complement is to be reported on Form A.S. 161 in every case.

(349/25/370.)

(This Order will be reprinted for posting on Notice Boards.)

268.

PROPELLER SHAFTING—REPAIR BY WELDING.

In order to limit the deterioration of propeller shafting by corrosion, it has been decided that repairs by welding will be permitted on shafting of 28/32 ton steel.

2. Unless it is reasonably certain that the shafting is in good condition, it is to be thoroughly cleaned as soon as practicable after docking and an examination made to determine the extent to which repairs are desirable.

3. Isolated pitting in excess of about 3/16 inch in depth may be repaired by welding *in situ*, the welding being dressed off flush with the body of the shaft after completion. When such repairs are carried out, a report with sketches is to be forwarded to the Naval Board for information.

4. Where extensive pitting is found in circumferential bands such that the cross section of the shaft is appreciably reduced, it will be necessary for the shafting to be withdrawn, and for the defective area to be turned down to sound metal and completely re-built by welding. The length of shaft machined must be sufficient to allow longitudinal runs of welding to be deposited in the "N.S.E.W." method and must not be less than 12 inches.

5. As this procedure requires special welding technique, and since there are limits beyond which the diameter must not be reduced by turning, Naval Board approval is to be sought by signal before such repairs are made. The signal should state the location of the defects, the approximate area affected and the minimum diameter to which it would be necessary to machine the shaft to remove the band of pitting.

6. Welding repairs to shafting of 34/38 ton steel (as fitted in modern cruisers and destroyers) will not be permitted for the present.
(656/201/312.)

269.

PALMER LLH PETROL ENGINES—OPERATING SPEEDS.

Reports of excessive engine wear have been received from frigates and other ships carrying motor boats fitted with the Palmer LLH Engine.

2. It appears that a contributory cause of this trouble is the over-speeding of the engine which may arise from the unavoidable use of high octane motor spirit in forward areas.

3. In order to minimize trouble from this cause, arrangements should be made in boats concerned for the fitting of a stop pin in the throttle quadrant in such a position as to limit the maximum speed of the engine, when using high octane spirit, to 1650/1700 R.P.M.

4. The stop pin should be arranged so that it may be removed when normal grades of fuel are in use.
(603/293/987.)

270.

FUMIGATION OF H.M.A. SHIPS.

Medical journals recently received in Navy Office disclose a considerable increase of infestation by rats and also in some cases by fleas, bugs, etc., in H.M.A. ships,

2. It appears hardly necessary to point out the very grave danger of rat infestation in the case of H.M.A. ships operating in or arriving from areas where plague is endemic or where sporadic cases may, from time to time, occur showing that the rat population is affected by the bacillus of plague.

3. The only satisfactory method of eliminating rats is by complete fumigation of the whole ship. This procedure is to be carried out at the earliest possible opportunity by any of H.M.A. ships in which rats have been observed and especially if the ship has returned from areas referred to in the foregoing paragraph.

4. Commanding officers are to ensure that an item for fumigation is inserted in the ship's main defect list for annual refits or more frequently if considered necessary.

5. Special care is also to be taken in regard to the provision of adequate rat guards and in the disposal of garbage when alongside.

6. In cases of doubt, the representative of the Commonwealth Department of Health should be consulted.
(653/201/54.)

271.

LIFEBOAT FIRST AID EQUIPMENT—SCALE "H."

This equipment is now ready for issue from the Medical Store, Hereford-street, Glebe, New South Wales, to whom demands in quintuplicate should be forwarded. The set is to be known as Scale "H."

2. One set per lifeboat is to be drawn.

3. The set is sealed and consists of the following items. First aid instruction for lifeboats should conform to this standard.

Acid tannic burn jelly, 4-oz. tubes	4 No.
Morphia or omnopon syrettes	36 No.
Iodine tincture, 1½-oz. bottle	1 No.
Eye drops—cocaine in castor oil	1 oz.
Sulphanilamide in 3-oz. shaker	1 No.
Mosquito repellent lotion, 4-oz. bottle	1 No.
Ointment boracic acid, 4-oz. tube	4 No.
Tablets oral atebrian	100 No.
Tablets oral energy (benzedrine)	50 No.
Tablets solution acriflavine	50 No.
Eye dropper—glass—in tin	2 No.
Measure glass—medicine—1 oz.	1 No.
Bandages W.O.W., 1 inch	12 No.
Bandages W.O.W., 2 inches	12 No.
Bandages W.O.W., 3 inches	12 No.
Bandages triangular	6 No.
Lint absorbent, 4-oz. packets	1 pkt.
Plaster adhesive, 3 inches	5 yds.
Shell dressings	12 No.
Wool, cotton, absorbent	8 oz.
Forceps splinter	1 No.
Scissors counter, 8 inches	1 No.
Tourniquet, Samway, 3 feet	1 No.
Box, bondwood, steel bound, containing above in sealed carton	1 No.

4. Spare sets above actual requirements are not to be demanded as stocks are insufficient to meet other than first supply.

5. These sets are not to be drawn for lifeboats as they are not sufficiently waterproof. Scale "G" is designed for lifeboats.
(612/213/2724.)

272.

LIFE RAFT FIRST AID EQUIPMENT—SCALE "G."

This equipment is now ready for issue from the Medical Store; Hereford-street, Glebe, New South Wales, to whom demands, in quintuplicate, should be forwarded. The set is to be known as Scale "G."

2. One set per 10-man raft and two sets per 20-man raft or above are to be drawn.

3. The set consists of rubber joint, crimp sealed, ring tear opening tins, numbered 1, 2, 3 and 4, and a waterproof package of cramer wire splinting. The tins are designed to fit in the ends of the wooden grating of the Carley float, and the parcel of splints under the middle cross bar.

4. The tins have the contents printed on the outside in order that the desired tin only need be opened as and when necessary. No instruments are necessary to open the tins or apply the contents.

5. The contents of the tins are as shown hereunder, and instruction in their use should conform to this standard.

Tin No. 1—

First field dressing	1 No.
Acid tannic burn jelly, $\frac{3}{4}$ oz.	3 tubes
Shell dressing	1 No.

Tin No. 2—

Shell dressings	2 No.
Mosquito repellent lotion	4 oz.

Tin No. 3—

Shell dressing	1 No.
First field dressing	1 No.
Tourniquet, Samway, 3 feet	1 No.

Tin No. 4—

Tourniquet, field	1 No.
Triangular bandages	2 No.
Morphia or omnopon syrettes	4 No.
Acid tannic burn jelly, $\frac{3}{4}$ oz.	2 tubes
Eye drops—cocaine in castor oil	1 oz.
Wax matches—watertight bottle	1 No.
Vaseline, $\frac{3}{4}$ oz.	1 tube
Energy tablets (benzedrine)	50 No.
Atebrin tablets (daily dose)	100 No.

Parcel—

Cramer wire splints, 15 in. x 3 in.	2 pieces.
--	-------	-----------

6. Spare sets above actual requirements are not to be demanded as stocks are insufficient to meet other than first supply.

7. These sets are not to be drawn for lifeboats, for which Scale "H" is available.

(612/213/2590.)

273.

LIFTING APPLIANCES ON H.M.A. SHIPS—LABEL PLATES.

A recent accident to a derrick, which was being used to lift a load in excess of the authorized working load, has drawn attention to the necessity for fixing suitably engraved label plates to all lifting appliances on H.M.A. ships so that ships' officers will have this information immediately to hand. This applies especially to derricks and davits.

2. Fitting out authorities are in all cases to ensure that these plates are fixed in a prominent position to derrick posts and davits. A typical layout is shown below:—

Working load not to exceed	3 tons
Running Test	4 $\frac{1}{2}$ tons
Static Test	6 tons
Date of last test.....	
Initials of Testing Officer.....	

3. This layout is applicable to R.A.N. ships. For merchant vessels taken up for service and for vessels where the lifting appliances are tested in accordance with Regulations under the Navigation Act, layout should be as under:—

Working load not to exceed.....	tons.
Proof Load *	tons.

The figure for the proof load at * will vary in accordance with the working load of the derricks as follows:—

<i>Safe Working Load.</i>	<i>Proof Load.</i>
Up to 20 tons	25 per cent. in excess.
20 to 50 tons	5 tons in excess.
Over 50 tons	10 per cent. in excess.

4. Label plates in general should be about 6 in. x 4 in. and secured to the derrick post or davit with $\frac{1}{4}$ -in. screws. Care is to be taken that screw holes are not drilled in highly stressed positions. Plates are to be renewed as necessary upon all subsequent periodical testings, and are to be kept unpainted.

5. As an additional safeguard, derrick booms are to have painted upon them a bold inscription "WORKING LOAD IS NOT TO EXCEED.....TONS."

(2026/2/900.)

274.

CONSIGNMENT OF NAVAL ARMAMENT, GUNMOUNTING AND TORPEDO STORES BY RAIL.

Consignments of non-explosive naval armament, torpedo and gunmounting stores by rail for the Naval Officer-in-Charge, Port Melbourne; Naval Depot, Williamstown; Armament Depot, Maribyrnong, and H.M.A. and D.E.M. Ships at Victorian Ports, should be consigned to the Deputy Armament Supply Officer, Dynon-road Siding, Melbourne, when forwarded by goods train and to the Deputy Armament Supply Officer, Ordnance Factory, Maribyrnong, when forwarded by passenger train.

2. Consignments of one or more truck loads of explosive stores should be consigned to the Deputy Armament Supply Officer, Somerton Siding. Consignments of less than one truck load of explosives should be consigned to the Deputy Armament Supply Officer, Ravenhall Siding.

3. Consolidated Orders and Regulations, Article 531 (b), clause 5, will be amended accordingly.

(631/201/1073.)

275.

BOOKS AND FORMS.

First supplies of the under-mentioned publications have been distributed:—

B.R.214/1944.—Drill for 4.7 in. Q.F. Marks IX and IX* Guns, on C.P. XIV and XVII Mountings.

(A.F.O. 5703/44.)
(571/202/2131.)

B.R.268 (41).—Electrical Manual, Volume II—Trough Platform System of Leading Electric Cables into Turrets and Gun Mountings.

(A.F.O. 6221/44.)
(571/202/2040.)

B.R.299/1944.—Hand book for Signalling Equipment (other than V/S) fitted in H.M. Ships.

B.R.299A/1944.—Hand book for Signalling Equipment (other than V/S) fitted in Requisitioned Ships.

(A.F.O. 474/45.)
(571/202/2066.)

Errata No. 1 to B.R.321.—Establishment of Naval Stores for Engineering Purposes.

(A.F.O. 5355/44.)
(571/202/1890.)

B.R.640 (30).—Combined Operations Pamphlet No. 30—Employment of Amphibians.

(A.F.O. 1112/45.)
(571/202/1837.)

B.R.648/1944.—Drill for 2 pdr. Mark VIII Guns on Marks VI_A and V_A (Plain and R.P.C.) Mountings.

(A.F.O. 6223/44.)
(571/202/2142.)

B.R.791/1944.—Wireless Signalling Instructions.

(A.F.O. S.334/44.)
(571/202/2036.)

B.R.867.—Handbook and Drill for the 20-mm. Oerlikon Guns, Mark II on Twin Mark V (Powered) Mounting.

(A.F.O. 1277/44.)

B.R.867 (1).—Addendum No. 1 to above.

(A.F.O. 5595/44.)
(571/202/1958.)

B.R.990.—Fundamental Principles of Ionospheric Transmission, Part 1.

(A.F.O. 3891/44.)
(571/202/2069.)

B.R.1050c.—Fishing and Trading Craft of the Netherlands East Indies, New Guinea and the Solomon Islands.

(A.F.O. 6341/44.)
(571/202/2114.)

B.R.1209.—Pamphlet for 3-in., 50-cal. Fire Control Equipment and arrangements for American Built D.E.'s and P.F.'s.

(A.F.O. 4825/44.)
(571/202/2055.)

B.R.1210.—Booklet on Welfare Services in the Royal Navy.

(A.F.O. 5830/44.)
(571/202/2095.)

O.U.6353.—British Merchant Vessels Lost from Outbreak of War—August, September, October, November and December, Supplements and Amendments.

O.U.6353A.—Foreign Merchant Vessels Sunk and Damaged by the Enemy from Outbreak of War—August, September, October, November and December, Supplements and Amendments.

(A.F.O.'s. 6226 and 6771/44 and 1490/45.)
(571/203/2460.)

W.1/M.350.—Optimum Frequency Band Tables.

W.2/M.350.—Frequency Guide for the Atlantic Ocean and Mediterranean Zone Scheme.

W.3/M.350.—Frequency Guide for the Indian Ocean and Mediterranean Zone Scheme.

W.4/M.350.—Frequency Guide for Shore-Ship Communication in the Indian Ocean.

W.5/M.350.—Frequency Guide for Stations keeping Watch on U.S. Ship-Shore Frequencies.

(A.F.O. 6098/44.)
(571/202/2016.)

A.R.Mat/1930.—Photographs of Russian Aircraft Sets No. 1 to 11.

(415/201/1967.)

S.1700.—Aircraft Recognition Photographs Sets numbered from Nos. 20 to 26 inclusive.

S.1700.—Aircraft Recognition Photographs Sets containing pages numbered 51 to 57, 59 to 61, 64, 66 to 71, 73, 76 to 79 and 84 to 88.

(480/202/4706.)

A.P.3032.—R.A.F. Signal Manual—Part III Signalling Procedure.

(571/201/4620.)

2. The following books are cancelled and all copies are to be disposed of in accordance with the instructions contained in B.R.1, viz.:

B.R.317 (8).—Mining Drill Book—Preparation of the Mark XXVII Mine Asy. Nos. 1, 2, 3, 4.

B.R.317 (11).—Mining Drill Book—Preparation of the Mark XIX Sinkers Asy. Nos. 1, 2.

(A.F.O. 1110/45.)
(571/202/1970.)

Army Training Memorandum (War) Australia No. 39.

(546/201/443.)

American Warship Silhouette Charts Nos. 1 to 7.

(571/201/4597.)

Large Wall Silhouettes—Issue I, May, 1944. "Sally" Mark III Bomber.

Aircraft Silhouettes (Large Wall Size) Issue No. 1 Sep./44 and Issues Nos. 1 and 2, October and November, 1944.

3. The under-mentioned forms have been adopted for use in the R.A.N. First Supply will be effected, without demand, by the Superintending Naval Store Officer, Sydney.

S.285A.—Magazine Log, Part II (S) (Cruisers only).

(A.F.O. 4825/43.)
(480/202/3885.)

S.1204.—Report on Air Interception measures, against Enemy Aircraft, Surface Craft and Submarines.

(A.F.O. 2409/44.)
(480/202/4616.)

S.1562.—Regulations for Watertight Openings.

(C.A.F.O. 1340/43.)
(480/202/4541.)

DEMS 15 (c).—D.E.M.S. Defect Book and Record of Equipment and Ammunition.

(A.F.O. 6224/44.)
(480/201/3545.)

O.414 (g).—History Sheet for Torpedo or Paravane—Request Form.

(A.F.O. 3353/44.)
(480/201/3437.)

4. The under-mentioned form has been introduced for use in the R.A.N. in lieu of the corresponding Admiralty Form. Supply will be effected on demand by the Superintending Naval Store Officer when stock of the existing form is exhausted.

A.S.285(f).—Magazine Log.

(480/202/4690.)

5. The under-mentioned form has been revised. On receipt of first supply, which will be effected, without demand, by the Superintending Naval Store Officer, Sydney, the existing form will be rendered obsolete.

A.S.1303A.—List of Men Recommended to Qualify for V/S or W/T Non-substantive Ratings.

(480/202/4721.)

6. The under-mentioned form has been adopted for use in the R.A.N. and supersedes Forms S.1512A and B and RPS 14A and B. Supply will be effected, without demand, by the Superintending Naval Store Officer, Sydney, to Naval Control Service Officers at Merchant Ships' Books Distributing Ports.

S.1512/RPS 14c.—Allowance of Registered Publications.

(A.F.O. 5494/44.)
(480/202/4678.)

7. The under-mentioned form has been adopted for use in the R.A.N. First Supply will be effected, on demand, by the Superintending Naval Store Officer, Sydney.

D.742A (S.235).—Return showing action taken in connexion with the Issue and Receipt on Change of Condition of Spare Gear, &c.

(A.F.O. 5601/44.)
(480/201/3494.)

276.

DEPARTMENT OF THE NAVY—VACANCIES.

Applications have been invited from persons desirous of temporary appointment to this Department in a civil capacity as Clerks for duty in connexion with the audit of Naval Store Accounts and stocktaking duties. Vacancies exist at H.M.A. Naval Establishments, Sydney, for the under-mentioned positions:—

(a) Temporary position of Clerk, Assistant to Officer-in-Charge, Audit Section, Naval Store Branch, Sydney. Actual commencing salary including Cost of Living Allowance

(at present £40 per annum) will be between £418 and £490 per annum and will be determined according to qualifications and experience of the appointee.

- (b) Temporary position of Clerk, Stocktaking Duties, Naval Store Branch, Sydney. Actual commencing salary including Cost of Living Allowance (at present £40 per annum) will be between £382 (£394 if returned soldier or member of a Union) and £454 per annum and will be determined according to qualifications and experience of the appointee.

2. Applications, stating age, qualifications and experience (particularly in respect of accountancy and audit work), present employment and particulars of any service in the Naval, Military or Air Forces, will be received by the Director of Civil Personnel, Department of the Navy, Melbourne, S.C.1, from whom full particulars may be obtained, until 12th July, 1945. Copies of testimonials should be enclosed with applications.

(712/205/474.)

RESTRICTED.

(FOR OFFICIAL USE ONLY.)

Commonwealth Navy Orders.

Navy Office, Melbourne,
10th July, 1945.

The following Orders, having been approved, are hereby promulgated for information and guidance, and necessary action.

By direction of the Naval Board,

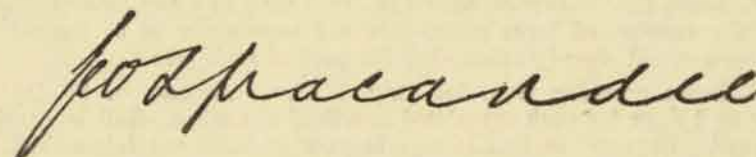

Secretary.

*The Commodore Commanding H.M.A. Squadron,
and Commanding Officers of H.M.A. Ships,
Officers in Charge of H.M.A. Naval
Establishments, and others concerned.*

TABLE OF CONTENTS.

No.	Subject.
277.	Leave—R.A.N. Women's Services.
278.	Landing Craft Signalmen (Sig. L.C.)—Institution of Higher Non-substantive rates.
279.	Advancement of Ratings Trained in Combined Operations.
280.	Higher Educational Test—April, 1945—Results.
281.	Signals Referring to Nursing Sisters.
282.	A.F.O. 106/1945: Advancement of Ratings—Prisoners of War on Repatriation.
283.	Bandsmen—Employment in lieu of R.C. Ratings—Allowance—A.F.O. 909/45.
284.	Chests Testing Sets for D.C. Pistols.
285.	Fire Precautions.
286.	Record of Interocular Distance.
287.	Naval Store Issuing Ship—Supply of Naval Stores for Escort Vessels in the Northern Area.
288.	Naval Stores—Interstate and Overseas Shipments and Consignments by Rail and Air Freight to Naval Establishments in Victoria.
289.	Life-saving Equipment—Red Reflector Discs—Introduction.
290.	Port Directors.
291.	Communication Wavemeter Outfits.

C.6550/45.

277.

LEAVE—R.A.N. WOMEN'S SERVICES.

The following instructions, which are to govern the grant of recreation leave, leave without pay and leave on compassionate grounds to present serving members of the Women's Royal Australian Naval Service and the Royal Australian Naval Nursing Service are promulgated for information and guidance. Previous instructions in this regard are cancelled.

Recreation Leave.

2. Recreation leave and travelling leave may be granted to members of the R.A.N. Women's Services in accordance with the conditions prescribed for members of the sea-going forces.

3. Recreation leave is to be calculated on the basis of 24 days a year plus necessary travelling time.

4. Leave for the current year (24 days) may be taken as convenient, and the amount of leave granted is not necessarily to be limited to the leave credit already established for part of such year.

5. Leave accruing from 1st July, 1942, at the rate of 24 days a year or 2 days for each completed month if not taken, shall be carried forward. Payment in lieu of any balance of leave not taken shall be made after final discharge.

6. Home leave passes but *not* leave concession warrants may be issued.

Compassionate Leave.

7. Subject to the conditions set out in paragraphs 8-12, both inclusive, of this Order, naval officers-in-charge or commanding officers may grant leave on compassionate grounds with full pay plus necessary travelling time without prior reference to the Naval Board.

8. The grounds for grant of compassionate leave (which is to be regarded as a privilege and not a right) shall be as follows:—

(a) Death, imminent death or dangerous illness of husband, child or parent, or other near dependent relative;

(b) urgent private reasons of an exceptional or personal nature not connected with the immediate resumption of civil employment. Cases of serious prejudice in business, domestic or financial affairs of a member shall be considered as a legitimate ground for granting compassionate leave only when the member's presence will materially affect the situation. Marriage is not a ground for the grant of compassionate leave.

9. The amount of leave so granted to a member (which shall be confined to that which is absolutely necessary) shall be subject to a maximum period of full pay of 28 days exclusive of the requisite travelling time on each such occasion and shall be apportioned as follows:—

(a) The first 7 days (or portion thereof where the period is less than 7 days) shall be treated as compassionate leave and shall not be debited against recreation leave.

(b) Any further period shall be treated strictly in the following order, as:—

(i) a debit against recreation leave at credit up to the end of the current leave year;

(ii) a debit, up to eight days only, against recreation leave to accrue in the next leave year;

(iii) additional compassionate leave.

10. Where an extension of such leave is required beyond the maximum of 28 days or where leave is required for reasons other than those specified in paragraph 8 and recreation leave for the current year has been exhausted, such leave shall be without pay and granted in accordance with paragraphs 13-18, both inclusive, of this Order.

11. It shall be the responsibility of the commanding officer to inquire into the circumstances of each application for the grant of compassionate leave and, if practicable, to obtain a certificate or other evidence which is to be forwarded to the Naval Board together with his report of the matter. This report is to include details of the apportionment of the leave in addition to full information of the compassionate circumstances warranting the grant of such leave.

12. Where it is necessary to avoid delay in dealing with an application for compassionate leave, such leave may in the first instance be debited against recreation leave and a corresponding credit allowed if and when the bona fides of the application is established.

Leave Without Pay.

13. Naval officers-in-charge may grant leave without pay on urgent private domestic grounds to members of the R.A.N. Women's Services, up to a maximum of 14 days plus necessary travelling time, in any period of 12 months, without prior reference to the Naval Board.

14. The grant of such leave is to be reported as early as practicable to the Secretary, Naval Board, by letter, advising the number of days granted and the date of commencement of the leave.

15. The necessary travelling time granted is to be without pay.

16. Where an application is made for leave without pay in excess of 14 days plus necessary travelling time, the prior approval of the Naval Board is to be obtained before such excess leave is granted.

17. Leave without pay will count as part of a member's period of service, but will not count towards seniority for promotion or advancement or towards the requisite qualifying time for eligibility for credit of deferred pay.

18. A member under 21 years of age shall be permitted to count periods of leave without pay towards the requisite qualifying time for the increased rate of active pay provided that, where any continuous period of leave so granted exceeds two calendar months, the period in excess thereof shall not be permitted to count.

278.

LANDING CRAFT SIGNALMEN (SIG. L.C.)—INSTITUTION OF HIGHER NON-SUBSTANTIVE RATES.

The provisions of A.F.O. 3499/44 have been adopted in the Royal Australian Navy with the following exceptions:—

(a) The 1st class rate will not be instituted at present.

(b) Standards of knowledge will be based on U.S. systems of signalling and will be as indicated below.

2. Landing craft signalmen, who qualified in H.M.A.S. *Assault*, will be regarded as holding the 3rd class rate.

3. It is intended that each Australian Landing Ship, Infantry, shall carry two landing craft signalmen, 2nd class. The scheme of complement will be amended in due course. Landing craft signalmen may be promoted to fill vacancies in higher non-substantive rating in their own ship.

4. The authority for promotion is the commanding officer. The rating's service certificate is to be noted, and the Commodore Superintendent of Training is to be informed by letter.

5. Courses for higher rate are to be conducted in the ships in which ratings are serving.

6. Standards of knowledge are to be as shown in the following table:—

SIGNALMEN (L.C.) STANDARDS REQUIRED.

Part 1.—Practical.

	Sig. L.C. 111.	Sig. L.C. 11.
Flashing Receiving ..	6 w.p.m. 90 per cent.	10 w.p.m. 90 per cent.
Flashing Transmitting ..	6 w.p.m. 85 per cent.	10 w.p.m. 85 per cent.
Semaphore receiving (hand flags) ..	10 w.p.m. 90 per cent.	18 w.p.m. 95 per cent.
Semaphore transmitting ..	10 w.p.m. 85 per cent.	18 w.p.m. 90 per cent.
W.T. Receiving ..	—	12 w.p.m. 90 per cent.
W.T. Transmitting ..	—	12 w.p.m. 85 per cent.
R.T. Operating ..	B.	A.

Part II.—Theoretical.

(a) *Books and S.Ps.*

Care and custody of S.Ps. and S.P. correction ..	D.	C.
G.S.B.* ..	D.	C.
Landing Craft Manoeuvring Signals (F.T.P. 211) ..	A.	A.
International Code, Vols. I and II ..	D.	C.
Wims, Vol. I ..	D.	C.
Combined operating signals (C.C.B.P.2) ..		

* Landing and landing-craft signals (p. 169) to be treated in greater detail.

Part II.—Theoretical—continued.

	Sig. L.C. III.	Sig. L.C. II.
<i>(b) General.</i>		
Colours of U.S. naval flags and pendants ..	C.	B.
Colours and single meanings of international code flags ..	C.	B.
Definitions—(F.T.P. 183, D.N.C. 5) ..	D.	C.
Alarm signal (air raid warning, &c.) in harbour ..	B.	A.
Care and maintenance of V/S and W/T equipment ..	D.	C.
<i>(c) Message Handling and Procedure.</i>		
Phonetic alphabet ..	A.	A.
Forms and parts of messages (D.N.C.5) ..	C.	B.
Precedences (D.N.C.5) ..	B.	A.
V/S procedure (C.C.B.P.5) ..	C.	B.
International procedure ..	D.	D.
W/T procedure (C.C.B.P.1) ..	D.	C.
R.T. procedure (C.C.B.P.3) ..	B.	A.
Standard phraseology (D.N.C.5-7440) ..	C.	B.
<i>(d) Miscellaneous.</i>		
Rule of the Road, buoys, and beacons ..	D.	C.

The standards of knowledge A, B, C and D indicate—

A—Detailed knowledge.

B—Thorough working knowledge.

C—Working knowledge.

D—Elementary knowledge.

7. Navy Order 539 of 1943 is hereby cancelled.

(349/25/404.)

279

ADVANCEMENT OF RATINGS TRAINED IN COMBINED OPERATIONS.

The following conditions of service have been approved for ratings entered for, and serving in, the Combined Operations Organization.

2. Ordinary seamen required for combined operations training will be selected from ordinary seamen who have completed one month's disciplinary course at Flinders Naval Depot and will then be appropriated to combined operations camp as required. In view of the disadvantage to which these ratings will be subjected as compared with ordinary seamen who complete the full new entry course at Flinders Naval Depot and thus have the opportunity of gaining one month both in seamanship and gunnery, *vide* Navy Order 355 of 1941, the Naval Board have approved of the following conditions of advancement to able seaman of ordinary seaman selected for combined operations training:—

(a) On completion of the combined operations training course of two months, ordinary seaman may gain up to two months' time on examination in combined operations courses which include seamanship, boat work, small arms training, pilotage and signals, according to the scale:—

85 per cent. and over (V.G.I.)—two months.

75 per cent.—84 per cent. (V.G.)—one month.

74 per cent. and below—nil.

(b) Twelve months' service as ordinary seaman, including 4 months' sea service minus any time gained in accordance with (a). In exceptional cases, commanding officers may reduce the necessary service of an ordinary seaman to 11, 10 or a minimum of 9 months (in addition to time gained as at (a)), thus making possible a minimum of seven months' service. The due dates for advancement in all cases to be reckoned from the commencing date of service as ordinary seaman.

(c) An ordinary seaman, who has not completed four months' sea service including time allowed under paragraph 4, is only eligible to be advanced to acting able seaman on the completion of twelve months' service as an ordinary seaman. Confirmation and antedating in respect of time gained in accordance with (a) and (b) may be effected however on completion of four months' sea service.

(d) Ordinary seamen who may be returned to general service before completion of the two months' course referred to in (a) above will be subject to general service conditions of advancement. A maximum of one month's seniority for seamanship and one month for gunnery to be awarded by the commanding officer of the next sea-going ship under same conditions as if courses were completed in depot. Similarly ordinary seamen returned to general service after completion of training will be subject to general service conditions of advancement, unless such return was due to causes outside the rating's own control, in which case particulars should be reported to the Naval Board for decision.

3. Vacancies for leading seaman, leading signalman, leading telegraphist, leading stoker, petty officer, yeoman of signals, petty officer telegraphist, and stoker petty officer will be filled from personnel serving within the Combined Operations Organization and will be subject to the following conditions:—

To leading seaman, leading signalman, leading telegraphist, and leading stoker:—

(a) Authority of Naval Officer-in-Charge, Flinders Naval Depot.

(b) Vacancies in fleet numbers of combined operations organization.

(c) Recommendation on Form A.S.507 (owing to limited opportunities for confirmation a Form A.S.507 may be rendered for acting able seamen).

(d) No professional or time qualification.

(e) Advancement to be in the provisional acting temporary rating.

(f) Acting provisional temporary rating to be held only while serving in Combined Operations Organization including period up to 30 days whilst in hospital or on sick leave; ratings reverted to general service revert to the last confirmed substantive rating held.

To petty officer, yeoman of signals, petty officer telegraphist, and stoker petty officer:—

(a) As for leading seaman and leading stoker.

(b) Vacancy in fleet numbers of combined operations organization.

(c) Authority of the Naval Officer-in-Charge, Flinders Naval Depot.

(d) Recommendation on Form A.S.507. Recommendations are to include particulars of any civil employment or hobbies which may have contributed to the efficiency of the rating.

(e) Advancement to be in the provisional acting temporary rating.

(f) Acting provisional temporary rating to be held only while serving in Combined Operations Organization, including period up to 30 days whilst in hospital or on sick leave; ratings reverted to general service revert to the last confirmed rating held.

4. Combined operations ratings on shore abroad may count their shore service as sea time for advancement purposes, but other qualifications of a professional nature (whether examinations or certificates) may not be waived in connexion with general service advancement.

5. On completion of combined operations courses, a return of the results of the examinations is to be rendered to the Director of Navy Accounts and the Naval Officer-in-Charge, Flinders Naval Depot, setting out the percentages in various subjects and time gained by each rating. Names of ratings reverted to general service should also be indicated on this return.

6. Navy Order 649 of 1944 is cancelled.

(568/202/1008.)

HIGHER EDUCATIONAL TEST—APRIL, 1945—RESULTS.

The pass results obtained by candidates in the subjects taken by them in the Higher Educational Test held from the 10th to the 13th April, 1945, inclusive, are as given hereunder. Included in these results are the pass marks obtained by each candidate at previous examinations where such marks are higher than those obtained at the April, 1945, examination.

Name.	Rating.	Official No.	Where Serving at Time of Examination.	Papers.							Remarks.
				I.	II.	III.	IV.	VII.	VIII.	IX.	
				General Knowledge	English History	Geography	Navigation.	Practical Mathematics	Mechanics	Magnetism and Electricity.	
Ayers, Herbert M. ..	Ldg. Seaman ..	S/5287 ..	<i>Cerberus</i> ..	68		58		75			
Beit, Robert ..	Petty Officer ..	19658 ..	" ..					92			
Cathcart, John D. ..	Able Seaman ..	PM/7207 ..	" ..	83	64(xx)	63	70(xx)	76(xx)		85(xx)	Q.W.R. and H.E. Cert., 2nd Class
Lawrie, Stein R. ..	Able Seaman ..	S/7807 ..	" ..	80		58		84			
Lewis-Hughes, Joseph H. ..	Able Seaman ..	S/7808 ..	" ..	78		70					
McArthur, Gilbert J. ..	Able Seaman ..	S/8205 ..	" ..	68							
Robin, Hugh D. ..	Able Seaman ..	PA/4382 ..	" ..	69				94			
Sadler, Frank A. ..	Able Seaman ..	S/4053 ..	" ..	70				62			
Smith, William G. E. ..	Petty Officer ..	20903 ..	" ..			77					
Smith, William T. ..	Petty Officer Cook (O) ..	20410 ..	" ..				57				
Britten, Jeffrey N. H. ..	Petty Officer Writer ..	23514 ..	<i>Cerberus II.</i> ..	82	77	56					Q.W.R.
Goddard, George J. ..	Mech., 1st Class ..	19934 ..	<i>Hobart</i> ..	67(xx)		67(ss)		83(rr)	92(tt)	78(gg)	Q.W.R. and H.E. Cert., 2nd Class
McGregor, George A. ..	Chief E.R.A. ..	22098 ..	" ..	64(xx)	61			76			Q.W.R.
Smith, William A. ..	Reg. Petty Officer ..	20961 ..	" ..	70							Q.W.R.
Impey, Ronald S. ..	Petty Officer ..	22381 ..	<i>Kapunda</i> ..	70(vv)	63(vv)	78(uu)	64(vv)	64			Q.W.R. and H.E. Cert., 2nd Class
Thomas, Victor D. ..	Chief E.R.A. ..	20522 ..	<i>Kuttabul</i> ..	60	70	59					
Mason, Thomas K. ..	M.Mech., 4th Class ..	26230 ..	<i>Manoora</i> ..	68		65					
Barnes, Charles ..	Ordinary Seaman ..	PA/4750 ..	<i>Melville</i> ..					79			
Cummin, John D. ..	Petty Officer Tel. ..	19834 ..	" ..								
Chapman, Edward T. ..	E.Art., 3rd Class ..	S/6470 ..	<i>Nepal</i> ..	75(tt)	63(tt)	77(tt)	67(dd)	80(cc)	58	66	Q.W.R. and H.E. Cert., 1st and 2nd Class
Kerkin, Edward J. ..	C.P.O. Telegraphist ..	S/1632 ..	<i>Westralia</i> ..	61		63		77			
Potter, Edward T. ..	Telegraphist ..	F/2315 ..	" ..	63				70	57(wu)	78(wv)	H.E. Cert., 2nd Class

(cc) Marks obtained at March, 1934, examination.

(dd) Marks obtained at October, 1934, examination.

(gg) Marks obtained at April, 1936, examination.

(rr) Marks obtained at October, 1941, examination.

(ss) Marks obtained at April, 1942, examination.

(tt) Marks obtained at October, 1942, examination.

(vv) Marks obtained at April, 1943, examination.

(uu) Marks obtained at April, 1943, examination.

(ww) Marks obtained at April, 1944, examination.

(xx) Marks obtained at October, 1944, examination.

Maximum marks in each subject—100.

75 per cent. of total marks is considered a first class pass.

55 per cent. of total marks is considered a second class pass.

2. The marks obtained by candidates in subjects in which they did not pass are not shown above. Should any candidate desire to be informed of these marks, he should make application to the commanding officer of the ship or establishment, in which he is serving, who has been supplied with a statement of the full results.

(This Order will be reprinted for posting on Notice Boards.)

(465/204/674.)

281.

SIGNALS REFERRING TO NURSING SISTERS.

The attention of all commanding officers of ships and establishments is drawn to the necessity of repeating to the Naval Officer-in-Charge, Flinders Naval Depot, any signals or communications referring to members of the R.A.N. Nursing Service. This specially refers to communications concerning grant of leave or of temporary absence from place of duty in order to accompany sick patients or for any other reason.

(622/205/1862.)

282.

A.F.O.106/1945: ADVANCEMENT OF RATINGS—PRISONERS OF WAR ON REPATRIATION.

The provisions of A.F.O. 106 of 1945, with the exception of paragraph 6, are applicable to the Royal Australian Navy.

(568/202/1050.)

283.

BANDSMEN—EMPLOYMENT IN LIEU OF R.C. RATINGS—ALLOWANCE—A.F.O. 909/45.

The introduction of the radar control rating into the Naval Service has resulted in the allocation of certain of these ratings to some of the duties which have, in ships carrying a band, hitherto been carried out by bandmen.

2. The desirability of opening the Radar Control Branch to bandmen has been investigated, but, after careful consideration, the Naval Board have decided that such a step would not be in the best interests of the Naval Service.

3. It is the Naval Board's intention that, whenever practicable, band ratings should continue to be employed in transmitting stations on duties for which R.C. ratings are not allowed and that higher fire control allowance should continue to be paid on the present scales.

4. In ships where band, regulating, writer, stores, steward or cook ratings are filling a duty for which R.C. ratings are authorized and complemented, but not borne, an extension of the higher fire control allowance is hereby authorized on the following scales:—

For R.C. 2 duties 6d. a day.
For R.C. 3 duties 3d. a day.

(348/209/1.)

284.

CHESTS TESTING SETS FOR D.C. PISTOLS.

The following new items to be included in chests testing sets for D.C. pistols will shortly be distributed to all concerned:—

Tube testing St. No. 6554.
Ring I.R. St. No. 6599.
Stand assembly St. No. 6818.

2. On receipt of these items, the following items which will consequently become redundant are to be returned to the nearest Naval Armament Depot:—

Apparatus testing adjuster St. No. 6223.
Pump pressure water and hoses St. No. 6147.
Measure copper 1 oz. St. No. 6071.
Clips, pressure firing St. No. 6056.

3. Naval Armament Depots are to report to Navy Office on 31st August, 1945, stocks of the items referred to in paragraph 2.

(471/205/2615.)

285.

FIRE PRECAUTIONS.

The careless handling of petrol drums and the emptying of ullage petrol into an area adjacent to Naval Storehouses recently resulted in a fire causing considerable damage to buildings and stores.

2. The attention of all concerned is drawn to the necessity for observance of precautions against fire when handling volatile spirit and the fact that the decanting of petrol, &c. drums in the vicinity of buildings and stores is prohibited.

(475/201/210.)

286.

RECORD OF INTEROCULAR DISTANCE.

In future, the interocular distance of all executive officers and all seaman and communication ratings is to be measured on entry and notification made on (a) the medical history sheet and (b) the identity disc.

2. The interocular distance of all serving executive officers and of all seaman and communication ratings other than those with non-substantive rates is also to be measured and recorded as above.

3. This Order does not affect the recording of interocular distance on other documents as well—e.g., on the gunnery history sheet in the case of men at the ophthalmic examination for a gunnery non-substantive rating.

(527/201/1003.)

287.

NAVAL STORE ISSUING SHIP—SUPPLY OF NAVAL STORES FOR ESCORT VESSELS IN THE NORTHERN AREA.

H.M.A.S. *Whangpu* has been fitted as a Naval Store Issuing Ship and supplied with a comprehensive range of naval stores. The stocks carried are primarily to replenish escort vessels and M.L's but requirements of larger vessels will be met when necessary to the extent possible.

2. As from 19th June, 1945, demands for naval stores required by H.M.A. Escort Vessels, &c., in the vicinity of H.M.A.S. *Whangpu* should be lodged with the naval store issuing ship. Demands should be lodged at mainland bases or naval store depots only when it is impracticable owing to their location for escort vessels to draw requirements from the naval store issuing ship.

3. Demands for naval stores for these vessels at present held at bases or naval store depots will be supplied by the depot holding the demands and such items should not be re-demanded from the naval store issuing ship. When the vessels visit shore depots, the ship's store-keeping officer should take the opportunity to review and cancel as necessary outstanding demands.

4. All demands from H.M.A. ships for requirements of naval stores should be prepared on Forms A.S.134D and lodged in the naval store issuing ship in quadruplicate. In the case of periodical replenishments, the demands should be forwarded to the naval store issuing ship a reasonable period before the stores are actually required. It is necessary for all demands for consumable stores to show particulars of prior expenditure and stock held on the date of preparation of the demand and care should be taken to ensure that these particulars are included in order to avoid delay in satisfaction of demands. B.R.4, Article 14, refers.

5. Unserviceable naval stores returned to the naval store issuing ship for survey should be accompanied by a requisition for survey (Form A.S.331) and a demand (Form A.S.134D) for items required in lieu.

6. The procedure at present applicable to H.M.A. ships in regard to supply and return of naval stores at naval store depots is to be observed in regard to all transactions with the naval store issuing ship.

(612/226/1295.)

288.

NAVAL STORES—INTERSTATE AND OVERSEAS SHIPMENTS AND CONSIGNMENTS BY RAIL AND AIR FREIGHT TO NAVAL ESTABLISHMENTS IN VICTORIA.

With reference to paragraph 2 of Navy Order 35 of 1945, all interstate and intra-state shipments of naval stores forwarded to Melbourne for Navy Office; Flinders Naval Depot; Port Melbourne and Williamstown Naval Depots; the R.A.N. Mine Depot, Swan Island and H.M.A. Ships are in future to be consigned to the Officer-in-Charge, Naval Store Depot, Port Melbourne.

2. Consignments by goods and passenger rail and air freight to Flinders Naval Depot and the R.A.N. Mine Depot, Swan Island, are to be consigned direct to those establishments. Packages forwarded by rail and air freight for Navy Office; Port Melbourne and Williamstown Depots and H.M.A. Ships at Melbourne are to be consigned to the Officer-in-Charge, Naval Store Depot, Port Melbourne.

3. All consignments by sea or rail for the Naval Dockyard, Williamstown, are to continue to be consigned direct to the General Manager.

4. C.O.R., Article 531, Section (a), will be amended in R.I. Series in due course.

5. Navy Order 547 of 1943 is cancelled.

(612/201/5358.)

289.

LIFE-SAVING EQUIPMENT—RED REFLECTOR DISCS—INTRODUCTION.

With reference to A.F.O. 721/45, pattern 2034 red reflector discs will be issued in the R.A.N. Demands for requirements in accordance with the scale of allowances laid down in A.F.O. 721/45 should be forwarded to the Superintending Naval Store Officer, Sydney, as soon as possible by H.M.A. ships and naval establishments.

(612/231/381.)

290.

PORT DIRECTORS.

A Royal Australian Navy Port Director was appointed to Biak on 6th July, 1945.

(1937/2/302.)

291.

COMMUNICATION WAVEMETER OUTFITS.

It has been decided that certain H.M.A. ships and bases shall be supplied with modern communication wavemeter outfits, H.M.A. ships in accordance with the spirit of A.F.O. 4512/44 and bases with a modern outfit more portable than Admiralty Outfit GN.

2. An order has been placed for the necessary equipment which will be supplied, without demand, by the Superintending Naval Store Officer (R.A.N.), Sydney, in accordance with the following allocations:—

Wavemeter Outfit GN.—H.M.A. Cruisers, Destroyers (not including Tribal Destroyers which are already fitted with Outfit GH), Frigates, A.M.S. Vessels (except B.P.F. A.M.S. Vessels), L.S.Is. H.M.A. Ships *Stuart, Vendetta, Swan, Warrego, Moresby, Bungaree, Cerberus* (for H.M.A. Signal School), *Watson* and *Penguin* (for H.M.A. Signal Training Centre)—one outfit each.

Wavemeter Outfit GR.—H.M.A. Cruisers, H.M.A.S. *Watson*—one Outfit each.

U.S. Radio Equipment Model SCR 211 (Incorporating Wavemeter BC-211) Bases and Depot Ships for use by the W/T Officer.—Sydney, Brisbane, Townsville, Thursday Island, Madang, Darwin, Fremantle, Port Melbourne, Port Adelaide, H.M.A.S. *Platypus*—one equipment each.

For Instructional Purposes.—H.M.A. Ships *Cerberus* (for H.M.A. Signal School), *Penguin* (for H.M.A. Signal Training Centre) and *Watson*.

(612/246/3140.)

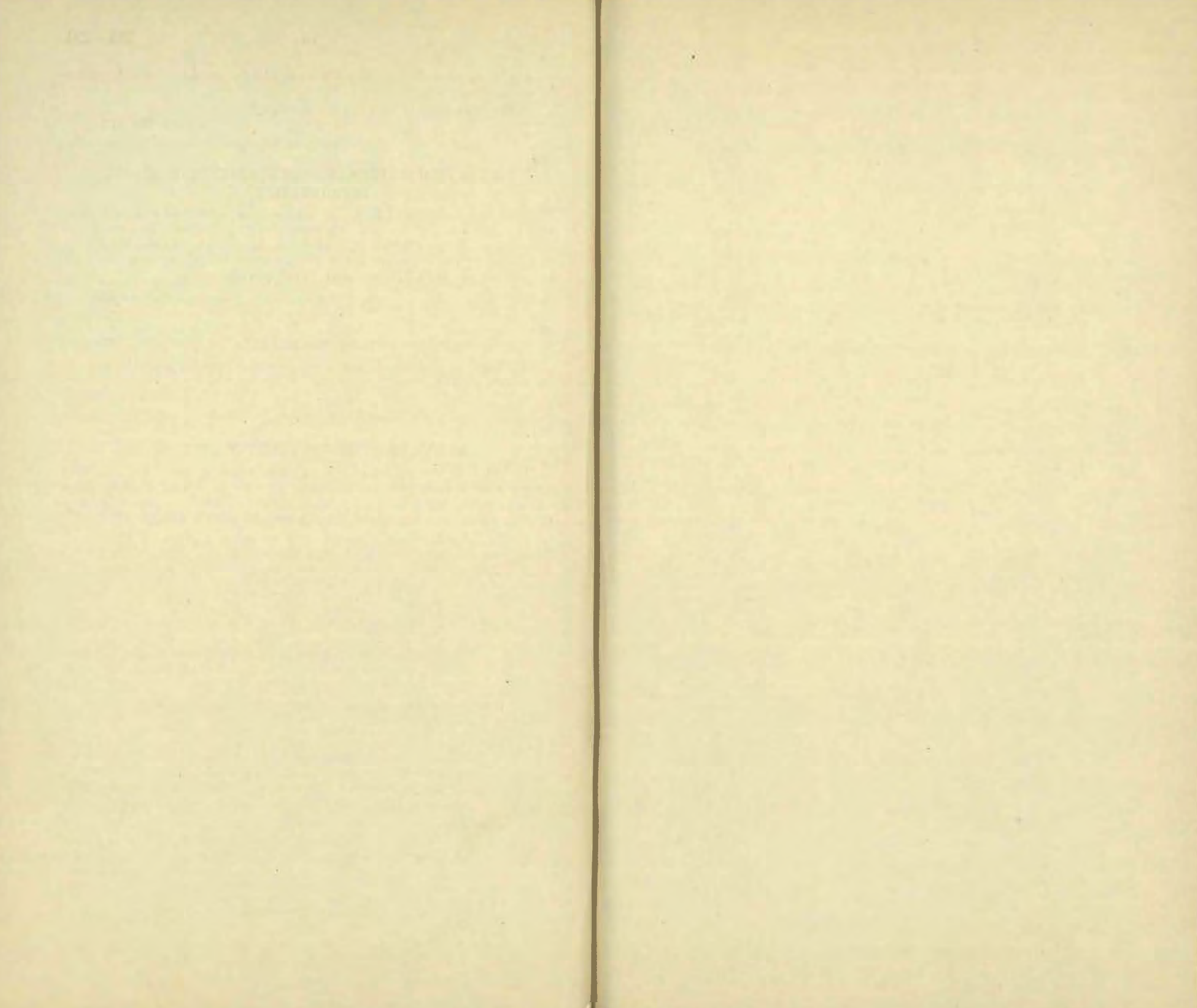

RESTRICTED.(FOR OFFICIAL USE ONLY.)

Commonwealth Navy Orders.

Navy Office, Melbourne,
17th July, 1945.

The following Orders, having been approved, are hereby promulgated for information and guidance and necessary action.

By direction of the Naval Board,

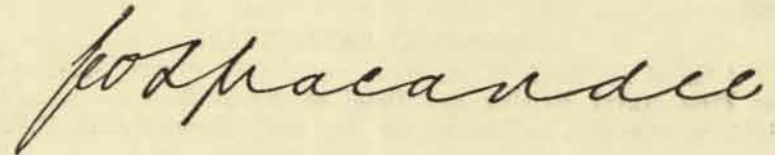

Secretary.

*The Commodore Commanding H.M.A. Squadron,
and Commanding Officers of H.M.A. Ships,
Officers in Charge of H.M.A. Naval
Establishments, and others concerned.*

TABLE OF CONTENTS.

No.	Subject.
292.	Admiral Sir Guy Royle, K.C.B., C.M.G.—Valedictory on Relinquishing Office as First Naval Member of the Naval Board.
293.	Changes in Naval Board.
294.	H.M.A.S. "Mindari."
295.	Naval Officer-in-Charge—Geraldton—Termination of Appointment.
296.	1939-45 Star.
297.	Postal Addresses—New Guinea Area.
298.	Class Advancement of Artificer and Artisan Branches.
299.	Examination of Engine Room Ratings—March, 1945.
300.	Educational Test I, March, 1945.
301.	Engine Room Ratings—Watchkeeping Certificates.
302.	W/T Equipment—Requisitioned Vessels—Maintenance of, by Amalgamated Wireless (Australasia) Ltd.
303.	Funeral Expenses—Payment of Press Notices.
304.	Establishment of Naval Stores for H.D.M.Ls.
305.	Restricted Issues of Fresh Milk and Milk Products.
306.	Naval Personnel Proceeding on Leave or Discharged—Supply of Cigarettes and Tobacco.
307.	H.M.A. M.Ls., H.D.M.Ls. and Air Sea Rescue Boats—Form A.D.495 (Report of Docking) and Form A.D.488 (Propellers and Underwater Fittings)—Procedure.
308.	Advice of Naval Stores Purchased—Marking of Ledger when Store Charge Certificate is given.
309.	Form A.S.542—Route Order and Travelling Expenses Claim.

292.

ADMIRAL SIR GUY ROYLE, K.C.B., C.M.G.—VALEDICTORY ON RELINQUISHING OFFICE AS FIRST NAVAL MEMBER OF THE NAVAL BOARD.

The following message has been received from Admiral Sir Guy Royle, K.C.B., C.M.G., on his relinquishing office as First Naval Member of the Naval Board:—

“In bidding farewell to the R.A.N., I wish to thank you all for your loyal help and co-operation during my four years in your great country. I have great hopes for the future of the R.A.N. which is an essential part of Australia's defence. I wish you all success.”

(443/202/279.)

293.

CHANGES IN NAVAL BOARD.

Admiral Sir Louis H. K. Hamilton, K.C.B., D.S.O., assumed duty as First Naval Member and Chief of Naval Staff on 29th June, 1945, in succession to Admiral Sir Guy C. C. Royle, K.C.B., C.M.G.

(404/202/974.)

294.

H.M.A.S. “MINDARI.”

H.M.A.S. *Mindari* (Gunnery Instructional Centre, Sydney), was commissioned on 1st July, 1945.

2. With reference to Navy Order 177 of 1943, H.M.A.S. *Limerick* has been renamed H.M.A.S. *Mindari*.

(549/201/179.)

295.

NAVAL OFFICER-IN CHARGE—GERALDTON—TERMINATION OF APPOINTMENT.

The appointment of the Naval Officer-in-Charge, Geraldton, was terminated on 20th June, 1945.

2. The Sub-Collector of Customs has resumed his normal duties as Admiralty Reporting Officer.

(2021/7/338.)

296.

1939-45 STAR.

Approval has been granted for the prolongation of the currency of the 1939-43 Star to the 8th May, 1945, the date of the end of active hostilities in Europe.

2. The conditions of award will otherwise remain as at present. (Navy Orders 466 of 1943 and 201 of 1944 refer.)

(448/201/1578.)

(This Order will be reprinted for posting on Notice Boards.)

297.

POSTAL ADDRESSES—NEW GUINEA AREA.

Delay in delivery of mails to New Guinea addresses is frequently caused by incorrect or incomplete addressing.

2. The following postal addresses for Royal Australian Navy Shore Establishments in the New Guinea area are promulgated for information. Amendments will be notified as necessary.

POSTAL ADDRESSES OF NEW GUINEA NAVAL SHORE ESTABLISHMENTS AND PORT DIRECTORATES IN NEW GUINEA AREA.		
<i>Naval Establishments, &c.</i>		<i>Postal Address.</i>
Aitape	Royal Australian Naval Port Director, Aitape.
Biak	Royal Australian Naval Port Director, Biak, Dutch New Guinea.
Hollandia	Royal Australian Naval Port Director, Hollandia.
Jacquinot Bay	Royal Australian Naval Port Director, Jacquinot Bay.
Lae	Royal Australian Naval Port Director, Lae.
Langemak	Naval Officer-in-Charge, Langemak.
<i>Madang</i> , H.M.A.S.	Commanding Officer, H.M.A.S. <i>Madang</i> .
Madang, Naval Officer-in-Charge	Naval Officer-in-Charge, Madang, New Guinea.
Madang, Naval Officer-in-Charge, New Guinea	Naval Officer-in-Charge, New Guinea, Madang.
Manus	Royal Australian Naval Liaison Officer, Manus.
Milne Bay	Royal Australian Naval Port Director, Milne Bay.
Mios Woendi	Royal Australian Naval Liaison Officer, Mios Woendi, Biak, Dutch New Guinea.
Morotai	Royal Australian Naval Liaison Officer, care of Port Director, Morotai.
Oro Bay	Royal Australian Naval Port Director, Oro Bay.
Torokina	Naval Officer-in-Charge, Torokina.
Wewak	Port Director, Wewak.

(1947/2/148.)

298.

CLASS ADVANCEMENT OF ARTIFICER AND ARTISAN BRANCHES.

Various requests have been received for approval to advance R.A.N.R., ratings of the artificer, shipwright and artisan branches to a higher class in less time than that required under the present regulations by virtue of their having been—

(a) advanced to 3rd class at an earlier date than usual under the then existing R.A.N.R. Regulations,

(b) entered in a higher class under the terms of Navy Order 276 of 1940, paragraph 10.

2. It is pointed out that the R.A.N.R. Regulations were "peace time" requirements for advancement and that a much higher standard and more actual service experience is required when mobilized.

3. Ratings receiving early advancement under (a) and (b) of paragraph 1 have been given the benefit denied to other members of their branches.

It is not, however, the intention that such benefits under (a) of paragraph 1 should be carried to subsequent advancements to a higher class, e.g., any rating advanced to the 3rd class after less service than that required by normal Regulations will have to serve the full combined time necessary for further advancement.

Similarly, a rating advanced under the conditions of (b) of paragraph 1 will have to serve the full time necessary for further advancement, irrespective of the actual time served in the next lower class.

(428/212/91.)

299.

EXAMINATION OF ENGINE ROOM RATINGS—MARCH, 1945.

The following results of examinations of engine room ratings are promulgated for information:—

O.N.	Name.	Present Rating.	Application Received From.	Result.
E.R.A. for C.E.R.A.				
Mechanician I. for Chief Mechanician.				
P.M/2742	Lawson, W. C. J.	E.R.A.3	<i>Kalgoorlie</i>	Passed satisfactory
F/3502	Johnson, G. A. . .	E.R.A.1	<i>Warrego</i>	Passed superior
24570	Braithwaite, T. S.	E.R.A.3	<i>Penguin</i>	Passed satisfactory
P.A/1345	Balnaves, I. J.	E.R.A.3	<i>Carpentaria</i>	Passed satisfactory
24361	Nelson, R. A. . .	E.R.A.3	<i>Carpentaria</i>	Passed satisfactory
P.A/1879	Heys, F. G.	E.R.A.3	<i>Moresby</i>	Passed satisfactory
S/5785	Fishburn, R. G.	E.R.A.3	<i>Moresby</i>	Passed satisfactory
23860	Sangwell, E. R.	E.R.A.3	B/D, Darwin	Passed superior
S/5065	Wilson, C. J. N.	E.R.A.3	B/D, Darwin	Passed superior
P.M/3779	Jones, R. V.	E.R.A.3	B/D, Darwin	Passed superior
P.M/3384	Byrne, J. D.	E.R.A.3	B/D, Darwin	Passed superior
P.M/2954	Tonnies, A. F. . .	E.R.A.3	B/D, Darwin	Passed satisfactory
19961	Dorsch, A. W. . .	Mech. 1	<i>Australia</i>	Passed satisfactory
21427	Dodd, L. J. C. . .	E.R.A.3	<i>Hobart</i>	Passed superior
H/1679	Armstrong, J. E.	E.R.A.3	<i>Hobart</i>	Passed satisfactory
23224	Norris, F. J. E.	E.R.A.3	<i>Bundaberg</i>	Passed satisfactory
24088	Bastion, R. D. . .	E.R.A.3	<i>Platypus</i>	Passed satisfactory
23744	Rich, W.	E.R.A.3	<i>Adelaide</i>	Passed satisfactory
24456	Bosci, F. B. . .	E.R.A.3	<i>Shropshire</i>	Passed satisfactory
E.R.A. (M) for C.E.R.A. (M).				
P.M/3383	Trevorrow, G. M.	E.R.A.3 (M)	<i>Southern Cross</i>	Passed satisfactory
P.M/1660	Wesson, T. B. . .	E.R.A.3 (M)	<i>Kanimbla</i>	Passed satisfactory

EXAMINATION OF ENGINE ROOM RATINGS—continued.

O.N.	Name.	Present Rating.	Application Received From.	Result.
E.R.A.A/4th Class for Confirmation.				
P.M/6790	Rouse, E. . .	E.R.A.A/4th	<i>Bendigo</i>	Passed satisfactory
P.M/6621	Glaister, J. . .	E.R.A.A/4th	<i>Warrnambool</i>	Passed superior
P.M/6620	Alexander, A. R.	E.R.A.A/4th	<i>Whang Pu</i>	Passed satisfactory
S/8340	Scott, J. H.	E.R.A.A/4th	<i>Tolga</i>	Passed satisfactory
P.M/6547	Vanderheiden, M. S.	E.R.A.A/4th	<i>Vendetta</i>	Passed superior
S/8860	Dirksen, W. C. . .	E.R.A.A/4th	<i>Vendetta</i>	Passed satisfactory
S/8947	Weidenhofer, K.	E.R.A.A/4th	<i>Vendetta</i>	Passed satisfactory
P.M/6623	Evans, W. M. . .	E.R.A.A/4th	<i>Warrego</i>	Passed satisfactory
F/5171	Merson, R. W. . .	E.R.A.A/4th	<i>Adelaide</i>	Passed superior
S/8663	Audit, R. A.	E.R.A.A/4th	<i>Rockhampton</i>	Passed superior
P.A/4257	Smith, E. F. C.	E.R.A.A/4th	<i>Latrobe</i>	Passed satisfactory
S/9093	Tharratt, L. J. . .	E.R.A.A/4th	<i>Gympie</i>	Passed superior
P.M/4131	Brumley, N. S. . .	E.R.A.A/4th	<i>Mildura</i>	Passed superior
S/3143	Tolland, A. . .	E.R.A.A/4th	<i>Hawkesbury</i>	Passed superior
S/8296	Sulter, H. V.	E.R.A.A/4th	<i>Hawkesbury</i>	Passed satisfactory
S/8883	Sutton, G. . .	E.R.A.A/4th	<i>Echuca</i>	Passed satisfactory
S/3371	Wilding, J. E.	E.R.A.A/4th	<i>Echuca</i>	Passed superior
S/9095	Vannan, T. S. . .	E.R.A.A/4th	<i>Pirie</i>	Passed satisfactory
S/7341	Kingston, A. M.	E.R.A.A/4th	<i>Pirie</i>	Passed satisfactory
W/1336	Smith, C. J.	E.R.A.A/4th	<i>Gladstone</i>	Passed superior
P.M/5002	Wood, T. V. . .	E.R.A.A/4th	<i>Gladstone</i>	Passed satisfactory
P.M/6249	Boulton, R. W.	E.R.A.A/4th	<i>Ladava</i>	Passed satisfactory
F/3932	Moffatt, H. B. . .	E.R.A.A/4th	<i>John Oxley</i>	Passed satisfactory
P.M/6881	Gordon, L.	E.R.A.A/4th	<i>Orara</i>	Passed superior
P.M/6548	McInerheney, T. F.	E.R.A.A/4th	<i>Stuart</i>	Passed satisfactory
B/4384	Crossman, L. W.	E.R.A.A/4th	<i>Stuart</i>	Passed superior
B/5385	Nash, R. W.	E.R.A.A/4th	<i>Stuart</i>	Passed superior
S/6930	Norris, R. E. . .	E.R.A.A/4th	<i>Penguin</i>	Passed satisfactory
P.M/6551	Searle, W. D. . .	E.R.A.A/4th	<i>Penguin</i>	Passed exceptional
P.M/6545	Virtue, K.	E.R.A.A/4th	<i>Penguin</i>	Passed satisfactory
S/6283	Bradshaw, R. . .	E.R.A.A/4th	<i>Bermagui</i>	Passed superior
S/6048	Luff, G. L.	E.R.A.A/4th	<i>Goolgwaai</i>	Passed satisfactory
B/4535	Glen, F. E. K. . .	E.R.A.A/4th	<i>Warramunga</i>	Passed superior
S/8943	Hansen, R. S. . .	E.R.A.A/4th	<i>Warramunga</i>	Passed superior
P.A/4378	Magor, A. E.	E.R.A.A/4th	<i>Warramunga</i>	Passed superior
P.M/6882	Gorrie, R. W.	E.R.A.A/4th	<i>Katoomba</i>	Passed superior
P.M/4302	Johnson, R. P. . .	E.R.A.A/4th	<i>Katoomba</i>	Passed superior
P.A/4033	Dare, R. J.	E.R.A.A/4th	<i>Shropshire</i>	Passed exceptional
P.M/6647	Howell, R. R. . .	E.R.A.A/4th	<i>Shropshire</i>	Passed satisfactory
P.M/4216	Cugley, J. K.	E.R.A.A/4th	<i>Shropshire</i>	Passed superior
P.A/4040	Bradley, J. E. . .	E.R.A.A/4th	<i>Shropshire</i>	Passed superior
P.M/6877	Malcolm, G. R. . .	E.R.A.A/4th	<i>Shropshire</i>	Passed satisfactory
B/4572	Cunningham, E. R.	E.R.A.A/4th	<i>Shropshire</i>	Passed exceptional
P.M/5947	Hunter, V. I. . .	E.R.A.A/4th	<i>Whang Pu</i>	Passed satisfactory
F/5065	Hood, W. G.	E.R.A.A/4th	<i>Mercedes</i>	Passed superior
S/3142	Harris, J. W. . .	E.R.A.A/4th	<i>Bangalow</i>	Passed superior
P.M/6462	De La Rue, C. J.	E.R.A.A/4th	<i>Horsham</i>	Passed satisfactory
P.M/6803	Souter, H. L.	E.R.A.A/4th	<i>Barcoo</i>	Passed superior
P.M/6657	Coad, F. W. . .	E.R.A.A/4th	<i>Glenelg</i>	Passed satisfactory
P.M/6399	Irvine, L.	E.R.A.A/4th	<i>Parkes</i>	Passed satisfactory
P.M/4087	Ebsworth, A. N.	E.R.A.A/4th	<i>Moreton</i>	Passed satisfactory
P.M/3948	Eddy, L. V.	E.R.A.A/4th	<i>Moreton</i>	Passed satisfactory
B/3352	Cameron, P. . .	E.R.A.A/4th	<i>Moreton</i>	Passed superior
P.M/6648	Dobson, H. J. . .	E.R.A.A/4th	<i>Matthew Flinders</i>	Passed satisfactory
P.M/6878	Armstrong, E. R.	E.R.A.A/4th	<i>Ipswich</i>	Passed superior
P.M/6079	Vaughan, J. G. . .	E.R.A.A/4th	<i>Melville</i>	Passed satisfactory

EXAMINATION OF ENGINE ROOM RATINGS—continued.

O.N.	Name.	Present Rating.	Application Received From.	Result.
E.R.A.A/4th Class for Confirmation—continued.				
P.M/6649	Deverell, A. C. . .	E.R.A.A/4th	Gascoyne ..	Passed superior
H/2658	Newitt, T. E. W.	E.R.A.A/4th	Lithgow ..	Passed superior
F/4962	Williams, T. W.	E.R.A.A/4th	Dubbo ..	Passed superior
P.M/6799	Vernon, E. F. . .	E.R.A.A/4th	Wato ..	Passed satisfactory
S/7252	Chadwick, H. H.	E.R.A.A/4th	Cowra ..	Passed superior
P.M/6606	Davis, H. G. . .	E.R.A.A/4th	Cowra ..	Passed superior
F/4092	Stuart, W. K. . .	E.R.A.A/4th	Shepparton ..	Passed satisfactory
S/9019	Blight, A. C. . .	E.R.A.A/4th	Australia ..	Passed satisfactory
P.A/4260	Wilson, R. . .	E.R.A.A/4th	Australia ..	Passed satisfactory
P.M/7101	Linton, A. W. . .	E.R.A.A/4th	Australia ..	Passed satisfactory
P.M/6789	Muddyman, H. G.	E.R.A.A/4th	Latrobe ..	Passed satisfactory
S/8895	Sheldrick, R. A.	E.R.A.A/4th	Benalla ..	Passed satisfactory
P.M/6656	Bounds, R. M. . .	E.R.A.A/4th	Australia ..	Passed satisfactory
P.A/3924	Button, L. S. . .	E.R.A.A/4th	Hobart ..	Passed satisfactory
P.A/4382	Smerdon, K. G. . .	E.R.A.A/4th	Hobart ..	Passed superior
S/3230	Morton, F. J. . .	E.R.A.A/4th	Hobart ..	Passed superior
P.A/4447	Ramsay, G. . .	E.R.A.A/4th	Shepparton ..	Passed satisfactory
P.M/6546	Malcolm, A. . .	E.R.A.A/4th	Ballarat ..	Passed superior
P.M/7192	Pardy, L. C. . .	E.R.A.A/4th	Kalgoorlie ..	Passed satisfactory
S/9164	Wehleck, K. I. . .	E.R.A.A/4th	Fremantle ..	Passed satisfactory
P.A/3855	Smith, D. W. . .	E.R.A.A/4th	Hobart ..	Passed satisfactory
S/3160	Walker, N. R. . .	E.R.A.A/4th	Arunta ..	Passed superior
S/8850	Butler, R. E. . .	E.R.A.A/4th	Kybra ..	Passed superior
S/8915	Henry, H. H. S.	E.R.A.A/4th	Quiberon ..	Passed superior
P.M/6805	Maxwell, A. . .	E.R.A.A/4th	Quiberon ..	Passed satisfactory
P.A/4512	Jensen, R. A. . .	E.R.A.A/4th	Coolebar ..	Passed satisfactory
S/9163	Talty, M. F. . .	E.R.A.A/4th	Bundaberg ..	Passed satisfactory
S/9108	Hardy, F. . .	E.R.A.A/4th	Bundaberg ..	Passed satisfactory
P.M/1681	Pennell, E. J. . .	E.R.A.A/4th	Nepal ..	Passed satisfactory
P.M/6439	Coward, J. M. . .	E.R.A.A/4th	Shropshire ..	Passed satisfactory
S/8479	Gardner, W. . .	E.R.A.A/4th	Penguin ..	Passed satisfactory

Stoker Petty Officer for Chief Stoker.

22910	Stallard, H. W.	S.P.O.	Lismore ..	Passed satisfactory
P.M/2518	Saunders, R. W.	S.P.O.	Lismore ..	Passed satisfactory
W/770	Gardner, L. A.	S.P.O.	Adelaide ..	Passed superior
22640	Leonard, G. A.	S.P.O.	Torrens ..	Passed satisfactory
20488	Nunn, W. A. . .	S.P.O.	Australia ..	Passed satisfactory
22723	Evans, M. C. D.	S.P.O.	Australia ..	Passed satisfactory
22636	Mitchell, M. S. . .	S.P.O.	Hobart ..	Passed exceptional
23448	Wilson, B. . .	S.P.O.	Melville ..	Passed superior
20879	Rigg, H. J. . .	S.P.O.	Gascoyne ..	Passed satisfactory
21522	Jarman, W. A.	S.P.O.	Mildura ..	Passed satisfactory
21259	Pemberton, R. . .	S.P.O.	Latrobe ..	Passed superior
16291	Standeven, L. G.	S.P.O.	Moresby ..	Passed superior
19395	Coleman, G. L.	S.P.O.	Penguin ..	Passed exceptional
22625	Evans, E. C. . .	S.P.O.	Horsham ..	Passed satisfactory
23238	Clark, G. H. . .	S.P.O.	Bundaberg ..	Passed superior
11248	Johnston, A. L.	S.P.O.	Bundaberg ..	Passed superior
21168	Atkins, S. J. . .	S.P.O.	Bundaberg ..	Passed superior
20165	Meldrum, W. I.	S.P.O.	B/D. Darwin	Passed satisfactory
14736	Gregory, R. H.	S.P.O.	Rocklea ..	Passed satisfactory
20458	Dayman, R. . .	S.P.O.	Stuart ..	Passed satisfactory
21528	Cotton, B. S. . .	S.P.O.	Shropshire ..	Passed superior
23022	Temple, C. A. . .	S.P.O.	Benalla ..	Passed superior

2. The necessary notation should be made on the appropriate Forms A.S.1233_G or A.S.1246_A of these ratings.

3. Forms A.S.442 for successful and unsuccessful candidates have been forwarded to ships and establishments concerned for signature by the candidates. The original is to be retained by the candidate and the duplicate forwarded to the Commodore Superintendent of Training.

4. Candidates who failed to sit for the above examination for reasons beyond their control will not be penalized provided that a fresh application is made on Form A.S. 442 to sit for the next examination. A statement of the reasons for missing the last examination must accompany Form A.S.442. If satisfactory reasons are given, the passing date for successful candidates will be ante-dated to the date of the previous examination.

(465/207/1260.)

(This Order will be reprinted for posting on Notice Boards.)

300.

EDUCATIONAL TEST I, MARCH, 1945.

The following ratings passed Educational Test I, held 20th March, 1945:—

Name.	Rating.	O.N.	Result.
<i>H.M.A.S. Cerberus.</i>			
Adams, Henry D. . .	Stoker, 3rd Class ..	F/5414	Passed
Ainsworth, Kenneth J. . .	Stoker, 3rd Class ..	S/9649	Passed
Alexander, Darrel J. . .	Stoker, 3rd Class ..	H/2892	Passed
Archer, Ronald J. . .	Stoker, 2nd Class ..	H/2870	Passed
Aslin, Robert D. . .	Assistant Steward ..	P.A/4992	Passed
Blade, Kenneth G. . .	Stoker, 2nd Class ..	P.M/7456	Passed
Bowman, Kenneth F. . .	Stoker, 2nd Class ..	P.A/4672	Passed
Bulow, Eric S. . .	Stoker, 2nd Class ..	B/5279	Passed
Choyce, Ian E. . .	Stoker, 2nd Class ..	F/5425	Passed
Cox, Thomas H. . .	Stoker, 2nd Class ..	W/3063	Passed
Daley, Brendan L. . .	Assistant Stoker ..	W/2362	Passed
Davies, Harold . . .	Stoker, 3rd Class ..	B/5246	Passed
Dawes, Graham . . .	Assistant Steward ..	P.M/7953	Passed
Dawson, Lindsay V. . .	Stoker, 2nd Class ..	P.A/5003	Passed
Eades, John R. . .	Stoker, 2nd Class ..	W/3072	Passed
Ginn, Colin E. . .	Stoker ..	F/4584	Passed
Gordon Stewart T. . .	Stoker, 2nd Class ..	W/3069	Passed
Grubb, Wallace E. . .	Stoker ..	H/2036	Passed
Farrington, Alfred W. . .	Stoker, 2nd Class ..	F/5459	Passed
Hinton, Leonard J. . .	Assistant Stoker ..	S/7206	Passed
Holmes, Ronald J. . .	Assistant Steward ..	P.M/8012	Passed
Kenna, Maxwell G. . .	Stoker, 2nd Class ..	H/2871	Passed
King, Colin D. . .	Stoker, 3rd Class ..	H/2868	Passed
Lock, William J. . .	Stoker, 2nd Class ..	P.A/4968	Passed
Manners, John L. . .	Stoker, 2nd Class ..	F/5419	Passed
Miatke, Leo . . .	Stoker, 2nd Class ..	P.A/4969	Passed
McDade, James . . .	Stoker, 2nd Class ..	B/5247	Passed
Norris, Brian D. . .	Assistant Steward ..	B/5259	Passed
Oliver, Norman . . .	Stoker, 2nd Class ..	S/9781	Passed
Oliver, Ronald G. . .	Stoker, 2nd Class ..	P.A/4970	Passed
Palmer, John L. . .	Able Seaman ..	24078	Passed
Parslow, Maurice D. . .	Assistant Steward ..	P.A/5080	Passed

EDUCATIONAL TEST I, MARCH, 1945—continued.

Name.	Rating.	O.N.	Result.
<i>H.M.A.S. Cerberus</i> —continued.			
Preston, Richard G. ..	Stoker, 2nd Class ..	B/5248	Passed
Roughan, James J. J. ..	Assistant Steward ..	B/5318	Passed
Rowe, Henry R. ..	Stoker, 2nd Class ..	P.A/4973	Passed
Smart, Roy ..	Stoker, 3rd Class ..	B/5249	Passed
Shortell, Raymond L. ..	Leading Stoker ..	S/4755	Passed
Smith, John S. ..	Assistant Steward ..	F/5522	Passed
Snook, Lyell D. ..	Stoker, 2nd Class ..	P.A/4975	Passed
Spencer, Leonard A. ..	Stoker, 2nd Class ..	W/2962	Passed
Stone, Norman E. ..	Stoker, 2nd Class ..	S/9824	Passed
Sullivan, John R. ..	Assistant Steward ..	P.M/7798	Passed
Templeton, Desmond F. ..	Stoker, 2nd Class ..	W/3010	Passed
Valantine, Sidney G. ..	Stoker, 3rd Class ..	B/5283	Passed
Walker, James E. ..	Stoker ..	S/6652	Passed
Ward, John K. ..	Stoker, 2nd Class ..	B/5250	Passed
Wogandt, Mervyn C. ..	Stoker, 2nd Class ..	B/5180	Passed
Wolters, Frederick J. ..	Stoker, 2nd Class ..	B/5251	Passed
Wright, Neville J. ..	Assistant Steward ..	S/9926	Passed
<i>H.M.A.S. Hobart.</i>			
Drummond, Alan E. ..	Stoker ..	B/3825	Passed
<i>H.M.A.S. Melville.</i>			
McGinley, Reginald H. ..	Leading S.B.A. ..	23219	Passed
<i>H.M.A.S. Moresby.</i>			
Chester, Peter A. ..	Able Seaman ..	P.M/4834	Passed
Mennie, Lyon C. ..	Able Seaman ..	P.M/3019	Passed
2. The following qualified educationally for Acting Leading Stoker:—			
<i>H.M.A.S. Cerberus.</i>			
Bannear, Lance C. ..	Stoker, 2nd Class ..	P.A/4965	
Bernhardt, Barrington D. ..	Stoker, 2nd Class ..	S/9760	
Bryant, Allan L. ..	Stoker, 2nd Class ..	W/3067	
Burton, Frederick R. ..	Stoker, 2nd Class ..	S/9594	
Coates, Robert ..	Stoker, 2nd Class ..	F/5458	
Crinion, Vincent W. ..	Stoker, 2nd Class ..	S/9836	
Elliott, Robert B. ..	Stoker, 2nd Class ..	S/9878	
Hopkins, Raymond M. ..	Stoker, 2nd Class ..	F/5405	
Sandford, Alfred J. ..	Stoker, 2nd Class ..	W/3053	
Townsend, Ernest W. ..	Stoker, 2nd Class ..	S/9828	
Trewern, William A. ..	Stoker, 2nd Class ..	F/5527	
Walsh, John B. ..	Stoker, 2nd Class ..	S/9830	
Woodland, Gerald T. ..	Stoker, 2nd Class ..	F/5465	
<i>H.M.A.S. Leeuwin.</i>			
Dare, Norman V. ..	Leading Stoker ..	W/1953	
<i>H.M.A.S. Moresby.</i>			
Conaghan, Edmund ..	Stoker ..	B/3309	
Hill, George ..	Stoker ..	B/3829	
Morgan, Eric C. ..	Stoker ..	S/8965	
Scott, Mervyn J. ..	Stoker ..	B/3619	
Stephens, Richard J. ..	Stoker ..	W/2665	

(465/205/667.)

(This Order will be reprinted for posting on Notice Board.)

301.

ENGINE ROOM RATINGS—WATCHKEEPING CERTIFICATES.

When engine room ratings are due for the award of stokehold watchkeeping, engine room watchkeeping, or charge certificates in ships where no engineer officer is borne, arrangements are to be made for the appropriate examination to be conducted by an engineer officer of the rank of lieutenant or above, who is to sign the relevant certificate on form A.S.455.

2. Commanding officers are to ensure that covering forms A.S.161 in respect of the award of such certificates are rendered forthwith.

(453/202/1016.)

302.

W/T EQUIPMENT—REQUISITIONED VESSELS—MAINTENANCE OF, BY AMALGAMATED WIRELESS (AUSTRALASIA) LTD.

The W/T equipment fitted in requisitioned vessels comes under four categories—

- Property of the shipowner fitted and maintained under an agreement with A.W. (A.) Ltd.
- Property of A.W. (A.) Ltd., fitted and maintained under a rental maintenance agreement with the R.A.N.
- Property of the shipowner and maintained by the R.A.N.
- Property of, and maintained by, the R.A.N.

2. In the case of equipment in categories (a) and (b), application for maintenance, spares, and replacements should be made to the nearest agent of A.W. (A.) Ltd. Example of these types of equipment are—

Category (a) "Udisco"; T.C.3.

Category (b) K.12A; K.13A; K.14.

Category (c) Shipowners' equipment installed in *Doomba, Poyang, Pingwo, Yunman, Reserve, Sprightly, and Hawk.*

Category (d) Army "C" Mark II; 3B Teleradio, R.C.8 Transceiver; AT/AR8; F.S.6.

3. In addition, hire and/or maintenance agreements exist with A.W. (A.) Ltd., in respect of W/T equipment, other than equipment owned by the R.A.N., *vide* (d) above, installed in the following ships:—

<i>Bungaree</i>	<i>Koompartoo</i>	<i>Manunda</i>
<i>John Oxley</i>	<i>Kybra</i>	<i>Matthew Flinders</i>
<i>Kanimbla.</i>	<i>Manoora</i>	<i>Samuel Benbow</i>
<i>Wanganella</i>	<i>Westralia.</i>	

(612/246/3112.)

303.

FUNERAL EXPENSES—PAYMENT OF PRESS NOTICES.

With reference to paragraph 2 of Navy Order 553 of 1943 (as amended by Navy Order 230 of 1944), the cost of one Press notice in connection with the funeral of a deceased member may, in view of the existing conditions governing funerals of deceased members of the Forces during time of war, be accepted as a charge to public funds where the Department arranges the funeral.

(401/201/4531.)

304.

ESTABLISHMENT OF NAVAL STORES FOR H.D.M.Ls.

The under-mentioned small tools have been added to the List of Special Allowances for H.D.M.Ls.:

<i>Patt. No.</i>	<i>Description.</i>	<i>Qty.</i>
	Screw drivers	1 set
	Chisel, paring 1½ in.	1 No.
	Plane, hand	1 No.
	Snips, tin	1 pair.

(612/201/5604.)

305.

RESTRICTED ISSUES OF FRESH MILK AND MILK PRODUCTS.

In confirmation of message T.O.O. 010326 June, as amended by message T.O.O. 060727 June, 1945, the following sub-paragraph is to be inserted at the end of section B of Navy Order 265 of 1944:—

“(vii) *Milk.*

Subject to paragraphs 2 to 6 hereunder, inclusive, the issue of fresh milk and milk products to general messes and repayment messes is not to exceed the following:—

- (a) All sea-going ships, also shore-based personnel in operational areas north of Australia—one half pint of fresh milk or 4 oz. of unsweetened condensed milk or 1½ oz. of full cream dried milk per head daily.
- (b) All harbor ships and personnel at mainland bases—one half pint of fresh milk or 3 oz. of unsweetened condensed milk or 1 oz. of full cream dried milk per head daily.”

2. The daily ration for female personnel is to be one pint of fresh milk, when available, or 5 oz. of unsweetened condensed milk or 1½ oz. of full cream dried milk.

3. Fresh milk for sick mess personnel may normally be issued on a basis of one pint per head daily, but in individual cases the ration may be increased up to a maximum of two pints per head, and more in special cases, at the discretion of the naval medical officer concerned.

4. Issues for cadet midshipmen at the Naval College may be made up to a maximum of 1½ pints per head daily.

5. The foregoing allowances are to include the daily requirements of milk for cooking and for all other purposes, excepting approved extra issues referred to in C.O.R., Article 423.

6. The use of tinned milk or dried milk is permitted under (b) above only to the extent necessary to provide the equivalent of the deficiency of fresh milk on occasions when the full authorized ration of fresh milk is not available.

7. Summarized weekly issues of fresh milk and milk products are to be included in the weekly statement of rationed items referred to in B, sub-section (i) (f) of Navy Order 265 of 1944.

(350/201/85.)

306.

NAVAL PERSONNEL PROCEEDING ON LEAVE OR DISCHARGED—SUPPLY OF CIGARETTES AND TOBACCO.

With reference to Navy Order 82 of 1945, it is notified for general information that, as from 1st July, 1945, the maximum quantities of tobacco and cigarettes to be supplied to personnel proceeding on long leave and to personnel discharged to civil life are as follows:—

Personnel proceeding on long leave.

(a) *In Darwin area.*

3 oz. of tobacco or 105 No. cigarettes per head per week.

(b) *In all other areas in Australia.*

Males—2½ oz. of tobacco or 85 cigarettes per head per week.

Females—70 cigarettes per head per week.

Personnel discharged to civil life.

Personnel may draw, on discharge, up to 24 days' supply of cigarettes or tobacco on the basis shown in paragraph 1 (b) above.

(612/244/114.)

307.

H.M.A. M.Ls., H.D.M.Ls. AND A.S.R. BOATS—FORMS A.D.495 (REPORT OF DOCKING) AND FORM A.D.488 (PROPELLERS AND UNDERWATER FITTINGS)—PROCEDURE.

On each occasion of docking of H.M.A. M.Ls. at all docks (or slips), the naval refitting authority is to prepare the above forms in quadruplicate for distribution as follows:—

Original—To the administrative authority of the craft, for transmission to the Naval Board.

Duplicate—To the administrative authority of the craft.

Triplicate—To be retained by the refitting authority concerned.

Quadruplicate—To boat for retention in ship's book.

2. This procedure applies when docking (or slipping) at all docks (or slips) and the distinction indicated on the forms is in abeyance during hostilities.

3. In order to assist the dockyard and base repair staff officers in estimating the time for docking or slipping, commanding officers are to ensure that docking defect lists contain information concerning (a) rudder, (b) “A” bracket and (c) stern tube clearances on last occasion of docking.

(603/246/5180.)

308.

**ADVICE OF NAVAL STORES PURCHASED—MARKING OF LEDGER
WHEN STORE CHARGE CERTIFICATE IS GIVEN.**

The attention of all concerned is drawn to the necessity for compliance with the provisions of Article 25 (8) of the R.A.N. Supplement to the Naval Storekeeping Manual B.R.4 and Navy Order 609 of 1943, regarding check of ledger entries when signing the store charge certificate on claims for payment, and particularly to the marking of ledgers on passing such claims.

2. It has been observed that deliveries of naval stores on different dates and purchased in respect of more than one order have been included on the one letter of advice form A.S.133. In future, each delivery of naval stores against each order placed is to be taken on charge in the naval store account by a separate form A.S.133 or A.S.133z, as applicable.

(401/201/4123.)

309.

**FORM A.S.542—ROUTE ORDER AND TRAVELLING EXPENSE
CLAIM.**

With reference to Navy Orders 135 and 433 of 1943, it has been brought under notice that many instances occur in which members, when proceeding on transfer from one ship or depot to another, are not provided with form A.S.542 as prescribed, resulting in inconvenience and delay in the preparation and settlement of travelling expense claims.

2. Commanding officers should take steps to ensure that the instructions laid down in regard to the issue of this form are complied with in all cases.

(407/221/2764.)

By Authority: H. E. DAW, Government Printer, Melbourne.

RESTRICTED.(FOR OFFICIAL USE ONLY.)

Commonwealth Navy Orders.

Navy Office, Melbourne,

24th July, 1945.

The following Orders, having been approved, are hereby promulgated for information and guidance, and necessary action.

By direction of the Naval Board,

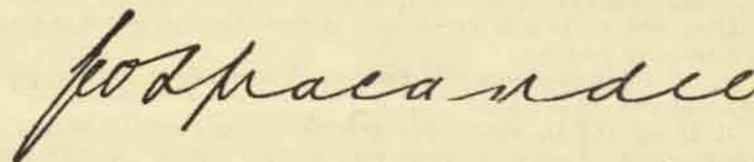

Secretary.

*The Commodore Commanding H.M.A. Squadron,
and Commanding Officers of H.M.A. Ships,
Officers in Charge of H.M.A. Naval
Establishments, and others concerned.*

TABLE OF CONTENTS.

No.	Subject.
310.	Repatriated Prisoners of War—Medical Histories.
311.	Ordnance Q.F. 40 mm. Bofors—Liquid in Recoil Buffer.
312.	40 mm. Bofors Mk. IIIA Mountings—Position of Ready Use Racks Patt. No. 7100.
313.	Cartridges B.L. 8-in. Cordite S.C. 205 Lot M.E.C. 200—Low Muzzle Velocity.
314.	Cartridges Signal 1-in. Green Mk. XI T—Lots 1 to 9, M.E. 10/42 Inclusive—Restriction.
315.	Replenishment of Naval Stores—H.M.A. Ships.
316.	Officers' Working Dress.
317.	Condemnations of Provisions in Ships and Naval Establishments.
318.	Compensation for Watches Lost by Naval Personnel as a Result of a Service Casualty—Officers and Ratings.
319.	Form A.M. 47Z—Medical History Document Record Card, C.7108/45.

310.

REPATRIATED PRISONERS OF WAR—MEDICAL HISTORIES.

All repatriated prisoners of war are to be medically examined upon their first reception into an R.A.N. establishment. This examination should be directed towards ascertaining whether any medical treatment is required during the first period of leave, whether any disease exists which might constitute a danger to other persons, or whether any condition or disease exists which should be reported to the Commonwealth Department of Health in accordance with Navy Order 330 of 1941. Further interrogations for the purpose of recreating medical history sheets are to be deferred until the commencement of the rehabilitation course.

2. Medical history documents are to be recreated for all repatriated prisoners of war during their rehabilitation course and these are to be completed as fully as possible with details supplied by the repatriated men, who are to be warned of the possible implications for their future treatment of neglect to advise any illness or disability suffered by them in prisoner of war camps.

(567/201/8.)

311.

ORDNANCE Q.F. 40 mm. BOFORS—LIQUID IN RECOIL BUFFER.

Recoil buffers of ordnance Q.F. 40 mm. Bofors of all types are to be filled with oil D.T.D. 44D instead of glycerine and water to conform to Admiralty practice.

2. All ships mounting this gun are to demand, as first supply, one gallon of this oil per gun.

3. If oil D.T.D. 44D is not available, a mixture of 60 per cent. glycerine and 40 per cent. water may be used instead (in cold weather use 80/20 mixture). Buffers filled with glycerine and water should be drained and refilled with D.T.D. 44D as soon as adequate supplies are available. Glycerine and water and D.T.D. 44D must not be mixed. Buffers are to be thoroughly drained before refilling with a different type of liquid.

4. When buffers are filled with glycerine and water, the letter "G" 1 inch high is to be painted on the buffer near the filling plug, in white paint. The "G" is to be painted out when the liquid is changed to D.T.D. 44D.

5. A reference to this Navy Order is to be inserted in all copies of A.B.R. 171 against paragraph 57.

6. Navy Order 375 of 1944 is cancelled.

(490/212/1328.)

312.

40 mm. BOFORS MK. IIIA MOUNTINGS—POSITION OF READY USE RACKS PATT. No. 7100.

To provide sufficient space on the left platform of Single Bofors Mountings Mk. IIIA for the sight operator when sights correctional are fitted in accordance with Navy Orders 57 and 130 of 1945, the left hand ready use rack Patt. 7100 is to be repositioned on all mountings concerned.

2. The position shown in appended D.O.T.M. Diagram No. 86860 is recommended where space around the mounting permits.

3. The work should be carried out by ships' and ordnance base staffs where possible. If dockyard assistance is required, the work should be treated as a defect.

(603/246/4557.)

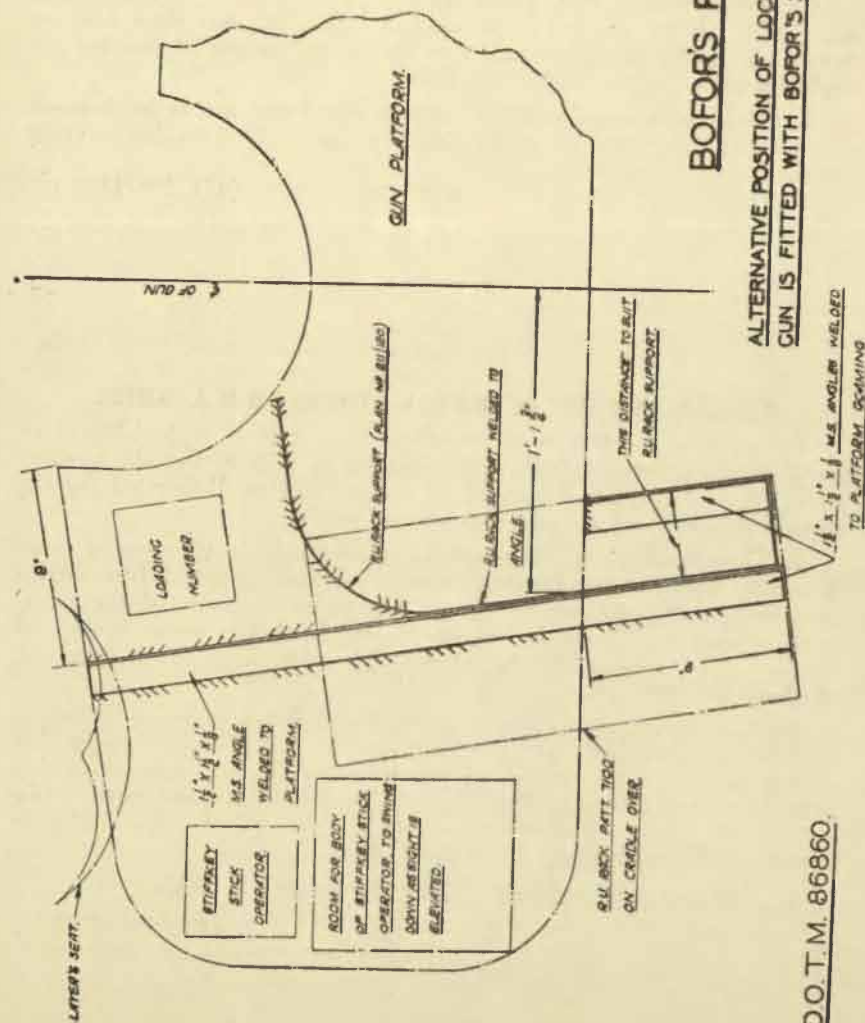
**BOFOR'S R.U. LOCKERS.**

ALTERNATIVE POSITION OF LOCKER PATT. 7100 ON LAYER'S SIDE, WHEN GUN IS FITTED WITH BOFOR'S SIGHTS 'CORRECTIONAL' ("STIFFKEY STICK")

D.O.T.M. 86860

313.

CARTRIDGES B.L. 8-in. CORDITE S.C. 205 LOT M.E.C. 200—LOW MUZZLE VELOCITY.

Check-proof of cordite S.C. 205, Lot M.E.C. 200 in the parent gun indicates that 8-in. charges made up with this lot of cordite may be expected to give an M.V. 13 f.s. below normal with full charges and 10 f.s. below normal with reduced charges, and allowance should be made accordingly.

(471/204/881.)

314.

CARTRIDGES SIGNAL 1-in. GREEN MK. XI T.—LOTS 1 TO 9, M.E. 10/42 INCLUSIVE—RESTRICTION.

Cartridges Signal 1-in. green Mk. XI T. of Lots 1 to 9 inclusive, filled M.E. 10/42, are not to be fired and all such cartridges held on board are to be dumped and serviceable cartridges demanded in replacement.

2. Stocks at Naval Armament Depots and Bases are to be disposed of forthwith, the stores being included in a report of survey for covering approval.

(471/208/1312.)

315.

REPLENISHMENT OF NAVAL STORES—H.M.A. SHIPS.

It has been noted that, on occasions of periodical replenishment of naval stores, a tendency exists, particularly in A.M.S. Vessels, to over-stock, quantities being demanded in excess of those authorized for the storing period based on past expenditure.

2. This position was to an extent unavoidable in the case of ships in remote areas as requirements were, as a rule, supplied from mainland depots. Conditions have now altered as a result of the naval store issuing ship being in operation, which enables escort vessels in northern New Guinea waters to replenish with naval stores regularly at short notice.

3. It is necessary to conserve available stocks of naval stores to meet all requirements, and demands on the naval store issuing ship should in future be limited to requirements for the normal storing period, having due regard to foreseen abnormal expenditures. Discretion should be exercised in replenishing stocks of stores liable to deterioration, particularly in tropical climates.

4. Attention is also drawn to Navy Order 287 of 1945.

(612/201/2795.)

316.

OFFICERS' WORKING DRESS.

With reference to the Uniform Regulations for Officers of the Fleet, as contained in the Appendix to Admiralty Navy List, the Naval Board have approved that blue working dress (No. 5A) may be worn as an optional dress by R.A.N., R.A.N.R., and R.A.N.V.R. officers in shore establishments, or otherwise employed ashore in Australia, when blue dress is the rig of the day.

2. The wearing of this working dress by officers is to be confined to working hours and whilst proceeding between their residences and their places of duty.

3. The necessary arrangements for the supply of this dress are being made with the naval outfitters operating in the several States under the current agreement for the supply of officers' uniforms, also with the Commonwealth Government Clothing Factory, and details and prices will be promulgated in Navy Orders at an early date.

(434/215/1126.)

317.

CONDEMNATIONS OF PROVISIONS IN SHIPS AND NAVAL ESTABLISHMENTS.

With reference to Confidential Commonwealth Navy Order 16 of 1944 and Navy Order 36 of 1945, the attention of all officers concerned is again drawn to the necessity for exercising strict supervision over stocks of fresh and dry provisions maintained and for rigid compliance with regulations, instructions and Orders relating thereto.

2. It is apparent from an examination of Forms A.S. 330 and provision accounts (Forms A.S. 83 (1) and A.S. 462z) that the various instructions issued for the purpose of reducing losses to a minimum are in many cases not being fully observed, and abnormal condemnations are still occurring, especially in small ships, which would have been avoided, or much reduced, if adequate supervision and care had been exercised in the required control of stocks carried. More serious notice will be taken in future, therefore, to such omissions which cause or contribute to losses.

3. In order to guard satisfactorily against avoidable waste of fresh provisions, it is essential that accountant officers, also commanding officers of ships in which an accountant officer is not borne, should take every precaution to ensure that demands for requirements are on all occasions rigidly restricted in the case of each item to the period for which the total quantity will remain wholesome under the prevailing storage conditions. In this connection, attention is specially drawn to the general instructions contained in C.O.R., Article 421 (1942 Edition), non-observance of which in future will necessitate the imposition of penalties under Naval Financial Regulations and Instructions, Article 9, in the event of condemnations resulting from excessive quantities carried.

4. In regard to the treatment, preservation, storage, &c., of provisions generally, special attention is also drawn to Part II of Volume I of the Manual of Victualling, and particularly to Chapter V thereof relating to cold storage. The precautions prescribed therein to guard against losses, and the care to be exercised in order to ensure effective preservation of provisions of all descriptions normally carried in H.M.A. Ships, must be closely observed on all occasions if the application of Naval Financial Regulations and Instructions, Article 9, is to be avoided.

5. Hitherto the greatest percentage of losses on board—especially in sea-going tenders—has been in the various descriptions of refrigerated meat, and these losses have been mainly due to excessive quantities carried. It is therefore directed that in future, the maximum meat stocks maintained in tenders in refrigerated storage are to be limited to requirements, calculated on the approved weekly ration, for thirty (30) days, except when for operational or other special reasons a greater quantity is specifically authorized by higher authority.

6. Parent ships are to take immediate steps to ensure that Volume I of the Manual of Victualling is supplied to any sea-going tender which does not possess a copy of that publication for guidance and ready reference.

(612/243/2016.)

318.

COMPENSATION FOR WATCHES LOST BY NAVAL PERSONNEL AS A RESULT OF A SERVICE CASUALTY—OFFICER AND RATINGS.

With reference to Admiralty Fleet Order 6813/44, Section III, paragraph 1 (b), it has been decided to adopt in the R.A.N. forthwith a revised procedure for dealing with claims in respect of watches lost by naval personnel as a result of a Service casualty, and the maximum sum of £1 authorized therein for payment to ratings in respect of such loss is no longer operative.

2. In future, claims by officers and ratings for watches lost as a result of a Service casualty will be dealt with by the Naval Board and particulars of any watches included in claims by ratings for loss of kit dealt with by commanding officers in accordance with the instructions contained in Navy Order 561 of 1944 are to be extracted and forwarded to Navy Office for consideration of the Naval Board.

3. Claims in respect of watches lost are to include:—

- (a) a description of the watch;
- (b) cost when new;
- (c) date and place of purchase; and
- (d) evidence as to ownership, e.g., production of a receipt in respect of purchase or a statement by some independent person that the claimant was known to be in possession of such a watch.

(438/204/208.)

319.

FORM A.M. 47z—MEDICAL HISTORY DOCUMENT RECORD CARD.

The above-mentioned form has been introduced for use in the new system for controlling Medical History Documents, particulars of which have been promulgated to the principal shore establishments of the R.A.N.

2. These forms will be issued by the Medical and Dental Store Officer, R.A.N. Medical Store, Glebe, New South Wales, to the following establishments, without demand:—

H.M.A.S. <i>Penguin</i>	6,000
H.M.A.S. <i>Rushcutter</i>	3,000
H.M.A.S. <i>Kuttabul</i>	1,500
H.M.A.S. <i>Cerberus</i>	2,000
H.M.A.S. <i>Lonsdale</i>	2,000
H.M.A.S. <i>Moreton</i>	3,000
H.M.A.S. <i>Melville</i>	4,000
H.M.A.S. <i>Leeuwin</i>	3,000
H.M.A.S. <i>Madang</i>	5,000
H.M.A.S. <i>Torrens</i>	1,000
H.M.A.S. <i>Huon</i>	1,000

3. If greater numbers than the above are required, they may be demanded from the Medical and Dental Store Officer.

(480/201/3546.)

RESTRICTED.(FOR OFFICIAL USE ONLY.)

Commonwealth Navy Orders.

Navy Office, Melbourne,
31st July, 1945.

The following Orders, having been approved, are hereby promulgated for information and guidance, and necessary action.

By direction of the Naval Board,

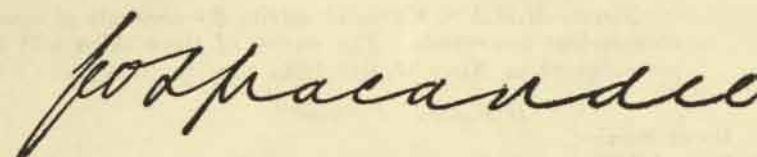

Secretary.

*The Rear-Admiral Commanding H.M.A. Squadron,
and Commanding Officers of H.M.A. Ships,
Officers in Charge of H.M.A. Naval
Establishments, and others concerned.*

TABLE OF CONTENTS.

No.	Subject.
320.	Sydney Command.
321.	Correspondence and Signals for Flag Officer-in-Charge and Admiral Superintendent, Sydney.
322.	Gowrie Scholarship Trust Fund.
323.	W.R.A.N.S.—Marks of Respect.
324.	Communication Branch Ratings—Non Substantive Rates.
325.	Civilian Identity Cards and Certificates of Service.
326.	Concession Messages to Naval Personnel.
327.	Telephone Trunk Line Calls by Naval Personnel.
328.	Naval Armament Stores Returned by H.M.A. Ships—Vouchering.
329.	Radar Type A272/A276—Local Oscillator Unit—Modification.
330.	Income Tax.
331.	Travelling Warrants on Discharge or Demobilization.
332.	Replacement of Wooden Furniture by Tubular Steel Furniture—Reports.
333.	Grant for Tropical Outfit.

320.

SYDNEY COMMAND.

The list hereunder shows the attachment of R.A.N. personnel to the three depots in the Sydney Command.

H.M.A.S. "Kuttabul".

Defensively Equipped Merchant Ships—Equipment Staff.
 Degaussing Range Staff.
 Dockyard Staff (Naval).
 Flag Officer-in-Charge, Naval Secretariat, Naval Staff and Staff of Naval Base Headquarters.
 Independent Commands.
 Naval Control Service, Sydney.
 Port Dental Officer.
 Railway Transport Office.
 Sea Transport Office.
 Ship's Complement.
 Staff Officer (Reserves and recruiting).
 V.S.I.S. *Merkur*.

(NOTE.—H.M.A.S. *Kuttabul* carries the accounts of many independent commands. The names of these ships will be promulgated in Navy Orders from time to time.)

H.M.A.S. "Penguin".

Boom Service.
 Extended Defences.
 H.M.A.S. *Adelaide*.
 Hydrographic Branch.
 Port Kembla (in process of reduction).
 Ship's Complement.
 Signal Stations.
 Signal Training Centre (under construction).
 Target and Diving Parties.
 Tenders to H.M.A.S. *Penguin*.

Naval Establishment, Newcastle (H.M.A.S. "Maitland").
 (Accounts carried out in H.M.A.S. *Penguin*.)

H.M.A.S. "Rushcutter".

A/S School.
 Canonbury Naval Hospital and Naval Wing, Prince of Wales Hospital.
 Coastal Craft Section.
 Defensively Equipped Merchant Ships—Personnel.
 Randwick (Medical Officers, Staff and Patients).
 Ship's Complement.
 Tenders to H.M.A.S. *Rushcutter*.

Radar Training Establishment (South Head) (H.M.A.S. "Watson").
 (Accounts carried out in H.M.A.S. *Rushcutter*.)

Gunnery Instructional Centre (Woolloomooloo) (H.M.A.S. "Mindari").
 (Accounts carried out in H.M.A.S. *Rushcutter*.)

2. Navy Order 11 of 1943 is hereby cancelled.

(404/201/573.)

321.

CORRESPONDENCE AND SIGNALS FOR FLAG OFFICER-IN-CHARGE AND ADMIRAL SUPERINTENDENT, SYDNEY.

In order to facilitate quicker distribution and action, approval has been given, as a wartime measure, for correspondence and signals for the Flag Officer-in-Charge, and Admiral Superintendent, Sydney, to be addressed as follows:—

(A) *Royal Australian Navy Dockyard Matters*, including supply of stores and like matters by Royal Australian Navy Store Officer, where direct address to the Store Officer concerned is not sufficient. Admiral Superintendent, Sydney (Short Title A.S. Sydney).
 Office: Garden Island, Sydney.

(B) *Other Command Matters* .. Flag Officer-in-Charge, New South Wales (short title F.O.I.C.S.).
 Office: Naval Base Headquarters, Wylde-street, Potts Point, Sydney.

2. The Flag Officer-in-Charge, who is also the Admiral Superintendent, Sydney, maintains two offices, one at Naval Base Headquarters, Potts Point, as Flag Officer-in-Charge, and one at Garden Island as Admiral Superintendent. The routine administration of the Royal Australian Navy Dockyard is carried out at Garden Island for the Admiral Superintendent by the Deputy Superintendent (Captain of the Dockyard).

3. The Flag Officer-in-Charge, should be shown as an additional addressee of any matter referred to at (A) above which has also a staff aspect or requires action by other than yard authorities, e.g., alterations in berthing, working parties, transport, &c.

(549/201/95.)

322.

GOWRIE SCHOLARSHIP TRUST FUND.

The Trustees of The Gowrie Scholarship Trust Fund, Sir John Latham, Sir Robert Garran, Sir Claude Reading and Chief Judge H. B. Piper, announce the following awards for 1945:—

Post-Graduate Research Travelling Scholarships.
 ("Major Patrick Hore-Ruthven Memorial").

Wing-Commander Clive Selwyn Davis, D.F.C., R.A.A.F., M.Sc. (Sydney).

(Present Address—R.A.A.F., Laverton, Vic.)

Lieutenant (Sp.) Lawrence Nicholas Barrett Thomas, R.A.N.V.R., B.A., Dip.Ed. (Melbourne).

(Present Address—Department of the Navy, Melbourne.)

These scholarships are tenable for two years at universities abroad. Travelling expenses, fees at the University and other incidental expenses are paid under the scholarships up to a total value of £475 per annum Australian currency.

University Scholarships of £A.100 per annum, tenable for the normal period of the course to be taken.

"Gowrie Scholarship (Flying Officer Henry Lawrence Osborne Memorial)".

David Roderick Curtis, 42 Malane-street, Ormond, Victoria. Melbourne Boys' High School (Medicine, University of Melbourne).

"Gowrie Scholarship (Flight-Lieutenant W. E. Newton, V.C., Memorial)".

Murray Charles Groves, 765 Burwood-road, Hawthorn, Victoria. Melbourne Boys' High School (Arts and Law, University of Melbourne).

"Gowrie Scholarship (The Fairfax Foundation)".

Miss Ruth T. Maegraith (Residential address, care of Women's College, University of Sydney). Griffith High School, New South Wales (Medicine, University of Sydney).

"Gowrie Scholarship (Corporal J. H. Edmondson, V.C., Masonic Memorial)".

Miss Valerie T. Winslow, 29 Wolger-road, Mosman, New South Wales. North Sydney High School (Arts, University of Sydney).

Secondary School Scholarships of £A.50 per annum, tenable for two years at Secondary Schools.

"Gowrie Scholarship (Country Women's Association New South Wales Foundation)".

Harold L. Appleton, Hurlstone Agricultural High School, New South Wales.

"Gowrie Scholarship (Major Patrick Hore-Ruthven Memorial)".

Colin B. Cormie, 326 Given-terrace, Paddington, Brisbane. Toowoomba Grammar School.

"Gowrie Scholarship (H.M.A.S. *Leeuwin*, Western Australia Foundation)".

Miss Elizabeth B. Dixon, 26 Arthur-street, Subiaco, Western Australia. Perth Modern School.

"Gowrie Scholarship (Major Patrick Hore-Ruthven Memorial)".

Roger Hopkins, 601 St. Kilda-road, Melbourne, Victoria. St. Patrick's College, Sale.

"Gowrie Scholarship (H.M.A.S. *Cerberus* Victoria Foundation)".

Richard J. Ivers, 25 Maysia-street, Canterbury, Melbourne. St. Patrick's College, Sale.

"Gowrie Scholarship (Rob and Jack Cuming Memorial)".

Roderick G. Matheson, 212 Stanley-street, North Adelaide, South Australia. St. Peter's School Collegiate.

"Gowrie Scholarship (Captain Ian Frederick McMaster, M.C., Memorial)".

Kenneth A. Millar, 190 Beach-street, Coogee. Sydney High School.

"Gowrie Scholarship (Schools' Patriotic Fund South Australia Foundation)".

Gerald A. Phillips, 19 Rutland-avenue, Unley Park, South Australia. Unley High School.

"Gowrie Scholarship (Pilot-Officer William Wallace Anderson Memorial)".

Geoffrey R. Watson, 31 Blaxland-road, Bellevue Hill. Toowoomba Grammar School, Toowoomba.

"Gowrie Scholarship (Major Patrick Hore-Ruthven Memorial)".

Lloyd S. Zampatti, 127 Blencome-street, West Leederville, Western Australia. Perth Modern School.

1946 AWARDS.

2. Applications for Post-Graduate Research Travelling Scholarships should reach the Registrar of an Australian University not later than 31st December, 1945.

3. Applications for Secondary School Scholarships and University or similar scholarships should reach the Trustees, The Gowrie Scholarship Trust Fund, G.P.O. Box 2069, Sydney, not later than 31st December, 1945.

4. Scholarships are available only to members of the Forces who have served on active service during the existing war, or their descendants.

5. Forms of application are obtainable from the Trustees, and requests therefor should state the type of scholarship desired—i.e., Research Travelling Scholarship, University or similar Scholarship, or Secondary School Scholarship.

(474/203/558.)

(This Order will be reprinted for posting on Notice Boards.)

323.

W.R.A.N.S.—MARKS OF RESPECT.

W.R.A.N.S. officers are to be addressed by junior W.R.A.N.S. officers and ratings as "Madam."

2. Within the W.R.A.N.S., salutes are to be given as in the Royal Navy (K.R. and A.I. Articles 151-154) except that hats will not be removed. During the playing of the National Anthem indoors, members of the W.R.A.N.S. will stand to attention without saluting.

3. Naval salutes as a matter of discipline are to be exchanged ashore as follows:—

(a) All officers of the W.R.N.S., W.R.A.N.S., A.W.A.S., A.A.M.W.S., and W.A.A.A.F., Naval officers of the rank of Commander and above, officers of the Royal Marines, Army and Air Force of comparative rank, and Commanding Officers of their own establishments at all times are to be saluted by junior W.R.A.N.S. officers and ratings in uniform. Other Naval officers senior to them are to be saluted only if addressing or being addressed by them.

(b) On other occasions the exchange of the Naval salute will be governed by the ordinary rules of courtesy.

4. Paragraph 5 of Navy Order 30 of 1943 is hereby cancelled.

(432/224/3945.)

324.

COMMUNICATION BRANCH RATINGS—NON SUBSTANTIVE RATES.

As it is essential to have all higher communication ratings qualified to the same professional standard in order that they may be available for general service, it has been decided that all higher R.A.N.R. communication ratings are to qualify for the compulsory active service non-substantive rating corresponding to their substantive rate, such qualification to be carried out before the 31st December, 1945, e.g., yeomen of signals and petty officer telegraphists must pass a No. 2 lower standard examination.

2. Active service chief yeomen and chief petty officer telegraphists are required to pass the No. 2 higher standard examination, but in view of the period R.A.N.R. chief yeomen and chief petty officer telegraphists mobilized as such have already served in their rating, they will only be required to pass the No. 2 lower standard examination.

3. As it is realized that certain R.A.N.R. ratings may find difficulty in passing the required examination, a special course of three weeks will be arranged in H.M.A. Signal School. On receipt of this Order, names of ratings desiring to qualify are to be reported to the Naval Officer-in-Charge, Flinders Naval Depot, who will then arrange for such ratings to be drafted into Flinders Naval Depot for a course.

4. Ratings who, due to their age and lack of experience in modern signalling, feel that they would be unable to attain the desired standard may apply, through their commanding officers, for a "free" discharge, copy of applications to the Naval Board to be forwarded to the Naval Officer-in-Charge, Flinders Naval Depot.

5. The names of ratings who fail to pass the examination after undergoing a course are to be forwarded to the Naval Board with recommendations regarding their retention in the Service in lower substantive ratings.

(428/212/11.)

(This Order will be reprinted for posting on Notice Boards.)

325.

CIVILIAN IDENTITY CARDS AND CERTIFICATES OF SERVICE.

The following instructions regarding civilian identity cards are to be observed when personnel (male and female) enter the Naval Service or are demobilized or discharged.

On Entry.

2. (a) On mobilization, the civilian identity card is to be surrendered.
- (b) Each identity card surrendered is to be cancelled by the collecting authority and returned to the Commonwealth Electoral Officer in the capital city of the State where mobilization takes place.

- (c) If on mobilization the identity card is not surrendered, particulars of the name and civilian address of the person concerned, together with reasons for not surrendering the card, should immediately be forwarded to the Commonwealth Electoral Officer referred to in sub-paragraph (b) above.

3. It is essential that the above instructions be strictly observed, but it is important that no person be required to surrender an identity card until actual mobilization for service.

On Demobilization or Discharge—Issue of Certificate of Service and Application for Civilian Identity Card.

4. Any person who is discharged from the Naval Service is to be informed of the obligation to register and obtain an identity card. Such registration should be made immediately on discharge on Form C.R.I.

5. *Officers discharged or demobilized.*—A certificate in the following terms will in future be issued to all *officers* upon discharge or demobilization from the Royal Australian Navy and Reserves (including Women's Services).

Certificate of Discharge of an Officer.

This is to certify that (a).....
 who entered for full-time War Service in Royal Australian Navy
 on.....day of..... 19...., has
 served as a (b)..... Officer of the
 (c)..... from the..... day of
19...., to the..... day of.....
 19...., on which latter date (d) was demobilized
 with the approval of the Naval Board. This Officer's service in-
 cluded (e)

Secretary, Naval Board.

Signature of Officer.....

Notes.

- (a) Insert rank, name in full, and decorations.
- (b) Insert "Commissioned" or "Warrant."
- (c) Insert in full—
 R.A.N.
 R.A.N.R. (S).
 R.A.N.R.
 R.A.N.V.R.
 R.A.N.N.S.
 W.R.A.N.S.
- (d) Insert—"he" or "she."
- (e) Insert—"Active Service in Australia" and/or "Active Service outside Australia," and/or "Active Service at sea."

6. (a) *Ratings discharged*.—When the Certificate of Service cannot be handed to the rating, a certificate signed by the commanding officer of the ship in which discharge takes place is to be issued indicating the reason for discharge.
- (b) *Ratings demobilized*.—The commanding officer of the ship from which demobilization takes place is to issue a certificate to that effect.

7. When a rating who has been demobilized is remobilized, the civilian identity card is to be collected, cancelled and returned to the Commonwealth Electoral Officer concerned.

8. Navy Orders 409 and 420 of 1942 and 302 of 1944 are cancelled.

(404/201/728.)

326.

CONCESSION MESSAGES TO NAVAL PERSONNEL.

Private telegrams of an *urgent* nature (CONAVS) may be sent by next of kin to personnel serving in H.M. and H.M.A. Ships and in Naval Establishments overseas under the following conditions:—

- (a) Telegrams to be lodged at any telegraph office.
- (b) The address of such messages to contain the following information:—
 Rank or rating.
 Name of addressee.
 Name of ship.
 "Conav."
- (c) The charge to be paid by the sender to be 2d. per word, with a minimum of 1s. 0d. as for six words, the words contained in the address not being charged for.
- (d) The message not to exceed twelve (12) paid words.
- (e) The limit allowable to any one applicant to be a normal maximum of two (2) per month.
- (f) The text to relate solely to urgent private affairs, and not to contain congratulations, greetings, nor terms of endearment, and to be expressed in plain English language. This condition is essential as the messages are despatched through service channels of communication, and such traffic must be reduced to a minimum.
- (g) The signature for transmission to include a surname.

2. (a) This arrangement does not apply to messages to personnel serving in the following shore establishments to whom ordinary telegrams may be sent:—

H.M.A.S. *Cerberus* (Flinders Naval Depot), Victoria.
 H.M.A.S. *Penguin*, Sydney.
 H.M.A.S. *Moreton*, Brisbane.
 H.M.A.S. *Rushcutter*, Sydney.

H.M.A.S. *Lonsdale*, Melbourne.
 H.M.A.S. *Huon*, Hobart.
 H.M.A.S. *Leeuwin*, Fremantle.
 H.M.A.S. *Torrens*, Adelaide.
 H.M.A.S. *Melville*, Darwin.
 H.M.A.S. *Maitland*, Newcastle.
 H.M.A.S. *Watson*, Sydney.
 H.M.A.S. *Carpentaria*, Thursday Island.
 H.M.A.S. *Harman*, Canberra.
 H.M.A.S. *Kuttabul*, Sydney.
 H.M.A.S. *Magnetic*, Townsville.
 H.M.A.S. *Mindari*, Sydney.

(b) Ordinary telegrams will also be accepted for despatch to personnel serving in the following shore establishments, but they will be forwarded from the mainland by airmail:—

H.M.A.S. *Lusair*, Torokina.
 H.M.A.S. *Madang*, Madang.
 H.M.A.S. *Basilisk*, Port Moresby.
 H.M.A.S. *Ladava*, Milne Bay.

Messages of an urgent nature, however, viz.: births, deaths or matters demanding an urgent reply, will be treated as "Conavs" by the Postal Authorities and forwarded to Navy Office for transmission by W/T. The charge for such messages will be as in paragraph 1 (c) above.

3. It is desirable that personnel should advise their next of kin of the foregoing arrangements.

From Naval Personnel.

4. Each officer and man may send one private telegram per month over naval W/T channels to addresses in Australia only, subject to the following conditions:—

- (a) Text of messages to conform to the conditions set out in sub-paragraph 1 (f), and not to exceed twelve (12) words.
- (b) The name of ship, squadron or unit, rating or rank of sender not to be mentioned.
- (c) Address to be as short as possible.
- (d) Charge for text and address to be one penny a word, and if address exceeds five words no charge for extra words.
- (e) Telegrams to be written on service message forms. They will be censored before transmission.

5. A record is to be maintained in the ship showing name of sender and payment made.

6. The service is dependent on availability and capacity of service W/T channels and incidence of Service Traffic, which must always take precedence over private telegrams. Delivery cannot be guaranteed.

7. Navy Office, Melbourne, will pass messages to addressees.

8. The accountant officer is to take on charge in his cash account, moneys collected, and attach duplicates of messages in support of the entries in his cash accounts.

9. A.F.O. 1370 of 1941 is applicable to R.N. ratings now serving in H.M.A. Ships and Establishments. Telegrams are to be passed to Navy Office for transmission to Admiralty.

10. Navy Orders 114 of 1941, 127 and 333 of 1942, and 514 of 1943 are cancelled.

(443/203/356.)

(This Order will be reprinted for posting on Notice Boards.)

327.

TELEPHONE TRUNK LINE CALLS BY NAVAL PERSONNEL.

The concession of half rates for telephone trunk line calls from any Post Office where trunk line facilities exist is available to Naval Personnel, including members of the Women's Services.

2. In cases where there is no reasonable doubt that a caller in uniform belongs to the Forces, a trunk line call will be permitted at concession rates without the production of some form of identification, otherwise a leave pass or pay book, in the case of ratings, or a certificate of identity from a ship or establishment, in the case of officers, must be produced.

3. The call must be paid for at the time of booking, and made from the Post Office.

4. Where a group of men visit any centre under the control of an officer or non-commissioner officer, the senior officer shall arrange with the Postmaster concerned to accept cash calls from members at the reduced rate.

5. Where a telephone exchange is not open continuously, no reduction in the usual re-opening fee of 1s. 6d. will be allowed.

6. These concessions extend to private trunk line calls originated by members of the forces from Service clubs established in various parts of Australia under the control of the Australian Defence Canteens Service. Calls will be originated on the club's official telephone service and arrangements for booking, supervision, and payment of calls will be made by the club staff.

7. Navy Orders 193 and 350 of 1941, 344 of 1942, and 491 of 1943 are hereby cancelled.

(622/201/1109.)

(This Order will be reprinted for posting on Notice Boards.)

323.

NAVAL ARMAMENT STORES RETURNED BY H.M.A. SHIPS —VOUCHERING.

Vouchers (Form S.1401) for stores returned direct to a naval armament establishment are in future to be prepared in quadruplicate, for disposal as follows:—

- (a) Original and duplicate forwarded to the naval armament establishment, which will retain the original and return the duplicate receipted.
- (b) Triplicate to be posted in the Ship's ledger and retained on board.
- (c) Quadruplicate to be clearly marked "conveyance note" and handed over with the stores. If all is clear it will be returned receipted by the storehouseman (or other representative receiving the stores), after endorsement as follows:—

"Loose articles and packages received
(contents unexamined)."

2. The quadruplicate copy, received in this manner, should be filed on board with the triplicate copy.

3. Provided the receipt referred to in paragraph 1 is held on the quadruplicate copy, any discrepancies revealed when the duplicate copy is eventually returned receipted will normally be confined to contents of packages.

4. Should time not permit of the preparation of vouchers *before* the stores are landed, an extemporized conveyance note listing the packages and loose articles is to be substituted for the quadruplicate copy and dealt with as indicated for the latter in paragraphs 1 and 2.

5. This Navy Order is a reprint of Admiralty Fleet Order 680/45.

(671/202/775.)

329.

RADAR TYPE A272/A276—LOCAL OSCILLATOR UNIT —MODIFICATION.

Condenser C5, Navy and A.W.A. designation 9049F-179, in figure No. 14/2 of type A272 handbook (A.C.B. 240R) is to be replaced by a Ducon type PT273 condenser. This is a 0.1 mfd. 600-volt type.

2. One No. working condenser Ducon type PT273 and one spare will be supplied by Superintending Naval Store Officer, Sydney, without demand, to all ships fitted with type A272 or A276.

3. The relevant handbook, establishment and spares list will be amended accordingly.

(2037/7/823.)

330.

INCOME TAX.

With reference to paragraph 4 (c) of Navy Order 453 of 1944, the following additional particulars are promulgated for the information of all concerned:—

Deductions allowable.

- (a) *Rebates in Respect of Dependent Wives and Children Overseas.*

Where a member of the Royal Australian Navy marries whilst serving abroad, and his wife is simply remaining outside Australia awaiting arrangements to be made for her passage to rejoin her husband in Australia, the member concerned may claim the concessional rebate in respect of his wife and any children of the marriage, subject to other requirements of the Income Tax Department being complied with. Full particulars of the claim should accompany the Income Tax Return.

- (b) *Taxation of Pay in lieu of Leave and Pay in lieu of Furlough.*

(a) Deferred Pay, Marriage and Dependant Allowances admissible in respect of the grant of pay in lieu of either leave or furlough are exempt from taxation.

(b) Where, however, a member is, upon final discharge from the Royal Australian Navy, granted pay in lieu of leave or furlough, the payment will be treated as a retiring allowance paid in a lump sum, and 5 per cent. only of the Active Pay and Allowance included in the grant will be regarded as assessable income.

- (c) *Superannuation Contributions paid by the Commonwealth—Liability to Tax.*

In any case where superannuation contributions of Commonwealth employees serving in the Forces during the war period are paid by the Commonwealth, the Department of Taxation has decided that the amount of the employee's contributions paid by the Commonwealth to the Superannuation Fund, forms part of the employee's assessable income in the year in which the amount is paid to the Fund.

For the purpose of the allowance of the concessional rebate of tax, the employee, in such cases, will be regarded as having paid the amount of the Superannuation Fund.

- (d) *Special Allowances—Personnel serving in Zones "A" and "B".*

Under a recent amendment of the *Income Tax Assessment Act*, provision is made for special deductions as under:—

- (a) Zone "A". Personnel serving in Darwin and H.M.A.S. *Carpentaria* come within the area prescribed as Zone "A"

and are entitled to a special deduction of £40, provided the member has served in the area for a period of more than one half of the year of income whether continuously or not.

- (b) Zone "B". Personnel serving in Cairns and Townsville come within the area prescribed as Zone "B" and are entitled to a special deduction of £20, provided the member has served in the area for a period of more than one half of the year of income whether continuously or not.

- (c) In any other case (within Zones "A" and "B")—such an amount not being less than Twenty Pounds nor more than Forty Pounds, as, in the opinion of the Commissioner, is reasonable in the circumstances, will be allowed as a deduction.

The Schedule of deductions has been distributed which makes provision for the above special allowances in respect of personnel serving within the prescribed Zones, and deductions should be made in accordance with the scale where necessary.

Personnel serving in Australia outside Zones "A" and "B" are subject to the normal scale of deductions as advised to H.M.A. Depots and Establishments.

(621/201/5979.)

(This Order will be reprinted for posting on Notice Boards.)

331.

TRAVELLING WARRANTS ON DISCHARGE OR DEMOBILIZATION.

Until further notice, Home Leave Passes are to be issued to all personnel on final discharge or demobilization in lieu of Duty Travelling Warrants.

2. Personnel being discharged "Free" or demobilized at own request, may also be issued with Home Leave Passes to convey them to the actual place where they were originally recruited, within the Commonwealth, or to their Port Division as may be elected.

3. The Issuing Authority is to make arrangements to ensure the collection of the Home Leave Pass when the journey has been completed.

4. Naval Financial Regulations and Instructions, Article 175, will be amended in due course.

(632/203/1080.)

REPLACEMENT OF WOODEN FURNITURE BY TUBULAR STEEL FURNITURE—REPORTS.

With reference to Navy Order 354 of 1944, reports as per the Appendix of this Order are to be forwarded as early as practicable to the Superintending Naval Store Officer, Sydney, and a copy to the Director of Naval Stores, Melbourne.

APPENDIX.

Tubular Steel Furniture Received on Board or Outstanding on Demand.		Wooden Furniture Landed in Lieu.		Depot at which Landed and Registered Number of A.S. 331 and Date.	Wooden Furniture Still Remaining on Board.	Anticipated Date of Landing.	Additional Items of Steel Furniture Required (if any) and Reason Therefor.
Pat. No.	Description.	Qty.	Pat. No.	Description.	No.		
R.P. 6	Nesting Chairs						
S.P. 7 or A. 1831	Easy Chairs						
R.P. 18 and S.P. 15 Modified	Arm Chairs Modified						
S. 750	Card Tables						
—	Stools 22" high x 13" diam.						
H.T. 4	Occasional Tables						
S. 2	Settees						

(483/201/4037.)

333.

GRANT FOR TROPICAL OUTFIT.

With reference to Navy Order 77 of 1943, it is notified that officers who were granted a free issue of tropical clothing on first appointment to R.A.N., i.e., Midshipmen, Midshipmen (S), &c., who passed out of the R.A.N. College during the year 1942 and in subsequent years, are not eligible to be paid the grant of £5 towards cost of providing tropical outfit referred to in Navy Order 334 of 1942.

(434/215/1124.)

RESTRICTED.(FOR OFFICIAL USE ONLY.)

Commonwealth Navy Orders.

Navy Office, Melbourne,
7th August, 1945.

The following Orders, having been approved, are hereby promulgated for information and guidance and necessary action.

By direction of the Naval Board,

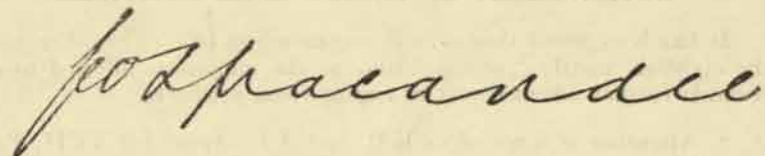

Secretary.

*The Commodore Commanding H.M.A. Squadron,
and Commanding Officers of H.M.A. Ships,
Officers in Charge of H.M.A. Naval
Establishments, and others concerned.*

TABLE OF CONTENTS.

No.	Subject.
334.	Appointments.
335.	Advancement of Engine Room Artificers.
336.	Torpedo Workshop—Pinkenba.
337.	Signals—Indications of Precedence and Their Use.
338.	Publicity—Assistance for War Correspondents.
339.	Boiler Blow-Down System—Alterations and Additions.
340.	Hand Tools—Co-ordination of Common User Items.
341.	Chronometers and Watches for Navigational Use.
342.	Expenditure of Naval Armament Stores—Return of.
343.	Anti-gas Respirators—To be Carried by Personnel on Draft.
344.	Pattern 474 Stretcher Cots—Supply to H.M.A. Ships.
345.	Advances of Cash to H.M. Canadian Ships.
346.	Naval Dockyard Police—Retention of Kit on Discharge.
347.	Airgraph Service.
348.	Installation of General Messing in Small Ships.
349.	Reports of Survey on Provisions or Other Victualling Stores.
350.	Made-to-Measure Uniforms for Ratings—Limitation of Purchases.

334.

APPOINTMENTS.

Commodore J. A. Collins, C.B., assumed duty as Commodore Commanding H.M.A. Squadron and Commander Task Group 74.1, on 22nd July, 1945, *vice* Commodore H. B. Farncomb, C.B., D.S.O., M.V.O.

(1804/2/106.)

335.

ADVANCEMENT OF ENGINE ROOM ARTIFICERS.

It has been noted that certain commanding officers are disregarding the eighteen months "acting" time as the maximum allowed to count towards further advancement of engine room artificers.

2. Attention is directed to K.R. and A.I., Appendix XVII. Part I, 29 (F).

(568/202/1061.)

336.

TORPEDO WORKSHOP—PINKENBA.

A torpedo workshop has been established at Pinkenba, Brisbane.

2. This workshop is capable of carrying out routines on 21-in. Mark IX and 18-in. Mark XV torpedoes and paravanes and of dealing with minor repairs only.

3. The Officer-in-Charge, Pinkenba Torpedo Workshop, is authorized to communicate direct with Director of Ordnance, Torpedoes and Mines, and the Superintendent, R.A.N. Torpedo Factory, on supply and technical matters of a routine nature, subject to K.R. & A.I., Article 875 (2).

4. Communications should be addressed as follows:—

The Officer-in-Charge,

Pinkenba Torpedo Workshop,

c/o Naval Headquarters,

Brisbane.

(443/201/1505.)

337.

SIGNALS—INDICATIONS OF PRECEDENCE AND THEIR USE.

United States Indications of Precedence are in force in the South West Pacific Area.

2. Full instructions, which are contained in D.N.C. 5 (Communications Instructions) Article 2012, 6263, are amplified hereunder, particularly for the originators of signals:—

(a) OPERATIONAL OR ADMINISTRATIVE TRAFFIC.

- (i) In wartime it is necessary to handle operational traffic ahead of all administrative traffic, regardless of the relative precedence assigned.
- (ii) This means that originators must decide in regard to every signal, whether it is *Operational* or *Administrative*. In most cases this decision presents no difficulty, but instances will arise where there is doubt where the line should be drawn. In such cases the general urgency of the message and its bearing, if any, on the successful prosecution of an operation should be borne in mind.

(b) RULES FOR THE ORDER OF PRECEDENCE.

- (i) All *operational* traffic precedes *administrative* traffic.
- (ii) *Operational Priority*.—Operational messages are defined as those affecting or which may affect movements of ships, aircraft, or ground forces within 48 hours.
- (iii) The highest precedence allowed to *administrative* traffic is *priority*.
- (iv) All messages, operational or administrative, must be given the *lowest* precedence necessary to ensure they reach all addresses in time.

(c) DEGREES OF PRECEDENCE.

- (i) There are virtually six degrees of precedence, viz.:—

Operational Traffic—

Order of Precedence.	Signification.	Symbol.
1 ..	Enemy Contact*	.. O.C.*
2 ..	Urgent O.
3 ..	Operational Priority O.P.

Administrative Traffic—

4 ..	Priority P.
5 ..	Routine (R)†
6 ..	Deferred D.

* Only for use within U.S. Navy.

† Only used in multi-precedence messages.

(d) MESSAGE HANDLING.

All sections of the Communication Branch are to ensure that traffic is handled strictly in accordance with the above degrees of precedence.

3. Navy Orders 160 and 163 of 1945 are hereby cancelled.

(2037/2/1352.)

338.

PUBLICITY—ASSISTANCE FOR WAR CORRESPONDENTS.

To assist in obtaining publicity of a desirable type for the work of the Royal Australian Navy, the commanding officer of each cruiser, L.S.(I), destroyer, frigate, *sloop* and *A.M.S. vessel* of the Royal Australian Navy is to detail an officer whose special duty it will be (in addition to his normal duties)—

- (a) to extend guidance and assistance to any war correspondents and/or photographers who may be authorized to visit the ship;
- (b) to assist, if necessary, in arranging despatch of their stories or photographs to the nearest censorship authority for release; and
- (c) to furnish to the Director of Naval Intelligence, Navy Office, Melbourne, or the nearest officer of the R.A.N. Naval Information Section, any material of Naval publicity interest which may arise.

2. Similarly, an officer is to be detailed in each of H.M.A. Naval Shore Establishments where no Staff Officer (Intelligence), or Naval Intelligence Officer is borne; but, where an officer is appointed for intelligence duties, the duties set out in paragraph 1 above are to be allocated to him.

3. The names of the officers selected for these duties are to be reported to the Naval Board as soon as possible.

4. Material—particularly notes regarding censorship procedure—for the guidance of the officers concerned will be forwarded from Navy Office.

5. Navy Order 184 of 1945 is hereby cancelled.

(564/201/453.)

339.

BOILER BLOW-DOWN SYSTEM—ALTERATIONS AND ADDITIONS.

The provisions of A.F.O. 1457/45 are applicable to H.M.A. destroyers, sloops, frigates and A.M.S. vessels.

2. Ships concerned are authorized to raise an alteration and addition item, classification "A," to fit permanent blow-down connections to boilers.

3. This item is to be lettered "BZ" for A.M.S. vessels in accordance with Confidential Commonwealth Navy Order 164 of 1944.

(524/201/1597.)

340.

HAND TOOLS—CO-ORDINATION OF COMMON USER ITEMS.

The instructions contained in A.F.O. 1938/1945 regarding the co-ordination of common user types of hand tools are to be followed in the R.A.N.

2. Particular attention is drawn to the necessity for supplies to be taken on charge and accounted for under the new D.H.T. co-ordinated numbers and for the new numbers to be utilized by all ships, &c., when demanding requirements.

3. Where action may not have already been taken to adopt the new procedure laid down in A.F.O. 916/44, the following should be observed:—

- (i) In cases where the new D.H.T. number supersedes the pattern number, and is not an identical item, e.g., where the pattern number is shown in brackets in A.F.O. 916/44 (e.g., Patt. 5885 Cutters, pipe), a new ledger sheet should be raised for the D.H.T. number, and inserted next to the existing ledger sheet showing the pattern number, which should be marked obsolete and cross referenced to the new sheet containing the superseding item. The new sheet should also show in brackets the Admiralty Pattern Number which has been superseded.
- (ii) In cases where the new D.H.T. number supersedes the pattern number, but where the items are identical (e.g., Patt. 1942 Bevels), the new D.H.T. number and any minor variation in description should be inserted on the existing ledger sheet, and receipts and issues accounted for as formerly.
- (iii) In cases where the item covered by a new D.H.T. number is identical with an existing pattern number, and also replaces other patterns, which are shown in brackets in A.F.O. 916/44 (e.g., Pattern 1523 (1517) Bits Shell $\frac{1}{4}$ -in.), the ledger sheet of the identical pattern number item should be amended as at (ii) above. The ledger sheet of a superseded (but not identical) item, however, should be marked "obsolete" and cross referenced to the D.H.T. number sheet which replaces it, as at (i) above.

(524/214/1182.)

341.

CHRONOMETERS AND WATCHES FOR NAVIGATIONAL USE.

The attention of commanding officers is drawn to the instructions regarding chronometers, chronometer watches and deck watches, as laid down in sections VII and VIII of the Hydrographic Supplies Handbook (H.51). The returns from H.M.A. ships and Authorities are to be rendered promptly when due to the Officer-in-Charge, Hydrographic Branch, 48 Milson-road, Cremorne, N.S.W.

(670/204/653.)

342.

EXPENDITURE OF NAVAL ARMAMENT STORES—RETURN OF.

Rendition of return of expenditure of naval armament stores in accordance with Consolidated Orders and Regulations, Article 377, is suspended during the period of hostilities.

2. Navy Order 255 of 1941 is cancelled.

(480/201/2045.)

343.

ANTI-GAS RESPIRATORS—TO BE CARRIED BY PERSONNEL ON DRAFT.

Reports have been received that ratings on draft arrive without their anti-gas respirators. In the majority of cases, the explanation given is that their respirators are stowed in their kit-bags.

2. The attention of all concerned is to be drawn to the fact that anti-gas respirators are the personal responsibility of the officers or ratings to whom issued, and are to be carried on their persons when travelling, and not stowed in luggage compartments or kit-bags.

3. This instruction is applicable when travelling by air.

4. Navy Order 79 of 1945 is cancelled.

(669/201/1129.)

(This Order will be reprinted for posting on Notice Boards.)

344.

PATTERN 474 STRETCHER COTS—SUPPLY TO H.M.A. SHIPS.

Ships which have not yet complied with Navy Orders 243 and 535 of 1944 regarding the provision of Pattern 474 stretcher cots should forward demands for requirements to the Superintending Naval Store Officer, Sydney, as soon as possible.

(612/235/989.)

345.

ADVANCES OF CASH TO H.M. CANADIAN SHIPS.

Approval is given for supply of Australian currency, as requisite, to be made to H.M. Canadian Ships operating from Australian bases.

2. The requisitions for cash advances should be signed by the supply officer and be approved by the commanding officer. Wherever possible, the application should be prepared and acquittance obtained on Form A.S. 5.

3. Any such advances should be charged to the vote for Other Administrations—Recoverable Expenditure (Canada). The amount of each advance, as made, should be forwarded by signal to Navy Office.

(405/202/553.)

346.

NAVAL DOCKYARD POLICE—RETENTION OF KIT ON DISCHARGE.

The provisions of Navy Order 549 of 1943 relating to retention of kit on discharge are to apply to Naval Dockyard Police personnel as from 1st July, 1945, except that police badges, buttons, and devices, also helmets and cases, are to be recovered in every instance.

(516/201/1636.)

347.

AIRGRAPH SERVICE.

In consequence of the falling off in airgraph traffic, coupled with the increased aircraft accommodation now available for the carriage of overseas mails, acceptance of airgraph letters was discontinued on 31st July, 1945.

2. Navy Order 364 of 1944 is cancelled.

(563/201/2138.)

348.

INSTALLATION OF GENERAL MESSING IN SMALL SHIPS.

With reference to Navy Order 626 of 1944, it is notified that galley charge allowance under Naval Financial Regulations and Instructions, Article 73 (8) (b) (ii), is applicable in the ships concerned as from the date general messing was installed.

(556/226/1891.)

349.

REPORTS OF SURVEY ON PROVISIONS OR OTHER VICTUALLING STORES.

Paragraph 7 of Navy Order 36 of 1945 is to be amended by deleting the words "date of receipt on board" appearing in the fifth line and inserting in lieu thereof the words "age and condition."

(612/243/975.)

350.

MADE-TO-MEASURE UNIFORMS FOR RATINGS—LIMITATION OF PURCHASES.

The contractors for ratings' made-to-measure uniforms are finding it extremely difficult owing to shortage of man power, and increasing civilian demands due to demobilization, to cope with orders placed by ratings. In this connection the Sydney contractor, Messrs. David Jones Ltd., Marlborough-street, Surry Hills, has already advised that further orders cannot be accepted until 30th September, 1945.

2. It is, therefore, necessary, whilst the present situation continues, that ratings should take all possible steps to prolong the life of any made-to-measure garments which they now possess, and arrange to replace only those articles which are essential to meet Service requirements.

3. Before issuing Forms A.S. 87x—"Authorities to Supply Made-to-Measure Uniform Clothing" (*vide* Navy Order 630 of 1944)—Supply and other Officers concerned are to satisfy themselves by inquiry that supply is essential and that suitable stock-size garments are not available.

(434/216/113.)

*(This Order will be reprinted for posting on Notice Boards.)*RESTRICTED.

351-361/45.

(FOR OFFICIAL USE ONLY.)**Commonwealth Navy Orders.**

Navy Office, Melbourne,

14th August, 1945.

The following Orders, having been approved, are hereby promulgated for information and guidance and necessary action.

By direction of the Naval Board,

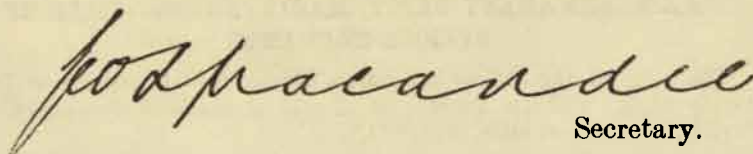

Secretary.

*The Rear-Admiral Commanding H.M.A. Squadron,
and Commanding Officers of H.M.A. Ships,
Officers in Charge of H.M.A. Naval
Establishments, and others concerned.*

TABLE OF CONTENTS.

No.	Subject.
351.	Appointments.
352.	R.A.N. Armament Depot, Maribyrnong—Title of Officer-in-Charge.
353.	Transfer of "Hostilities Only" Ratings to the Permanent Naval Forces.
354.	Examination of Engine Room Ratings—March, 1945.
355.	Landing of Firearms in Australia.
356.	American 20-mm. Ammunition Assembled with Defective Primers—Unserviceable Lots.
357.	Offences of Breaking Out of Ship—Mulcts.
358.	Motor Launch Issued on Loan to H.M.A.S. "Swan"—Disposal.
359.	Lists of Naval Stores on Permanent Loan, Inventory Naval Store Accounts of M.L's. and Small Craft, Accounts of Permanent Naval Stores in Auxiliary Vessels—Forms A.S. 1099 (Outside) and (Inside) and A.S. 1099B.—Revision.
360.	Department of the Navy—H.M.A. Naval Dockyard Williamstown—Vacancy.
361.	Books and Forms.

Library

351.

APPOINTMENTS.

Acting Rear-Admiral George D. Moore, C.B.E., has been appointed Acting First Naval Member (temporarily).

2. Commodore H. B. Farncomb, C.B., D.S.O., M.V.O., has been appointed Flag Officer-in-Charge Sydney (temporarily), in the rank of Commodore First Class.

3. Appointments are to date 2nd August, 1945.

(404/202/974.)

352.

R.A.N. ARMAMENT DEPOT, MARIBYRNONG—TITLE OF OFFICER-IN-CHARGE.

The title of the Officer-in-Charge of the Naval Armament Depot, Maribyrnong, will in future be Naval Armament Supply Officer, Maribyrnong (short title, N.A.S.O.).

(404/201/731.)

353.

TRANSFER OF "HOSTILITIES ONLY" RATINGS TO THE PERMANENT NAVAL FORCES.

The Naval Board have under consideration the requirements of personnel for the Post-War Establishment, and have decided as a first step to call for volunteers from men now serving in the Navy as 'Hostilities Only' ratings to transfer to the Permanent Naval Forces, if and when required.

For the purpose of this Order, the term "Hostilities Only ratings" means R.A.N.R. and R.A.N.V.R. ratings, and R.A.N. ratings entered specifically for a period of two years or the duration of the war and six months thereafter whichever is the longer.

2. CONDITIONS OF TRANSFER.

(a) *Period of Engagement.*—Where approval is given to transfer under this Order, the rating will be given the option of—

(i) engaging for a period of 12 years' service from the date of transfer; or

(ii) engaging from the date of transfer for the period necessary to complete 12 years' service from the date of mobilization or date of reaching the age of 18 years, whichever is the later.

(b) *Rating and Seniority.*—Where approval is given to transfer, the member will be permitted to retain his existing rating and seniority, provided that retention of any temporary higher rating granted under the provisions of Navy Order 276 of 1940 shall be subject to—

(i) appropriate vacancies existing in the permanent establishment; and

(ii) possession by the member of the full qualifications for such higher rating.

(c) *Deferred Pay.*—Reserve ratings transferred to the Permanent Naval Forces (Sea-going) under this Order will be paid all deferred pay due to them at the date of transfer.

(d) *General.*—The conditions governing service generally of personnel already serving in the permanent service will apply to transferees to the Permanent Naval Forces under this Order.

3. The branches in which transfers will be permitted will be promulgated as soon as the size and composition of the post-war Navy has been decided.

4. The names of volunteers who are desirous of transfer should be forwarded to the Naval Officer-in-Charge, Flinders Naval Depot.

(630/201/39.)

(This Order will be reprinted for posting on Notice Boards.)

354.

EXAMINATION OF ENGINE ROOM RATINGS—MARCH, 1945.

With reference to Navy Order 299 of 1945, the following additional results are promulgated:—

ACTING E.R.A. 4TH CLASS FOR CONFIRMATION.

O.N.	Name.	Present Rating.	Application Received From.	Result.
PA/2544 PM/6880	Giesecke, R. M. . . Johnson, L. F. . .	E.R.A., a/4	Cape Leeuwin .. Strahan ..	Passed Supr.] Passed Sat.]

(465/207/1260.)

355.

LANDING OF FIREARMS IN AUSTRALIA.

It has been established that Service weapons of both Allied and enemy origin have been concerned in a number of recent murders and shootings in Australia.

2. It has been suggested that arms find their way into the country in the following ways:—

- (a) Being brought in as souvenirs by Service personnel returning from battle areas.
- (b) In parcels, sent as souvenirs, to friends or relatives.
- (c) By aircrews arriving from forward areas.
- (d) By crews of merchant vessels which visit forward areas.
- (e) By an evidently organized system of inclusion in supposedly empty packages for return to the mainland.

3. Commanding officers are to take any steps they consider necessary to ensure that officers and men do not bring or send any machine gun, sub-machine gun, concealable firearm or any type of ammunition into Australia. Attention is also drawn to the necessity for strict compliance with the orders for issue, return, safe custody and transport of small arms.

(412/201/96.)

356.

AMERICAN 20-MM. AMMUNITION ASSEMBLED WITH DEFECTIVE PRIMERS—UNSERVICEABLE LOTS.

Reports have been received that the following American 20-mm. ammunition has been found to be defective due to the rupturing of the anvils of the primer Mark 31.

Parts of these ruptured anvils occasionally lodge in the bore and frequently cause the next round to detonate prematurely in the barrel.

- (a) 20-mm. A.A. H.E.T. cartridges assembled by National Fireworks Company, Incorporated, West Hanover, Mass. (1944).

ZB-122-NFH-44 through 127, 130 through 132, 135, 138, 203 through 209, 221, 237, 243, 272 through 276, 293, 316.

- (b) 20-mm. A.A. H.E.I. cartridges assembled by National Munitions Corporation, Carrboro, North Carolina (1944).

ZC-213-NMC-44 through 218, 220, 221, 296 through 368, 402 through 408, 410.

- (c) 20-mm. A.A. H.E.T. cartridges assembled by National Fireworks, Incorporated, Chillicothe, Ohio (1944).

ZB-115-NFCH-44, 116, 119 through 128, 135 through 139, 150 through 274, 296 through 304.

- (d) 20-mm. A.A. H.E.I. cartridges assembled by National Fireworks, Incorporated, Chillicothe, Ohio (1944).

ZC-160-NFCH-44, 162, 164, 166 through 174, 176, 177, 179, 181, 183, 185, 187, 190, 192, 194, 196, 198 through 201, 203, 205, 207, 209, 211, 216, 224, 226, 228, 230, 232, through 411, 413, 415, 417, 419, 421, 423, 451, 454, 463, 505.

- (e) 20-mm. A.A. H.E.T. cartridges assembled by Bermite Powder Co., Saugus, California (1944).

ZC-47-BPC-44, 49 through 77, 89, 95, 98 through 197, 205 through 210, 214 through 225, 234 through 311.

- (f) 20-mm. A.A. H.E.T. cartridges assembled by National Fireworks, Incorporated, Cordova, Tenn. (1944).

ZB-71-NFC-44 through 84, 134, 135, 137, 138, 140, 143, 145, 146, 147, 149 through 157, 191 through 206, 208 through 235, 238, 248, 252, 288, 289, 291 through 296, 298 through 308, 312, 335, 413 through 439, 441 through 464, 499 through 501, 606, 608 through 620.

- (g) 20-mm. A.A. H.E.T. cartridges assembled by National Fireworks, Incorporated, Bristol, Va. (1944).

ZB-82-NFB-44 through 84, 87, 92, 97, 102 through 111, 113 through 130, 132, 137, 138, 140 through 212, 228 through 238, 240, 242 through 249, 255, 256, 259, 260, 262 through 266.

- (h) 20-mm. A.A. H.E.I. cartridges assembled by National Fireworks, Incorporated, Bristol, Va. (1944).

ZC-169-NFB-44 through 177, 200, 201, 203 through 206, 208, 211 through 213, 215, 217 through 247, 250, 252, 254 through 256, 260, 262 through 273, 280 through 328, 336 through 339, 342 through 376, 378 through 405, 409, 412, 413, 417, 446, 448 through 453, 456 through 459, 462 through 466, 471, 490, 495, 497 through 504, 506, 510 through 515, 521, 522, 524, 528, 531, 533.

- (i) 20-mm. A.A. H.E.I. cartridges assembled by Victory Ordnance Corporation, Peru, Ind. (1944).

ZC-6-VO-44, 7, 43 through 50, 101 through 132, 134 through 151, 155, 157 through 184, 196 through 202, 205 through 207, 210 through 215.

- (j) 20-mm. A.A. H.E.I. cartridges assembled by National Fireworks, Incorporated, Elkton, Maryland (1944).

ZC-117-NFE-44 through 119, 121 through 124, 132, 133, 135, 139, 140, 142, 143, 148.

2. Any ammunition of the lots listed above, on board ships, is to be landed at the first opportunity and serviceable ammunition drawn in lieu. All boxes should be tagged "For Rework—Defective Primers", prior to being landed.

3. Depots are to report for disposal quantities of any such ammunition received.

(408/206/1586.)

357.

OFFENCES OF BREAKING OUT OF SHIP—MULCTS.

The following ruling concerning the remission of mulcts for offences of breaking out of a ship, is promulgated for information and guidance:—

“Although offences of breaking out of ship and absence without leave fall under different sections of the Naval Discipline Act, it has been decided that the two offences are so closely linked, in that a man cannot break out of ship without remaining absent without leave, that the ordinary rules for remission of mulcts (K.R. & A.I. Article 578, clause 5) should apply.”

(452/201/2108.)

358.

MOTOR LAUNCH ISSUED ON LOAN TO H.M.A.S. “SWAN”—DISPOSAL.

The under-mentioned motor launch was issued on loan to H.M.A.S. *Swan* from Garden Island in November, 1942. The launch, however, is not now held by H.M.A.S. *Swan* and no record of disposal can be traced:—

Chapman pup motor launch—clinker built, kauri planking, fitted with Chapman master pup engine, also monel metal lifting rings fore and aft. Length 16 ft. 6 in. Beam 5 ft. 4 in. Moulded depth 2 ft. 4 in. No registered number but letter “H” cut in bow.

2. Any information available in any ship or establishment as to whereabouts or disposal of this launch should be forwarded to Navy Office.

(603/246/4837.)

359.

LISTS OF NAVAL STORES ON PERMANENT LOAN, INVENTORY NAVAL STORE ACCOUNTS OF M.Ls. AND SMALL CRAFT. ACCOUNTS OF PERMANENT NAVAL STORES IN AUXILIARY VESSELS—FORMS A.S.1099 (OUTSIDE) AND (INSIDE) AND A.S.1099B—REVISION.

The present Permanent Loan List Forms A.S.1099 (outside) and (inside) and A.S.1099B have been revised to provide a standard form for the following purposes:—

- (a) Lists of naval stores on permanent loan (see B.R. 4, Article 50).
- (b) Inventory accounts of permanent naval stores for M.Ls. and other small craft and stations or services attached to H.M.A. depots and bases (see Navy Orders 632 and 682 of 1943).
- (c) Accounts of permanent naval stores (inside sheets only) in H.M.A. auxiliary vessels.

2. It is not intended that current permanent loan lists, &c., should be replaced, but all new permanent loan lists, inventory naval store accounts, and accounts of permanent naval stores should be prepared on the new forms, stocks of which are available from the Superintending Naval Store Officer, Sydney.

3. With regard to sub-paragraph (c), in view of the number of sheets (including Account of Stock and Receipt of Consumable Stores Forms) required to be kept in the one cover, the present covers A.S.154 should continue to be used for these accounts.

(480/202/4705.)

360.

DEPARTMENT OF THE NAVY—H.M.A. NAVAL DOCKYARD WILLIAMSTOWN—VACANCY.

Applications are invited from suitably qualified persons desirous of appointment as Superintendent of Stores and Transport (Temporary), H.M.A. Naval Dockyard, Williamstown.

2. The salary scale of the position will be with a minimum of £522 and a maximum of £594 plus cost of living allowance (at present £40 per annum). Actual commencing salary will be determined according to experience and qualifications.

3. Applicants should possess initiative and organizing ability. Experience, preferably in respect of Commonwealth procedure, in the purchase, handling, receipt, custody and issue of stores, also in transport matters, is essential.

4. Applications, stating age, qualifications, experience and particulars of service should be submitted to Commanding Officers for urgent transmission to the Secretary, Naval Board.

5. Copies of testimonials, if available, should be enclosed with applications.

(406/201/444.)

361.

BOOKS AND FORMS.

First supplies of the under-mentioned publications have been distributed:—

Addendum No. 1 to B.R. Form U.2.D.—Regulations for the Security of Top Secret, Secret, Confidential and Restricted Books, Documents and Charts.

(A.F.O. 1906/45.)
(480/201/3444.)

B.R.70.—Signal Letters of British Ships—September, 1944, Supplement.

(A.F.O. 985/45.)
(571/202/2042.)

B.R.268(1).—Electrical Manual, Volume II—Pamphlet on Telephones.

(A.F.O. 1780/45.)
(571/202/2040.)

B.R.317(28).—Mining Drill Book—Preparation of the Mark XV and XVII* Sinkers Assemblies 1 to 26.

(A.F.O. 1623/45.)
(571/202/1970.)

Errata No. 13 to B.R.368 and Form D.129.—Establishment of Naval Stores for Sloops, Corvettes (*Kittiwake*, &c., types), &c., and Form D.129, List of Particulars.

(A.F.O. 5705/44.)
(571/202/1548.)

Errata No. 5 to B.R.375(5).—Establishment of Naval Stores for Fast Minelayers.

(A.F.O. 347/45.)
(571/202/2136.)

B.R. 446B.—My Prayer Book for Women and Girls.

(A.F.O. 2790/43.)
(571/202/2157.)

B.R.634.I.—Dictionary of Naval Equivalents—Italian-English.

(A.F.O. 6086/42.)
(571/202/2156.)

B.R.647/44.—Drill for 2 pdr. Mark VIII Guns on Mark VII, VII*P and R.P. 50 Mark VII Mountings.

(A.F.O. 984/45.)
(571/202/1707.)

B.R.811.—Aircraft Torpedo Manual Part III, Pamphlets Nos. 4, 2A, 5, 3B, 9 and 1G.

(A.F.O's 4427/44, 474 and 1490/45.)
(571/202/2046.)

B.R.1063.—Depth Charge Pocket Book.

A.F.O. 1490/45.)
(571/202/2162.)

B.R.1077A.—Index to B.R. 1077—Regulations and Instructions for W.R.N.S.

(A.F.O. 1490/45.)
(571/202/2107.)

B.R.1081.—Instructions for Classification in Age and Service Groups.

(A.F.O. 6512A.)
(571/202/2038.)

B.R.1082.—Drill for 40 mm. U.S. Mark I Guns on U.S. Quadruple Mark II Mountings.

(A.F.O. 6771/44.)
(571/202/2167.)

B.R.1086(C).—Coastal Forces Gunnery Handbook, Volume III, Gun Drills in Coastal Force Craft.

(A.F.O. 1490/45.)
(571/202/2161.)

B.R.1205.—Preliminary Pamphlet for the Gyro Gun Sight, Type 6, Mark II.

(A.F.O. 620/45.)
(571/202/2139.)

B.R.1230(1)/1944 (Supersedes O.U.6341(3)).—Regulations for Maintenance of 18-in. L.C. Marks II-II* Torpedo Tubes (Power Impulse) in M.T.Bs.

(A.F.O. 1906/45.)
(571/202/2169.)

B.R.1233.—Japanese Morale.

(A.F.O. 621/45.)
(571/202/2140.)

B.R.1239.—Arterial Injuries—Early Diagnosis and Treatment.

(A.F.O. 350/45.)
(571/202/2127.)

W/T Frequency Supplements—Series XI to 4/M.350 for August, September and October, 1945.

(A.F.O. 1366/45.)
(571/202/2016.)

Services Index of Valves, C.R. Tubes and Electronic Devices—Short Title S.I.V.C.R.E.D., December, 1944.

C.V. Register of Electronic Valves, June, 1944.

(571/201/4480.)

Aircraft Recognition Journal Volume III, Nos. 1-7, October, 1944, to March, 1945.

(A.F.Os. 6771/44 and 1490/45.)
(415/201/1879.)

2. The latest Admiralty revision of the under-mentioned form has been adopted for use in the R.A.N. Supply will be effected, on demand, by the Superintending Naval Store Officer, Sydney, when stock of the existing form is exhausted:—

S.313 (Revised June, 1942).—Report concerning Loss or Failure of Paravane Equipment.

(480/202/4734.)

3. The under-mentioned form has been introduced for use in the R.A.N. in lieu of the corresponding Admiralty form. Supply will be effected, on demand, by the Superintending Naval Store Officer, Sydney, when stock of the existing form is exhausted:—

A.S.1246K.—Cook Ratings History Sheet.

(480/202/4727.)

4. The under-mentioned form has been introduced for use in the R.A.N. First supply will be effected, without demand, by the Medical and Dental Store Officer, Sydney:—

A.M.2y.—Leaflet “How to Prevent Malaria Relapses.”

(527/201/1022.)

5. The under-mentioned form has been revised. Distribution of first supply will be effected, without demand, by the Superintending Naval Store Officer, Sydney:—

A.T.801z.—Issue of Mess Gear and Blankets to Naval Personnel Travelling.

(C.N.O. 234/45.)

(480/201/3261.)

6. The under-mentioned form has been adopted for use in the R.A.N. Replenishments will be effected, on demand, by the Superintending Naval Store Officer, Sydney:—

M.S.5.—Merchant Ship War Radio Call Sign.

(480/201/3543.)

RESTRICTED.(FOR OFFICIAL USE ONLY.)

Commonwealth Navy Orders.

Navy Office, Melbourne,
21st August, 1945.

The following Orders, having been approved, are hereby promulgated for information and guidance and necessary action.

By direction of the Naval Board,

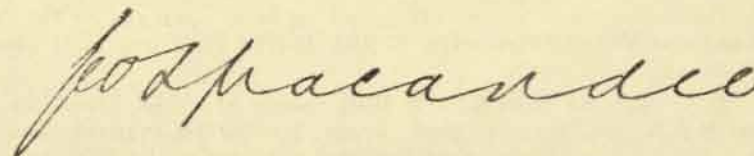

Secretary.

*The Commodore Commanding H.M.A. Squadron,
and Commanding Officers of H.M.A. Ships,
Officers in Charge of H.M.A. Naval
Establishments, and others concerned.*

TABLE OF CONTENTS.

No.	Subject.
362.	Correction of Admiralty Charts in H.M.A. Ships.
363.	Base A/S Staff Organization.
364.	Customs Treatment of Goods Brought Back to Australia by Returning Australian Servicemen.
365.	Failures of Gun Armament Material and Ammunition—Rendering of Forms S.1148 and Return of Defective Stores.
366.	Machinery's Handbook, 1943—By Erik Oberg and F. D. Jones—Issue on Repayment.
367.	Appointment of Visual Education Officer—Film Section—Commonwealth National Library.
368.	Flour.

362.

CORRECTION OF ADMIRALTY CHARTS IN H.M.A. SHIPS.

The instructions contained in King's Regulations and Admiralty Instructions, Articles 1198 and 1199, Consolidated Orders and Regulations, Article 355, the Hydrographic Publication H.51, "Handbook on the Supply and Correction of Admiralty Charts, Sailing Directions, &c.," and the front page of all weekly editions of Notices to Mariners issued by the Department of the Navy are to be strictly complied with.

2. It is essential that all Navigational Charts be corrected as soon as Notices to Mariners are received on board. The danger of navigating with charts which are not corrected up to date is particularly impressed on all concerned.

3. When it is necessary to transfer chart folios or loose charts to a chart depot, or from one navigation officer to another, a report is to be included stating the number of the last Notices to Mariners for which charts have been corrected.

4. Navy Order 101 of 1943 is cancelled.

(453/203/1389.)

363.

BASE A/S STAFF ORGANIZATION.

The instructions which follow, having been approved by the Naval Board and Vice-Admiral (Q), British Pacific Fleet, are to be observed by all concerned.

2. At ports where R.N. A/S Maintenance Staffs are borne, the R.N. and R.A.N. Staffs are to work as one, pooling all available resources. In matters of local administration and port duties the R.N. base A/S Maintenance Officers are to be guided by the instructions of:—

(a) The Commanding Officer, H.M.A.S. *Rushcutter*, at Sydney.

(b) The local Naval Officer-in-Charge at other ports.

3. The Base Staff will be responsible for the maintenance of all A/S equipment (Asdics, echo sounding and hydro-phones) in H.M., H.M.A. and Allied (except U.S.N.) ships based at, or visiting a port, except as laid down in paragraph 5.

4. The Senior Officer of the Base Staff will be responsible that the above work is carried out, through his respective Naval Officer-in-Charge, to the Australian Commonwealth Naval Board and the Vice Admiral (Q), with the exception of Sydney where the Base Staff will work under the orders of the Commanding Officer, H.M.A.S. *Rushcutter*, who will be responsible, through the Flag Officer-in-Charge, Sydney, to the Australian Commonwealth Naval Board and the Vice Admiral (Q).

5. When a specialist A/S Officer (or A/S Maintenance Officer) on the staff of a ship's administrative authority is present, he will be responsible for the maintenance of the A/S equipment in that ship, unless the administrative authority requests the base staff to undertake the work.

6. All correspondence, signals and reports are to be originated in the name of the local administrative authority.

7. A report is to be rendered by the administrative authority on the first of each month to the Australian Commonwealth Naval Board and the Vice Admiral (Q), copy to Commanding Officer, H.M.A.S.

Rushcutter, of all fittings and maintenance work completed, and work taken in hand, in the area for which the Base Staff is responsible. Where applicable, reports should be divided into three parts:—

- (a) H.M. Ships.
- (b) H.M.A. Ships.
- (c) Allied Ships.

Special reports are also required on any components which are a continual source of trouble, or on defects contributable to climatic conditions.

8. Ships requiring the assistance of the Base A/S Staff are to apply to:—

- (a) H.M.A.S. *Rushcutter* (info. F.O.I.C. Sydney)—at Sydney.
- (b) Local Naval Officer-in-Charge—at other ports.

9. These instructions form the subject of Royal Naval Temporary Memorandum (A) 135.

(1903/2/1206.)

364.

CUSTOMS TREATMENT OF GOODS BROUGHT BACK TO AUSTRALIA BY RETURNING AUSTRALIAN SERVICEMEN.

Import licences will be issued, where required, for any goods which returning Australian Servicemen may bring back with them, provided such goods are not intended for sale or exchange.

2. The grant of an import licence does not, of course, exempt the goods from any Customs duty that may be payable. A special concession has been made to members of the Forces enabling them to bring back goods (other than tobacco and spirituous liquors) to the value of £10 without payment of duty. However, where the value of the goods exceeds £10, duty is payable at the same rates as if the goods had been imported commercially.

3. The duties applicable to items such as complete motor cars or radio sets are high and personnel who may be contemplating importing such goods are advised to study the duty of such items before making any decision.

4. The Australian Customs Representatives at Australia House, London, and at 630 Fifth-avenue, New York, are in a position to advise Servicemen on questions of duty.

(612/250/233.)

365.

FAILURES OF GUN ARMAMENT MATERIAL AND AMMUNITION—RENDERING OF FORMS S.1148 AND RETURN OF DEFECTIVE STORES.

Confusion and delays are being experienced due to Naval Armament Stores, landed because of reports of failures of gun armament material and/or ammunition, not bearing any label or marking to identify the store or package with the relevant Form S.1148.

2. Failure to endorse forms and labels with ships' serial numbers is also adding to this confusion.

3. Attention is called to Admiralty Fleet Order 82A/1942, Navy Order 421 of 1944, and B.R. 862, Naval Magazine and Explosives Regulations, Article 318.

(480/202/4757.)

366.

MACHINERY'S HANDBOOK, 1943—BY ERIK OBERG AND F. D. JONES—ISSUE ON REPAYMENT.

Copies of this publication are available for issue on repayment, within the Service, at £1 per copy now that a later edition has been issued. Demands by H.M.A. Ships and Naval Establishments for copies required for issue accordingly, should be forwarded to the Superintending Naval Store Officer, Sydney, (Stationery Section, 4-16 Yurong-street) as soon as possible.

2. When desired, the full charge may be made in the ship's ledger accounts of ratings, and be recovered in four fortnightly payments.

(571/201/4276.)

367.

**APPOINTMENT OF VISUAL EDUCATION OFFICER—FILM SECTION
—COMMONWEALTH NATIONAL LIBRARY.**

Applications are invited from male persons 21 years of age and over for temporary employment to the above position. Actual salary payable is minimum, £574, and maximum, £646 per annum. Commencing salary within the above range will be dependent upon the qualifications of the successful applicant.

2. Qualifications:—Applicants should be graduates of a recognized Australian or other approved University. Preference will be given to applicants with experience in visual education or educational research duties. The National Library's responsibility will be in carrying out the policy of the National Film Board in the acquisition and distribution within Australia of documentary and educational films and other aids to visual education; the appointee will be required to undertake the appraisal and assist in organizing the distribution of this material.

3. Preference will be given to persons with the necessary qualifications who have been members of the Forces.

4. Applications stating full name, date and place of birth, war service (if any) and qualifications, should be lodged with the Librarian, Commonwealth National Library, Parliament House, Canberra, not later than Thursday, the 30th August, 1945.

(712/205/497.)

368.

FLOUR.

Supplies of jute are now available for packing flour in 150-lb. sacks. Flour packed in 150-lb. jute sacks as well as the 50-lb. pack in calico or hessian bags will therefore be available on demand from Royal Edward Victualling Yard and H.M.A. Naval Victualling Depots in future.

2. Navy Order 132 of 1943 is hereby cancelled.

(668/207/221.)

RESTRICTED.(FOR OFFICIAL USE ONLY.)

Commonwealth Navy Orders.

Navy Office, Melbourne,

28th August, 1945.

The following Orders, having been approved, are hereby promulgated for information and guidance, and necessary action.

By direction of the Naval Board,

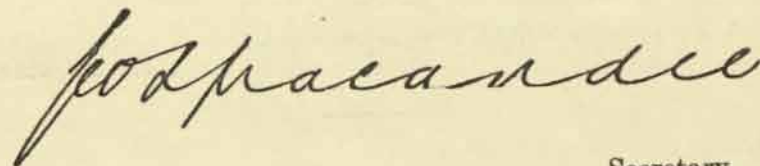

Secretary.

*The Commodore Commanding H.M.A. Squadron,
and Commanding Officers of H.M.A. Ships,
Officers in Charge of H.M.A. Naval
Establishments, and others concerned.*

TABLE OF CONTENTS.

No.	Subject.
369.	H.M.A.S. "Ladava"—Naming.
370.	Release of Personnel for Dairying Industry.
371.	Modification to Tumbler Mark IV D.C. Throwers.
372.	Darwin Naval Base—Organization.
373.	Corrigendum.

369.

H.M.A.S. "LADAVA"—NAMING.

With reference to Navy Order 177 of 1943, "D" Boat No. 111, has been renamed H.M.A.S. *Ladava*.

(404/201/557.)

370.

RELEASE OF PERSONNEL FOR DAIRYING INDUSTRY.

The Manpower position for the dairying industry is no longer acute and special consideration will no longer be given to applications for release to return to this industry. Such applications will be considered in conjunction with other occupational releases.

2. Navy Order 304 of 1944 is cancelled.

(535/203/240.)

371.

MODIFICATION TO TUMBLER MARK IV D.C. THROWERS.

With reference to A.F.O. 6560/44, the modification referred to will be carried out by R.A.N. armament depots or by base staff at refitting ports.

2. Ships concerned are to make a notation to this effect in their next lists of alterations and additions.

3. Navy Order 207 of 1945 is cancelled.

(471/205/2524.)

372.

DARWIN NAVAL BASE—ORGANIZATION.

With reference to Navy Order 235 of 1945, paragraph (e) is to be amended to read as follows:—

"(e) Shore establishments other than the Boom Defence Depot, the Naval Store Depot, and the Naval Victualling Depot are administered by the Commanding Officer, H.M.A.S. *Melville*."

(409/201/3071.)

373.

CORRIGENDUM.

With reference to Navy Order 345 of 1945—"Cash Advances to H.M. Canadian Ships"—paragraph 3 is to be amended by deleting the word "forwarded" in the last line, and inserting in lieu the word "reported".

RESTRICTED.(FOR OFFICIAL USE ONLY.)**Commonwealth Navy Orders.**

Navy Office, Melbourne,
4th September, 1945.

The following Orders, having been approved, are hereby promulgated for information and guidance, and necessary action.

By direction of the Naval Board,

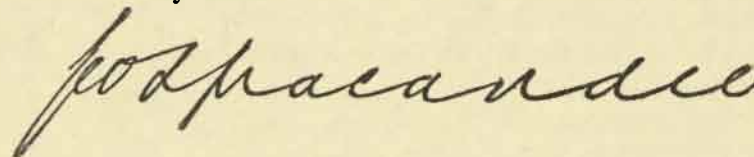

Secretary.

*The Commodore Commanding H.M.A. Squadron,
and Commanding Officers of H.M.A. Ships,
Officers in Charge of H.M.A. Naval
Establishments, and others concerned.*

TABLE OF CONTENTS.

No.	Subject.
374.	Appointment of Medical Editor.
375.	R.A.N. Damage-Control and Fire-fighting School.
376.	W.R.A.N.S.—Advancement to Chief Petty Officer Wrn.
377.	Examination of Sick Berth Staff, May, 1945.—Results.
378.	Naval Censorship.
379.	A.M.S. Vessels—Magazine Battens—Reports.
380.	Ready Use Lockers Pattern 7152—Modification for Stowage of Boxed Bofors Ammunition.
381.	Internal Combustion Engines—Starting Gear—Precautions.
382.	Telescopes Gun-sighting Patts. G.A.100 and G.A.100*—Issue of, Instead of Other Patterns.
383.	Dependant Allowance for Children over 16 Years Receiving Full Time Education.
384.	Cash Advances in American Currency from British Pacific Fleet Units to R.A.N. Accounting Authorities—Rate of Exchange.
385.	Lodging Allowance.
386.	Kit Bags, Hammocks, &c.—Losses during Transport—Labelling and Marking.
387.	Empty Ammunition Packages—Return of.
388.	Fourth Victory Loan.
389.	Corrigenda.

374.

APPOINTMENT OF MEDICAL EDITOR.

Colonel Allan Seymour Walker has been appointed Medical Editor of the Official History of Australia in the present war, in succession to the late Major-General R. M. Downes.

2. All necessary facilities should be given to Colonel Walker.

(580/201/181.)

375.

R.A.N. DAMAGE-CONTROL AND FIRE-FIGHTING SCHOOL.

A Damage-Control and Fire-fighting School for the training of officers and ratings has been set up as part of the establishment of H.M.A.S. *Penguin* (Balmoral Naval Depot). The School is for use of the R.A.N. and the British Pacific Fleet.

2. Courses:—

(i) *Damage-control—Officers*—Limited to 30.

(ii) *Damage-control—“Key” Ratings*—Limited to 30.

These Courses run alternately commencing at 0845 on Wednesdays with a 3 days' Fire-fighting Course and continuing from 0845 Monday to 1130 Saturday the following week. (Officers and “Key” ratings are required to do this Preliminary Fire-fighting Course, unless this has been done within the past 12 months.)

(iii) *Fire-fighting—1-Day Course*.—Officers and ratings—limited to 30.

(iv) *Fire-fighting—Advanced Course*.—Officers and selected ratings—limited to 30.

A two-days' course commencing at 0845, Mondays and Tuesdays only. This course is for officers and ratings who have done the 1-day course.

3. The syllabus of the courses follows closely that of the British Damage Control schools and Fire-fighting schools. American and Australian equipment is included.

4. Applications for courses should be made to H.M.A.S. *Penguin*. Applications from shore establishments should be made at least seven days before the commencement of the courses required. Applications from ships should be made as early as possible to enable preference to be given them. Preliminary inquiries may be made by telephone to the school—Number XM3021, Extension 72.

5. Accommodation for a limited number of key ratings is available in H.M.A.S. *Penguin*. If accommodation is desired it should be stated in the application. There is no accommodation available for officers. Ratings who are not accommodated should bring bag dinners. Officers' and ratings' Fire-fighting classes should bring overalls, soap and towels. Washing facilities are available, including hot and cold showers. Oilskins and sea boots can be provided at the school.

(614/201/91.)

376.

W.R.A.N.S.—ADVANCEMENT TO CHIEF PETTY OFFICER WRAN.

The qualifications and the procedure for advancement of W.R.A.N.S. ratings (in all categories) to the rating of Chief Petty Officer Wran shall be as follows:—

(a) Length of Service.—Twelve months' service as Petty Officer Wran in the category in which advancement is recommended.

(b) Conduct.—Two years' “V.G.” conduct immediately preceding the recommendation.

(c) Professional Qualifications.—A written examination is not required. A candidate must be recommended by the Officer-in-Charge of the Section in which she is employed, and appear before a Selection Board consisting of the Commanding Officer, the Base Supply Officer and the Executive Officer, W.R.A.N.S., who will make the final recommendation to the Naval Officer-in-Charge, Flinders Naval Depot, whether the candidate's name is to be included in the roster for advancement.

(d) The Officer-in-Charge of the Section, when making a recommendation to the Selection Board, must be satisfied that the rating has maintained the theoretical knowledge required to pass the professional examination for the Petty Officer rate, and is able to apply it to good practical effect.

(e) The Selection Board, before making its recommendation, must be satisfied that the rating possesses qualities of leadership, initiative, resource, tact and industry well above the average, and is likely to make a good Chief Petty Officer Wran.

(f) The number of Chief Petty Officer Wrans allowed in each establishment (grouping all categories) is not to exceed the proportion of one C.P.O. Wran to four P.O. Wrans. The overall proportion of higher Wran ratings, appearing in Navy Order 259 of 1945, paragraph 2, shall therefore become—

1 Chief Petty Officer Wran.

4 Petty Officer Wrans.

8 Leading Wrans.

36 Wrans.

(g) The recommendations of each Selection Board are to be forwarded quarterly, commencing 30th September, 1945, on Form A.S.507, to the Naval Officer-in-Charge, Flinders Naval Depot.

(432/224/1272.)

EXAMINATION OF SICK BERTH STAFF, MAY, 1945.—RESULTS

The results obtained by candidates who passed in the examination for advancement in the Sick Berth Branch, held on 29th May, 1945, are as given hereunder:—

Examination Number.	Name	Pre-n. Rating.	O. N.	Percentage of Marks Obtained in Examination			Where Serving at Time of Examination.
				Paper No. 1	Paper No. 2	Written (Average Percentage)	
2)	Lane, A. R.	A/SBPO	PM/2407	72	81	74.5	Passed
1)	Binks, R.	L/SBA	S/3818	90	77	83.5	Passed
12)	Robb, J. E.	L/SBA	22582	91	90	91.5	Passed
63)	Kelly, V. J.	L/SBA	PM/2112	78	66	72	Passed
11)	Nicholson, B. B.	SBA	PM/7538	90	79	81.5	Passed
33)	Davey, C. W.	SBA	PM/5337	79	72	75.5	Passed
33)	Gilmore, H. T.	SBA	24190	68	71	69.5	Passed
53)	Wayman, B. C.	SBA	PM/7542	80	56	63	Passed
63)	Walch, H. W.	SBA	H/2347	69	56	61.5	Passed

2. The marks obtained by candidates who failed have been communicated to the Commanding Officer of the ship or establishment in which the rating was serving at the time of the examination.

3. Papers from overseas vessels have, in some cases, not yet been received. If any examination papers should be forthcoming later, the results thereof will be published as soon as practicable.

4. The 29th May, 1945, is to be regarded as the basic date for the passing of this examination.

5. The original copies of Forms A.S. 1236 and A.S. 1237 (iv) have been completed and forwarded to the ships and establishments concerned. Duplicate copies have been forwarded to the Naval Officer in Charge, Flinders Naval Depot. The necessary notation should be made on the Service Certificates of candidates.

(This Order will be reprinted for posting on Notice Boards.)

(465/201/952)

378.

READY USE LOCKERS, PATTERN 7152—MODIFICATION FOR STOWAGE OF BOXED BOFORS AMMUNITION.

Modifications to Pattern 7152 R.U. Lockers (F.A.M.) to permit their use in lieu of R.U. Lockers Pattern 7105 (Oerlikon Magazine Locker) are shown in the appended diagram.

2. From a comparison of weight and stowage it will be seen that a considerable saving in weight will be effected by the use of one of these lockers per twin Bofors, or two single guns mounted in close proximity, instead of two Pattern 7105 R.U. lockers. Particulars of lockers are as follows:—

Pattern No.	Weight.	Stowage.
7152 ..	505 lb.	8 Boxes C.219.
7105 ..	560 lb.	4 Boxes C.219.

3. At single guns, Pattern 7105 Lockers must be fitted unless any necessary top weight compensation can be made as the Pattern 7152 R.U. Locker, when full, is 605 lb. heavier than the Pattern 7105 R.U. Locker.

(421/203/96.)

379.

A.M.S. VESSELS—MAGAZINE BATTENS—REPORTS.

Reports in accordance with Navy Order 66 of 1945 are no longer required.

(603/267/1631.)

380.

NAVAL CENSORSHIP.

Navy Order 23 of 1944—"Naval Censorship"—is amended—

(a) by omitting from paragraph 14, as amended by Navy Order 177 of 1944, the words "South of 20° S.,"; and

(b) by omitting from paragraph 16, as amended by Navy Order 215 of 1945, the words "South of 14° S.," and inserting in lieu thereof the words "in Australia."

(563/201/2104.)

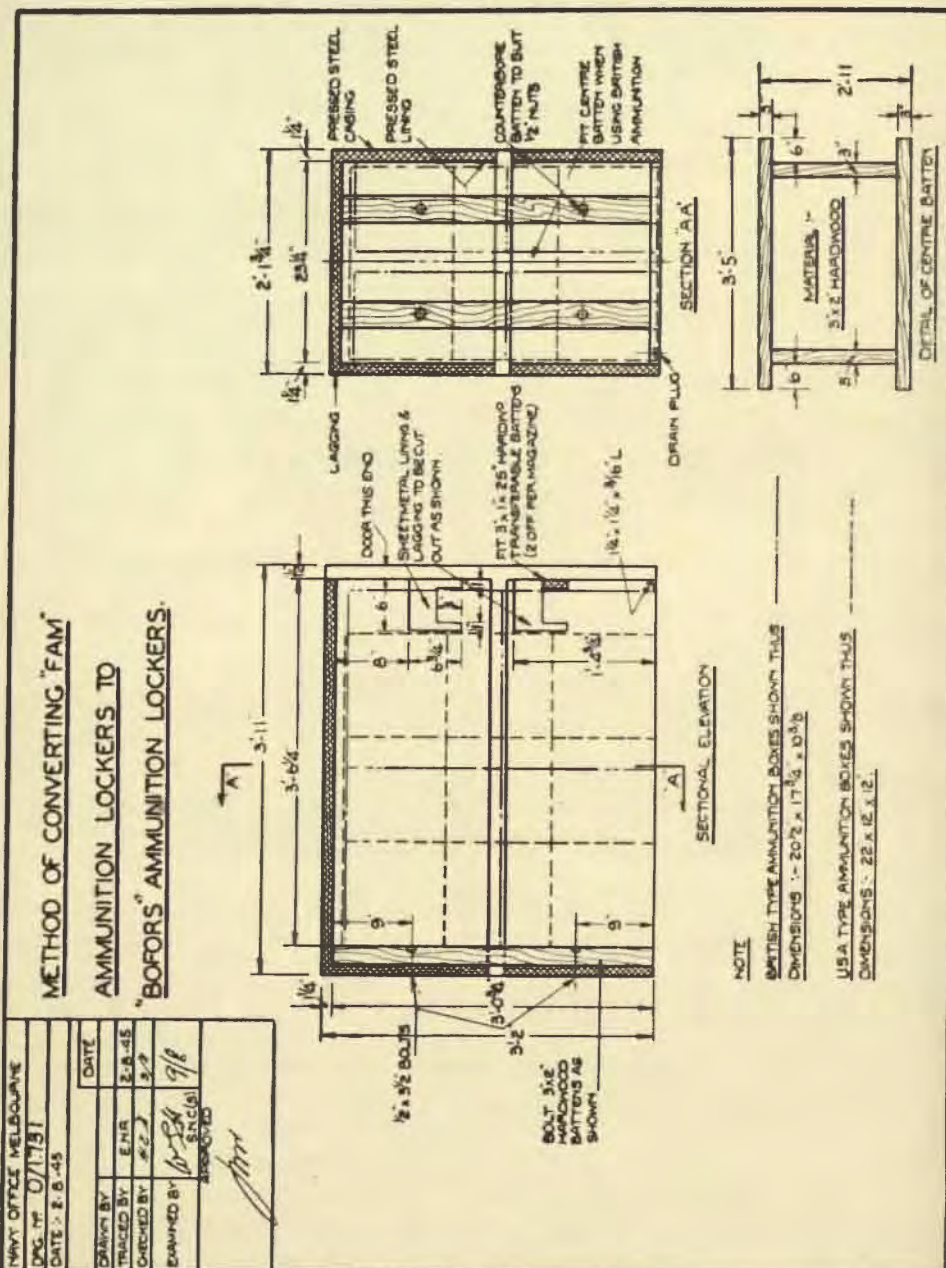

381.

INTERNAL COMBUSTION ENGINES—STARTING GEAR— PRECAUTIONS.

A.F.O. 1891/45 reads as follows:—

"A fatal accident has occurred due to the starting button of an electrically-started Diesel engine being accidentally pressed and turning the engine, causing the barring lever to strike a rating who was working on the engine.

2. A shroud constructed either of metal or wood is to be fitted round the push button to prevent accidental operation. Where not already fitted this work is to be treated as a defect.

3. Separate action will be taken for new construction ships and craft.

4. In the case of air-started internal combustion engines, care should be taken to ensure that the air master valve is shut when personnel are working on the engine."

2. Immediate action is to be taken by base and ships' staffs to fit the necessary shroud.

(524/202/2620.)

382.

TELESCOPES GUN-SIGHTING PATTS. G.A.100 AND G.A.100* —ISSUE OF, INSTEAD OF OTHER PATTERNS.

The above-mentioned telescopes may be issued in lieu of the following patterns which are in short supply:—

G.353, G.353A, G.353AH, and G.354.

2. To enable telescopes patts. G.A.100 and G.A.100* to be fitted in 3.5-in. telescope holders an adapter will be issued to ships concerned. This adapter will be supplied as:—

Telescopes Patts. G.A.100 and G.A.100*:—

Adapters for fitting to 3.5-in. telescope holders.

(490/215/343.)

383.

DEPENDANT ALLOWANCE FOR CHILDREN OVER SIXTEEN YEARS RECEIVING FULL-TIME EDUCATION.

As a War Measure, authority has been given for payment of Dependant Allowance as from the 11th July, 1945, in cases where the son, daughter, stepson, stepdaughter, legally adopted child, or any other child dependent on the member, e.g., his brother or sister, over sixteen and under eighteen years of age, is receiving full-time education at a school or university.

2. In the case of brothers and sisters, payment will be subject to a means test. In other cases, no means test is required.

3. Application for payment of this allowance should be made on Forms A.S.1299z or A.S.1299y as appropriate, and forwarded to Navy Office for consideration of the Naval Board, together with a statement showing name and address of school or university at which child is attending, and the period during which such attendance will be continued.

4. Amendment to Naval Financial Regulations and Instructions will be promulgated in due course.

(407/203/5752.)

384.

CASH ADVANCES IN AMERICAN CURRENCY FROM BRITISH PACIFIC FLEET UNITS TO R.A.N. ACCOUNTING AUTHORITIES—RATE OF EXCHANGE.

Cash advances made in American currency by British Pacific Fleet Units to R.A.N. Ships are converted from American to Sterling currency at the exchange rate of 4·035 dollars to £1 Sterling.

2. The Sterling amount thus arrived at is then converted to Australian currency at the exchange rate of £100 Sterling equals £125 Australian; the amount in Australian being transferred to the relevant parent ship.

3. On reconversion of the American currency to Australian, the exchange rate is—

3·228 dollars = £1 Australian.

4. Example:—

£100 Sterling = 403·50 dollars.

£100 Sterling = £125 (A.).

£125 (A.) at 3·228 to £1 (A.) = 403·50 dollars.

(418/201/347.)

385.

LODGING ALLOWANCE.

With reference to Naval Financial Regulations and Instructions, Article 64, it is notified that, operative from 1st June, 1945, lodging allowance is increased from 1s. 6d. per diem to 2s. per diem for leading rates and below, who are unable to live at home and in respect of whom marriage or dependant allowance is being paid.

2. The necessary amendment to Naval Financial Regulations and Instructions will be effected.

(407/201/1292.)

386.

**KIT BAGS, HAMMOCKS, ETC.—LOSSES DURING TRANSPORT—
LABELLING AND MARKING.**

With reference to paragraph 6 of Navy Order 264 of 1945, it has been reported that, at certain centres, Military Forwarding Officers have refused or are reluctant to accept, for consignment by rail, unaccompanied baggage of Naval personnel in cases where the total weight of the packages belonging to an individual member exceeds 112 lb., as provided in Military Regulations for Army personnel.

2. The Department of the Army has been contacted in the matter, it being pointed out that, in many instances, e.g., officers, artificer and artisan ratings, Naval personnel are required to be in possession of, and to transport from ship to ship, baggage of a total weight much in excess of the maximum allowed for Army personnel. As a result of the representations made, advice has been received that instructions are in course of issue to Military Forwarding Officers which will provide for the acceptance for consignment of all baggage of Naval personnel, irrespective of weight, handed in by a competent Naval Authority.

3. Steps are however to be taken by responsible officers at despatching naval establishments to ensure that authorized Service effects only are delivered to Military Forwarding Officers for consignment at Government expense, and that these items are packed, where possible, in the normal Service containers, i.e., kit bags, hammocks, tool chests, suit-cases or trunks.

4. It is also notified that a Military Forwarding Officer is located at Townsville and can be contacted at the following address, viz.:—

Railway Goods Yards, Townsville.

This addition is to be made to the list of Military Forwarding Officers shown in paragraph 7 of Navy Order 264 of 1945.

(516/201/552.)

387.

EMPTY AMMUNITION PACKAGES—RETURN OF.

It is essential that empty ammunition packages are returned to Australia from forward areas as soon as possible after firings in H.M.A. Ships or after emptying when ammunition is issued to Ships with bottlerack stowage. The types of package particularly required at the earliest possible date at the factories for re-filling are those containing ammunition used for bombardment and long-range A.A. firing, and these should be given priority in transport. These packages comprise—

Cases, magazine for 8-in. and 6-in. cordite.

Ammunition boxes for 4-in. fixed ammunition.

Cartridge and Shell boxes for 4·7 in.

2. Whilst there is less urgency, every opportunity should be taken to return 2 pdr. packages, but packages for Bofors, Oerlikon and other S.A.A. should only be returned if space is available without detriment to packages of higher priority.

3. Naval Officers-in-Charge in forward areas and the Commanding Officers of Armament Store Issuing Ships should see that every opportunity of freight to the mainland for "Empties" is utilized. Armament Store, Naval Store and Victualling Store Issuing Ships and Carriers and other Auxiliary vessels are to load these stores whenever space is available. Consigning officers should supply the freightship with a bill of lading stating approximate quantities and measurements of the cargo, and when practicable with issue vouchers to be handed to the consignee. A certificate that the packages are empty is also to be handed to the Commanding Officer or Master.

4. Empty packages should be consigned to the Naval Armament Supply Officer, Brisbane; Superintending Armament Supply Officer, Sydney; or Naval Armament Supply Officer, Maribyrnong, according to the destination of the freightship. Brief particulars should be signalled to the consignee when shipment is effected.

5. Empty fired cartridge cases are to be dealt with in a similar manner, priority being given to the return of 4.7 in. and 4 in.

(421/202/853.)

388.

FOURTH VICTORY LOAN.

The Government desires to emphasize that the success of the forthcoming Fourth Victory Loan is most important and that subscriptions should be made voluntarily by all sections of the community.

2. Approximately 750,000 of Australia's population are in the fighting services, and it is desired that every opportunity should be given to them to invest their savings in what is regarded as the best and safest investment in the Commonwealth.

3. Such money invested in War Loans not only bears the highest rate of interest now available, but also helps the finances of the country. Bonds and War Savings Certificates are always readily negotiable, and provide a valuable addition to deferred pay and other savings which may be required to assist in re-establishment in civil life after the war.

4. Bonds in the Fourth Victory Loan may be purchased outright for cash or by instalments. Care must be taken to ensure that each subscriber makes application for bonds on the appropriate form and indicates therein his wishes in regard to the disposal of the bonds. In addition, Service personnel may make allotments of pay at any time as continuous subscriptions for the purchase of bonds in Commonwealth loans—

(a) *Outright Purchase.*—Cash subscriptions for outright purchase of Bonds should be lodged with the Supply Officer, who will issue an official receipt for each amount received. Amounts should be taken on charge in the Cash Account, and credited to "Trust Fund—Other Trust Moneys." A voucher charged to "Trust Fund—Other Trust Moneys" should then be prepared in favour of the Registrar of Inscribed Stock at the capital city branch of the Commonwealth Bank in the State in which the bond application

will be lodged, and forwarded under cover of Form N.A.5 to the Certifying Officer of the capital city in that State, for payment.

(b) *Instalment System.*—Approval is given for the use of the allotment system where purchase by instalments is desired. Such allotments are to be declared on Form A.S.63, at a monthly rate, at not less than 10 per cent. of the face value of the bond, in favour of the Registrar of Inscribed Stock at the capital city branch of the Commonwealth Bank in the State in which the bond application will be lodged. The bond application, in such cases, should bear a notation that a monthly allotment has been declared. Payment of these allotments ceases when the full amount applied for has been reached.

(c) *Service Allotments for Continuous Subscription to Commonwealth Loans.*—Allotments for this purpose shall be declared at fortnightly rates of not less than 5s. in favour of the Commonwealth Bank in the capital city of the State in which purchase of the bonds is desired. Forms A.S.63 should clearly indicate that the allotment is for continuous subscription to Commonwealth Loans. Simultaneously with the declaration of the allotment a form of application (*pro forma* appended) must be completed by the applicant and forwarded, attached to Form A.S.63, to the Director of Navy Accounts, Navy Office. These allotments will be paid by the Bank, to a special account in the member's name, on which interest will be allowed at the rate borne by the Bond selected for purchase by the member. As the sum of £10 accumulates in the account, the Bank will purchase a £10 Commonwealth Treasury Bond and place it in safe custody for the applicant.

Allotments should clearly understand that these allotments will continue to be paid until stoppage advice is received, or where, for Service reasons stoppage is necessary. In either event, the balance of the amount subscribed which has not been invested may be credited to the member's bank account or paid to him whichever he desires.

Where ships in which a Supply Officer is not borne are absent from base, amounts may be paid to the Supply Officer of any H.M.A. Ship or Naval Depot.

All completed bond application forms, whether for cash purchase or for purchase by instalments, should be sent direct to the Registrar of Inscribed Stock in the particular State, with an intimation that a cheque covering the cash payments will be forwarded from the Sub-Treasury.

5. The Fourth Victory Loan will open on September 25th, 1945.

(552/202/6.)

(This Order will be reprinted for posting on Notice Boards.)

ALLOTMENT.

No. Rank

Name in full
(In block letters)Address
(Unit, &c.)

Civilian Address

To Commonwealth Bank of Australia.

I have authorized the Department of the Navy to allot the sum of shillings per day from my pay, and to forward such allotments to you for purchase of ^{short term}long term Commonwealth Treasury Bonds on my behalf from time to time as sufficient funds accrue to purchase a £10 bond.

Please hold the Bonds for safe custody and credit interest to my account with.....
(Bank)

.....
(Branch) (No. of Savings Bank A/c.)

* Please hold the Bonds for safe custody, open a Savings Bank Account in my name and credit interest thereto.

Date
(Signature)

(* To be completed by members who have no Bank Accounts.)

Specimen Signature of Applicant. }

No. }

389.

CORRIGENDA.

(a) With reference to Navy Order 601 of 1944, the heading referring to Form S.102 is to be amended to read "Form S.101, Size 2.

(b) With reference to Navy Order 337 of 1945—"Signals—Indications of Precedence and Their Use"—paragraph 3 is to be amended to read "Navy Orders 160 and 233 of 1945 are hereby cancelled.

By Authority: H. E. DAW, Government Printer, Melbourne.

RESTRICTED.(FOR OFFICIAL USE ONLY.)

Commonwealth Navy Orders.

Navy Office, Melbourne,
11th September, 1945.

The following Orders, having been approved, are hereby promulgated for information and guidance, and necessary action.

By direction of the Naval Board,

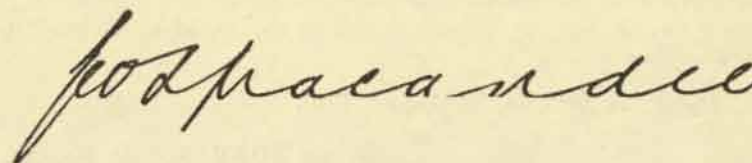

Secretary.

*The Commodore Commanding H.M.A. Squadron,
and Commanding Officers of H.M.A. Ships,
Officers in Charge of H.M.A. Naval
Establishments, and others concerned.*

TABLE OF CONTENTS.

No.	Subject.
390.	Delegations of Minister's Powers under National Security Regulations.
391.	Address of Correspondence for the Commodore Commanding H.M.A. Squadron.
392.	Port Directors.
393.	Tool Kits for Radio Mechanics (R), (W), (S), and (C).
394.	Crests of H.M.A. Ships—Supply to British Centre, Hyde Park.
395.	Table Fans for Sick Bays of H.M.A. "Tribal" Class Destroyers and H.M.A. Frigates Carrying Medical Officers.
396.	Prevention of Fire in Naval Storehouses.
397.	B.R. 810/1943 (Late O.U. 5409)—Rate Book for Naval Stores.
398.	Primers D.C. Mk. VII., Lot 532 of H. and H. manufacture—Withdrawal and Disposal.
399.	Corrigendum.

390.

DELEGATIONS OF MINISTER'S POWERS UNDER NATIONAL SECURITY REGULATIONS.

The following delegations of powers under National Security Regulations are hereby promulgated for information:—

(a) (*Commonwealth Gazette No. 165, dated 28th August, 1945.*)

Commonwealth of Australia.

NATIONAL SECURITY (GENERAL) REGULATIONS.

DELEGATIONS OF POWERS AND FUNCTIONS BY MINISTER FOR THE NAVY.

In pursuance of section 17 of the *National Security Act 1939-1943*, I, NORMAN JOHN OSWALD MAKIN, Minister of State for the Navy, do hereby delegate to every officer who, at any time during the continuance of this delegation, holds the office or performs the duties of the office of Chief of Naval Staff the powers and functions conferred upon the Minister of State for the Navy by regulation 45D of the National Security (General) Regulations.

Dated this 20th day of August, 1945.

(Signed) NORMAN J. O. MAKIN,
Minister of State for the Navy.

(b) (*Commonwealth Gazette No. 165, dated 28th August, 1945.*)

Commonwealth of Australia.

NATIONAL SECURITY (GENERAL) REGULATIONS.

DELEGATION OF POWERS AND FUNCTIONS BY MINISTER.

In pursuance of section 17 of the *National Security Act 1939-43*, I, NORMAN JOHN OSWALD MAKIN, Minister of State for the Navy, acting for and on behalf of the Minister of State for the Army, do hereby delegate to every officer who, at any time during the continuance of this delegation, holds the office or performs the duties of the office of Chief of Naval Staff, the powers and functions conferred upon the Minister of State for the Army by regulations 54 and 55, respectively, of the National Security (General) Regulations with respect to the possession of land and the use of land, for naval purposes.

Dated this 20th day of August, 1945.

(Signed) NORMAN J. O. MAKIN,
for and on behalf of the
Minister of State for the Army.

(c) (*Commonwealth Gazette No. 165, dated 28th August, 1945.*)

Commonwealth of Australia.

NATIONAL SECURITY (GENERAL) REGULATIONS.

DELEGATION OF POWERS AND FUNCTIONS BY MINISTER.

In pursuance of section 17 of the *National Security Act 1939-43*, I, NORMAN JOHN OSWALD MAKIN, Minister of State for the Navy, acting for and on behalf of the Minister of State for Defence, do hereby delegate to every officer who, at any time during the continuance of this delegation, holds the office or performs the duties of the office of Chief of Naval Staff the powers and functions conferred upon the Minister of State for Defence by regulations, 4 (in respect of areas under the control of the Naval Board), 24 (in respect of shipping only), 45, 45B (in respect of shipping only), 46, and 47, respectively, of the National Security (General) Regulations, in so far as the exercise of those powers and functions is necessary for Naval purposes.

Dated this 20th day of August, 1945.

(Signed) NORMAN J. O. MAKIN,
For and on behalf of
the Minister of State for Defence.

(d) (*Commonwealth Gazette No. 165, dated 28th August, 1945.*)

Commonwealth of Australia.

NATIONAL SECURITY (GENERAL) REGULATIONS.

DELEGATION OF POWERS AND FUNCTIONS BY MINISTER FOR THE NAVY.

In pursuance of section 17 of the *National Security Act 1939-43*, I, NORMAN JOHN OSWALD MAKIN, Minister of State for the Navy, do hereby delegate to every officer who, at any time during the continuance of this delegation, holds the office of Chief of Naval Staff or of Naval Officer-in-Charge at any Port or performs the duties of any of those offices the powers and functions conferred upon the Minister of State for the Navy by regulation 64 of the National Security (General) Regulations.

Dated this 20th day of August, 1945.

(Signed) NORMAN J. O. MAKIN,
Minister of State for the Navy.

391.

**ADDRESS OF CORRESPONDENCE FOR THE COMMODORE
COMMANDING H.M.A. SQUADRON.**

Delays have occurred in the delivery of correspondence addressed to the Commodore Commanding H.M.A. Squadron, c/o the ship in which the broad pennant is flying.

2. Correspondence, therefore, is to be addressed :—

THE COMMODORE COMMANDING

H.M.A. SQUADRON,

c/o G.P.O.

the name of the ship in which the pennant is flown being omitted.

3. Navy Order 169 of 1941 is cancelled.

(563/201/2206.)

392.

PORT DIRECTORS.

With reference to Navy Order 425 of 1944, a Royal Australian Navy Port Director was appointed at Balikpapan on 25th August, 1945.

(1937/2/315.)

393.

TOOL KITS FOR RADIO MECHANICS (R), (W), (S), AND (C).

With reference to A.F.O's.5080/41, 2793/42 and 4355/44, approval has been given to the provision of modified sets of tool kits for use of Radio Mechanics (R), (W), (S) and (C). A list of the items comprising the kit is contained in paragraph 5 below.

2. The tool kits are to be issued to Radio Mechanics (R), (W), (S), and (C) on completion of their qualifying course and such issues noted on their Service Certificates. Ratings, who have already qualified and have not been issued with their tool kits, are to apply for them through their Commanding Officer. Radio Mechanics (R), (W), and (S) who have been supplied with a kit of tools on qualifying are not to be issued with a further set on qualifying as Radio Mechanic (C).

3. The kits will be issued outright to Permanent Naval Force ratings and become the personal property of the individuals, who will be responsible for maintaining them up to full scale. Replacement of tools lost, broken or worn out may be made from Service sources, on repayment, providing the Commanding Officer is satisfied that the circumstances are such that replacements cannot be obtained from commercial sources.

4. Issues to "hostilities only" ratings will be a personal issue, but will remain the property of the Crown. Articles lost, broken or worn out will be replaced from the naval store, subject to the value of any tools lost, or damaged by misconduct or neglect, being recovered in accordance with K.R. and A.I., Article 1936.

5. The kit of tools referred to is as follows :—

Sub head.	Patt. No.	Description.	Qty.
		<i>Permanent.</i>	
B. 10	3121	Boxes, tool, steel, engineer's	1 No.
B. 11	648	Drills, hand	1 Pair
	2349	Snips, tinsmiths, 8" straight	1 No.
		Tape, steel, 6'	1 "
		Rule, steel, 6" marked in inches and centimetres	1 Pair
E. 10		Scissors	1 No.
E. 12		Mirror (similar to dental mirror)	1 No.
		<i>Consumable.</i>	
B. 10	83	Locks, brass, pad, 1 1/2"	1 No.
B. 11		Twist drills, H.S.P.S., sizes 3/32", 1/8", 5/32", 3/16", 7/32", 1/4", and Nos. 6 to 16, 26, 34, 44	2 No. of each
	848	Files round, taper, bas, 8"	1 No.
	78	" hand, bas, 1 safe edge, 6"	1 "
		" 1/2" round, 2nd cut, 8" long	1 "
		" hand, smooth, 1 safe edge, 6"	1 "
	813	File cleaners	1 "
	480	Hammer, B.P., 8-oz., w/handle	1 "
	1199	Pliers, insulated, side cutting, 7"	1 Pair
	1850	" roundnose, 6"	1 "
	1843	" longnose, half round, 7"	1 "
		" angle, cutting, 6"	1 "
	1905	Punches, nail or pin, 1/8" centre, 4"	1 "
		" centre, 4"	1 "
	2252	Screwdriver, cabinet, 8"	1 "
	2301	" instrument makers, 3"	1 "
	2300	" instrument makers, 3" x 3/16"	1 Set
		" 3/64", 1/16", 5/64", 3/32"	1 No.
	2248	" radio, 3" x 1/8"	1 "
		" insulated, 6"	1 "
		Spanners, B.A., double-ended set of 5 (0 x 2, 1 x 3, 4 x 6, 5 x 7, 8 x 9)	1 Set
	3013	Spanner, adjustable, angle head (Crescent), 8"	1 No.
		Pliers, multigrip	1 Pair
	1075	Gauges, feeler, No. 1 (2-18 mils)	1 No.
		Spanners, B.A., box, tubular, 6" long, D.E., 0 x 2, 4 x 6, B.A.	1 Set
		Tweezers, watchmakers	1 Pair
		Contact file	2 No.
	1529	Knife, shoemaker	1 "
	2173	Hacksaw, 10" frame blades, 10" (32 teeth)	1 Doz.
	381	Chisel, cold (5/8")	1 No.
	3964	Taps, 2 B.A. taper, 2 B.A. second, 2 B.A. plug	1 No. of each
	3966	" 4 B.A. taper, 4 B.A. second, 4 B.A. plug	1 "
	3968	" 6 B.A. taper, 6 B.A. second, 6 B.A. plug	1 "
	3945	Wrench, adjustable for taps (T. type, to 1/4")	1 "
		Gimlet, 3/16"	1 "
		Spanners, set, 1/4", B.S.F.	2 "
E. 11	C. 290	Brushes, varnish, 1/2"	1 "
	C. 281	" sash tool, No. 6	1 "
E. 12	783	Handles for files	2 "
F. 2		Torch	1 "
		Soldering iron, 210 v.lt, 75W-85W	1 "

6. Navy Order 23 of 1945 is cancelled.

(2037/8/96.)

394.

CRESTS OF H.M.A. SHIPS—SUPPLY TO BRITISH CENTRE, HYDE PARK.

The British Centre, Hyde Park, Sydney, which is available for personnel of the Royal Australian Navy, has requested to be supplied with a replica of the Crests of H.M.A. Ships.

2. Ships are, if possible, to comply with the request.

(416/201/1100.)

395.

TABLE FANS FOR SICK BAYS OF H.M.A. "TRIBAL" CLASS DESTROYERS AND H.M.A. FRIGATES CARRYING MEDICAL OFFICERS.

Approval has been given to the addition to the List of Special Allowances of Naval Stores of 2 No. electric table fans, for use in the sick bay of the undermentioned H.M.A. Ships :—

" Tribal " Class Destroyers,

Frigates (in which a Medical Officer is borne).

(603/247/1915.)

396.

PREVENTION OF FIRE IN NAVAL STOREHOUSES.

Investigation consequent on a fire which occurred recently in a Base Naval Store revealed the fact that smoking was permitted in a section of a store room.

2. The attention of all concerned is drawn to the necessity for the strict prohibition of smoking in all Naval store buildings and in the vicinity of storerooms in which inflammable stores are stowed.

3. Organic fibrous material such as used cotton waste, old cordage, coir fenders, etc., stored in a wet or damp state, is liable to spontaneous combustion and every care is to be exercised to prevent damage from this cause.

(569/231/50.)

397.

B.R. 810/1943 (LATE O.U. 5409)—RATE BOOK FOR NAVAL STORES.

On receipt of B.R. 810/1943, the latest edition of " Rate Book for Naval Stores ", all copies of the previous edition (O.U. 5409), together with relevant errata, should be returned to the Superintending Naval Store Officer, Sydney, for reissue.

2. Copies which can now be spared should be sent to the Superintending Naval Store Officer, Sydney, immediately.

(A.F.O. 4189/1944.)
(571/202/2174.)

398.

PRIMERS D.C. MK. VII., LOT 532 OF H. AND H. MANUFACTURE—WITHDRAWAL AND DISPOSAL.

All primers D.C. Mk. VII., Lot 532 of H. and H. 9/42 manufacture, are to be landed and others drawn in lieu.

2. Stocks at naval armament depots and landed by H.M.A. Ships are to be disposed of by dumping.

3. Navy Order 654 of 1944 is to be amended accordingly.

(471/205/2394.)

399.

CORRIGENDUM.

With reference to Navy Order 359 of 1945, sub-paragraph 1 (a) is to be amended to read :—

" (a) Lists of naval stores on permanent loan (See B.R. 4, Article 50)."

RESTRICTED.

(FOR OFFICIAL USE ONLY.)

Commonwealth Navy Order.

Navy Office, Melbourne,
11th September, 1945.

The following Order, having been approved, is hereby promulgated for information and guidance and necessary action.

By direction of the Naval Board,

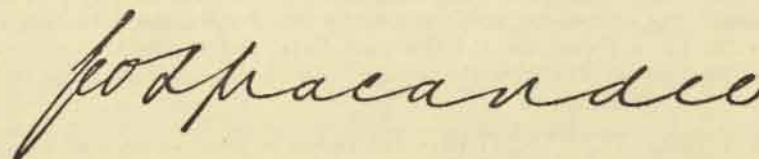

Secretary.

*The Commodore Commanding H.M.A. Squadron,
and Commanding Officers of H.M.A. Ships,
Officers in Charge of H.M.A. Naval
Establishments, and others concerned.*

TABLE OF CONTENTS.

No.	Subject.
400.	Honours and Awards—The 1939-45 Star, the Africa Star, the Atlantic Star, the Air Crew Europe Star, the Italy Star, the France and Germany Star, the Pacific Star, the Burma Star, and the Defence Medal.

HONOURS AND AWARDS—THE 1939-45 STAR, THE AFRICA STAR, THE ATLANTIC STAR, THE AIR CREW EUROPE STAR, THE ITALY STAR, THE FRANCE AND GERMANY STAR, THE PACIFIC STAR, THE BURMA STAR, AND THE DEFENCE MEDAL.

Qualifications and instructions for the issue of ribbon and emblems.

SECTION I.

The King has been pleased to alter the conditions of the 1939-43 Star (renaming it the 1939-45 Star) and of the Africa Star, and to withdraw the decision promulgated in paragraph 1 and paragraph 3 (e) of A.F.O. 3658/43 that "no individual will qualify for both the Africa and 1939-43 Stars". His Majesty has also been pleased to approve the institution of further campaign stars, viz: the Atlantic Star, the Air Crew Europe Star, the Italy Star, the France and Germany Star, the Pacific Star, and the Burma Star, and of a Defence Medal.

The respective ribbons are as follows:—

THE 1939-45 STAR.—The ribbon is dark blue, red and light blue in three equal vertical stripes. The dark blue stripe is intended to mark the service of the Naval Forces and the Merchant Navy, the red stripe that of the Armies and the light blue stripe that of the Air Forces. The ribbon is to be worn with the dark blue stripe furthest from the left shoulder.

2. THE AFRICA STAR.—The ribbon is pale buff in colour with a central vertical red stripe and two other narrower stripes, one dark blue and the other light blue. The background is intended as a symbol of the desert; the central red stripe stands for the Armies, the dark blue stripe for the Naval Forces and the Merchant Navy, and the light blue stripe for the Air Forces. The ribbon is to be worn with the dark blue stripe furthest from the left shoulder.

3. THE ATLANTIC STAR.—The ribbon is blue, white, and sea green, shaded and watered, the design being intended as a symbol of service in the Atlantic. The ribbon is to be worn with the blue edge furthest from the left shoulder.

4. THE AIR CREW EUROPE STAR.—The ribbon is light blue with black edges and there is, in addition, a narrow yellow stripe on either side. The design is symbolic of the continuous service of the Air Forces by night and day.

5. THE ITALY STAR.—The ribbon is in the Italian colours—green, white, and red. There are five vertical stripes of equal width, one in red at either edge, and one in green at the centre, the two intervening stripes being in white.

6. THE FRANCE AND GERMANY STAR.—The ribbon is in the red, white and blue of the Union Flag and these colours are also used as a symbol of France and the Netherlands. There are five vertical stripes of equal width, one in blue at either edge and one in red at the centre, the two intervening stripes being in white.

7. THE PACIFIC STAR.—The ribbon is dark green with red edges and with a central yellow stripe. There are also two other narrow stripes, one dark blue and the other light blue. The green and yellow stand for

the forests and the beaches of the Pacific, the red edges for the Armies, the dark blue stripe for the Naval Forces and the Merchant Navies, and the light blue stripe for the Air Forces. The ribbon is to be worn with the dark blue stripe furthest from the left shoulder.

8. THE BURMA STAR.—The ribbon is dark blue with a central red stripe and, in addition, two orange stripes. The red stands for the British Commonwealth Forces and the orange for the sun, and these are placed on a contrasting background of dark blue.

9. THE DEFENCE MEDAL.—The centre of the ribbon is flame coloured, and the edges are green, symbols of the enemy attacks on our green and pleasant land. Two black stripes represent the black-out.

SECTION II.

In the Navy, the following classes are eligible for the Stars and the Defence Medal:—

- (a) All officers and men of the Royal Australian Navy and its Reserves.
- (b) Officers and men of the Merchant Navy under T. 124 and like agreements in His Majesty's ships of war.
- (c) Officers and ratings of the Women's Royal Australian Naval Service.
- (d) Members of the Nursing Services.
- (e) Canteen Staffs.
- (f) Civilians with protective commissions serving in His Majesty's ships.

2. No one will be held to have qualified for the Atlantic Star, the Air Crew Europe Star, the Italy Star, the France and Germany Star, the Pacific Star or the Burma Star until he has qualified for the 1939-45 Star (except as laid down in paragraphs 6 and 7 of this section).

3. Officers and ratings who have qualified for the 1939-45 Star through time spent as prisoners of war, as set forth in paragraph 2 (g) of Section III. below must serve such time afloat, or on shore in an operational area, before they can be held to begin to qualify for the Atlantic Star or the Air Crew Europe Star, or to qualify for one of the other Stars.

4. Officers and ratings who have qualified for the 1939-45 Star through service on shore in areas of Army Operational Commands as set forth in paragraph 2, E (b) of Section III. below or have qualified for it by reason of the award of a decoration or Mention in Despatches, or have qualified for it under Navy Order 466 of 1943, paragraph 5, must have served six months afloat, or on shore in an operational area, or two months in the case of air crews, before they can begin to qualify for the Atlantic Star or the Air Crew Europe Star, or qualify for one of the other Stars, or, if they happen to have so served for some period less than six or two months, they must serve six or two months less such period already served.

5. Officers and ratings who lose their lives on service that would be a qualification for any of the Stars, or as a result of sickness attributable to such service, or whose qualifying service is brought to an end by a disability due to service will be held to qualify for the Star, irrespective of whether

they have completed the prior operational service normally required to be completed before they are held to qualify. In the case of death, the ribbon will not be issued, but the Star, when manufactured, will be sent to the next of kin.

6. Officers and ratings who receive the award of a decoration or a Mention in Despatches while on service that would qualify for any of the Stars will be granted the Star forthwith, irrespective of whether they have completed the prior operational service normally required to be completed before they are held to be qualified.

7. Any officer or rating who began his service afloat less than six (or in the case of air crews, two) months before the 8th May, 1945, the date when active hostilities in Europe ended, if on service qualifying for the Italy Star or the France and Germany Star, (or before 15th August, 1945, if on service qualifying for the Pacific or Burma Star) will be awarded the Star in question, though he has not done the prior six or two months' service normally required. Similarly, if on service qualifying for the Atlantic Star, he will be awarded that Star though he has not completed six or two months' service nor done the prior six or two months' service normally required.

8. Any officer or rating who has transferred to the Royal Australian Navy from one of the other Services may count qualifying service for the 1939-45 Star while in the Army or Air Force towards the service required to qualify.

9. Naval personnel appointed or drafted in a non-operational area ashore for staff duties in connexion with the operations that qualify for the Italy Star, the France and Germany Star, the Burma Star or the Pacific Star can qualify for the Star in question by 30 or more days' service on duty in the area qualifying for the Star, provided that they are already qualified for the 1939-45 Star.

10. A candidate who qualifies for the Atlantic Star, the France and Germany Star and the Air Crew Europe Star or two of these will be awarded only the Star first earned. A clasp will be awarded with it denoting that the service which would have qualified for the second Star earned has been rendered. A silver rose emblem will be worn to denote the award of the France and Germany, Atlantic or Air Crew Europe clasp as the case may be.

11. R.A.A.F. PERSONNEL.—(a) The ribbon and emblem of any of the awards dealt with in this Order may be issued to the R.A.A.F. ranks on loan to the Royal Australian Navy who are qualified under Naval regulations.

(b) Records of those to whom the ribbon and emblems are issued should be kept on the form prescribed in Section IV. of this Order. On completion, one copy of this form is to be sent to the Secretary, Naval Board.

SECTION III.

1. (A) Service qualifying for the respective awards is as shown below in paragraphs 2-10. The expression "Service afloat" means service while borne for pay on the books of:—

- (a) A ship of war in seagoing commission. (Service while refitting may count as "Service afloat" provided that the ship remains in commission.)
- (b) A parent ship for service in commissioned tenders which are wholly or mainly employed on sea-going duties,

(c) A commissioned ship for such other seagoing service as the Naval Board may declare to qualify for this purpose. In this category will be included:—

- (i) Service while embarked for duty in merchant ships (e.g., D.E.M.S. personnel, Commodores of Convoy and their staffs, Naval personnel in hospital ships, etc.).
- (ii) Service in seagoing boom defence and examination vessels.
- (iii) Service afloat in combined operations craft as laid down in paragraph 2 (K) of this Section.

(B) The following shall not be regarded as service afloat:—

- (a) Service in stationary depot ships which only went to sea when proceeding from port to port (e.g., for the purpose of changing base for refit, etc.).
- (b) Service at shore bases and depots.
- (c) Service in vessels employed wholly or mainly within boom-protected waters, or when no boom existed, within the limits of smooth waters.

(C) In any case of difficulty, the Naval Board shall determine, for the purpose of the award, which vessels or classes of vessels shall be regarded as ships of war, what nature of service afloat shall be considered as sea service or harbour service, and what flying unit shall be considered operational. Applications from headquarters personnel of the Naval Air Arm for exceptional treatment may be considered if accompanied by full details of their operational service.

2. QUALIFICATIONS FOR THE 1939-45 STAR.—Six months' service afloat as defined in paragraphs (E), (F) and (G) at any time after 3rd September, 1939, up to the 15th August, 1945, the date of the end of active hostilities in the Pacific, in areas of active operations. These areas are:—

- (i) From 3rd September, 1939: The Atlantic Ocean, including Home Waters and the North Sea; the Baltic; the Arctic Ocean between Greenland and longitude 70 E., and that part of the Indian Ocean lying south of 15 S. and west of 55 E.
- (ii) From 1st June, 1940; As (i) with the addition of the Pacific Ocean and the rest of the Indian Ocean.
- (iii) From 10th June, 1940; Anywhere at sea.

(B) In the case of Naval air crews not qualified by six months' service afloat, to have flown operationally in a first line squadron, and to have completed two months' service either at an operational base, or in an aircraft carrier or C.A.M. ship or fighter catapult ship afloat, refit or leave periods not counting towards the service required.

(C) The award of an honour, decoration or Mention in Despatches for service afloat, or in air operations or in service on shore in Army operational areas.

(D) Service afloat, or in the air, or on shore in Army operational areas, either brought to an end by wounds or other disability due to service, or interrupted by a wound or other disability due to service of sufficient gravity to cause discharge to shore, or, if on shore,

to cause evacuation from the operational area. Such service brought to an end by death qualifies and, in due course, the Star will be sent to the next-of-kin of those so qualified. Preliminary issue of the ribbon to next-of-kin will not be made.

(E) With reference to A.F.O. 3658/43, paragraph 4 (b), the following lists have been approved:—

(a) Of operational commands, service in one or more of which between the dates set against each command amounting in the aggregate to six months will qualify in the Army for the 1939-45 Star:—

	<i>From.</i>	<i>To.</i>
France ..	{ 3rd September, 1939	9th May, 1940
China ..	{ 6th June, 1944	8th May, 1945
Burma ..	{ 11th December, 1941	21st February, 1942
New Guinea ..	{ 1st May, 1942	15th August, 1945
Italy ..	{ 7th March, 1942	15th August, 1945
Solomon Islands ..	{ 3rd September, 1943	8th May, 1945
North Africa, west of the Suez Canal and the Red Sea and east of the Straits of Gibraltar	{ 8th December, 1941	15th August, 1945
Abyssinia (including attacks on Moyale, Elwak and Kassala), Eritrea, the Somalilands and Kenya (excluding Tanganyika Territory and Uganda, except to troops whom the G.O.C.-in-C., East Africa, is satisfied were called forward from Uganda for operations in Lake Rudolf area)	{ 10th June, 1940 ..	27th November, 1941
Anglo-Egyptian Sudan	{ 10th June, 1940 ..	27th November, 1941
Malta ..	{ 10th June, 1940 ..	12th May, 1943

(b) Of operations in which service of any length between the dates set against each operation will qualify in the Army for the 1939-45 Star:—

	<i>From.</i>	<i>To.</i>
North-West Frontier, India	{ 3rd February, 1940	24th May, 1940
Norway ..	{ 18th June, 1941 ..	26th August, 1941
France ..	{ 28th July, 1942	18th August, 1942
Belgium ..	{ 14th April, 1940 ..	8th June, 1940
Holland ..	{ 10th May, 1940 ..	19th June, 1940
Lofoten Islands	{ 10th May, 1940 ..	19th June, 1940
Lucania ..	{ 12th May, 1940 ..	13th May, 1940
Iraq ..	{ 4th March, 1941	..
Persia ..	{ 10th February, 1941	..
Greece and Crete (service with R.A.F. only)	{ 10th April, 1941	31st May, 1941
Greece and Crete ..	{ 25th August, 1941	28th August, 1941
Syria ..	{ 7th November, 1940	31st May, 1941
Spitzbergen	{ 10th March, 1941	31st May, 1941
Hong Kong ..	{ 8th June, 1941 ..	11th July, 1941
Malaya ..	{ 25th August, 1941	3rd September, 1941
Lofoten Islands ..	{ 8th December, 1941	25th December, 1941
Vaagso ..	{ 8th December, 1941	15th February, 1942
Bruneval ..	{ 26th December, 1941	..
St. Nazaire ..	{ 27th December, 1941	..
Hardelot ..	{ 27th February, 1942	28th February, 1942
Madagascar ..	{ 27th March, 1942	28th March, 1942
Spitzbergen	{ 21st April, 1942 ..	22nd April, 1942
Boulogne-le-Touquet	{ 5th May, 1942 ..	5th November, 1942
Aleutian Islands (aircrew service only)	{ 16th May, 1942 ..	8th September, 1943
Dieppe ..	{ 3rd June, 1942
Sark ..	{ 3rd June, 1942 ..	16th August, 1943
Burma ..	{ 19th August, 1942	..
Burma (Brigadier Wingate's Force)	{ 3rd October, 1942	4th October, 1942
Sicily ..	{ 22nd February, 1942	15th May, 1942
	{ 7th February, 1943	15th July, 1943
	{ 10th July, 1943 ..	17th August, 1943

(F) Officers and ratings of the classes listed in Section II., paragraph 1, will qualify for the 1939-45 Star under Army rules if they served ashore, having been appointed or drafted for such service between the appropriate dates in the areas and operations listed above.

Officers or ratings passing through one of these areas on a visit or tour of inspection or for the purchase of materials, etc., in it are not thereby qualified, but if the visit or tour exceeded 30 days the case may be submitted for special consideration.

Officers and ratings who took part afloat in the operations listed in paragraph (E) (b) will not qualify under Army rules but will count this service, with other service afloat, towards the six months' qualifying period.

(G) Time spent as a prisoner of war captured during service defined in paragraphs (A), (B), or (E) (a) of Section III., will count towards the qualifying period unless there is doubt as to freedom from blame.

(H) Time spent on passage through dangerous waters in one of H.M. or H.M.A. ships or a merchant ship, or by air, to a sea appointment or to an Army operational command as defined in paragraph (E) (a) of Section III. will count towards the qualifying period for the 1939-45 Star, provided that the journey was completed. The journey will count only if the date of arrival falls within the dates set out in paragraph (E) (a) against each operation. It will then count from the date of embarkation.

Those who did not complete the journey owing to death or wounds, or injury resulting from enemy action, will qualify under paragraph 2 (D) of this section.

Passage through dangerous waters to non-operational commands will not count towards the qualifying period.

(I) The 1939-45 Star may be given specially to selected senior officers such as Commanders-in-Chief or Flag Officers Commanding important independent operational commands who do not qualify under the approved rules.

(J) CLASP TO THE 1939-45 STAR.—A clasp to the 1939-45 Star to be denoted by a silver gilt rose emblem worn on the ribbon has been instituted to mark service in the Battle of Britain. The qualification is service as air crew of fighter aircraft in the Battle of Britain between 1st July and 31st October, 1940.

(K) COMBINED OPERATIONS PERSONNEL.—The following are the conditions of award of the 1939-45 Star for service as Combined Operations Personnel:—

(a) Naval Beach Commandos and Signal Parties qualify only by service ashore in operations which qualify the Army or by six months' service in an Army operational command.

(b) Regular Crews of Combined Operations Craft, viz.:—seagoing commissioned major landing craft crews and the personnel of seagoing minor landing craft flotillas and landing barge flotillas, provided they have been to sea in their craft and have completed six months' service as such.

3. QUALIFICATIONS FOR THE AFRICA STAR.—(A) Service afloat in the Mediterranean east of the Straits of Gibraltar at any time between 10th June, 1940, and the 12th May, 1943. (Service in Gibraltar or in ships based on Gibraltar, unless they served in the Mediterranean, will not be a qualification.)

(B) Service on shore or in harbour, if appointed or drafted for such service in—

	<i>From—</i>	<i>To—</i>
(i) North Africa, west of the Suez Canal and the Red Sea and east of the Straits of Gibraltar	10th June, 1940	12th May, 1943
(ii) Abyssinia (including attacks on Moyale, Elwak and Kassala), Eritrea, the Somalilands and Kenya (excluding Tanganyika Territory and Uganda, except to troops whom the G.O.C.-in-C., East Africa, is satisfied were called forward from Uganda for operations in Lake Rudolf area)	10th June, 1940	27th November, 1941
(iii) Anglo-Egyptian Sudan	10th June, 1940	27th November, 1941
(iv) Malta	10th June, 1940	12th May, 1943

(C) The King has also been pleased to approve that the clasp approved to the 1939-43 Star referred to in A.F.O. 3658/43, paragraph 5, and denoted by the silver rose emblem as promulgated in Navy Order 466 of 1943 shall be transferred to the Africa Star, and that the silver rose emblem issued shall cease to be worn on the 1939-45 Star ribbon but shall be worn instead on the Africa Star ribbon.

The qualifications for this clasp are shown in the Appendix to this Order.

4. QUALIFICATIONS FOR THE ATLANTIC STAR.—(A) Six months' service afloat as defined in Section III., paragraphs (A)-(G) or (in the case of air crews) two months' service in the Atlantic Ocean and/or home waters between 3rd September, 1939, and the 8th May, 1945.

(B) Service in home waters, service on the convoy routes to North Russian ports, service in the South Atlantic between the longitude of Cape Horn and longitude 20° E., including service in minesweepers that at any time within the relevant dates acted as escort or patrol vessels, will count towards qualification for the Atlantic Star, as well as service in ships based on Gibraltar (excluding any time served in the Mediterranean).

(C) Service in Force H after 9th November, 1942, will not count towards qualification for the Atlantic Star.

(D) Service in ships employed solely for the defence of a port (e.g., sea-going boom defence and examination service vessels) will not be held to qualify for the Atlantic Star, since such service is adequately recognized by the 1939-45 Star.

(E) Service afloat or in the air on and after 6th June, 1944, south of a line from the Firth of Forth to Kristiansand (South), in the English Channel, or in the Bay of Biscay east of longitude 6° W., since it qualifies for the France and Germany Star, and the Atlantic and France and Germany Star are alternatives, will not count towards qualification for the Atlantic Star.

5. QUALIFICATIONS FOR THE AIR CREW EUROPE STAR.—

(A) Two months' service in the period between 3rd September, 1939, and 5th June, 1944 (both dates inclusive), in air crews making operational flights over Europe (including the United Kingdom) from bases in the United Kingdom.

(B) Air crew service in operations at sea is not a qualification for the Air Crew Europe Star.

6. QUALIFICATIONS FOR THE ITALY STAR.—(A) For the Army, entry into operational service on land subsequent to the capture of Pantellaria on the 11th June, 1943, in Sicily until the 17th August, 1943, in Sardinia until the 19th September, 1943, and in Italy, in Elba (being regarded for the purpose as part of Italy), in the Aegean Sea, and the Dodecanese Islands, in Greece and in Yugoslavia up till the 8th May, 1945.

(B) For the Navy, service afloat or in the air (including sorties from the Mediterranean over Europe) between the 11th June, 1943, and the 8th May, 1945, in direct connexion with active operations in the areas set forth in paragraph (A) including Cretan and Albanian waters, and in Naval operations in connexion with the invasion of the South of France, or service on shore, if appointed or drafted for such service, in the areas qualifying the Army as set forth in paragraph (A).

(C) Service in all ships in the Mediterranean Command after the 11th June, 1943, will qualify except—

- (i) Ships on passage through or working up in the Mediterranean ;
- (ii) Ships based on Gibraltar, North African, Palestinian and Cypriot ports, unless they were directly connected with active operations as defined in paragraph (B).

7. QUALIFICATIONS FOR THE FRANCE AND GERMANY STAR.—

(A) Service afloat or in the air between 6th June, 1944, and the 8th May, 1945, in the North Sea south of a line from the Firth of Forth to Kristiansand (South), in the English Channel and in the Bay of Biscay east of longitude 6° W., provided such service was directly in support of land operations in France, Belgium, Holland, Germany, etc.

(B) Service on shore, if appointed or drafted for such service, in France, Belgium, Holland or Germany on or after 6th June, 1944.

(C) Service afloat or in the air in the Mediterranean in support of operations in the South of France does not qualify for the France and Germany Star.

8. QUALIFICATIONS FOR THE PACIFIC STAR.—(A) Service afloat or in the air on or after the 8th December, 1941, in the Pacific Ocean, including the South China Sea, and the Indian Ocean east of a line running due south from Singapore round the south-east coast of Sumatra, through Christmas Island, and southwards along the meridian of 110° E.

(B) Service ashore, if appointed or drafted for such service, in—

	<i>From—</i>	<i>To—</i>
Hong Kong	8th December, 1941	25th December, 1941
Malaya	8th December, 1941	15th February, 1942
Nauru	8th December, 1941	1st March, 1942
Ocean Island	8th December, 1941	26th August, 1942
Gilbert and Ellice Islands ..	10th December, 1941	15th August, 1945
Borneo and Sarawak	17th December, 1941	31st January, 1942
Celebes	10th January, 1942	26th February, 1942
Bismarek Archipelago	22nd January, 1942 15th December, 1943	24th January, 1942 15th August, 1945
Molucca Islands	30th January, 1942	26th February, 1942
Solomon Islands (British Solomon Islands Protec- torate and Australian Mandated Territory)	1st February, 1942	15th August, 1945
Sumatra	14th February, 1942	23rd March, 1942
Timor	20th February, 1942	31st March, 1942
Java	27th February, 1942	9th March, 1942
New Guinea	7th March, 1942	15th August, 1945

(C) Casual entry into the area qualifying for the Pacific Star, as, for instance, service in ships of the East Indies Station that crossed the western boundary of the area (as laid down in paragraph (A) above) for the sole purpose of fuelling, etc., in Western Australia will not be a qualification for the Pacific Star.

(D) Anyone who has qualified for the Burma Star is not eligible to receive the Pacific Star, but, if he subsequently qualifies for the Pacific Star, he will receive a clasp denoted by a silver rose emblem to be worn on the ribbon of the Burma Star.

9. QUALIFICATIONS FOR THE BURMA STAR.—(A) Services afloat or in the air on and after the 11th December, 1941, in that part of the Bay of Bengal enclosed by a line running from the southernmost point of Ceylon for a distance of 300 miles south, thence to a point 300 miles west of the southernmost point of Sumatra and continuing east to the western side of Sunda Strait; and in the Malacca Strait.

(B) Service ashore, if appointed or drafted for such service, in—

	<i>From—</i>	<i>To—</i>
Burma	11th December, 1941	15th August, 1945
The provinces of Bengal and Assam	1st May, 1942	31st December, 1943
Those parts of the provinces of Bengal and Assam east of the Brahmaputra river	1st January, 1944	15th August, 1945
Sumatra and Malaya ..	1st November, 1943	15th August, 1945

(C) Casual entry into the area qualifying for the Burma Star, as, for instance, service in ships proceeding from Colombo to Trincomalee in order to refit, will not be a qualification for the Burma Star.

(D) Anyone who has qualified for the Pacific Star is not eligible to receive the Burma Star, but, if he subsequently qualifies for the Burma Star, he will receive a clasp denoted by a silver rose emblem to be worn on the ribbon of the Pacific Star.

10. QUALIFICATIONS FOR THE DEFENCE MEDAL.—(A) Three years' service on shore since 3rd September, 1939, in the United Kingdom.

(B) One year's service on shore since 3rd September, 1939, in non-operational areas overseas from or outside the country of residence (e.g., for a Canadian, one year's service in the United Kingdom, or for an Englishman, one year's service in India).

(C) Three months' service since 3rd September, 1939, in active mine and bomb disposal duties in the United Kingdom.

(D) Three years', or one year's service, as the case may be, in administrative duties in connexion with mine and bomb disposal.

(ii) Service may be aggregated, but time overseas in non-operational areas amounting to less than a year will be added at its actual time value to service of less than three years at home, that is to say, it will not be multiplied by three.

(iii) Those qualified for any one of the Campaign Stars may be granted the Defence Medal in addition, and the subsequent award of one of the Campaign Stars will not supersede a previous grant of the Defence Medal.

(iv) Service qualifying for the Defence Medal, if brought to an end before the period of three years or twelve or three months' service has been completed, either by death due to enemy action when on duty, or by injuries entitling the candidate for a wound stripe, will be a qualification for the grant of the Defence Medal. In the event of death, no issue of the ribbon will be made, but the medal, when manufactured, will be sent to the next-of-kin.

(v) The receipt of an award or commendation in respect of service qualifying for the Defence Medal qualifies for the medal without regard to the three years' or twelve or three months' service requirement.

(vi) The closing date of the qualifying period for the Defence Medal in respect of service in the Royal Navy will be 8th May, 1945, the date on which active hostilities ended in Europe. Qualifying service overseas as defined in paragraph (B) above will continue to be reckoned until the end of active hostilities in the Pacific.

SECTION IV.

1. The ribbons and emblems of the Atlantic Star, Air Crew Europe Star, Italy Star, France and Germany Star, Pacific Star, and Burma Star, and, if not already issued, of the 1939-45 Star and the Africa Star, should be issued without delay to those who have qualified for them, as soon as supplies are available.

The following are general instructions for the issue of the ribbons and emblems:—

(a) It is the intention that the ribbons and emblems should be issued to serving officers and ratings entitled to receive them by the ships, establishments, etc., in which they are borne. Entitlement should be checked as far as possible from Service documents or other available information (in some cases of doubt, depots may be able to assist), but Commanding Officers are authorized to issue the ribbon and emblems provided they feel satisfied that the qualifying conditions have been fulfilled. Only in very exceptional cases should reference be made to the Naval Board. In all cases it should be made clear that the issue is provisional only and does not confirm the title of the recipient to the award of the Star or clasp.

It is suggested that the duty of checking claims from ratings should be carried out by their Divisional Officers.

(b) Record should be kept of those to whom ribbons or emblems have been issued on Form A.S. 1129z of which a model is shown below. This is a common form designed for use in the issue of the ribbons of all the Campaign Stars and of the Defence Medal and of the emblems denoting clasps to the Stars. Supplies of the form in question will be issued, on demand, by the Superintending Naval Store Officer, Garden Island, Sydney. On completion, the form is to be forwarded to the Secretary, Naval Board.

RECORD OF ISSUE OF RIBBON OF CAMPAIGN STARS.

400

H.M.A.S. "....."

Date

The Ribbon of the Campaign Stars shown below has been issued to the officers/men listed below for the services shown in Column 4. By their signature in Column 6 these officers/men acknowledge receipt of the ribbon on the understanding that its award is based on the best evidence available in this ship (or establishment), is provisional only and is liable to withdrawal if check at Navy Office shows them not to be entitled and that it gives no claim to the award of the Stars themselves.

Full Name (in block type) and Rank or Rating and Official Number. (1)	Campaign Star (2)	Rosette or Emblem Claimed. (3)	Qualifying Service.* (4)	1939-45 Ribbon Issued. (5)	Signature. (6)
Williamson, Fredk. J., S.B.A. 21111	Africa	Yes	Quiberon .. 11. 5. 42—23. 5. 43	Yes	
Johnson, Edwin F., L/Sea., W. 8126	1939-45 and Pacific	No	New Guinea .. 1. 6. 43—25. 11. 43 Hobart .. 1. 12. 43—2. 4. 44	No	
Smith, Robert J., A.B., P.M. 1006	1939-45 and Pacific Atlantic	No	H.M.S. <i>Nonsuch</i> 1. 10. 39—1. 8. 41 Hobart .. 3. 2. 42—2. 12. 43	No	

* In this column should be stated the ground on which the ribbon has been issued, i.e., whether it has been issued for six months or for the qualifying period of service with the Army or Air Force (in which case the dates of this service should be given and the names of the ships in which it was done) or for the qualifying period of service with the Army or Air Force (in which case also dates and areas should be given) or for the possession of an hour, decoration, medal or mention in despatches for services in specified operations for any other service in specified operations, or for any other service accepted by the Commanding Officer as qualifying.

If an issue of 1939-45 ribbon has been made previously, state "Yes" in Column 5.

To the Secretary,

Naval Board,

Department of the Navy, Melbourne.

Commanding Officer.

14

15

400

SUMMARY OF AWARDS.

- 1939-45 Star Ribbon.
- Silver gilt rose denoting Battle of Britain Clasp.
- Africa Star ribbon.
- Silver Rose
- "1"
- "8"
- Atlantic Star ribbon.
- Silver Rose for recipients of France and Germany or Air Crew Europe Star, if qualified for Atlantic Star (one rose only to be issued).
- Air Crew Europe Star ribbon.
- Silver Rose for recipients of Atlantic or France and Germany Stars if qualified for Air Crew Europe Star (one rose only to be issued).
- Italy Star ribbon.
- France and Germany Star ribbon.
- Silver Rose for recipients of Atlantic Star or Air Crew Europe Star, if qualified for France and Germany Star (one rose only to be issued).
- Pacific Star ribbon.
- Silver Rose for recipients of Burma Star, if qualified for Pacific Star.
- Burma Star ribbon.
- Silver Rose for recipients of Pacific Star if qualified for Burma Star.
- Defence Medal.

NOTE.—Anyone who has 7 may have 10 or 13 if he has qualified for them, but may not have both. Similarly, anyone who has 9 may have 8 or 13, but not both and anyone who has 12 may have 8 or 10 but not both.

RIBBONS.

Applications for bulk quantities of ribbons for the various Stars on the basis of a length of 2½ inches for each individual should be addressed by H.M.A. Ships and Establishments to the Superintending Victualling Store Officer, Royal Edward Victualling Yard, Sydney, stating the quantity in yards or feet required.

Applications for the Rosette should be forwarded to the Secretary, Naval Board, Melbourne.

2. COMBINED OPERATIONS PERSONNEL.—The instructions in paragraph 1 (a) of this Section above are not entirely applicable to combined operations personnel who are all borne in H.M.S. *Copra*. In their case therefore, the following instructions should be substituted:—

Issue of ribbons and emblems to combined operations personnel should be regarded as a matter of local administration and carried out as such in accordance with C.A.F.O. 1732/43. Entitlement should be checked as far as possible from Service documents or other available information, but Commanding Officers are authorized to issue the ribbon, rosettes and emblems, provided they feel satisfied that the qualifying conditions have been fulfilled. Reference to H.M.S. *Copra* or to the Naval Board should be resorted to only in exceptional circumstances when the information available locally is thought to be unreliable. In all cases it should be made clear that the issue is provisional only, and does not confirm the title of the recipient to the award of the Star or Clasp.

3. A further announcement will be made about the issue of ribbon and emblems to officers and men discharged from the Service.

4. Officers serving on headquarters staffs should make application to the Secretary, Naval Board.

APPENDIX.

Qualifications for the clasp to the Africa Star denoted by the Silver Rose Emblem to be worn on the ribbon of the Africa Star:—Service in the Mediterranean or Levant Commands between 23rd October, 1942, and the 12th May, 1943, inclusive;

(a) in any of the following ships:—

R.F.A. <i>Abbeydale.</i>	H.M.S. <i>Bachaquero.</i>
H.M.S. <i>Abdiel.</i>	H.M.C.S. <i>Baddeck.</i>
H.M.S. <i>Aberdare.</i>	H.M.S. <i>Badsworth.</i>
H.M.S. <i>Achates.</i>	H.M.S. <i>Baqshot.</i>
H.M.S. <i>Achroite.</i>	H.M.S. <i>Balna.</i>
H.M.S. <i>Acute.</i>	H.M.S. <i>Banff.</i>
H.M.S. <i>Adventure.</i>	H.M.S. <i>Barbarian.</i>
H.M.S. <i>Aegina.</i>	H.M.S. <i>Bardolf.</i>
H.M.S. <i>Ajax.</i>	H.M.S. <i>Barflake.</i>
H.M.S. <i>Alarm.</i>	H.M.S. <i>Barfoil.</i>
H.M.S. <i>Abacore.</i>	H.M.S. <i>Barford.</i>
H.M.C.S. <i>Alberni.</i>	H.M.S. <i>Barhill.</i>
H.M.S. <i>Albrighton.</i>	H.M.S. <i>Barmond.</i>
H.M.S. <i>Aldenham.</i>	H.M.S. <i>Barwell.</i>
H.M.S. <i>Algerine.</i>	H.M.S. <i>Barwind.</i>
H.M.C.S. <i>Algoma.</i>	H.M.S. <i>Barwick.</i>
H.M.S. <i>Alynbank.</i>	H.M.S. <i>Beagle.</i>
H.M. Hospital Ship <i>Amarapoor.</i>	H.M.S. <i>Beaufort.</i>
H.M.S. <i>Amazon.</i>	H.M.S. <i>Belvoir.</i>
H.M.S. <i>Amber.</i>	H.M.S. <i>Beryl.</i>
H.M.S. <i>Amin.</i>	H.M.S. <i>Bermuda.</i>
H.M.S. <i>Anglia.</i>	H.M.S. <i>Bever.</i>
H.M.S. <i>Antelope.</i>	H.M.S. <i>Bicester.</i>
H.M.S. <i>Anthony.</i>	H.M.S. <i>Bideford.</i>
H.M.S. <i>Antwerp.</i>	H.M.S. <i>Birdip.</i>
H.M.S. <i>Aphis.</i>	H.M.S. <i>Biter.</i>
H.M.S. <i>Aquila.</i>	H.M.S. <i>Blean.</i>
H.M.S. <i>Archer.</i>	H.M.S. <i>Boadicea.</i>
H.M.S. <i>Arethusa.</i>	H.M.S. <i>Boksburg.</i>
H.M.S. <i>Arctic Ranger.</i>	H.M.S. <i>Bonito.</i>
H.M.S. <i>Ardrossan.</i>	H.M.S. <i>Borde.</i>
H.M.S. <i>Argonaut.</i>	H.M.S. <i>Borealis.</i>
H.M.S. <i>Argus.</i>	H.M.S. <i>Boreas.</i>
H.M.S. <i>Armeria.</i>	H.M.S. <i>Boston.</i>
H.M.S. <i>Armoun.</i>	H.M.S. <i>Bramham.</i>
H.M.S. <i>Arnold Bennett.</i>	H.M.S. <i>Bream.</i>
H.M.S. <i>Aroussa.</i>	H.M.S. <i>Brigand.</i>
H.M.S. <i>Ashanti.</i>	H.M.S. <i>Brilliant.</i>
H.M.S. <i>Atherstone.</i>	H.M.S. <i>Brizham.</i>
H.M.S. <i>Aubretia.</i>	H.M.S. <i>Brocklesby.</i>
H.M.S. <i>Aurora.</i>	H.M.S. <i>Broke.</i>
H.M.S. <i>Avenger.</i>	R.F.A. <i>Brown Ranger.</i>
H.M.S. <i>Avonvale.</i>	H.M.S. <i>Bude.</i>
H.M.S. <i>Azalea.</i>	H.M.S. <i>Bulldog.</i>

Appendix—continued.

H.M.S. <i>Bulolo.</i>	R.F.A. <i>Dingledale.</i>
H.M.S. <i>Burra.</i>	H.M.S. <i>Duke of York.</i>
H.M.S. <i>Burget.</i>	H.M.S. <i>Dulverton.</i>
H.M.S. <i>Burke.</i>	H.M.S. <i>Dunbar.</i>
H.M.S. <i>Burwell.</i>	
H.M.S. <i>Butser.</i>	H.M.S. <i>Easton.</i>
	H.M.S. <i>Eday.</i>
H.M.S. <i>C.307.</i>	H.M.S. <i>Eggesford.</i>
H.M.S. <i>Cadmus.</i>	H.M.S. <i>Elbury.</i>
H.M.S. <i>Calm.</i>	H.M.S. <i>El Hannan.</i>
H.M.S. <i>Calpe.</i>	H.M.S. <i>Eminent.</i>
H.M.S. <i>Camellia.</i>	H.M.S. <i>Empire Ann.</i>
H.M.C.S. <i>Camrose.</i>	H.M.S. <i>Empire Edward.</i>
H.M.S. <i>Carlisle.</i>	H.M.S. <i>Empire Fred.</i>
H.M.S. <i>Cava.</i>	H.M.S. <i>Empire Gnome.</i>
H.M.S. <i>Charles McIver.</i>	H.M.S. <i>Empire Minnow.</i>
H.M.S. <i>Charon.</i>	H.M.S. <i>Empire Monotaur.</i>
H.M.S. <i>Charybdis.</i>	H.M.S. <i>Empire Spitfire.</i>
R.F.A. <i>Cherryleaf.</i>	H.M.S. <i>Empire Titania.</i>
H.M.S. <i>Circe.</i>	H.M.S. <i>Empyrean.</i>
H.M.S. <i>Clacton.</i>	H.M.S. <i>Enchantress.</i>
H.M.S. <i>Clare.</i>	H.M.S. <i>Energetic.</i>
H.M.S. <i>Cleopatra.</i>	R.F.A. <i>Ennerdale.</i>
H.M.S. <i>Cleveland.</i>	H.M.S. <i>Erica.</i>
H.M.S. <i>Clyde.</i>	H.M.S. <i>Erne.</i>
H.M.S. <i>Clyne Castle.</i>	H.M.S. <i>Escapade.</i>
H.M.S. <i>Coltsfoot.</i>	H.M.S. <i>Eskdale.</i>
H.M.S. <i>Confederate.</i>	H.M.S. <i>Eskimo.</i>
H.M.S. <i>Convolvulus.</i>	H.M.S. <i>Espiegle.</i>
H.M.S. <i>Coreopsis.</i>	H.M.S. <i>Euryalus.</i>
H.M.S. <i>Coriolanus.</i>	H.M.S. <i>Eze.</i>
H.M.S. <i>Coverley.</i>	H.M.S. <i>Ezmoor.</i>
H.M.S. <i>Cowdray.</i>	H.M.S. <i>Falk.</i>
H.M.S. <i>Cowslip.</i>	H.M.S. <i>Fantome.</i>
H.M.S. <i>Crocus.</i>	H.M.S. <i>Fareham.</i>
H.M.S. <i>Cromarty.</i>	H.M.S. <i>Farnedale.</i>
H.M.S. <i>Cromer.</i>	H.M.S. <i>Favourite.</i>
H.M.S. <i>Croome.</i>	H.M.S. <i>Felixstowe.</i>
H.M.S. <i>Cumberland.</i>	H.M.S. <i>Filey Bay.</i>
H.M.S. <i>Cumbrae.</i>	H.M.S. <i>Fishguard.</i>
H.M.S. <i>Cyclamen.</i>	H.M.S. <i>Fleetwood.</i>
H.M.S. <i>Cyrus Joseph.</i>	H.M.S. <i>Fluellen.</i>
	H.M.S. <i>Folkestone.</i>
H.M.S. <i>Dasher.</i>	H.M.S. <i>Formidable.</i>
H.M.S. <i>Delhi.</i>	H.M.S. <i>Foula.</i>
H.M.S. <i>Delphinium.</i>	H.M.S. <i>Foztrot.</i>
H.M.S. <i>Deptford.</i>	H.M.S. <i>Furious.</i>
H.M.S. <i>Derby.</i>	
H.M.S. <i>Derwent.</i>	H.M.S. <i>Gamtoos.</i>
R.F.A. <i>Derwentdale.</i>	H.M.S. <i>Gardenia.</i>
R.F.A. <i>Deudale.</i>	H.M.S. <i>Gavotte.</i>
H.M.S. <i>Dianella.</i>	H.M.S. <i>General Birdwood.</i>
H.M.S. <i>Dido.</i>	H.M.S. <i>Geranium.</i>

Appendix—continued.

H.M.S. *Girl Margaret*.
H.M.S. *Glengyle*.
H.M.S. *Gloxinia*.
H.M.S. *Goathland*.
H.M.S. *Gorleston*.
H.M.S. *Goth*.
H.M.S. *Grayling*.
H.M.S. *Gregory*.
H.M.S. *Grib*.
H.M.S. *Guardian*.

H.M.S. *Haarlem*.
H.M.S. *Hailstorm*.
H.M.S. *Halcyon*.
H.M.S. *Harrow*.
H.M.S. *Hartland*.
H.M.S. *Haydon*.
H.D.M.Ls. 1121, 1123, 1127, 1128,
1130, 1131, 1132, 1133, 1134,
1139, 1142, 1146, 1152, 1154,
1162, 1210, 1221, 1225, 1235,
1237.
H.M.S. *Hebe*.
H.M.S. *Hektor* 7.
H.M.S. *Helvig*.
H.M.S. *Hengist*.
H.M.S. *Henrietta Moller*.
H.M.S. *Hero*.
H.M.S. *Holcombe*.
H.M.S. *Honeysuckle*.
H.M.S. *Horatio*.
H.M.S. *Hoy*.
H.M.S. *Hudson*.
H.M.S. *Hunda*.
H.M.S. *Hunter*.
H.M.S. *Hursley*.
H.M.S. *Hurworth*.
H.M.S. *Hussar*.
H.M.S. *Hyacinth*.
H.M.S. *Hyderabad*.
H.M.S. *Hythe*.

H.M.S. *Ibis*.
H.M.S. *Ilex*.
H.M.S. *Imhoff*.
H.M.S. *Imperialist*.
H.M.S. *Inchcolm*.
H.M.S. *Inchmarnock*.
H.M.S. *Isis*.
H.M.S. *Islay*.
H.M.S. *Ithurial*.

H.M.S. *Jamaica*.
H.M.S. *Jaunty*.

H.M.S. *Javelin*.
H.M.S. *Jeddah*.
H.M.S. *Jervis*.
H.M.S. *Jonquil*.
H.M.S. *Juliet*.
H.M.S. *Jura*.

H.M.S. *Kai*.
H.M.S. *Karanja*.
H.M.I.S. *Kathiawar*.
H.M.S. *Kelvin*.
H.M.S. *Keren*.
H.M.S. *Kerrera*.
H.M.S. *King George V*.
H.M.S. *King Salvor*.
H.M.S. *King Sol*.
H.M.S. *Kingston Chrysolite*.
H.M.S. *Kingston Crystal*.
H.M.S. *Kingston Cyanite*.
H.M.S. *Kintyre*.
H.M.C.S. *Kitchener*.
H.M.S. *Klo*.
H.M.I.S. *Kumaon*.
H.M.L.C.Ms. 26, 54, 57, 58, 61, 79,
80, 83, 98, 105 (N.S.B. 18), 112,
139, 141, 144.
H.M.L.C.Ps. 68, 100, 103, 104, 106,
112, 162.
H.M.L.C.P(L)s. 56 (N.A.B. 18), 126.
H.M.L.C.Ts. 3, 7, 9, 13, 17, 18,
100, 101, 104, 106, 107, 108,
111, 112, 113, 114, 115, 116,
117, 118, 120, 129, 135, 138,
139, 149, 152, 153, 154, 157,
158, 160, 164, 169, 170.
H.M.L.S.T. 304.

H.M.S. *Ladyhogarth*.
H.M.S. *Laforey*.
H.M.S. *Lamerton*.
H.M.S. *Lancaster*.
H.M.S. *Landguard*.
H.M.S. *Lapageria*.
H.M.S. *Largs*.
H.M.S. *Lariat*.
H.M.S. *Lasso*.
H.M.S. *Lauderdale*.
H.M.S. *Laurel*.
H.M.S. *Leith*.
H.M.S. *Leonian*.
H.M.S. *Leyland*.
H.M.S. *Liddesdale*.
H.M.S. *Lightning*.

Appendix—continued.

H.M.S. *Linnet*.
H.M.S. *Llangiaagte*.
H.M.S. *Loch Oskaig*.
H.M.S. *Londonderry*.
H.M.S. *Lookout*.
H.M.S. *Lord Hotham*.
H.M.S. *Lord Nuffield*.
H.M.S. *Lotus*.
H.M.C.S. *Louisburg*.
H.M.S. *Loyal*.
H.M.S. *Lulworth*.
H.M.C.S. *Lunenburg*.
H.M.M.B. 4157.
H.M.M.G.Bs. 641 642, 643, 644,
645, 646, 647.
H.M.M.Ls. 121, 126, 134, 135, 168,
170, 172, 173, 174, 175, 176,
238, 258, 273, 280, 283, 295,
307, 336, 338, 341, 348, 349,
350, 351, 354, 355, 356, 357,
358, 359, 443, 444, 449, 458,
459, 460, 462, 463, 468, 469,
471, 480, 483, 493, 494, 554,
555, 556, 557, 560, 561, 564,
566, 1012, 1028, 1032, 1046,
1051, 1122, 1126, 1136, 1138,
1149, 1158, 1159, 1163, 1165,
1211, 1222, 1227, 1230, 1232,
1233, 1234, 1236, 1239, 1240,
1241, 1250, 1251.
H.M.M.F.V. 2033, 2034, 2035.
H.M.M.M.S. 1, 5, 9, 13, 20, 21, 33,
46, 47, 53, 58, 63, 65, 68, 70,
71, 80, 81, 85, 88, 89, 92, 113,
114, 116, 118, 133, 134, 135,
140, 171, 184.
H.M.M.T.Bs. 61, 62, 65, 73, 75, 76,
77, 78, 82, 84, 95, 260, 261, 262,
264, 265, 266, 267, 268, 307,
309, 311, 313, 315, 316, 633,
634, 635, 636, 637, 638, 639,
640, 651, 656.

H.M.S. *Magnet*.
H.M.S. *Magnetic*.
H.M.S. *Maidstone*.
H.M. Hospital Ship *Maine*.
H.M.S. *Malcolm*.
H.M.S. *Man o' War*.
H.M.S. *Manxman*.
H.M.S. *Maple*.
H.M.S. *Marigold*.
H.M.S. *Marne*.

H.M.S. *Martin*.
H.M.S. *Mastadonte*.
H.M.S. *Meteor*.
H.M.S. *Milne*.
H.M.S. *Minna*.
H.M.S. *Mirror*.
H.M.S. *Misoo*.
H.M.C.S. *Moosejaw*.
H.M.S. *Moray*.
H.M.C.S. *Morden*.
H.M.S. *Mull*.
H.M.S. *Mullet*.

R.F.A. *Nasprite*.
H.M.S. *Nasturtium*.
H.M.S. *Negro*.
H.M.S. *Nelson*.
H.M.S. *Neptune*.
H.M.S. *Newfoundland*.
H.M.S. *Nimble*.
H.M.S. *Norfolk*.
H.M.S. *Northern Foam*.
H.M.S. *Northern Gift*.
H.M.S. *Nubian*.

H.M.S. *Oakley*.
H.M.S. *Offa*.
H.M.S. *Onslow*.
H.M.S. *Opportune*.
H.M.S. *Oribi*.
H.M.S. *Orion*.
H.M.S. *Othello*.
H.M. Hospital Ship *Oxfordshire*.
H.M.S. *Oxlip*.

H.M.S. *P. 48*.
H.M.S. *P. 222*.
H.M.S. *P. 311*.
H.M.S. *Pakenham*.
H.M.S. *Paladin*.
H.M.S. *Palomares*.
H.M.S. *Panther*.
H.M.S. *Parthian*.
H.M.S. *Partridge*.
H.M.S. *Pathfinder*.
H.M.S. *Payday*.
H.M.S. *Pelican*.
H.M.S. *Penelope*.
H.M.S. *Penn*.
H.M.S. *Pentstemon*.
H.M.S. *Petard*.
R.F.A. *Petrella*.
H.M.S. *Philante*.

Appendix—continued.

H.M.S. <i>Phyllisia.</i>	H.M.S. <i>Ruskholm.</i>
H.M.S. <i>Ploughboy.</i>	H.M.S. <i>Rye.</i>
H.M.S. <i>Pirouette.</i>	H.M.S. <i>Rysa.</i>
H.M.S. <i>Polruan.</i>	
H.M.S. <i>Poole.</i>	H.M.S. <i>Sabi.</i>
H.M.S. <i>Poppy.</i>	H.M.S. <i>Safari.</i>
H.M.S. <i>Porcupine.</i>	H.M.S. <i>Sahib.</i>
H.M.S. <i>Porpoise.</i>	H.M.S. <i>Sahra.</i>
H.M.C.S. <i>Port Arthur.</i>	H.M.S. <i>Salamander.</i>
H.M.S. <i>Pozarica.</i>	H.M.S. <i>Salventure.</i>
H.M.C.S. <i>Prescott.</i>	H.M.S. <i>Salvestor.</i>
H.M.S. <i>Primula.</i>	H.M.S. <i>Salvonja.</i>
H.M.S. <i>Princess Beatrix.</i>	H.M.S. <i>Samika.</i>
H.M.S. <i>Protea.</i>	H.M.S. <i>Samphire.</i>
H.M.S. <i>Puckeridge.</i>	H.M.S. <i>Samsonia.</i>
H.M.S. <i>Punnet.</i>	H.M.S. <i>Sandwich.</i>
	H.M.S. <i>Santa.</i>
H.M.S. <i>Quadrant.</i>	H.M.S. <i>Saracen.</i>
H.M.S. <i>Quality.</i>	H.M.S. <i>Sayonara.</i>
H.M.S. <i>Quannet.</i>	H.M.S. <i>Saxifrage.</i>
H.M.S. <i>Quantock.</i>	H.M.S. <i>Scarborough.</i>
H.M.S. <i>Queen Emma.</i>	H.M.S. <i>Scottish.</i>
H.M.S. <i>Quentin.</i>	H.M.S. <i>Scylla.</i>
H.M.S. <i>Quercia.</i>	H.M.S. <i>Seaham.</i>
H.M.S. <i>Quiberon.</i>	H.M.S. <i>Seksern.</i>
H.M.S. <i>Quickmatch.</i>	H.M.S. <i>Sennen.</i>
	H.M.S. <i>Seraph.</i>
H.M.S. <i>Raglan Castle.</i>	H.M.S. <i>Servasti.</i>
H.M.S. <i>Rambler.</i>	H.M.S. <i>Shakespeare.</i>
H.M.S. <i>Redoubt.</i>	H.M.S. <i>Sheffield.</i>
H.M.S. <i>Redwood.</i>	H.M.S. <i>Shiant.</i>
H.M.S. <i>Regent.</i>	H.M.S. <i>Shippigan.</i>
H.M.C.S. <i>Regina.</i>	H.M.S. <i>Shuttle.</i>
H.M.S. <i>Reighton Wyke.</i>	H.M.S. <i>Sibyl.</i>
H.M.S. <i>Renown.</i>	H.M.S. <i>Slekie.</i>
H.M.S. <i>Resource.</i>	H.M.S. <i>R.H. Sidway.</i>
H.M.S. <i>Restive.</i>	H.M.S. <i>Sirius.</i>
H.M.S. <i>Returno.</i>	H.M.S. <i>Skudd IV.</i>
H.M.S. <i>Rhododendron.</i>	H.M.S. <i>Skudd V.</i>
H.M.S. <i>Rhyl.</i>	H.M.S. <i>Snapdragon.</i>
H.M.S. <i>Roberts.</i>	H.M.S. <i>Southern Isles.</i>
H.M.S. <i>Rochester.</i>	H.M.S. <i>Southern Maid.</i>
H.M.S. <i>Rockwood.</i>	H.M.S. <i>Southern Sea.</i>
H.M.S. <i>Rodney.</i>	H.M.S. <i>Speedwell.</i>
H.M.S. <i>Romeo.</i>	H.M.S. <i>Speedy.</i>
H.M.S. <i>Romney.</i>	H.M.S. <i>Spey.</i>
H.M.S. <i>Ronaldshay.</i>	H.M.S. <i>Splendid.</i>
H.M.S. <i>Rorqual.</i>	H.M.S. <i>Spider.</i>
H.M.S. <i>Rother.</i>	H.M.S. <i>Spirea.</i>
H.M.S. <i>Rothesay.</i>	H.M.S. <i>Sportsman.</i>
H.M.S. <i>Rousay.</i>	H.M.S. <i>St. Charles.</i>
H.M.S. <i>Royal Scotsman.</i>	H.M.C.S. <i>St. Croix.</i>
H.M.S. <i>Royal Ulsterman.</i>	H.M.S. <i>St. Day.</i>

Appendix—continued.

H.M.S. <i>St. Issey.</i>	H.M.S. <i>Unbending.</i>
H.M.S. <i>St. Mellons.</i>	H.M.S. <i>Unbroken.</i>
H.M.S. <i>St. Minver.</i>	H.M.S. <i>Unison.</i>
H.M.S. <i>St. Monance.</i>	H.M.S. <i>United.</i>
H.M.S. <i>St. Nectan.</i>	H.M.S. <i>Unrivalled.</i>
H.M.S. <i>St. Omar.</i>	H.M.S. <i>Unruffled.</i>
H.M.S. <i>Starwort.</i>	H.M.S. <i>Unruly.</i>
H.M.S. <i>Stella Carina.</i>	H.M.S. <i>Unseen.</i>
H.M.S. <i>Stork.</i>	H.M.S. <i>Unshaken.</i>
H.M.S. <i>Stornoway.</i>	H.M.S. <i>Uproar.</i>
H.M.S. <i>Stroma.</i>	H.M.S. <i>Ursula.</i>
H.M.S. <i>Stronsay.</i>	H.M.S. <i>Utmost.</i>
H.M.S. <i>Sturdy.</i>	
H.M.S. <i>Sturgeon.</i>	H.M.S. <i>Valkyrien.</i>
H.M.C.S. <i>Summerside.</i>	H.M.S. <i>Vanoc.</i>
H.M.S. <i>Swale.</i>	H.M.S. <i>Vansittart.</i>
H.M.S. <i>Swona.</i>	H.M.S. <i>Velox.</i>
	H.M.S. <i>Venomous.</i>
H.M.S. <i>Tactician.</i>	H.M.S. <i>Verity.</i>
H.M.S. <i>Taku.</i>	H.M.S. <i>Vetch.</i>
H.M.S. <i>Tanatside.</i>	H.M.S. <i>Victoria II.</i>
H.M.S. <i>Tango.</i>	H.M.S. <i>Victorious.</i>
H.M.S. <i>Tarana.</i>	H.M.S. <i>Vienna.</i>
H.M.S. <i>Tartar.</i>	H.M.C.S. <i>Ville de Quebec.</i>
H.M.S. <i>Tasajera.</i>	H.M.S. <i>Vindictive.</i>
H.M.S. <i>Taurus.</i>	H.M.S. <i>Violet.</i>
H.M.S. <i>Tervani.</i>	H.M.S. <i>Visenda.</i>
H.M.S. <i>Test.</i>	
H.M.S. <i>Tetcott.</i>	H.M.S. <i>Walney.</i>
H.M.S. <i>Thalassa.</i>	H.M.S. <i>Waveney.</i>
H.M.S. <i>Thrasher.</i>	H.M.S. <i>Wear.</i>
H.M.S. <i>Thunderbolt.</i>	H.M.S. <i>Wellington.</i>
H.M.S. <i>Tigris.</i>	H.M.S. <i>Wells.</i>
H.M.S. <i>Torbay.</i>	H.M.S. <i>Welshman.</i>
H.M.S. <i>Toiland.</i>	H.M.S. <i>Westcott.</i>
H.M.S. <i>Transvaal.</i>	H.M.S. <i>Weston.</i>
H.M.S. <i>Traveller.</i>	H.M.S. <i>Westray.</i>
H.M.S. <i>Treern.</i>	H.M.C.S. <i>Weyburn.</i>
H.M.S. <i>Trespasser.</i>	H.M.S. <i>Wayland.</i>
H.M.S. <i>Tribune.</i>	H.M.S. <i>Whaddon.</i>
H.M.S. <i>Trident.</i>	H.M.S. <i>Wheatland.</i>
H.M.S. <i>Triton.</i>	H.M.S. <i>Whitehaven.</i>
H.M.S. <i>Trooper.</i>	H.M.S. <i>Whiting.</i>
H.M.S. <i>Tryme.</i>	H.M.S. <i>Wilton.</i>
H.M.S. <i>Turbulent.</i>	H.M.S. <i>Wimborne.</i>
H.M.S. <i>Tynedale.</i>	H.M.S. <i>Wishart.</i>
H.M.S. <i>Tynwald.</i>	H.M.S. <i>Wivern.</i>
	H.M.S. <i>Wolborough.</i>
H.M.S. <i>Uganda.</i>	H.M.S. <i>Woodpecker.</i>
H.M.S. <i>Ulster Monarch.</i>	H.M.S. <i>Woodruff.</i>
H.M.S. <i>Ulor.</i>	H.M.S. <i>Woodstock.</i>
H.M.S. <i>Umbra.</i>	H.M.S. <i>Woolwich.</i>
H.M.S. <i>Una.</i>	H.M.S. <i>Wren.</i>

Appendix—continued.

H.M.S. <i>Wrestler</i> .	H.Hell.M.S. <i>Papanicolis</i> .
H.M.S. X. 033.	H.Hell.M.S. <i>Pindos</i> .
H.M.S. <i>Ythan Braes</i> .	H.Hell.M.S. <i>Queen Olga</i> .
	H.Hell.M.S. <i>Saktouris</i> .
H.M. "Z" Craft 2, 6, 7, 8, 9, 12, 13, 14, 15, 16, 18, 19, 20, 21, 31, 34, 35, 36, 38, 41, 44.	H.Hell.M.S. <i>Spetsai</i> .
H.M.S. <i>Zetland</i> .	H.Hell.M.S. <i>Triton</i> .
H.M.S. <i>Zingarella</i> .	O.R.P. <i>Blyskawica</i> .
British Liaison Parties in H.Neth. M.S. <i>Dolfjn</i> .	O.R.P. <i>Dzik</i> .
H.Neth.M.S. <i>Isaac Sweers</i> .	O.R.P. <i>Sokol</i> .
H.Neth.M.S. <i>Schelde</i> .	French Ship <i>Antiope</i> .
H.Nor.M.S. <i>Glaisdale</i> .	French Ship <i>Casabianca</i> .
	French Ship <i>Commandant Domine</i> .
	French Ship <i>La Moqueuse</i> .
	French Ship <i>Marsouin</i> .
H.Hell.M.S. <i>Adrias</i> .	U.S.S. <i>Augusta</i> .
H.Hell.M.S. <i>Agios Georgios</i> .	U.S.S. <i>Barb</i> .
H.Hell.M.S. <i>Ierax</i> .	U.S.S. <i>Blackfish</i> .
H.Hell.M.S. <i>Kanaris</i> .	U.S.S. <i>Gunnel</i> .
H.Hell.M.S. <i>Katsonis</i> .	U.S.S. <i>Herring</i> .
H.Hell.M.S. <i>Kondouriotes</i> .	U.S.S. <i>Shad</i> .
H.Hell.M.S. <i>Miaoulis</i> .	Yugoslav Ship <i>Durmator</i> .
H.Hell.M.S. <i>Nereus</i> .	Yugoslav Ship <i>Kajmakaian</i> .

or

- (b) in landing craft employed in ferrying stores for the First Army which operated East of Bone between 23rd October, 1942, and 12th May, 1943, inclusive; or
- (c) in the Mobile Beach or Port Parties which operated on the coast of North Africa west of El Alamein between 23rd October, 1942, and 12th May, 1943, inclusive, or in permanent Port Parties established in that area during the same period; or
- (d) as Naval liaison personnel in merchant ships whose companies qualify under merchant navy rules. A list of these will be published later; or
- (e) Officers and men who served with the R.A.F. under the command of the Air Officer Commanding, Western Desert, or of the Air Commander, North West African Forces, or aircrews under the command of the Air Officer Commanding Malta, or of other air officers commanding, who operated in support of the Eighth or First Armies or in the cutting of Rommel's or von Arnim's communications or in the defence of Malta, from 23rd October, 1942, to 12th May, 1943, and officers and men who served with the R.A.F. under the command of the Air Officer Commanding Eastern Air Command, from 8th November, 1942, to 17th February, 1943,

Appendix—continued.

2. Any person who is qualified for the clasp denoted by the Silver Rose by service as set forth in paragraph 1 will be held to be qualified for the Africa Star.

3. Naval personnel, if any, who served as part of the Eighth or First Armies between 23rd October, 1942, and 12th May, 1943, will be held to have qualified not for the clasp denoted by the Silver Rose Emblem, but for that denoted by the 8th or 1st emblem.

4. Navy Orders 466 of 1943, 201 of 1944, and 56 and 296 of 1945 are hereby cancelled.

(448/201/1578.)

(This Order will be reprinted for posting on Notice Boards.)

RESTRICTED.(FOR OFFICIAL USE ONLY.)**Commonwealth Navy Orders.**

Navy Office, Melbourne,

18th September, 1945

The following Orders, having been approved, are hereby promulgated for information and guidance, and necessary action.

By direction of the Naval Board,

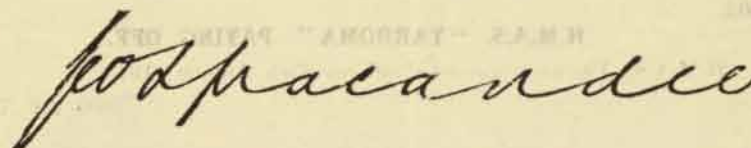

Secretary.

*The Commodore Commanding H.M.A. Squadron,
and Commanding Officers of H.M.A. Ships,
Officers in Charge of H.M.A. Naval
Establishments, and others concerned.*

TABLE OF CONTENTS.

No.	Subject.
401.	H.M.A. V.S.I.S. "Melinga"—Commissioning.
402.	H.M.A. G.P.V. 957—Commissioning.
403.	H.M.A. G.P.V. 958—Commissioning.
404.	H.M.A.S. "Flying Cloud"—Paying off.
405.	H.M.A.S. "Yarroma"—Paying off.
406.	South-West Pacific Area.
407.	Cartridges S.A. Oerlikon 20 mm.—Prematures.
408.	Components and Spares—Radar Equipment.
409.	Disposal of Effects of R.A.N. Personnel Reported Dead, Missing, Prisoners of War, Wounded or Sick.
410.	Radar Control and Radar Plot Scheme—Policy.
411.	H.M.S. "Pepys"—Commissioning.

401.

H.M.A. V.S.I.S. "MELINGA"—COMMISSIONING.

H.M.A. V.S.I.S. *Melinga* was commissioned on 1st September, 1945.
(674/205/3184.)

402.

H.M.A. G.P.V. 957—COMMISSIONING.

H.M.A. G.P.V. 957 was commissioned on 28th August, 1945.
(603/246/5326.)

403.

H.M.A. G.P.V. 958—COMMISSIONING.

H.M.A. G.P.V. 958 was commissioned on 6th September, 1945.
(603/246/5209.)

404.

H.M.A.S. "FLYING CLOUD"—PAYING OFF.

H.M.A.S. *Flying Cloud* was paid off on 28th August, 1945.
(603/246/5327.)

405.

H.M.A.S. "YARROMA"—PAYING OFF.

H.M.A.S. *Yarroma* was paid off on 25th August, 1945.
(603/246/5323.)

406.

SOUTH-WEST PACIFIC AREA.

On 2nd September, 1945, practically the whole of the South-West Pacific Area, excluding the Phillipines, reverted to British and Australian control and the Command—Allied Naval Forces, South-West Pacific Area—was abolished.

2. The Naval Board has assumed Naval responsibility for the eastern portion of this area and South-East Asia Command for the western portion.

3. All H.M.A. Ships, previously under the control of the Commander-in-Chief, South-West Pacific Area, have reverted to the control of Australian Commonwealth Naval Board.

4. Navy Order 334 of 1945 is to be amended by deleting the title "Commander Task Group 74.1".

(1937/2/330.)

407.

CARTRIDGES S.A. OERLIKON 20 mm.—PREMATURES.

Occasional prematures of cartridges S.A. Oerlikon 20 mm. of U.S. manufacture have been reported.

2. Cartridges of lots of U.S. manufacture will not necessarily be withdrawn when isolated prematures occur, but it is essential that reports of all such failures are made on the relevant Forms S. 1148.

(408/206/1558.)

408.

COMPONENTS AND SPARES—RADAR EQUIPMENT.

Components or spares of Admiralty, U.S.N. and R.A.N. types of Radar equipment required by H.M.A. Ships should be obtained from the undermentioned authorities, as indicated.

Type of Equipment.	Location of Ship.	Supply Authority.
Admiralty ..	Forward areas in company with R.N. N.S.I.S.	R.N. N.S.I.S.
	Forward areas not in company with R.N. N.S.I.S.	R.A.F.T. through Ship's Local Administrative Authority
	New Guinea area	S.N.S.O. (R.N.), Sydney
	Australian mainland	S.N.S.O. (R.N.), Sydney or N.S.O., Fremantle
		<i>Note.</i> —Limited quantities of spares are also held by the Officer-in-Charge, Naval Store Depot, Port Melbourne
U.S.N. ..	All locations	S.N.S.O. (R.N.), Sydney, through Ship's Local Administrative Authority
		<i>Note.</i> —Tender spares for U.S.N. Radar Type S.O. 13 are also held by— N.O.I.C., New Guinea N.S.O., Brisbane B.S.O., Darwin
R.A.N. ..	Forward areas in company with R.N. N.S.I.S.	R.N. N.S.I.S.
	Forward areas when supply from R.A.N. N.S.I.S. is practicable	R.A.N. N.S.I.S.
	Forward areas when supply from R.A.N. N.S.I.S. is not practicable	R.A.F.T. Through Ship's Local Administrative Authority
	New Guinea area	R.A.N. N.S.I.S.
	Australian mainland	Appropriate R.A.N. Naval Store Depot or Base Naval Store, Stocks are held at Sydney, Fremantle, Melbourne, Brisbane, Darwin and Adelaide

2. Demands, A.S.134d and requisitions for Survey, A.S.331 in respect of transactions with R.N. authorities referred to above, should be lodged in sextuplicate, as indicated also in paragraphs 7 and 17 of the R.A.N. Supplement to the Naval Storekeeping Manual, B.R. 4, and should invariably be headed "F. 1A Radar".

3. Confidential Commonwealth Navy Order 282 of 1944 is cancelled.

(2037/8/198.)

409.

DISPOSAL OF EFFECTS OF R.A.N. PERSONNEL REPORTED DEAD, MISSING, PRISONERS OF WAR, WOUNDED OR SICK.

With reference to Navy Orders 640 of 1944 and 264 of 1945, and Admiralty D.E.M.S. General Instruction No. 80, the following additional particulars are promulgated for the information of all concerned.

R.A.N. Personnel attached to Australian Military Forces, or where deaths occur in an A.M.F. Hospital.

- (i) The effects of R.A.N. personnel attached to the A.M.F. who are reported dead, missing, wounded or sick, or whose death occurs in a military hospital, will be forwarded by the Military Authorities to the Naval Officer-in-Charge of the nearest H.M.A. Naval Depot or, in the case of personnel attached to the A.M.F. who become prisoners of war, to the Commanding Officer, H.M.A.S. *Penguin*.
- (ii) Prior to despatch, an inventory of the effects will be made in triplicate, two copies of which will be forwarded to the Naval Officer-in-Charge of the nearest Naval Depot, or the Commanding Officer, H.M.A.S. *Penguin* (as appropriate), together with the request that one copy be receipted and returned to the forwarding Military authority. The third copy is to be forwarded to the Secretary, Department of the Navy, Melbourne.

D.E.M.S. R.A.N. Officers or Ratings.

In the case of death of a D.E.M.S., R.A.N. officer or rating, a complete list of all effects should be forwarded to the Commanding Officer, H.M.A.S. *Rushcutter*, for the purpose of his obtaining advice from Navy Office as to their disposal.

(557/201/231.)

410.

RADAR CONTROL AND RADAR PLOT SCHEME—POLICY.

With reference to Navy Order 155 of 1945, columns 2 and 3 of table "D" are to be amended to read as follows:—

	Open to—	Special Qualifications.
R.C. 1 (Radar Control Rating 1st Class)	C.P.O., P.O. and L.S. R.C. 2. Exceptionally P.Os. or L.S. passed for P.O. either with or without a gunnery non-substantive rate.	(a) Recommended by C.O. (b) One year's service as R.C. 2 ashore or afloat. (c) A total of one year's service as R. C. 3 and/or R.C. 2, must have been served afloat. (d) If not R.C. must have had considerable experience in fire control, e.g., Senior rating in an HA/L.A.T.S., Rate Officer, etc. and have a high standard of intelligence.

(348/218/8.)

411.

H.M.S. "PEPYS"—COMMISSIONING.

H.M.S. *Pepys* (Royal Naval Base, Manus) was commissioned on 1st September, 1945.

(1804/4/53.)

By Authority: H. E. DAW, Government Printer, Melbourne.

RESTRICTED.(FOR OFFICIAL USE ONLY.)**Commonwealth Navy Order.**

Navy Office, Melbourne,
18th September, 1945.

The following Order, having been approved, is hereby promulgated for information and guidance and necessary action.

By direction of the Naval Board,

John Macarandell
Secretary.

*The Commodore Commanding H.M.A. Squadron,
and Commanding Officers of H.M.A. Ships,
Officers in Charge of H.M.A. Naval
Establishments, and others concerned.*

TABLE OF CONTENTS.

No. Subject.

412. Messages of Congratulations.

C.9286/45

412.

MESSAGES OF CONGRATULATION.

The following messages, received on the occasion of the surrender of the Japanese Empire, are promulgated for information:—

HIS MAJESTY THE KING.

“The surrender of Japan has brought to a victorious end the war which has engaged our full fighting strength all over the world. I send my heartfelt congratulations to the men and women of my Navies, Armies, and Air Forces throughout the British Commonwealth and Empire. Through the long years of the grim struggle with our enemies in the west and in the east, your unflinching resolution and indomitable courage in the face of manifold adversity have earned you the eternal gratitude of your countrymen. Many of your comrades have fallen in the fight; with you, I grieve for their loss, for the sufferings of the wounded and for the sorrows of the bereaved; with you I look forward to the safe homecoming of those who had to endure captivity. By God's mercy, the forces of evil have been overthrown, but many tasks remain to be accomplished if the full blessings of peace are to be restored to a suffering world. It is the duty of each one of us to ensure that your comrades have not died in vain and that your own hard won achievements are not lost to the cause of freedom, in which you undertook them. On behalf of all my peoples, I thank you. God bless you all. George R.I.”

HIS ROYAL HIGHNESS THE GOVERNOR-GENERAL.

“Please convey my heartiest congratulations to all personnel under your command on to-day's good news.”

THE SPEAKER, HOUSE OF REPRESENTATIVES, CANBERRA.

“In accordance with the direction of the House, I am transmitting to you hereunder the terms of a Resolution which was agreed to unanimously by the House of Representatives on Wednesday, 29th August, upon the motion of the Prime Minister, the Right Honourable J. B. Chifley:—

That the thanks of this House be accorded to the officers, warrant officers, petty officers and men of the Royal Australian Navy, for their heroic services in every theatre of war, for the guardianship of Australia from the attacks of our enemies, for the increasing vigilance in the patrol of many seas, for their courage and skill in convoying their soldier comrades and supplies to operational areas, and for the prestige they have won for their country wherever they have been.

That the thanks of the House be accorded to the officers, warrant officers, non-commissioned officers and men of the Australian Military Forces in the field for their courage and efficiency, their endurance in circumstances of unexampled hardship, for their magnificent achievements and for their undaunted spirit which has carried them through years of toil and suffering to complete victory.

That the thanks of this House be accorded to the officers, non-commissioned officers and men of the Royal Australian Air Force for their brilliant daring and conspicuous skill over land and sea, and for their calm courage and devotion to whatever dangerous and vital duties they have been allotted.

That the thanks of this House be offered to the men of the Merchant Navy, who carried out the vital task of keeping open the supply lines, always at great risk and imposing severe tests upon their endurance.

That the thanks of this House be accorded to the women of all the auxiliary services of the three arms of the fighting forces for their devotion and skill and solicitude for the sick and wounded of our sailors, soldiers and airmen.

That this House records its deep appreciation of the devotion and sacrifice of the fathers, mothers, wives and sisters of Australia's sailors, soldiers and airmen.

That this House records its deep appreciation of the efforts, money and gifts from the women, men and children of Australia to mitigate the hardships of Australian fighting men, to alleviate the lot of our prisoners of war and to make more comfortable the sick and wounded.

That the thanks of this House be offered to munitions and war workers generally in secondary and primary industries; to those men of 1914-18 who gave valuable home service in garrison and other work, and to the Volunteer Defence Corps.

That this House acknowledges with deep submission and reverence the heroism of those who have fallen in the service of their country, and tenders its sympathy to their relatives in the hour of their sorrow and their pride.

I desire to ask that you will be good enough to have the terms of the above resolution brought to the notice of all personnel referred to therein who come under your administration.”

THE BOARD OF ADMIRALTY.

“The surrender of the Japanese Empire brings to an end six years of achievement in war unsurpassed in the long history and high tradition of the Royal Navy.

2. The phase of Naval warfare which came to an end three months ago enriched the record of British sea power with such epic actions and campaigns as the Battle of the Atlantic, the domination of the Mediterranean, the maintenance of the Russian supply lines and the great combined operations of 1943 and 1944. The world wide story was completed with the inspired work by sea and air of the British Pacific Fleet and the East Indies Fleet. The Board are deeply conscious of the difficulty and novelty of the problems facing the British Pacific Fleet, the patience and skill with which they were overcome and the great contribution in offensive power made by the Task Forces operating with our American Allies. No less memorable is the work of the East Indies Fleet in the protection of India and Ceylon and in operational support for the Burma campaign.

3. At this moment, our eyes are turned to the Far East and it is fitting to recall in remembrance those who gave their lives in the days of disaster in 1941 and 1942. To their relatives and to the relatives of all officers and men of the Royal Navy and Royal Marines and of the Naval Forces of the Commonwealth and Empire and of all in Admiralty service who have paid the full price of victory, the Board extend their profound sympathy.

4. It is no small part of our thankfulness for this total defeat of the enemy that deliverance will come to those, naval and civilians, who were made prisoners of war by the Japanese and who have been subjected to great trials during the years of their captivity.

5. To the officers and men of the Royal Navy and Royal Marines and of the Naval Forces of the Commonwealth and Empire, the Board wish to express their congratulations, their gratitude, and their good wishes. They wish also to record their high appreciation of the contribution to the success of the Fleet made by the Auxiliary Services, the W.R.N.S., the Q.A.R.N.N.S., and the Civil Service in the employ of the Admiralty throughout the world.

6. It is the intention of the Board to proceed as rapidly as possible to the re-establishment of normal conditions. Officers and men and civil employees of the Admiralty will readily recognize, however, that the complicated work of six years cannot be simplified in a day and also that many commitments must be undertaken as a legacy of victory in two hemispheres. The new situation which now confronts us can only be dealt with successfully and speedily with the full co-operation and good will of all."

THE SUPREME COMMANDER OF THE ALLIED FORCES.

(a) "I have received the following inspiring message from His Majesty King George the Sixth of England and am proud and happy to forward it through you to the Forces:—

"I send you my heartfelt congratulations on overwhelming success which has crowned your efforts. From the first day of the treacherous attack on the Philippines up to this last glorious moment your Military skill, your dauntless courage and your inspiring leadership have gained universal admiration and esteem.

On behalf of all my people, I would ask you to convey a special message of thanks and congratulations to the Forces of the British Commonwealth who have had the honour to serve under your command in the series of operations now so brilliantly concluded'."

(b) "Australian soldiers, sailors and airmen :

Since the eighteenth of April, 1942, it has been my honour to command you in one of the bitterest struggles of recorded military history—a struggle against not only a fanatical enemy under the stimulus of early victory but the no less serious odds of seeming impenetrable barriers of nature—a struggle which saw our cause at its lowest ebb as the enemy hordes plunged forward with almost irresistible force to the very threshold of your homeland.

There, you took your stand and with your Allies turned the enemy advance on the Owen Stanleys and at Milne Bay in the fall of 1942, thus denying him access to Australia and otherwise shifting the tide of battle in our favour. Thereafter at Gona, Wau, Salamaua, Lae, Finschhafen, the Huon Peninsula, Madang, Alexishafen, Wewak, Tarakan, Brunei Bay, and Balikpapan your irresistible and remorseless attack continued.

Your airmen ranged the once enemy controlled skies and secured complete mastery over all who dared accept your challenge—your sailors boldly engaged the enemy wherever and whenever in contact in contemptuous disregard of odds and with no thought but to close battle so long as your ships remained afloat.

These, your glorious accomplishments, filled me with pride as your Commander, honoured for all time your flag, your people and your race, and contributed immeasurably to the advancement of the sacred cause for which we fought.

I shall shortly relinquish this Command which throughout its tenure you have so loyally and so gallantly supported. I shall do so with a full heart of admiration for your accomplishments and of a deep affection born of our long comradeship in arms.

To you of all ranks I bid farewell. MACARTHUR."

THE COMMANDER, 7TH FLEET.

"In relinquishing command of the Allied Naval Forces, S.W.P.A., I desire to express to my gallant officers and men who made the units of this Force my gratitude for their loyal devotion to duty and my admiration of their magnificent fighting spirit which made possible the performance of our assigned tasks. KINKAID."

THE COMMANDER-IN-CHIEF, BRITISH PACIFIC FLEET.

"Please accept my grateful thanks for the great welcome and material support which has always been accorded to the British Pacific Fleet by the Governments and peoples of Australia and New Zealand on whom we have been based."

THE PRIME MINISTER OF NEW ZEALAND.

"The Government and people of New Zealand extend to you and to the Chiefs of the Naval and Air Staff of Australia and all ranks under your command their warmest congratulations on the outstanding part played by all ranks of the Australian fighting forces to the victory we now enjoy. We recall the anxious days of the Japanese advance in New Guinea and in the waters north of the Continent halted by the gallantry and heroism of the men of the Australian fighting forces. These grim battles were the sure foundation upon which our victory has been built. We know that in peace as in war the armed forces of Australia and New Zealand will work together and that the imperishable traditions of Anzac will ever endure."

THE SPEAKER, LEGISLATIVE ASSEMBLY OF WESTERN AUSTRALIA (TO THE MINISTER FOR THE NAVY).

"The Legislative Assembly at its sitting yesterday passed the following resolution that the Legislative Assembly of Western Australia in Parliament assembled desires to convey the deepest thanks of the people of Western Australia to the fighting men of Australia for the magnificent service given by them in the cause of freedom, justice and righteousness. The deepest appreciation of our people is also expressed to all those men and women who assisted the fighting men by work and service in the various theatres of war on the seas, in the air or the home front."

THE SECRETARY, NAVY, ARMY AND AIR FORCE CLUB OF VICTORIA.

"I have great pleasure in advising you that, at the meeting of the Committee of this Club held on 23rd August, 1945, the following resolution was unanimously passed:—

'That the President and members of the Navy, Army, and Air Force Club of Victoria place on record their boundless admiration of the gallantry and high patriotism which all ranks of the Royal Australian Navy have shown during years which have called for the highest qualities of manhood.

That we forward to the First Member of the Naval Board our congratulations on the achievement of victory in Europe and the Pacific, and express our thanks and gratitude to all members of the R.A.N. whose courage and fortitude contributed to that victory.

That we record our deep sympathy with the comrades and relatives of those who died fearlessly in combat and pledge ourselves to do whatever individuals may do to see that their sacrifice will not have been in vain'."

2. The following messages were despatched:—

To HIS ROYAL HIGHNESS THE GOVERNOR-GENERAL.

"The Naval Board thank your Royal Highness for your gracious message which the Royal Australian Navy is honoured to receive.

We are proud to have shared in the triumph of sea power in the Pacific and are greatly heartened for the tasks ahead."

To COMMANDER 7TH FLEET.

For Admiral Kinkaid.

"The officers and men of the Royal Australian Navy were honoured to serve under your command in the Allied Naval Forces S.W.P.A. and on their behalf the Commonwealth Naval Board thanks you for your generous and inspiring message.

The Royal Australian Navy will always cherish the memory of our service in the Seventh Fleet and recall with pride and profound admiration our association with the gallant officers and men of the U.S. Navy in their many bold and resourceful operations in the defeat of Japan."

To THE SPEAKER, LEGISLATIVE ASSEMBLY OF WESTERN AUSTRALIA (FROM THE MINISTER FOR THE NAVY).

"Desire to thank all members of Legislative Assembly of Western Australia for resolution passed conveying the deepest thanks of the people of Western Australia to the fighting men of Australia for the magnificent service they have given. I shall be pleased to convey this resolution to the Government and members of the Royal Australian Navy."

To ALL R.A.N. SHIPS AND ESTABLISHMENTS.

"The Naval Board sends to the R.A.N. their warm appreciation of the fighting spirit, devotion to duty and cheerfulness which have been shown by all officers and men during nearly four years of intensive warfare against the Japanese enemy.

Sea power assisted by air power stemmed the Japanese advance which in 1942 threatened Australia. The relentless use of sea power has been largely responsible for destroying the enemy's power of aggression and desire to carry on the war, thus causing him to surrender. In this application of sea power, the R.A.N. has played its part with conspicuous efficiency, producing a record of which we can all feel justly proud.

The Naval Board wishes to express to all civilians of Administrative Staffs, Dockyards, Maintenance and Supply Depots and all Establishments in the Naval organization its warm appreciation of their splendid efforts during almost six years in the greatest war in history. As an integral part of the Naval Service, they have made an indispensable contribution to victory often in circumstances of the greatest urgency and pressure, and can feel justly proud of their fine record."

To ALL R.A.N. SHORE ESTABLISHMENTS.

"The Naval Board sends to the W.R.A.N.S. and R.A.N. Nursing Service their warm appreciation of the efficiency, cheerfulness and devotion to duty shown by all members during the years of warfare.

The achievements of the Women's Services have been a very definite contribution to victory and have excited the pride and admiration of all."

To PRIME MINISTER OF NEW ZEALAND.

"On behalf of all ranks of the R.A.N., I thank you most sincerely for your inspiring message which we are honoured to receive.

We would convey to you our admiration of the outstanding achievements of the R.N.Z. Navy in the war at sea and recall with pride our association in the Anzac Squadron in the anxious days of the Japanese attack."

3. The following statement by the Minister for the Navy is also promulgated for information:—

"Now that victory has come at last, it is fitting that we should pay tribute to the men of the Fighting Forces who have made that success possible, first by holding the enemy away from our shores, and then by carrying the war to the enemy's heart.

My own association with the Royal Australian Navy as its Minister dates from shortly before Japan commenced hostilities. Since then I have come to know many of its officers and men and to learn something of the difficulties under which they work. In the eyes of the Australian people, the prestige of the Royal Australian Navy stands at its highest level. It has carried out a task, many of the implications of which are not always apparent to the public and cannot always be translated into words.

Its task, in common with the Navies of the other United Nations, has been to keep the seaways of the world open to the Allies, and to deny the use of those seaways to the enemy. The world's greatest carrying vehicle is still the merchant ship, and it cannot carry troops, war materials, petrol and munitions to the battlefronts unless the world's oceans are kept open to it.

This policing of the seas is the basic function of a Navy in war, a function which has been faithfully discharged.

Numerically the smallest of the three Australian Services, the Royal Australian Navy has made the world its battlefield for almost six years. When Germany surrendered, the Admiralty recorded their sincere appreciation of the Royal Australian Navy's very valuable services in the war at sea. As it is Sea Power, fundamentally, which has brought Japan to her knees, and as our own Navy has played its part with the Allies in implementing that power against Japan, we can justly echo that message of congratulation.

This work has not been accomplished without loss. Since the war began, the Royal Australian Navy has suffered 2,948 casualties, including 1,327 killed, died of wounds, or missing presumed dead. Prisoners of war in Japanese hands total 249. Through enemy action we have lost three Cruisers, four Destroyers, two Sloops, one Corvette, a Depot Ship, and two miscellaneous craft—apart from losses by maritime hazards.

As we celebrate the victory, let us not forget those men who gave their lives that we might see this day, and the relatives and friends who are left to mourn them.

All Australia will join me in honouring their memory, and in paying tribute to the officers and men who have come safely through the years of war. With that tribute we must link the personnel of the Women's Royal Australian Naval Service and of the Royal Australian Naval Nursing Service.

It must be borne in mind that unlike the other Services, a not inconsiderable Section of the Naval Organization comprises civilian officers and employees of all grades, taking a most important and active part behind the fighting Ships, maintaining them in an efficient condition and supplying the necessary stores, food, and munitions.

I am personally aware of the loyalty and hard work of the whole of the civil side of my Department, from the Senior Administrative Officers down, often under difficult circumstances and working against time. They have not spared themselves in their service to the Government.

The whole-hearted co-operation of both uniformed and civilian sections of the Navy has undoubtedly greatly contributed to the prestige of the Royal Australian Navy."

(443/202/291.)

(This Order will be reprinted for posting on Notice Board.)

RESTRICTED.

(FOR OFFICIAL USE ONLY.)

Commonwealth Navy Order.

Navy Office, Melbourne,
25th September, 1945.

The following Order, having been approved, is hereby promulgated for information and guidance, and necessary action.

By direction of the Naval Board,

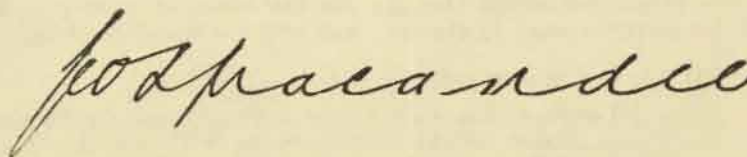

Secretary.

*The Commodore Commanding H.M.A. Squadron,
and Commanding Officers of H.M.A. Ships,
Officers in Charge of H.M.A. Naval
Establishments, and others concerned.*

TABLE OF CONTENTS.

No.	Subject.
413.	Procedure for dealing with Naval Stores in Vessels Being Paid Off under the Demobilization Scheme.
C.9404/45.	

413.

**PROCEDURE FOR DEALING WITH NAVAL STORES IN VESSELS
BEING PAID OFF UNDER THE DEMOBILIZATION SCHEME.**

The following instructions are to be observed in connection with the paying off and destoring of ships at the various ports. Whilst these instructions refer to documents which in some instances are only in use in centrally stored ships the principles and procedure are applicable to all ships subject to modification in regard to detailed procedure and vouchers as determined by the particular storekeeping system in force.

2. At each port the Naval Officer in Charge should arrange a conference of the following Officers to determine a general programme for the paying off, return of Naval Stores, &c. :—

Naval Officer in Charge or representative.

(Superintending) Naval Store Officer and other Dockyard Officers as requisite.

Base Supply Officer.

Base Engineer Officer.

Commanding Officers and Supply Officers of ships concerned.

Officers to be responsible for ships or groups of ships whilst in reserve.

3. In each ship the Commanding Officer should confer with the ship's Supply Officer and ship's Officers holding items on loan to arrange a planned programme within the ship for the return of stores from loan, their temporary stowage in the ship, and ultimate return to store.

(1) *The Commanding Officer should—*

- (a) arrange that each Officer holding stores on Permanent Loan has his list compared with the Storekeeping Officer's *standard* copy to ensure that the remains shown in the Departmental copy agree with the Storekeeping Officer's copy which is the official list, musters his stores, and reports in writing any differences. On receipt of a report of differences action in accordance with the relative regulations should be taken (B.R. 4, Chapter XII., Instructions for Supply, Accounting, &c., for Naval Stores in Merchant Vessels commissioned for Naval Service; Commonwealth Navy Order 632 of 1943).
- (b) Ensure that before an Officer leaves the ship the stores on his charge have been either returned to the Storekeeping Officer or transferred to another Officer.
- (c) It will not be practicable in most cases for all the portable stores returned from Permanent Loan to be stowed in the ship's storerooms and the Commanding Officer should arrange for other suitable lock-up stowage, i.e., spare cabins &c., as may be necessary to be made available to the Storekeeping Officer to ensure the safety of the stores whilst they are in the ship awaiting return to the shore store.

(2) *Officers holding Stores on Loan are to—*

- (a) arrange for comparison of their copies of Permanent Loan Lists with the standard copy held by the Storekeeping Officer, muster the stores in their charge and after investigation report in writing to the Commanding Officer any differences.
- (b) Ensure that their reliefs or other Officers take over and sign for any stores remaining in their custody on the date of their departure from the ship.

(3) *Storekeeping Officers are to—*

- (a) Organize a programme for the ordered return of the stores on Permanent Loan to the extent necessary and practicable to their custody, and their safe stowage pending return to the shore store.
- (b) Arrange to clear the Permanent Loan Lists and the Naval Store Ledgers as the various items on Permanent Loan are returned by Officers concerned.
- (c) Ensure that as each Officer leaves the ship a receipt for any items remaining on the Permanent Loan List concerned is signed by another Officer.
- (d) As soon as the date of paying off is known, put in hand as much preliminary work as possible so that the considerable amount of work involved is spread over the full period available. For instance an immediate start can be made in preparing forms A.S. 331 in ships which are to destore on paying off. As the first step these should be prepared for all items stocks of which are in the ship's Naval Store. The pattern numbers and descriptions only (not quantities) should in the first instance be written up on the forms A.S. 331 direct from the ledgers. Later when the stores are to be returned to the shore Naval store the quantities as per actual physical check are to be inserted on the forms A.S. 331 before the items are removed from the ship's store.
- (e) In the case of items returned from Permanent Loan, stores common to various Departments can be placed in the Naval Store and their return dealt with when return of similar items from Naval Store stocks is arranged. For the balance of the loose items returned from Permanent Loan it may be more convenient for the A.S. 331 to be prepared from each A.S. 1091 concerned. All A.S. 1091's for items returned from Permanent Loan are to be attached by the Stores staff to the pertinent Storekeeping Officer's copies of the Permanent Loan Lists but *need not be posted in the store ledgers* which may be cleared direct from properly receipted quadruplicate copies of forms A.S. 331.

(f) Review tools and other Naval Stores on temporary loan and arrange for early return to the store of items which will not be required.

(g) Arrange for unused stocks of Consumable stores held by ships Officers outside the Naval storeroom to be returned to the Naval Store on forms A.S. 1091.

4. Particular attention is drawn to the fact that all valuable portable items, e.g., clocks and watches, telescopes, binoculars, &c., not required to be retained on board should be returned separately to the (Superintending) Naval Store Officer or Base Supply Officer. Such items are not to be placed with or returned with other stores but are to be taken personally to the store concerned and a receipt obtained for them on the spot. In order to guard against the possibility of loss they should not be retained in the ship longer than is necessary.

5. The return of Naval stores from ships being paid off and destored should be dealt with generally in two phases. In the first phase all stocks of Naval stores normally held in storerooms together with all portable items should be returned. Fitted equipment and bulky items such as furniture, &c., should not normally be dealt with until the return of easily portable items has been satisfactorily finalized in order that confusion may be avoided and bearing in mind that fitted and bulky items are not subject to loss to the same extent as are the smaller portable items.

6. It is pointed out that in the case of M/Ls. and other small vessels to which the provisions of Navy Order 632 of 1943 are applicable the Storekeeping Officer of the parent ship or Base is the Storekeeping Officer of the M/L. &c., and in such vessels the Commanding Officer stands in much the same relation to the Storekeeping Officer as does the Head of a Department in a larger ship to the Storekeeping or Supply Officer.

7. All Officers who hold Naval stores on temporary loan, on Permanent Loan, or as Storekeeping Officers are informed that they are responsible for such stores until that responsibility is assumed by another Officer and it is their responsibility to see that when giving up charge, finally leaving the ship, &c., the stores are turned over to their reliefs or other Officers. In the case of stores returned to ships' storerooms or to shore stores, Officers are to ensure that they obtain proper receipts for all items parted with.

8. The work devolving on ships' Storekeeping Officers and staffs and on shore Store staffs will be very heavy and the Naval Board expect other Officers to assist to the extent practicable in facilitating their work. In particular the following will help—

(i) When it is known that a ship is to pay off and destore application for replacement of unserviceable permanent items should not be made unless it is known they will be required. Demands to replenish the stock of Consumable Stores should be kept to a minimum.

(ii) Any unused Consumable stores in ready use storerooms under control of ship's Officers should be used up in lieu of drawing further items from the ship's Naval Store.

(iii) Demands on the Naval store by departments of the ship should be limited to essential requirements for use, and the hours during which the Naval Store is open for normal issues should be strictly limited to permit the Stores staff as much opportunity as possible to progress, without undue interruption, the large amount of work they are required to undertake. Stores staff should be given such assistance as is possible to facilitate their work.

(iv) It is the responsibility of Officers holding stores on Permanent loan to muster their own stores and Store staff should not be called on to assist unless the circumstances are exceptional.

9. The Base Supply Officer of the port or other Supply Officer specially appointed for the purpose will be generally responsible for ensuring compliance with the paying off instructions applicable to the ship's paying off in the port insofar as the return of stores, closing of accounts, &c., are concerned. Local arrangements are to be made at each port for the Base Supply Officer to be notified in advance of the date on which each Storekeeping Officer or Departmental Officer of a ship holding Naval Stores on Permanent Loan is due to leave the ship and on receipt of this information he is to take steps to ensure that all necessary action by those Officers has been properly finalized. He is to report specially to the Officer-in-Charge of Reserve ships and the Naval Officer-in-Charge any cases where the Naval Store Accounts are unsatisfactory or where serious losses, &c., have occurred.

Inspecting Officers attached to the staff of the Director of Naval Stores will be allocated to each port to advise Base Supply Officers and ships' Storekeeping Officers in connection with destoring procedure, closing of accounts, &c.

10. On completion of paying off Naval Stores remaining on board together with the Naval Store accounts or Inventories of ships concerned will be the responsibility of the Officers appointed for the purpose.

11. A summary of action to be taken in vessels paying off under the several categories mentioned is appended.

SUMMARY.

The instructions in C.O.R. Articles 414 and 415 will, subject to the following, govern generally the procedure to be followed. Variations considered desirable by Naval Officers-in-Charge to these Instructions should be submitted for the approval of the Naval Board.

Note.—References to Dockyard Officers at ports other than Sydney apply to the appropriate Dockyard or Base Officers.

(1) *Vessels paid off into reserve at Standard Notice.*

The instructions in Appendix XXIV., Section 1, of B.R. 4 will be applicable. The vessels will not be destored and the Naval Store Accounts will remain open.

(2) *Vessels to be Dismantled and Sunk.*

The provisions of C.O.R. Articles 414 and 415 will apply—see also Appendix XXIV., Section 2, of B.R. 4. All Radio Equipment is to be treated as for W/T. After return of all Naval Stores, other than those necessarily retained in the ship, inventories of items remaining on

board are to be prepared in accordance with the relevant regulations. The Naval Store Accounts are to be finally closed and forwarded with all supporting vouchers to the Director of Naval Stores, Navy Office, Melbourne, under cover of a letter of advice signed by the Storekeeping Officer, showing particulars of the closed ledgers, permanent loan lists and packages of vouchers, &c., concerned.

(3) *Vessels to be paid off into Reserve at Extended Notice, for Disposal, &c.*—

- (a) *A.M.S. Vessels and other ships built as war vessels, to be paid off into "F" Class Reserve, i.e., at extended notice for care and maintenance.*—The provisions of C.O.R. Articles 414 and 415 will be applicable—see also Appendix XXIV., Section 2, of B.R. 4—except that in the case of Radio Equipment sub-paragraphs (b) and (c) hereunder are to be complied with and, in the case of A/S. and E/S. Gear, Appendices "A" and "B" of this Order are to be observed. These vessels are to be destored and items remaining on board shown in Inventories in accordance with the appropriate regulations. The Naval Store Accounts are to be closed and together with all supporting vouchers forwarded to the undermentioned Officers under cover of a letter of advice signed by the Storekeeping Officer showing particulars of the closed ledgers, permanent loan lists and packages of vouchers, &c., concerned:—

Vessels paid off at—

Melbourne ..	Director of Naval Stores.
Sydney ..	Suptg. Naval Store Officer, Sydney.
Brisbane ..	Naval Store Officer, Brisbane.
Fremantle ..	Naval Store Officer, Fremantle.

- (b) In the case of ships smaller than A.M.S. all Radio (including Radar) Equipment should be removed and returned to Store.
- (c) In A.M.S. and above where the vessels are not paying off to be dismantled and sunk the fitted Radio Equipment will in general be retained on board. In such cases:—
- (i) Any remote Radar Display Unit (such as a P.P.I.) fitted on a compass platform or other exposed position, is to be removed together with its case and placed in the Radar office of the set to which it belongs. This also applies to units of W/T. equipment fitted in exposed positions.
- (ii) The reflector and horn of the Radar type A276 aerial are to be removed and placed in the A276 office and a waterproof canvas cover fitted over the remaining portions of the aerial. The wave-guide opening revealed by the removal of the aerial horn should be covered with a blank metal or wooden plate. Aerials of gunnery Radar sets should also be fitted with a waterproof canvas cover.

(iii) Offices housing Radio equipment (W/T. and Radar, &c.) are to be locked. Where a set is installed in a chart room or items of equipment are situated in any other office or plotting position, such room or plotting position should be locked, otherwise equipment should be removed and placed in the office of the set to which it belongs, or in the case of a set situated in an office which cannot be locked, the panels of this set should be removed and placed in one of the other Radar or W/T. offices.

(iv) In the case of Radar sets with the transmitter situated in a lobby or passageway, the unit should be locked, and in cases where no lock is provided, one should be fitted.

(v) All ventilating trunks, &c., open to the weather should be closed.

(d) *Auxiliary Vessels.*—These will generally fall under two categories, viz.:—

(i) Those owned by the Navy.

(ii) Those on hire which require to be returned to the Owners.

In the case of Navy owned vessels the procedure (except for Radio Equipment, A/S. and E/S. Gear) applicable to ships at extended notice should be generally followed but the vessels should be destored only to the extent that this is necessary to ensure safe custody of the stores and equipment. The instructions in paragraphs (a), (b) and (c) above apply to comparable Auxiliary vessels. In the case of vessels on hire and paid off for return to their owners the procedure outlined in Navy Order 574 of 1943 should be observed. Special precautions should be taken by the local Naval Officers-in-Charge to ensure that all stores on board are in safe custody during any period between the date of paying off the vessel and the date of turnover to the Owners.

Note.—Radio equipment is taken to include W/T., R/T., Radar, D/F., Loran, R.C.M., &c., together with associated aerials, remote display or control units, power supplies, &c. S.R.E. equipment when on charge as a Naval Store item is to be regarded as Radio equipment.

12. The principles of this Order are also applicable to Shore Establishments and Services being closed down.

APPENDIX "A".

Where these instructions in regard to A/S. and E/S. Gear are in conflict with C.O.R. the latter will be inapplicable.

I. A/S. EQUIPMENT.

(i) Dome to be left shipped in the housed position and should not be pumped out except when docking or for the purpose of periodically changing water.

(ii) Oscillator to be unshipped and returned in transport box to nearest Naval Store.

Type 128—Blank cover plate to be fitted.

Type 134—Tube inner, tube intermediate and strut streamline to be removed from directing gear assembly and returned to store. Top of directing gear assembly to be blanked off with plate blanking.

(iii) Mechanical gear to be well greased. All bared electrical leads to be taped to prevent ingress of moisture.

(iv) Batteries—All dry cells (Patts. 2951, 14001, 3773, 3774) to be withdrawn from installation. Accumulator—if serviceable or after economical repair, to be returned to store for issue as required and if so issued others supplied to ship in lieu on recommissioning.

(v) Motor alternators (high and low frequency) and lifting motor to be removed and returned to store.

(vi) Instruments in exposed positions (Bridge recorder, loud speaker, bearing plotter) to be detached and stowed in instrument space.

(vii) Stylus guide bars and springs or recorders to be oiled, time to fire mechanism to be greased.

(viii) A/S. Hut, Instrument space and Directing Gear compartment to be kept locked.

II. E/S. EQUIPMENT.

(i) Hull tanks to be topped with fresh water. Gravity feed system to be removed and tanks sealed in accordance with B.R. 638 (Handbook of E/S. Set Type 758) Chap. 11, paragraph 6.

In cases of ships fitted with Type 766 the portable transceiver unit is to be removed and stowed inboard.

(ii) Batteries—All dry cells (Patts. 2951, 14001, 3773) to be withdrawn from installation. Accumulators—if serviceable or after economical repair to be returned to store for issue as required and if so issued others supplied to ship in lieu on recommissioning.

(iii) Instruments in exposed positions (Recorders, Amplifiers Boards Charge/discharge) to be detached and stowed in A/S. Instrument space or other locked compartment.

(iv) Sliprings, tank face and mechanical parts of Recorder to be lightly coated with vaseline.

III. Detailed instructions in regard to certain ships are shown in Appendix "B".

APPENDIX "B".

DISPOSAL OF A/S., E/S. AND LISA EQUIPMENT IN VESSELS PAYING OFF.

Paying Off Port.	Ship.	Gear to be Removed.	Removal By.	Docking or Shipping Required.
Sydney ..	<i>Adelaide</i> ..	A/S—Directing Gear Patt. A. 810 E/S—All electrical gear including oscillators negative tanks	Base A/S Staff and Dockyard	Yes
Sydney ..	<i>Vendetta</i> .. <i>Doomba</i> ..	A/S—All electrical gear, dome, oscillator and all removable fittings from directing gear compartment. E/S*—All electrical gear including oscillators negative tanks	Ship's Staff Base A/S Staff	No
Sydney ..	A.M.S. Vessels	A/S—Oscillator, batteries, motor alternators, lifting motor. Routine for placing remaining A/S and E/S gear in maintenance reserve as per Appendix "A"	Ship's Staff. Base A/S Staff	No
Sydney ..	<i>Bangalow</i> .. <i>Polaris</i> .. <i>Innisfail</i> .. <i>Limosa</i> ..	E/S—All electrical gear including oscillators	Ship's Staff. Base Staff	No
Sydney ..	M.L's (7) .. H.D.M.L's (6)	E/S— <i>Vide</i> Item 5 (i) (i) To "F" Class reserve for C. and M. A/S—All electrical gear. Directing gear <i>vide</i> Appendix "A", para. 1 (ii) E/S—All electrical gear including oscillators negative tanks	Ship's Staff	No
Sydney ..	<i>Gunbar</i> .. <i>Kurama</i> .. A.M.S. Vessels	LISA—Complete set (ii) To "F" Class reserve for disposal or A/S, E/S and LISA fitting.	Ship's Staff, Base A/S Staff, and Dockyard	Yes
Fremantle Fremantle	<i>Kybra</i> .. A.M.S. Vessels	A/S—Complete set, type 135 .. <i>Vide</i> para. 3	Base A/S Staff <i>Vide</i> para. 3	No No
Fremantle	<i>Limicola</i> .. M.L's (6) .. H.D.M.L's (6)	A/S—Types 127 and 128. All electrical gear oscillators and removable fittings from directing gear compartment. Directing gears to be removed on slipway, holes in hull to be filled in. LISA—Converter and transformer. E/S—Complete set, type 761.	Ship's Staff, Base A/S Staff, and Dockyard	Yes
Melbourne Adelaide Brisbane	A.M.S. Vessels <i>Yandra</i> .. M.L's (16) .. H.D.M.L's (12)	<i>Vide</i> para. 5 (i) <i>Vide</i> para. 5	<i>Vide</i> para. 5	<i>Vide</i> para. 5
Darwin ..	<i>Larus</i> .. <i>Koompartoo</i> ..	<i>Vide</i> para. 3 <i>Vide</i> para. 8 <i>Vide</i> para. 5	<i>Vide</i> para. 3 <i>Vide</i> para. 8 <i>Vide</i> para. 5	No Yes <i>Vide</i> para. 5
		<i>Vide</i> para. 5 (i) <i>Vide</i> para. 6	<i>Vide</i> para. 6	No

* *Vendetta* only.

RESTRICTED.

(FOR OFFICIAL USE ONLY.)

Commonwealth Navy Order.

Navy Office. Melbourne,
25th September, 1945.

The following Order, having been approved, is hereby promulgated for information and guidance, and necessary action.

By direction of the Naval Board,

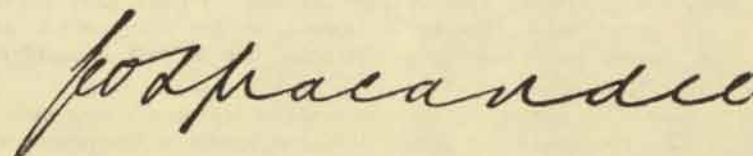

Secretary.

*The Commodore Commanding H.M.A. Squadron,
and Commanding Officers of H.M.A. Ships,
Officers in Charge of H.M.A. Naval
Establishments, and others concerned.*

TABLE OF CONTENTS.

No.	Subject.
414.	Depth Charges—Care and Maintenance.

C.9408/45.

414.

DEPTH CHARGES—CARE AND MAINTENANCE.

Reports received from ships indicate that the regulations for care and maintenance of depth charge equipment in many Frigates, A.M.S. vessels and M.L.'s are not being carried out.

2. In several cases, failures of depth charges to fire have been due to bad drill.

3. Frequent visits should be made to vessels by Base Torpedo and A.S. Officers to ensure that the instructions for care and maintenance are being carried out. Instructions and drill should be given by Base Staff where found necessary.

4. Commanding Officers of ships visiting a port where Base Torpedo and A/S Officers are borne should avail themselves of the services of these officers for instruction in care and maintenance of depth charge equipment and in depth charge drill.

5. The most common faults that occur in the preparation of depth charges for service are :—

- (a) *Fitting of Pistols.*—Detonator carrier screwed up only hand taut to the pistol body. This gives deep firing and, in the worst cases, complete failure. The detonator carrier should be screwed tightly to the pistol body using two spanners, St. No. 6213. (C.B. 4257 (6) para. 64.)
- (b) *Priming.*—Primer loose or only screwed up hand taut in the primer tube. This is the cause of shallow firing, which may easily cause damage to the firing ship as well as nullifying the attack.

The primer should be inserted in the primer tube until it bears against the pistol, when the handle of the primer will protrude approximately $\frac{3}{4}$ in. from the end of the primer tube. The slotted end of the primer locking tool, St. No. 6177, should be engaged with the split pin on the stopper spindle to prevent rotation of the primer. The handle should then be turned to expand the rubber ring, which should be finally screwed up taut by inserting the tool in the handle.

The importance of screwing up taut cannot be over emphasized. (C.B. 4257 (6) para. 68.)

A watertight joint between pistol and primer tube is equally important. Spanner box, St. No. 6825, should be used with a samson to increase the leverage when screwing up the pistol securing nut.

- (c) *Lubrication of Pistols.*—Too much grease has been used on pistols. A very thin film of grease should be applied by dipping the finger in the grease and then running it over the parts concerned. (C.B. 4257 (7) para. 73.)
- (d) *Primer Gauge.*—The primer gauge should always be used after fitting pistols. (C.B. 4257 (6) para. 66.)

6. Plugs, wood primer tube, St. No. 6053, and bolts complete with nuts and washers, St. No. 6012, are always to be supplied with the charge and are to be retained on board. The plugs complete with bolts and washers are always to be fitted when depth charges are landed or transported. Wood plugs and associated stores remaining on board from expended depth charges should be returned to the nearest armament depot at the first opportunity.

When depth charges are unfitted or unprimed, the primer tube should be closed by means of these plugs to prevent the entry of water and foreign matter.

Demands to make good any deficiencies of plugs, &c., should be forwarded to the nearest armament depot.

7. Practice Expenditure.—

- (a) Ships fitted with depth charge throwers are to fire for practice one full pattern of depth charges every six months.
- (b) Ships fitted with chutes only are to expend for practice one depth charge every quarter.
- (c) Ships and patrol craft in full commission carrying depth charges (M) are to expend one D.C. (M) each quarter.
- (d) Opportunity should be taken by ships and depots during the above practices to expend any depth charges with split welds, obliterated markings or other defects which will not affect the functioning of the fitted depth charge.
- (e) Attention is drawn to C.B. 4257 (1), para. 39, re minimum speeds when dropping depth charge patterns.

Minimum speeds and settings for M.L. (Fairmiles) are as follows (C.B. 4257 (1) para. 39, Table III.)

Ship.	Minimum Speed.		Minimum Depth Setting.
	Amatol.	Minol.	
M.L. (Fairmile)	14 kts.	16 kts.	50 feet
	7½ ..	10½ ..	100 ..
	6 ..	6 ..	150 ..

8. *Depth Charges with Split Welds.*—Whenever depth charges have to be dumped due to split welds or other causes, a report should be forwarded to the Director of Ordnance, Torpedoes and Mines, Navy Office, giving the number of the depth charge, filler initials, date of filling, particulars of filling, date received on board and whence received.

Care should be taken to dump the charges in **deep water**.

9. History Sheets are to be disposed of as follows:—

	<i>Disposal of History Sheet.</i>	<i>Disposal of Depth Adjuster Key.</i>
Depth charge pistols expended in action or practice which have functioned correctly.	Forward to Director of Ordnance, Torpedo and Mines, Navy Office, Melbourne.	Return in box to nearest Armament Depot.
D.C. pistols jettisoned, lost overboard or otherwise expended.	To accompany report of circumstances of expenditure to the Administrative Authority.	Return in pistol box to nearest Armament Depot.
D.C. pistols expended in depth charges which have failed to detonate.	To accompany report of failure to the Administrative Authority.	To accompany report of failure to the Administrative Authority.

History sheets are important documents and should be filled in and despatched without delay.

(b) Depth adjuster keys are not required at Navy Office, and after being sighted by the Administrative Authority they should be returned to the nearest armament depot.

(c) The report rendered by the Administrative Authority should state that the depth adjuster key has been sighted.

(d) When filling in history sheets, the following additional information should also be included: Mark, lot No. and filler's initials of both primer and detonator.

10. *Depth Charges.*—(a) Slightly rusted depth charges should be cleaned and repainted, taking care not to paint over explosive markings. Those badly rusted should be used for practice, or returned to the nearest armament depot, as to scrape them on board may be dangerous.

(b) Primer tube.—Rust in the primer tube should be cleaned off and the surface given two coats of varnish with a soft, clean brush, the first coat being allowed to dry hard before applying the second.

The varnish should be made up of—

Shellac varnish	1 pint.
Graphite	6 oz. by weight.

(c) In hot climates, depth charges should be sheltered from the direct rays of the sun as much as practicable by canvas covers, screens or other suitable means to obviate the possible fracture of the welding due to expansion of the explosive charge.

11. The following is a summary of routines to be carried out in M.L.'s and coastal craft.

Depth Charges.—

	<i>Routine.</i>	<i>Carried out by.</i>
(a) <i>On receipt</i> —		
(i)	Check that the filling bungs are tight and, if necessary, break seal and tighten hard up	Base staff.
(ii)	Inspect and, if necessary, clean and paint. (See para. 10)	Ship's staff.
(b) <i>Weekly</i> —	Turn depth charges in exposed positions through 90°	Ship's staff.
(c) <i>Monthly</i> —	When pistols are removed from depth charges on the upper deck, inspect the primer tube and carry out the routine laid down in para. 10 (b)	Ship's staff.
(d) <i>Quarterly</i> —	Carry out the routine on receipt	Base staff and ship's staff.
(e) <i>Yearly</i> —	Return all depth charges to the nearest armament depot for inspection	Ship's staff.

12. *Primers*—

(a) <i>Weekly</i> —	Move the primer from end to end in the primer tube. In tropical temperatures, French chalk is to be liberally applied to the I.R. ring	Ship's staff.
(b) <i>Quarterly and After Heavy Weather</i> —	Remove the primer from the primer tube. Clean and apply a drop of oil to the threads if necessary. Check that the rubber expands when the handle is screwed up. Replace	Ship's staff.

13. *Pistols*—

(a) Monthly	} <i>Vide</i> C.B. 4257 (7) para. 52	} Base staff.
(b) Quarterly		
(c) Six monthly		
(d) Yearly		

14. *Depth Charge Chutes*—

(a) <i>Daily</i> —	Fit harbour lashings and test release gear ..	Ship's staff.
(b) <i>Weekly</i> —		
(i)	Examine slings and lashings, renew as necessary	Ship's staff.
(ii)	Examine release gear, grease as necessary
(c) <i>Yearly</i> —		
(i)	Test slings	Dockyard
(ii)	Test davits and all lifting appliances

<i>Routine.</i>	<i>Carried out by.</i>
15. "Y" Gun—	
(a) <i>Daily</i> —	
Check that carriers are free to turn and free to move in and out	Ship's staff.
(b) <i>Weekly</i> —	
(i) Unship firing mechanism, remove impulse cartridge, examine and work firing mechanism, lightly oil with mineral oil, and replace	Ship's staff.
(ii) Unload charges and carriers. Clean and lightly grease carriers.	
(iii) Lightly grease spare carriers.	
(iv) Clean and sponge out barrels. Great care must be taken to keep barrels dry since no drain holes are fitted.	
(c) <i>Quarterly</i> —	
(i) Dismantle and clean firing mechanism	Base staff.
(ii) Measure protrusion and strength of blow of striker.	
(iii) Examine and tighten holding-down bolts.	
(d) <i>Yearly</i> —	
Remove, examine and renew holding-down bolts as necessary	Base staff.
(e) <i>Three-yearly and after 50 Rounds</i> —	
Inspect barrel, explosive chamber and firing gear as laid down on Form O.211 "Memorandum of Inspection"	N.A.S.O.

16. Navy Orders 75, 149, 162, and 421 of 1943, 145 and 165 of 1944, and Confidential Commonwealth Navy Order 122 of 1944 are hereby cancelled.

(471/205/2684.)

RESTRICTED.(FOR OFFICIAL USE ONLY.)**Commonwealth Navy Orders.**

Navy Office, Melbourne,
25th September, 1945.

The following Orders, having been approved, are hereby promulgated for information and guidance and necessary action.

By direction of the Naval Board,

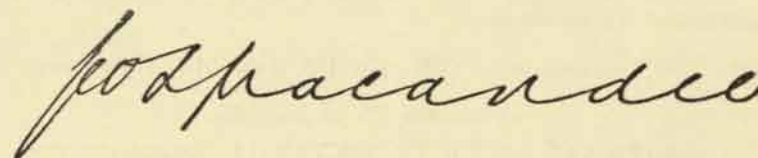

Secretary.

*The Commodore Commanding H.M.A. Squadron,
and Commanding Officers of H.M.A. Ships,
Officers in Charge of H.M.A. Naval
Establishments, and others concerned.*

TABLE OF CONTENTS.

No.	Subject.
415.	H.M.A.S. "Koorine"—Paying off.
416.	H.M.A.S. "Mischief"—Paying off.
417.	Orders under National Security Regulations.
418.	Controller of Naval Demobilization.
419.	Transfer—N.A.P. to R.A.N.V.R.—Certificates of Service.
420.	Bursaries for Children of Personnel Killed or Disabled During the Present War.
421.	Girl Guides' Holiday Gift to the R.A.N. Patriotic Fund of Victoria.
422.	Vacancies in Repatriation Department.
423.	Carrier's Ammunition Quadruple Q.F. 4-in.—Modification.
424.	Accounting for Naval Stores incorporated in W/T., A/S., Radar, &c., Sets.
425.	Wooden Folding Camp Stretchers—Replacement.
426.	Demands for Dry Provisions in Darwin, New Guinea and Moluccas Areas.
427.	Concentrated Hardened Butter—Use of, by Small Ships.
428.	Economy in the Use of Stationery.
429.	Demobilization Forms.
430.	Form A.S. 5—Cash Advances or Transfers—Voucher Reference to be Quoted on Form A.S. 5.
431.	Books and Forms.

415.

H.M.A.S. "KOORINE"—PAYING OFF.

H.M.A.S. *Koorine* was paid off on 4th September, 1945.
(603/246/5351.)

416.

H.M.A.S. "MISCHIEF"—PAYING OFF.

H.M.A.S. *Mischief* was paid off on 7th September, 1945.
(603/246/5360.)

417.

ORDERS UNDER NATIONAL SECURITY REGULATIONS.

The following Orders under National Security Regulations are hereby promulgated for information :—

(a) *Commonwealth Gazette*, No. 168, dated 31st August, 1945.

Commonwealth of Australia.

**NATIONAL SECURITY (GENERAL) REGULATIONS.
ORDER UNDER REGULATION 17AB.**

In pursuance of regulation 17AB of the National Security (General) Regulations, I, Norman John Oswald Makin, Minister of State for the Navy, hereby make the following Order :—

I hereby revoke the Control of Hydrographical Publications Order, dated 9th March, 1942, and published in the *Gazette* on 23rd March, 1942, as amended by Order, dated 13th July, 1942, and published in the *Gazette* on 30th July, 1942.

Dated this twenty-third day of August, 1945.

NORMAN MAKIN,

Minister of State for the Navy.

(b) *Commonwealth Gazette*, No. 173, dated 7th September, 1945.

Commonwealth of Australia.

**NATIONAL SECURITY (GENERAL) REGULATIONS.
ORDER UNDER REGULATION 45.**

In pursuance of regulation 45 of the National Security (General) Regulations and Instrument of Delegation, dated the twentieth day of August, 1945, I, Henry Arthur Showers, the officer performing the duties of Chief of Naval Staff, hereby make the following Order :—

I hereby revoke the Navigation (Port Stephens—Private Craft) Order, dated 9th December, 1942, and published in the *Gazette* on 17th December, 1942.

Dated this twenty-eighth day of August, 1945.

H. A. SHOWERS,

The Officer Performing the Duties
of Chief of Naval Staff.

(c) *Commonwealth Gazette*, No. 173, dated 7th September, 1945.

Commonwealth of Australia.

**NATIONAL SECURITY (GENERAL) REGULATIONS.
ORDER UNDER REGULATION 45.**

In pursuance of regulation 45 of the National Security (General) Regulations and Instrument of Delegation dated the twentieth day of August, 1945, I, Henry Arthur Showers, the officer performing the duties of Chief of Naval Staff, hereby make the following Order :—

I hereby revoke the Navigation (Brisbane River and Moreton Bay—Small Craft) Order, dated 14th November, 1942, and published in the *Gazette* on 23rd November, 1942, as amended by the Navigation (Brisbane River and Moreton Bay—Small Craft) Order (No. 2), dated 6th January, 1945, and published in the *Gazette* on 15th January, 1945.

Dated this twenty-eighth day of August, 1945.

H. A. SHOWERS,

The Officer Performing the Duties
of Chief of Naval Staff.

(d) *Commonwealth Gazette*, No. 173, dated 7th September, 1945.

Commonwealth of Australia.

**NATIONAL SECURITY (GENERAL) REGULATIONS.
IMMOBILIZATION OF VESSELS ORDER REVOCATION ORDER.**

In pursuance of regulation 45D of the National Security (General) Regulations and Instrument of Delegation dated the twentieth day of August, 1945, I, Henry Arthur Showers, the officer performing the duties of Chief of Naval Staff, hereby make the following Order :—

CITATION.

1. This Order may be cited as the Immobilization of Vessels Order Revocation Order.

Revocation of Immobilization of Vessels Order and Amending Orders.

2. The Orders specified in the Schedule to this Order are hereby revoked.

THE SCHEDULE.

Immobilization of Vessels Order, dated the tenth day of March, 1942, and published in the *Gazette* on the seventeenth day of March, 1942.

Immobilization of Vessels Order (No. 2), dated the thirteenth day of March, 1942, and published in the *Gazette* on the twenty-third day of March 1942.

Immobilization of Vessels Order (No. 3), dated the eighteenth day of August, 1944, and published in the *Gazette* on the twenty-fifth day of August, 1944.

Dated this twenty-eighth day of August, 1945.

H. A. SHOWERS,

The Officer Performing the Duties
of Chief of Naval Staff.

(e) *Commonwealth Gazette*, No. 173, dated 7th September, 1945.

Commonwealth of Australia.

**NATIONAL SECURITY (GENERAL) REGULATIONS.
ORDER UNDER REGULATION 55.**

In pursuance of regulation 55 of the National Security (General) Regulations and Instrument of Delegation, dated the twentieth day of August, 1945, I, Henry Arthur Showers, the officer performing the duties of Chief of Naval Staff, hereby make the following Order:—

I hereby revoke the Order under Regulation 55, dated 10th February, 1943, and published in the *Gazette* on 17th February, 1943.

Dated this twenty-eighth day of August, 1945.

H. A. SHOWERS,
The Officer Performing the Duties
of Chief of Naval Staff.

(f) *Commonwealth Gazette*, No. 168, dated 31st August, 1945.

Commonwealth of Australia.

**NATIONAL SECURITY (GENERAL) REGULATIONS.
ORDER UNDER REGULATION 59.**

In pursuance of regulation 59 of the National Security (General) Regulations, I, Norman John Oswald Makin, Minister of State for the Navy, hereby make the following Order:—

I hereby revoke the Chronometers and Chronometer Watches Order, dated 20th November, 1940, and published in the *Gazette* on 28th November, 1940.

Dated this twenty-third day of August, 1945.

NORMAN MAKIN,
Minister of State for the Navy.

418.

CONTROLLER OF NAVAL DEMOBILIZATION.

A/Captain J. C. D. Esdaile, O.B.E., A.D.C., R.A.N., has been appointed Controller of Naval Demobilization.

2. His duties comprise all matters concerning demobilization and rehabilitation of the Naval Forces.

(561/225/7.)

419.

TRANSFER—N.A.P. TO R.A.N.V.R.—CERTIFICATES OF SERVICE.

It has been brought to the notice of the Naval Board that following on the transfer of N.A.P. personnel to the R.A.N.V.R., certain H.M.A. establishments have opened new Certificates of Service for the ratings concerned. This practice is unnecessary.

2. The service of all ex-N.A.P. ratings is to continue to be shown on N.A.P. Certificates of Service and Navy Office letter 554/201/348 of 20th November, 1944, quoted as authority for the change of rating on 1st November, 1944.

(453/202/1026.)

420.

**BURSARIES FOR CHILDREN OF PERSONNEL KILLED OR
DISABLED DURING THE PRESENT WAR.**

The King George's Fund for Sailors has established a Fund by which bursaries tenable at schools in New South Wales are to be made available to children of Naval personnel killed or disabled in this war.

2. Bursaries are to be known as the "King George's Fund for Sailors Bursaries" and no more than twenty will be operative at any one time.

3. They will be tenable at any Public School or Private School in New South Wales approved by the Committee. (By Public School is meant not a State School which latter includes Primary, High and Technical Colleges.) There being no fees payable at State Schools, bursaries will not be tenable at them though in certain cases the Fund will assist with grants for books, &c., where approved by the Principal. Application for these subsidiary grants should be made in the same manner as for a full bursary.

4. Each bursary will be to the value of twenty-five pounds (£25) per annum and will be tenable for three years subject to satisfactory reports from the Principal. They may be renewable for a further period after the expiration of three years on the recommendation of the Principal.

5. Application for a bursary is to be made through the Head-master or Head-mistress at the school at which the boy or girl is attending or intends to attend. The Principal of the school must certify that the candidate is a desirable candidate from the educational angle. Such applications should be sent by the Principal to the office of the Flag Officer-in-Charge, N.S.W., Wylde Street, Potts Point, Sydney, marked "School Bursaries" and must be received not later than 1st January each year.

6. Candidates must be not less than 14 years of age as at 1st February in the year of application.

7. The Fund will assist financially in the education of boys and girls under the age of fourteen. Application for such assistance should be made in the same manner as for older children.

8. All applications for bursaries are to show the rank or rating of father, name of father, official number where applicable, and ship in which killed or disabled.

9. The choosing of the bursaries to be awarded will be made by the Flag Officer-in-Charge, Sydney, and the domestic and financial circumstances of the parents will be taken into consideration in awarding the bursaries.

10. Navy Order 65 of 1945 is cancelled.

(552/201/1250.)

(This Order will be reprinted for posting on Notice Boards.)

421.

GIRL GUIDES' HOLIDAY GIFT TO THE R.A.N. PATRIOTIC FUND OF VICTORIA.

The Girl Guides Association of Victoria has given a sum of £2,000 to be known as the Girl Guides' Holiday Gift to the Royal Australian Naval Patriotic Fund of Victoria. The interest of this sum is to be used for the specific purpose of defraying the cost of yearly holidays in camp for children of Naval personnel resident in Victoria.

2. The Scheme embraces children aged from 7 to 15 years. The holiday normally provided is a week at a Guide or other approved Camp (e.g., National Fitness). In addition, all expenses are provided to cover a week's holiday, other than at a Camp, for up to 30 boys and girls each year.

3. Applications should be made to the R.A.N. Family Welfare Bureau, 455 Collins Street, Melbourne, (Telephone Central 5198).

4. Navy Order 535 of 1943 is cancelled.

(552/201/1090.)

(This Order will be reprinted for posting on Notice Boards.)

422.

VACANCIES IN THE REPATRIATION DEPARTMENT.

In order to cope with the activities of the repatriation commission arising out of the demobilization of the forces, the Commission is desirous of securing the services of a number of clerks for its Branch Office in each State.

2. It is desirable that appointees should be ex-service personnel who have had overseas service.

3. Appointment in the first instance will be on a temporary basis but with prospects of permanency as additional classified positions are created.

4. Staff selected for classified (i.e., permanent) positions will be required to pass a medical examination for superannuation purposes, and the appointments will be subject to conditions similar to those obtaining in the Commonwealth Public Service as regards hours of duty, sick and recreation leave and long-service furlough, &c.

5. The commencing salary grade ranges from £322 per annum, with annual increments of £12 per annum, to a maximum of £358 per annum. Classified positions within that group and the higher salary grades are governed by the "work value" of the particular position to which an employee is appointed.

6. Applications must be made in writing addressed to the Deputy Commissioner of Repatriation in the State in which the applicant desires engagement, and should include full name, rank or rating, date of birth, whether married or single, educational qualifications and full details of previous clerical experience.

(860/201/6.)

(This Order will be reprinted for posting on Notice Boards.)

Q.F. 4-in.—MODIFICATION.

with 4" Quadruple Ammunition

to prevent accidental un-keep bars.

7 (appended to this Order).

will be supplied, on demand, Munitions Depot, Sydney.

opportunity.

(490/203/1298.)

INCORPORATED IN W/T, A/S, SETS.

for accounting for naval stores sets are re-promulgated hereunder concerned.

Individual set are to be dealt with as for purposes, the underlying principles of each set are essential to the particular set is fulfilling its function; accepted that these components

should be made to the accounting and establishments, except in the case of the following modifications will, for vessels under construction, and in the case of new naval store ledgers. The sets in ships in commission, or under construction, a set is replaced completely by the set is supplied. In these latter cases the Officer (Naval Storekeeping) may be required to make necessary alterations to the naval store

the following will be as follows:—

For each complete set, the components are to be listed in the relevant establishment list.

Indicating the separate components of each set, they should be compared with the list for the set, and the set then

(Radar Set, A/S Set, etc.), Type of components as detailed in establishment list No.

It should be noted on the vouchers for the several components, and the vouchers then bundled in the usual manner.

421.

GIRL GUIDES' HOLIDAY (

The Girl Guides Association be known as the Girl Guides' Patriotic Fund of Victoria. The specific purpose of defraying children of Naval personnel re

2. The Scheme embraces a holiday normally provided is a (e.g., National Fitness). In a week's holiday, other than at year.

3. Applications should be Bureau, 455 Collins Street, M

4. Navy Order 535 of 1943

(This Order will be repr

422.

VACANCIES IN THE

In order to cope with the arising out of the demobilization of securing the services of a n in each State.

2. It is desirable that appoin have had overseas service.

3. Appointment in the first in with prospects of permanency as

4. Staff selected for classifi required to pass a medical exami the appointments will be subject in the Commonwealth Public Ser recreation leave and long-service

5. The commencing salary gr annual increments of £12 per ann Classified positions within that g governed by the "work value" employee is appointed.

6. Applications must be mad Commissioner of Repatriation in engagement, and should include f whether married or single, educa previous clerical experience.

(This Order will be reprinted for posting on Notice Boards.)

423.

CARRIERS AMMUNITION QUADRUPLE Q.F. 4-in.—MODIFICATION.

Ships concerned	.. All ships fitted with 4" Quadruple Ammunition Carriers.
Nature of Modification	.. Fit spring latch to prevent accidental unlatching of keep bars.
Drawing	.. D.O.T.M. 79647 (appended to this Order).
New Parts required	.. Spring latches will be supplied, on demand, by Gun Mounting Depot, Sydney.
By whom to be done	.. Ship's staff.
Degree of urgency	.. At first opportunity.

(490/203/1298.)

424.

ACCOUNTING FOR NAVAL STORES INCORPORATED IN W/T, A/S, RADAR, ETC., SETS.

Instructions relating to the procedure for accounting for naval stores incorporated in W/T, A/S, Radar, &c., Sets are re-promulgated hereunder for the information and guidance of all concerned.

2. The actual components of each individual set are to be dealt with as one complete unit for store accounting purposes, the underlying principle being that the several individual components of each set are essential to its satisfactory performance and that, if the particular set is fulfilling its service function satisfactorily, it may be accepted that these components are duly present in the set.

It is not desired that any alteration should be made to the accounting procedure in force in existing ships and establishments, except in the circumstances referred to hereunder, and the following modifications will, for the time being, be instituted only in vessels under construction, and in instances where it is necessary to prepare new naval store ledgers. The modified system may also be put into force in ships in commission, or under refit, and in shore establishments, where a set is replaced completely by another set, or where an additional set is supplied. In these latter instances, the services of an Inspecting Officer (Naval Storekeeping) may be applied for to assist in effecting the necessary alterations to the naval store ledgers.

3. The modified method of accounting will be as follows:—

- (a) One ledger page will be used for each complete set, the components of which are detailed in the relevant establishment list.
- (b) On receipt of supply notes indicating the separate components comprising the complete set, they should be compared with the relevant establishment list for the set, and the set then taken on charge as—

W/T Transmitting Set (Radar Set, A/S Set, etc.), Type
.....comprising components as detailed in establish-
ment list No..... 1 No.

The ledger page should be noted on the vouchers for the several components, and the vouchers then bundled in the usual manner.

APPROVED :- 12-1-45

AMENDMENTS.

DATE.	NATURE.
4-9-45	GENERAL ARRANGEMENTS ITEM 2:- MINOR CORRECTIONS. ITEM 3:- THICKNESS OF LUG ADDED. L.V. APPROVED F.W.S. D.O.T.M.

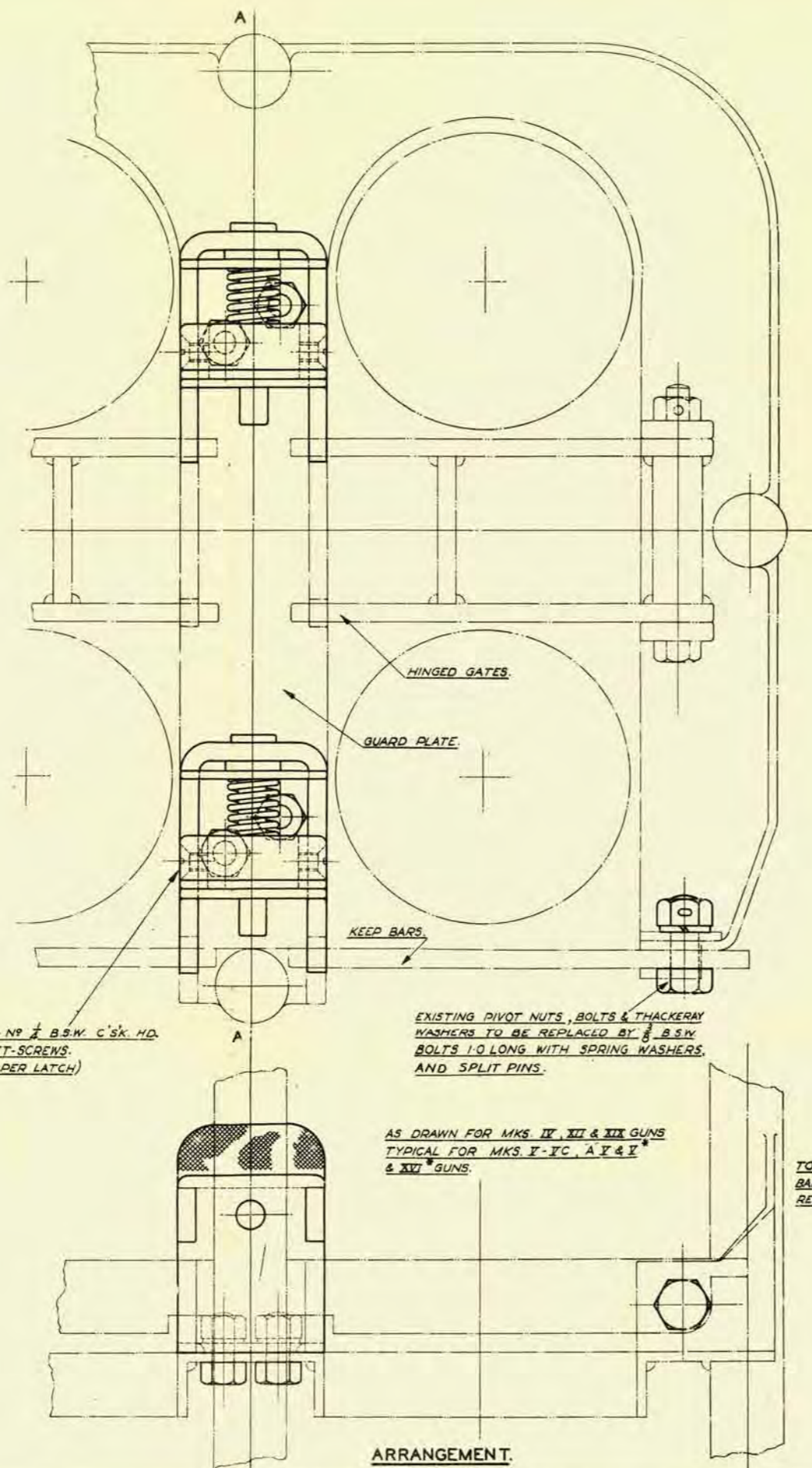

4- NO $\frac{1}{4}$ B.S.W. C.S.K. HD. SET-SCREWS. (2 PER LATCH)

EXISTING DIVOT NUTS, BOLTS & THACKERAY WASHERS TO BE REPLACED BY $\frac{3}{8}$ B.S.W. BOLTS 1.0 LONG WITH SPRING WASHERS AND SPLIT PINS.

AS DRAWN FOR MKS. IV, XII & XIX GUNS
TYPICAL FOR MKS. V-VC, A V & Y
& XVI GUNS.

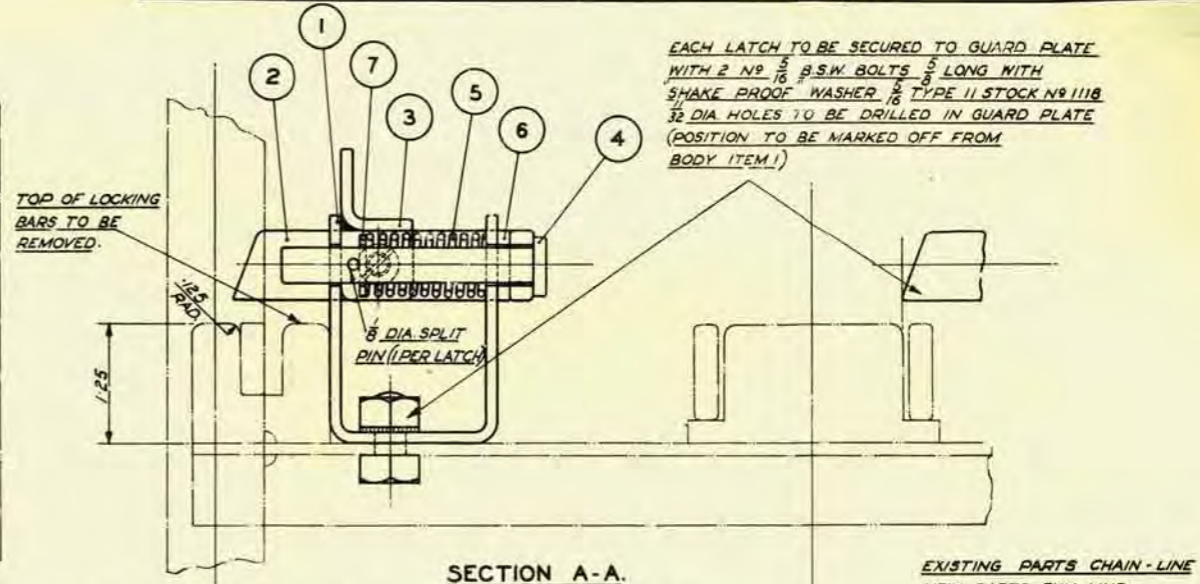
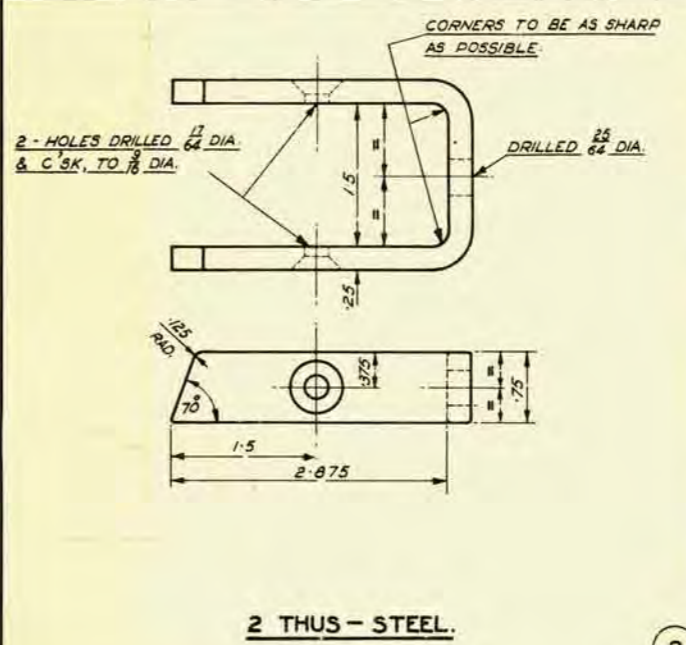
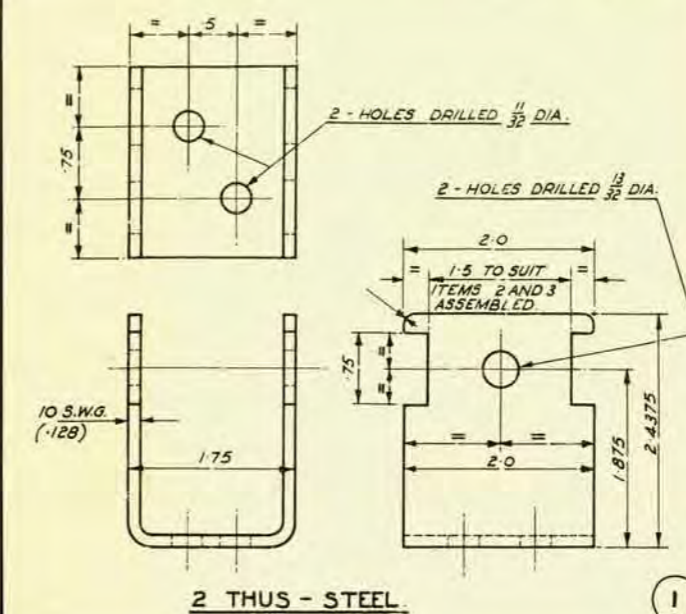

EXISTING PARTS CHAIN-LINE
NEW PARTS FULL LINE.

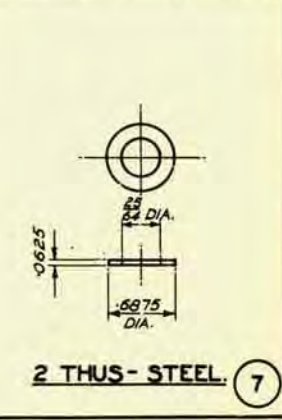
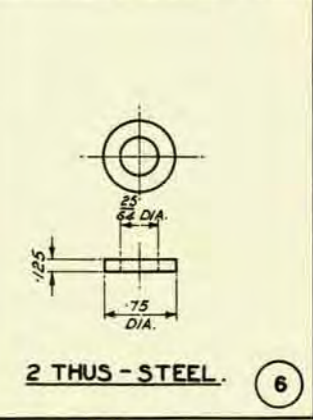
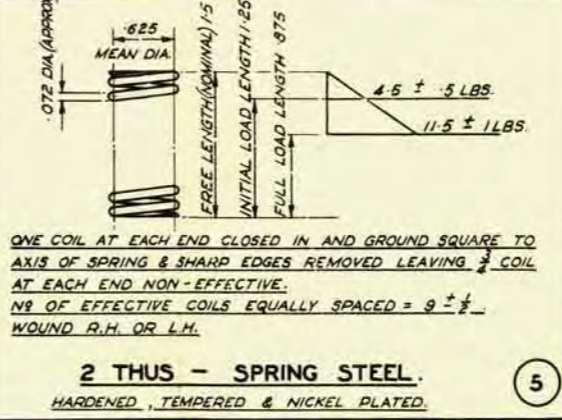
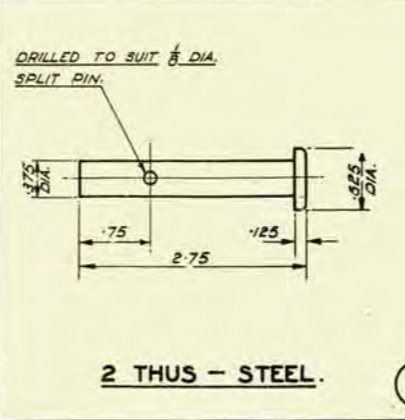
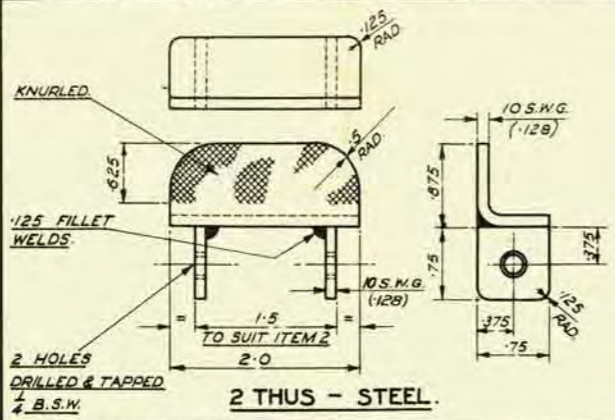

D.O.T.M.
79647.

DIMENSIONS ARE IN INCHES.
SCALE:- 1/4

DRAWN AS PASSED. TB.
TRACED. WGL.
CHECKED. WGL.
APPROVED. WGL.

CARRIER, AMMUNITION, QUADRUPLE, Q.F. 4 INCH, MKS. V - VC, A V & Y & XVI GUNS, MK II.
CARRIER, AMMUNITION, QUADRUPLE, Q.F. 4 INCH, MKS. IV XII & XIX GUNS.

LATCH, KEEP BARS & HINGED GATES - ASSEMBLY & DETAILS OF.

INSTRUCTIONS TO GUIDE MODIFICATION TO LOCKING BARS & FITTING OF LATCHES TO KEEP BARS & HINGED GATES.

- (c) The complete set should be issued on permanent loan as a set and shown in the appropriate permanent loan list as described on the ledger page, *vide* (b) above, a copy of the relevant establishment list being filed with the loan list.
- (d) Spares and accessories, both permanent and consumable, which are allowed by establishment, will continue to be accounted for as at present, i.e., a separate ledger page is required for each description of item. When an accessory of a permanent nature is issued on permanent loan, it should be recorded in the permanent loan columns of the ledger and recorded separately on the permanent loan list. When, however, a spare permanent item is issued in lieu of a defective component of a complete set, it should be issued outright and written off charge in the serviceable column of the ledger. The defective item should be taken on charge as unserviceable and later returned to the dockyard, a serviceable item being obtained in lieu to restore the spares carried in the ship to the authorized allowance as per the establishment list concerned.

Whilst all transactions in the spares and accessories should be recorded in the ledger, the establishment list for the particular set should only be noted when a reduction, or addition, to the original quantity of a component is involved, i.e., when a component is returned defective and replaced by a serviceable spare no alteration is necessary in the establishment list.

- (e) In the event of a component of a set, a spare of which is not allowed *vide* the establishment list, requiring replacement, it will be necessary for the defective component to be taken on charge in the unserviceable ledger, and written off charge on return to a naval store depot. When the replacement is received from the Naval Store Officer, the item should be taken on charge in the serviceable stores ledger, issued outright and written off charge therein.

It will be noted that such transactions will be recorded in the ledger, but the items will not remain on charge therein. In order to avoid raising a separate ledger page for each such item, a ledger page for each separate set or assembly should be raised, and all transactions in the components thereof for which spares are not carried recorded therein.

- (f) (i) When a set is to be modified or converted to another set, particulars of the stores required for modification or conversion are notified in the relative Navy Order, Confidential Commonwealth Navy Order, &c., and supply is effected without demand by the Superintending Naval Store Officer, Sydney.
- (ii) Upon receipt, modification or conversion stores are to be taken on charge in the Naval Store Account in the usual manner. They are then to be issued outright to the Departmental Officer concerned on Forms A.S. 156, any replaced items being returned from the Departmental Officer on Form A.S. 1091, taken on charge in the Naval Store Account and returned to the Superintending Naval Store Officer, Sydney. Any spares or accessories included amongst the modification or conversion stores should be dealt with as indicated in paragraph 3 (d) above.

- (iii) If the modification does not involve a change in the type of the set, any items which are to be incorporated therein (i.e., permanent components or consumable items to be fitted) should be entered in the "as fitted" column of the permanent loan copy of the pertinent Establishment List, and the Registered Nos. of the relevant Forms A.S. 156 endorsed thereon. Similarly, any items removed from the set as a result of the conversion should be deleted from the "as fitted" column of the Establishment List and the Registered Nos. of the Forms A.S. 1091 quoted.

- (iv) When the modification or conversion does involve a change in the type of the set, a conversion voucher indicating that the set has been converted from one type to another is to be prepared, *vide* Article 38 of B.R. 4, and the registered Nos. of the Issue and Return Vouchers, A.S. 156 and A.S. 1091 quoted thereon. The pertinent ledger page and the Permanent Loan Lists are to be endorsed:—

"Converted to Type.....See Form A.S. 127 No.....
Bundle Date....."

4. The appendix to this Order illustrates the ledger posting involved in the various transactions referred to.

5. The above procedure is applicable to each set comprised under the following headings, the details of the components of which are incorporated in establishment lists of stores:—

W/T.
Radar.
A/S.
E/S.
Wa/T.
Hydrophone.
Sound Reproduction.
VC/VF.

6. The scale of distribution of Establishment Lists for the abovementioned types of equipment is as follows:—

SCALE OF DISTRIBUTION OF ESTABLISHMENT LISTS FOR W/T, A/S, RADAR, ETC., EQUIPMENT.

Type of Equipment to which Applicable.	Distribution.	Remarks.
W/T and/or R/T ..	A, B, C ..	A = H.M.A. Ships and Naval Establishments — Two copies of all Establishment Lists applicable to the various sets fitted. One of these copies is required by the Store Accounting Officer for permanent loan list purposes and as an Establishment, the other copy being for the use of the Professional Officer concerned. Superintending Naval Store Officer, Sydney; Naval Store Officer, Brisbane; Naval Store Officer, Fremantle; Officer in Charge, Naval Store Depot, Melbourne.—Two copies each

SCALE OF DISTRIBUTION OF ESTABLISHMENT LISTS FOR W/T, A/S, RADAR, ETC.
EQUIPMENT—continued.

Type of Equipment to which Applicable.	Distribution.	Remarks.
WA/T	A, B, C	B = Squadron and Flotilla Officers, etc.—One copy of all Establishment Lists applicable to sets fitted in ships comprising the Squadron or Flotilla, &c., for use of the Squadron/Flotilla, &c. Officer concerned
Sound Reproduction	A, B, C	
VC/VF	A, B, D	C = Naval Officers-in-Charge, Sydney, Brisbane, Fremantle, Darwin, Port Melbourne, New Guinea.—One copy of each list. (For use of Port W/T Officer.)
A/S	A, B, E, F	D = Naval Officer-in-Charge, Sydney, Brisbane, Townsville, Cairns, New Guinea, Darwin, Fremantle.—One copy of each list. (For use of Port Signal Officer.)
E/S	A, B, E, F	E = Naval Officers-in-Charge, Fremantle, Port Melbourne, Brisbane, Cairns, Darwin, Townsville.—Two copies of each list. (For Port A/S Officer.)
Hydrophone	A, B, G	F = Naval Officer-in-Charge, New Guinea; Rushcutter.—Three copies of each. (For Port A/S Officer.)
Radar	A, B, H, I	G — Rushcutter.—Three copies of each H = Naval Officers-in-Charge, Sydney Brisbane, Fremantle, Darwin, New Guinea, Townsville, Port Melbourne (for Port Radar Officers), Port Adelaide (for Radar Fitting Officer) and H.M.A. Radar School.—Two copies of each local Radar Establishment List. (For Port Radar Officer.) I = Naval Officer-in-Charge, Fremantle and H.M.A. Radar School.—One copy of each Admiralty and Local Radar Establishment List for Survey Depot

7. Navy Orders 139, 311, and 502 of 1944 are cancelled.

(612/212/2688.)

APPENDIX.

S.—153. LEDGER FOR PERMANENT STORES.

Complete Set vide Paragraph 3.

F.1.—W/T Transmitting Set Type 35S comprising Components as detailed in Establishment List No. T.17. No.

Date.	Voucher No.	Serviceable Stores.			Grand Total on Loan.	Unserviceable Stores.			Date.	Voucher No.	Torpedo W/T.		
		Re-ceipts.	Issues.	Re-mains.		Re-ceipts.	Issues.	Re-mains.			Issued.	Re-turned.	Total on Loan.
1944.	First Charge.								1944.				
Aug. 8	9713	1		1									
	9720				1				Aug. 15	S156	1		
										4003 W/T		1	

NOTES.—A. Entry for receipt of set from Dockyard.
B. Entry for issue of set on Permanent Loan to W/T Department.

COMPONENT PARTS NOT CARRIED AS SPARE PER ESTABLISHMENT LIST OF STORES.
Pat. 4530A. Ammeter 4½" Dial Hot Wire.

Sept. 10	W/T 1051					1		1				
" 15	714							1		Nil		
" 18	9504	1		1								
" 18	W/T 4172			Nil								
Pat. 4558. Bell High Voltage 220 Volts.												
Oct. 12	W/T 1162					1		1				
" 13	821							1		Nil		
" 27	10062	1		1								
" 27	W/T 5021			Nil								

NOTES.—A. Entry for return of unserviceable items from W/T Department to Naval Store.
B. Entry for return of unserviceable item from ship to Dockyard.
C. Entry for supply of serviceable item in lieu from Dockyard.
D. Entry for supply of serviceable item in lieu to W/T Department.

SPARES ALLOWED BY ESTABLISHMENT.

Aug. 8	8432	1		1								
Aug. 31	W/T 1001					1*		1				
Aug. 31	W/T 416			Nil								
Sept. 4	702							1		Nil		
" 15	9708	1		1								

NOTES.—A. Initial supply from Dockyard.
B. Return of unserviceable item from W/T Department and issue of serviceable item in lieu.
C. Return of unserviceable item to Dockyard.
D. Supply of serviceable item in lieu from Dockyard.
* Component incorporated in set and not on separate ledger charge.

ACCESSORIES ALLOWED BY ESTABLISHMENT.

Aug. 8	8434	1		1								
" 10	W/T 1005					1						
Sept. 15	W/T 4057			Nil	Nil	1		1		1		1
" 17	704							1				
" 24	9031	1		1								
" 25	W/T 1020				1							1
Aug. 10	W/T 1005								1			1
Sept. 15	W/T 4057									1		1
Sept. 25	W/T 1020										1	1

NOTES.—A. Initial Supply from Dockyard.
B. Issue on Permanent Loan to W/T Department.
C. Return of unserviceable item to Naval Store from W/T Department.
D. Return of unserviceable item to Dockyard.
E. Receipt of serviceable item in lieu from Dockyard.
F. Issue of serviceable item to W/T Department on permanent loan.

425.

WOODEN FOLDING CAMP STRETCHERS—REPLACEMENT.

The existing type of wooden folding camp stretcher, 6' 2" x 2' 3" is being replaced by an all-metal and fireproofed dwarf collapsible type camp stretcher.

2. It is not proposed to recall the wooden camp stretchers but the new all-metal type will be issued to replace any wooden type returned and condemned as unfit for further naval service.

(612/235/990.)

426.

DEMANDS FOR DRY PROVISIONS IN DARWIN, NEW GUINEA AND MOLUCCAS AREAS.

In order to reduce to a minimum losses due to deterioration of dry stores in the Darwin, New Guinea, and Moluccas areas, future demands for replenishment lodged by ships and shore bases in those areas are not, subject to paragraph 2 hereof, to exceed quantities required to complete to a maximum of two months' estimated requirements, and then only when satisfactory storage facilities for the period exist.

2. When special circumstances necessitate increased stocks being maintained temporarily in a ship or base, the approval of the Naval Officer-in-Charge of the area is to be indicated in the body of each demand concerned.

(668/211/844.)

427.

CONCENTRATED HARDENED BUTTER—USE OF, BY SMALL SHIPS.

All small ships, the refrigerated accommodation of which is limited to domestic type refrigerators, are in future to restrict sea stocks of fresh butter to a maximum of seven days' estimated requirements. Any requirements in excess of that period are to be met by the supply of concentrated hardened butter, particulars of which are contained in Navy Order 563 of 1944.

2. Concentrated hardened butter may be demanded from the Royal Edward Victualling Yard, all Victualling Depots and from V.S.I. Ships.

(668/201/3000.)

428.

ECONOMY IN THE USE OF STATIONERY.

It is notified by the Commonwealth Stores Supply and Tender Board, that, owing to the shortage of labour for the manufacture of envelopes, considerable difficulty has again been experienced in letting contracts for Commonwealth requirements.

2. It is therefore necessary that the strictest economy should be exercised in the use of envelopes to ensure that supplies on hand or in sight may be made to last as long as possible.

3. Requisitions are to be carefully scrutinized and every care taken to reduce demands to a minimum.

(544/202/1026.)

429.

DEMOBILIZATION FORMS.

The undermentioned forms have been introduced for use in the R.A.N. :—

Form Demob. 4—Dispersal Data Form.

(825/201/46.)

Form R.A.N. Demob. 7—Vocational Guidance Report Form.

(825/201/65.)

2. Initial supply will shortly be made without demand to authorities indicated hereunder :—

Commanding Officer, H.M.A.S. *Rushcutter.*" " " *Lonsdale.*" " " *Moreton.*" " " *Torrens.*" " " *Leeuwin.*" " " *Huon.*

3. A small stock is held by the Superintending Naval Store Officer, Sydney, on whom demands for replenishment may be placed.

(825/201/86.)

430.

FORM A.S. 5—CASH ADVANCES OR TRANSFERS—VOUCHER REFERENCE TO BE QUOTED ON FORM A.S. 5.

It is noted that Forms A.S. 5 received in Navy Office, are in many instances incompletely filled in and omit reference to the cash voucher No. of the ship raising the form.

2. Form A.S. 5 will be revised at next reprint to provide for fuller references to be inserted. In the meantime, all Forms A.S. 5 raised are to be endorsed (original and duplicate copies) with the cash account voucher Nos. (consecutive and registration) and month and year of payment, of the ship raising the Form A.S. 5; the Supply Officer acknowledging the advance is also to insert the name of the Parent Ship.

3. Forms A.S. 5 raised by shore establishments or offices are to be endorsed with the consecutive and registration Nos. and month of payment of the Form N.A. 4 making the advance.

4. The voucher reference endorsement should appear at the top right hand corner of the Form A.S. 5.

(Specimen notation) " H.M.A.S. " " "

or

Establishment or Office.....

Voucher (Consec.)/(Regtrn.)

No. No.

.....(month)..... 194..... "

and a specimen entry of the detail required in the body of Form A.S. 5 is—

" *Naval Appropriation Suspense Account*

To advance of cash to.....H.M.A.S. " " "

for payment of Ships company for fortnight ending.....

Advance to be transferred to Supply Officer, H.M.A.S. "....."

(Parent Ship)."

(480/202/4773.)

431.

BOOKS AND FORMS.

First supplies of the undermentioned publications have been distributed. Further supplies of B.R.'s 1078 and 1244 are being obtained to complete distribution :—

A.B.R. 2/45.—Handbook on Naval Teleprinter Procedure (Australia).
(571/202/2207.)

B.R. 9A.—Admiralty Gyro Compass (Sperry Type) with Non-Hunting Follow Up.

B.R. 9B.—The Admiralty Gyro Transmission Unit, Mark 1.
(571/202/1918.)

B.R. 70.—Signal Letters of British Ships—December Supplement.
(A.F.O. 2804/45.)
(571/202/2042.)

B.R. 150.—Aircraft Recognition Manual—Amendments Nos. 7, 8, and 9.

(A.F.O. 1490/45.)
(571/202/1646.)

B.R. 268 (19).—Electrical Manual, Volume II.—Instructions for the Operation, Adjustment and Maintenance of Auto Selector Switches and Associated Apparatus (Whipp and Bourne).
(A.F.O. 847/45.)
(571/202/2040.)

B.R. 371 (3).—Establishment of Naval Stores for Boom Working Vessels—Errata No. 3.

(A.F.O. 6480/44.)
(571/202/1428.)

B.R. 381.—Establishment of Naval Stores for 126 ft. Motor Minesweepers also Errata No. 1.

(A.F.Os. 4010/43 and 1782/45.)
(612/226/1210.)

B.R. 445.—A Form of Prayer and Hymns for Active Service.

B.R. 447.—A Service Book, Enlarged Edition.

B.R. 448A.—Holy Communion.

(A.F.O. 1981/43.)
(571/202/2103.)

Annexe Nos. 47-53.—International List of Telegraph Offices.

(A.F.O. 1906/45.)
(571/202/1814.)

B.R. 796/44.—Handbook of Periodical Maintenance Routines for 21* Mark VIII.* Torpedoes.

(A.F.O. 6484/44.)
(571/202/2178.)

B.R. 847/44.—Handbook for 2 pdr., Q.F. Mark VIII. Gun on Marks VII. and VII.* P. Mounting. This book supersedes B.R. 847/43. and O.U. 6357 (2). O.U. 6357 is also obsolete.

(A.F.O. 4823/44.)
(571/202/1951.)

B.R. 976/44.—The Officer of Quarters' Pocket Book.

(A.F.O. 5105/44.)
(571/202/2075.)

B.R. 980G.—R/T. 592. pages 1-5, June, 1944.

(A.F.O. 6226/44.)

B.R. 980B.—R/T. 588, pages 1-5, May, 1944.

B.R. 980K.—R/T. 587, pages 1-5, May, 1944.

(A.F.O. 4422/44.)

B.R. 980B.—R/T. 608, pages 1-4, December, 1944.

B.R. 980B.—R/T. 609, pages 1-5, December, 1944.

(571/202/2100.)

B.R. 980X.—R/T. 610, pages 1-4, December, 1944.

(A.F.O. 1784/45.)

B.R. 1041 (1).—Equipment of Naval Stores for D.E.M.S., &c.—Errata No. 1.

(A.F.O. 985/45.)
(571/202/1961.)

B.R. 1078.—Docking Information—Landing Craft and Barges.

(A.F.O. 3891/44.)
(571/202/2058.)

B.R. 1207.—Drill for the 25 pdr. Gun Mark II. on the Marks I. and II. (Naval) Mountings.

(A.F.O. 1489/45.)
(571/202/2160.)

B.R. 1223.—Handbook for Cinema Laying and Training Teacher.

(A.F.O. 1350/45.)
(571/202/2158.)

B.R. 1244/44.—Fouling of Ships Bottoms, Identification of Marine Growths by the Marine Corrosion Sub-Committee.

(571/202/2190.)

B.R. 1260.—“This War against Japan” by Ian Morrison, Ministry of Information Publication. “Ocean Front”.

(A.F.O. 1911/45.)
(571/202/2197.)

O.U. 5365A.—Priced Vocabulary of Naval Armament Stores—Part I—Errata Nos. 16 and 17.

O.U. 5365B.—Part II.—Errata Nos. 31 and 32.

O.U. 5365C.—Part III.—Errata Nos. 16 and 17.

O.U. 5365E.—Part V.—Errata No. 3.

(A.F.Os. 6226/44, 474, and 1490/45.)
(571/203/2559.)

W/T Frequency Supplements—Series Y1-Y5/M. 350—November and December, 1945, and January, 1946.

(A.F.O. 2824/45.)
(571/202/2016.)

A.P. 2457A, Volume 1.—Smoke Screening Equipment, corrected up to and including Amendment No. 25.

(571/201/4676.)

Department of Army Publication—General Stores and Clothing
Technical Report No. 1, Accommodation and cover in New
Guinea, March, 1945.

(571/201/4726.)

“Prayers and Hymns for You and Me.”

(431/201/55.)

2. The undermentioned form has been revised. Distribution of first
supply will be effected, without demand, by the Superintending Naval Store
Officer, Sydney, when the existing form will be rendered obsolete.

A.S. 441.—Passing Certificate for Seamen Branch Ratings.

(480/202/4740.)

3. The undermentioned forms have been revised. Distribution will be
effected, on demand, by the Superintending Naval Store Officer, Sydney,
when stock of the existing form is exhausted.

A.S. 1129z.—Record of Issue of Ribbon of Campaign Stars.

(480/202/4550.)

A.S. 1233H.—Trade Certificate Electrical Artificers.

(480/202/4751.)

4. The undermentioned form has been introduced for use in the R.A.N.
Supplies will be issued on demand by the Superintending Naval Store
Officer, Sydney.

D. 742A.—Continuation Sheet—Return of Issues and Receipts of
Gun Mounting and Torpedo Tube Stores.

(480/201/3494.)

By Authority: H. E. DAW, Government Printer, Melbourne.

RESTRICTED.

(FOR OFFICIAL USE ONLY.)

Commonwealth Navy Orders.

Navy Office, Melbourne,

2nd October, 1945.

The following Orders, having been approved, are hereby
promulgated for information and guidance and necessary
action.

By direction of the Naval Board,

Joseph Macandee
Secretary.

*The Commodore Commanding H.M.A. Squadron,
and Commanding Officers of H.M.A. Ships,
Officers in Charge of H.M.A. Naval
Establishments, and others concerned.*

TABLE OF CONTENTS.

No.	Subject.
432.	Appointments.
433.	H.M.S. “Alert”—Commissioning.
434.	H.M.A.S. “Hawk”—Paying off.
435.	H.M.A.S. “Korowa”—Paying off.
436.	Appointment of Inspector of Naval Recruiting and Chief Rehabilitation Officer.
437.	Educational Test I., June, 1945.
438.	Depth Charge Equipment—Modification to Parbuckle Stowage for Mark IV. D.C. Throwers.
439.	Tools for Ordnance and Electrical Mechanics.
440.	Food Coupons—Naval Personnel—Rationing Year 1945-1946.
441.	Radar Control and Radar Plot Scheme—Policy.
442.	Officers’ Working Dress.
443.	H.M.A. Ships Paying off—Return of Naval Armament, Gunmounting, and Torpedo Stores.

432.

APPOINTMENTS.

Admiral Sir Louis H. K. Hamilton, K.C.B., D.S.O., resumed duty as First Naval Member on 20th September, 1945, and Acting Rear-Admiral G. D. Moore, C.B.E., resumed duty as Flag Officer-in-Charge, N.S.W., and Admiral Superintendent, Sydney, on 21st September, 1945.

(404/202/977.)

433.

H.M.S. "ALERT"—COMMISSIONING.

H.M.S. *Alert* (Royal Naval Depot, Sydney) was commissioned as tender to H.M.S. *Woolloomooloo* on 1st September, 1945.

(1804/4/54.)

434.

H.M.A.S. "HAWK"—PAYING OFF.

H.M.A.S. *Hawk* was paid off on 13th September, 1945.

(603/246/5379.)

435.

H.M.A.S. "KOROWA"—PAYING OFF.

H.M.A.S. *Korowa* was paid off on 6th September, 1945.

(675/204/3184.)

436.

APPOINTMENT OF INSPECTOR OF NAVAL RECRUITING AND CHIEF REHABILITATION OFFICER.

A/Commander R. S. Veale, R.A.N.V.R., has been appointed Inspector of Naval Recruiting, in succession to Commander O. A. Jones, R.N.R.

2. In addition, A/Commander Veale will also carry out the duties of Chief Rehabilitation Officer on the Staff of the Controller of Naval Demobilization for the purpose of supervising and co-ordinating the work of Port Rehabilitation Officers and to act as Liaison Officer between the Controller of Naval Demobilization and the Director-General of Manpower.

3. Paragraph 6 of Navy Order 213/1943 is cancelled.

4. Navy Order 269 of 1940 refers.

(432/215/2608.)

437.

EDUCATIONAL TEST I., JUNE, 1945.

The following ratings passed Educational Test I., held on 12th June, 1945:—

Name.	Rating.	O.N.	Result.
<i>H.M.A.S. Cerberus</i> —			
Albrecht, Noel J.	Stoker, 2nd Class	B/5377	Passed
Bayliss, Desmond T.	Stoker, 2nd Class	PA/5161	Passed
Beel, Lawrence F.	Stoker, 2nd Class	27258 ..	Passed
Bell, Mervyn C.	Stoker, 2nd Class	F/5562	Passed
Benjamin, Geoffrey A.	Stoker, 2nd Class	H/2986	Passed
Betts, Mark E.	Stoker, 2nd Class	F/5548	Passed
Bischof, John C.	Stoker, 2nd Class	S/10129	Passed
Brown, Geoffrey D.	Stoker, 3rd Class	F/5673	Passed
Brown, Henry C.	Stoker, 2nd Class	W/3114	Passed
Burgess, Sydney A.	Stoker, 2nd Class	F/5674	Passed
Butters, Murray C.	Stoker, 3rd Class	H/2988	Passed
Coppinger, James H.	Stoker, 2nd Class	PA/5136	Passed
Counsel, William J.	Stoker, 2nd Class	W/3109	Passed
Crabb, Brian	Stoker, 3rd Class	S/9906	Passed
Cruise, Stanley G.	Stoker, 2nd Class	W/2379	Passed
Doolan, John K.	Stoker, 3rd Class	B/5381	Passed
Draper, Kenneth M.	Stoker, 2nd Class	F/5666	Passed
Duffett, Phillip A.	Stoker, 2nd Class	S/9976	Passed
Duffy, Frank D.	Ordinary Seaman	B/5379	Passed
Ferguson, Jack R.	Stoker, 3rd Class	S/10134	Passed
Forbes, Colin R.	Stoker, 3rd Class	F/5557	Passed
Gall, John	Stoker, 2nd Class	S/10053	Passed
Gilchrist, Keith J.	Stoker, 2nd Class	S/10138	Passed
Hampton, Maxwell E.	Stoker, 2nd Class	W/3102	Passed
Hardaker, Keith J.	Stoker, 3rd Class	S/10060	Passed
Hickey, John R.	Stoker, 2nd Class	B/5380	Passed
Hicks, Fred. McK.	Stoker, 2nd Class	PA/5192	Passed
Hopkins, George H.	Stoker, 3rd Class	F/5689	Passed
Howard, Alwin N.	Stoker, 3rd Class	F/5545	Passed
Johnson, Albert R.	Stoker, 3rd Class	F/5461	Passed
Johnson, Allen H.	Stoker, 2nd Class	S/10146	Passed
Jones, David W.	Stoker, 2nd Class	F/5665	Passed
Lang, Geoffrey L.	Stoker, 2nd Class	W/3117	Passed
Laws, Maxwell V.	Stoker, 2nd Class	W/3121	Passed
Lee, Eric J.	Stoker, 2nd Class	S/10029	Passed
Lindsay, Lewis W.	Stoker, 3rd Class	F/5568	Passed
Linton, Leslie F.	Stoker, 2nd Class	W/3090	Passed
Lovell, Gordon M.	Stoker, 2nd Class	S/10030	Passed
MacGregor, Alan B.	Stoker, 3rd Class	F/5682	Passed
McLeod, John	Stoker, 2nd Class	F/5683	Passed
Moran, Colin F. S.	Stoker, 2nd Class	PA/5194	Passed
Palmer, Reginald G. H.	Stoker, 2nd Class	B/5345	Passed
Purchall, Gordon R.	Stoker, 2nd Class	W/3098	Passed
Richard, Pierre E.	Stoker, 2nd Class	W/3091	Passed
Robertson, George T.	Stoker, 3rd Class	S/10161	Passed
Rose, Colin E.	Stoker, 2nd Class	F/5570	Passed
Sims, James W.	Stoker, 2nd Class	F/5653	Passed
Sullivan, Geoffrey W.	Stoker, 2nd Class	W/3118	Passed
Suter, Gerald C.	Stoker, 2nd Class	H/2913	Passed
Terrance, Ronald M.	Stoker, 3rd Class	S/9960	Passed
Vanstone, Jeff A.	Stoker, 3rd Class	S/10064	Passed
Webster, Mervyn R.	Stoker, 2nd Class	S/9921	Passed

EDUCATIONAL TEST I, JUNE, 1945—continued.

Name.	Rating.	O.N.	Result.
<i>H.M.A.S. Glenelg—</i>			
Scott-Halliday, James A. ..	Ordinary Seaman ..	S/9753	Passed
<i>H.M.A.S. Hawkesbury—</i>			
Cowper, Peter R. ..	Able Seaman ..	PM/6770	Passed
Knoke, Leonard H. ..	Able Seaman ..	S/8094	Passed
Pearson, Jack E. ..	Stoker ..	PA/4487	Passed
Rafton, Frederick A. ..	Stoker ..	W/2945	Passed
Roberts, Arthur J. ..	Stoker ..	B/4934	Passed
<i>H.M.A.S. Hobart—</i>			
Blencowe, John C. H. ..	Leading Steward ..	21321	Passed
<i>H.M.A.S. Manoora—</i>			
Clarke, Lawrence B. ..	Stoker ..	F/4196	Passed
Nicholds, James E. ..	Stoker ..	W/2567	Passed
<i>H.M.A.S. Norman—</i>			
Saltmarsh, Lloyd W. ..	Petty Officer (Ty.) ..	23459	Passed
<i>H.M.A.S. Westralia—</i>			
Blessington, Matthew C. ..	Stoker, 2nd Class ..	S/9625	Passed

The following qualified educationally for Acting Leading Stoker:—

<i>H.M.A.S. Cerberus—</i>			
Boniwell, William C. ..	Stoker, 2nd Class ..	H/2995	..
Burns, Hamish B. ..	Stoker, 3rd Class ..	F/5688	..
Clark, Brian C. ..	Stoker, 2nd Class ..	PA/5135	..
Craig, Harry R. ..	Stoker, 2nd Class ..	H/2990	..
Earl, William E. ..	Stoker, 2nd Class ..	W/3104	..
Edwards, Peter W. ..	Stoker, 3rd Class ..	H/2962	..
Forsyth, Raymond R. ..	Stoker, 3rd Class ..	F/5588	..
Foxley, Raymond E. ..	Stoker, 3rd Class ..	S/10069	..
Gage, Keith B. ..	Stoker, 2nd Class ..	PA/5190	..
Hancock, Richard E. ..	Stoker, 2nd Class ..	H/2991	..
Hills, Brian G. ..	Stoker, 2nd Class ..	F/5717	..
Hines, Kevin ..	Stoker, 2nd Class ..	S/10059	..
Jones, Douglas M. ..	Stoker, 2nd Class ..	B/5342	..
Kester, Allen F. ..	Stoker, 2nd Class ..	W/3122	..
Lawson, Douglas T. ..	Stoker, 2nd Class ..	PA/5138	..
Laycock, Kenneth F. ..	Stoker, 2nd Class ..	W/3112	..
McKell, Allen J. ..	Stoker, 3rd Class ..	S/9955	..
McRae, John ..	Stoker, 2nd Class ..	W/3120	..
O'Neill, Royton J. ..	Stoker, 3rd Class ..	H/3008	..
Payne, John W. ..	Stoker, 2nd Class ..	PA/5195	..
Pryse, Maxwell T. ..	Stoker, 2nd Class ..	W/3100	..

EDUCATIONAL TEST I, JUNE, 1945—continued.

Name.	Rating.	O.N.	Result.
<i>H.M.A.S. Cerberus—continued.</i>			
Purchase, Robert W. ..	Stoker, 2nd Class ..	W/3095	..
Russell, Victor H. ..	Stoker, 2nd Class ..	W/3113	..
Speed, William F. ..	Stoker, 2nd Class ..	W/3124	..
Tait, Leonard V. ..	Stoker, 2nd Class ..	W/3111	..
Turra, Dante O. ..	Stoker, 2nd Class ..	S/9961	..
Way, Robert G. ..	Stoker, 2nd Class ..	PA/5048	..
Williams, George A. ..	Stoker, 3rd Class ..	S/10172	..
Wilson, George H. L. ..	Stoker, 2nd Class ..	W/3089	..
Wilson, Keith A. ..	Stoker, 2nd Class ..	W/3108	..
<i>H.M.A.S. Glenelg—</i>			
Johnston, Neville J. ..	Stoker ..	B/4371	..
<i>H.M.A.S. Hawkesbury—</i>			
Munday, Edmond J. ..	Stoker ..	H/2143	..
<i>H.M.A.S. Westralia—</i>			
Harper, David W. ..	Stoker, 2nd Class ..	S/9482	..

(465/205/668.)

(This Order will be reprinted for posting on Notice Boards.)

438.

DEPTH CHARGE EQUIPMENT—MODIFICATION TO PARBUCKLE STOWAGE FOR MARK IV. D.C. THROWERS.

It has been found necessary to restrict the movement of depth charges in the parbuckle stowage for Mark IV. D.C. throwers in order to prevent them from being damaged.

2. The following modification is to be carried out at the next occasion of refit:—

All portable stop bars are to be replaced by modified type stop bars, in accordance with the appended diagram.

3. The Commanding Officers of ships concerned are to raise an alteration and addition item to cover this work, quoting this Order as authority.

(603/280/1729.)

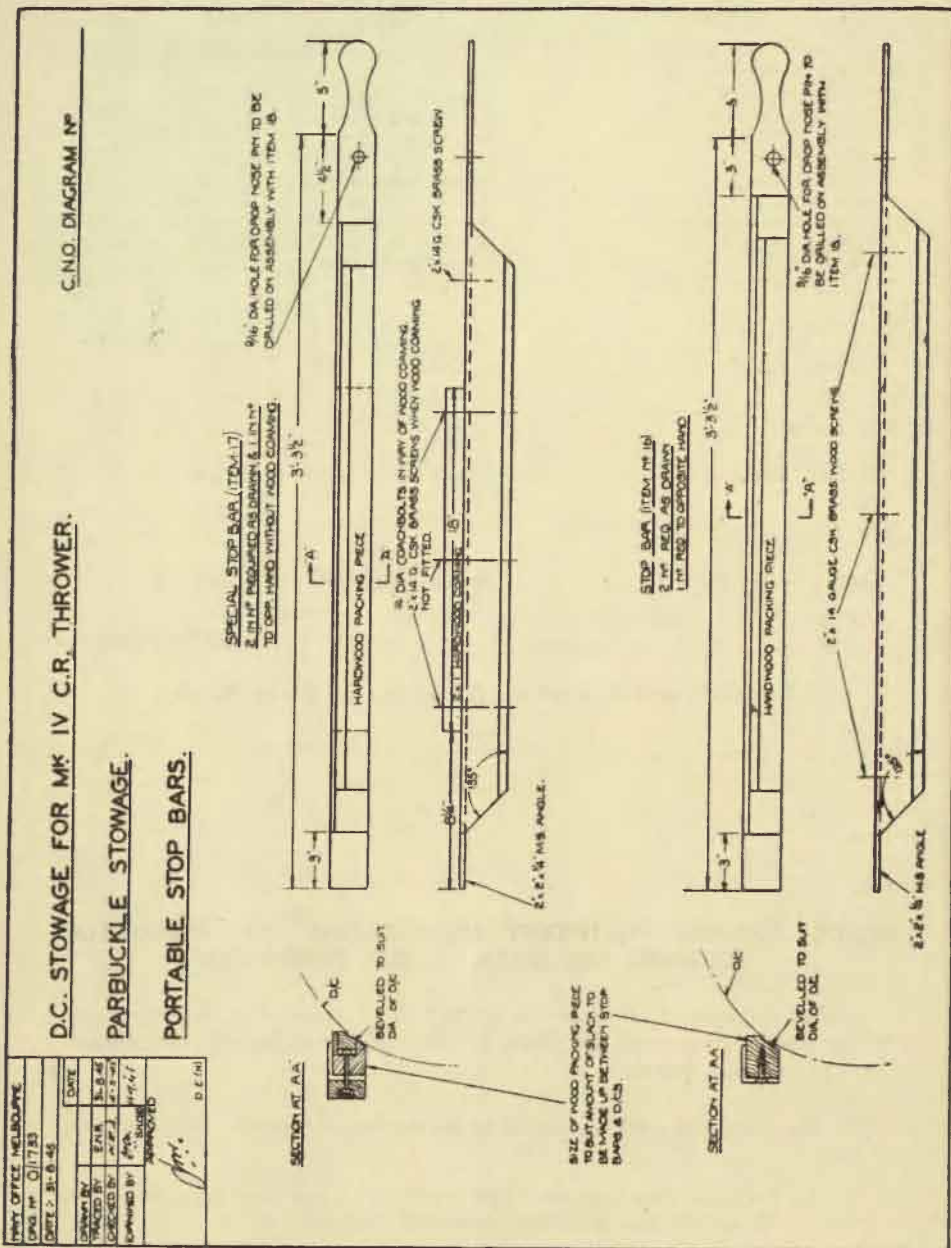

439.

TOOLS FOR ORDNANCE AND ELECTRICAL MECHANICS.

Approval has been given for the provision of tool kits as per appendices "A" and "B" for the use of ordnance and electrical mechanics borne in H.M.A. ships.

2. The kits of tools should be issued from ships' Naval Stores on temporary loan to these mechanics, any items not available on board being demanded from the nearest naval store depot or base naval store.

3. Care should be taken to ensure that the tool kits are returned to store prior to the mechanics, to whom issued, being drafted from the ships concerned.

APPENDIX A.**ORDNANCE MECHANICS—TOOL KITS.**

<i>Item.</i>	<i>Quantity.</i>
Rule, Steel, 12", marked on 2 edges—10ths.—100ths and millimetres	1 No.
" " 6", marked on 2 edges—8ths.—64ths.	1 "
Dividers, spring, 6"	1 Pr.
Callipers, inside, 4"	1 "
" " outside, 4"	1 "
Scriber	1 No.
Square, 4" blade	1 "
Gauge, depth	1 "
" " screwpitch (Whitworth 4 to 60 threads per inch)	1 "
Vice, hand, 4 1/2"	1 "
Pliers, side cutting	1 Pr.
" " gas	1 "
" " multigrip	1 "
Hammer, ball, pane, 1/2 lb.	1 "
" " " 1 lb.	1 "
Screwdrivers (large, medium, 1 small)	1 No. of each
Punches 1/16" to 3/16"	1 Set
Punch, centre	1 No.
Chisel, cold, flat, 3/4"	1 "
" " " crosscut, 1/4" or 3/8"	1 "
" " " round nose	1 "
Snips, tin	1 Pr.
Spanners, crescent wrench—medium size	1 No.
" " " small size	1 "
Scrapers (half round curved, flat, triangular)	1 Set
Hacksaw	1 No.
Box tool, approximately 18" x 10" x 8"	1 "

APPENDIX B.**ELECTRICAL MECHANICS—TOOL KITS.**

<i>Items.</i>	<i>Quantity.</i>
*Pliers, side cutting (similar to patt. 823 pliers side cutting large, but in a 6" size)	1 Pr.
* " " quickgrip, small to take up to 3/8" nut, patt. 825	1 "
* " " electrician's, 8", insulated handles	1 "
* " " diagonal	1 "
* " " side cutting, long nosed	1 "
* " " multi-grip	1 "
*Screwdriver, flat blade 4", 1/8" tip } with non-metal handles	1 No.
* " " " 6", 1/4" tip }	1 "
* " " " 8", 3/8" tip }	1 "
*Bag, canvas, woollen bottomed, 12" x 4" base, standing 8" high to carry above tools, fuse, earth lamps, etc.	1 "

APPENDIX B.—*continued.*

Items.	Quantity.
*Spanner, adjustable, 6", to take $\frac{3}{4}$ " nut 1 No.
Punch, centre 1 "
Chisel, cross cut, 3/16" 1 "
" flat, $\frac{1}{2}$ " 1 "
" round note 1 "
Hammer, ball pane, 1 lb. 1 "
Lamp, blow, small 1 "
Rule, steel 12", graduated 1/16", 1/10" and metric 1 "
Scriber, steel 1 "
Scraper, flat 1 "
" half round 1 "
Hacksaw, frame, 12" 1 "
Vice hand 1 "
Callipers outside, 4" 1 Pr.
" inside 4" 1 "
Dividers, spring, 6" 1 "
Square 4" 1 No.
Spanner, crescent, 6" 1 "
Drill, hand, to take up $\frac{1}{4}$ " drill 1 "
Snips, tin, 10" 1 Pr.
Wrench, "Stillson," 8" 1 No.
Box, tool, approx. 18" x 10" x 8" 1 "

Note.—Tools marked * are issued to wiremen and torpedo ratings, *vide* C.O.R., Article 404, and electrical mechanics already in possession of * items should only be supplied with tools required to complete the mechanic's kit.

(524/214/1049.)

440.

FOOD COUPONS—NAVAL PERSONNEL—RATIONING YEAR, 1945-1946.

The 1945-46 rationing year commenced on Monday, 4th June, 1945, upon which date the current Food Ration Sheet for the Defence Services was brought into operation. Each individual food coupon sheet for a half-week contains the following:—

Tea	one-half coupon,
Sugar	one-quarter coupon,
Butter	one-half coupon,
Meat	two half coupons,

the quantitative value being one-half of the corresponding civilian coupon.

2. This Food Ration Sheet is common to the Navy, Army, and Air Services, including Royal Australian Naval Nursing Service and Women's Royal Australian Naval Service. Coupons are negotiable whenever presented, and are not limited to a specific period as in the case of civilian coupons.

3. *Entitlement to Food Ration Coupons.*—Specially printed sheets representing a "half week" entitlement of rationed food commodities are issuable to the following personnel:—

(a) Personnel proceeding on leave.

(b) Personnel in receipt of provision allowance or victualling allowance and not specially permitted to purchase from Service stocks of provisions.

(c) Personnel on consolidated rates of pay, other than Naval Dockyard Police and civilian canteen staffs who retain their civilian ration books.

4. For leave purposes coupons are to be issued to each person on the following scale:—

Period of Leave.	Coupon Entitlement.
1 to 3 days	1 sheet of combined coupons,
4 to 7 days	2 sheets of combined coupons,
8 to 10 days	3 sheets of combined coupons,
11 to 14 days	4 sheets of combined coupons,
15 to 17 days	5 sheets of combined coupons,
18 to 21 days	6 sheets of combined coupons'

and so on, but in no case are coupons to be issued at any one time for a period exceeding 28 days.

When issues are made for periods of two weeks or more, one butter half-coupon and one meat half-coupon are to be excised or cancelled in ink, or by indelible stamp, for each two weeks' entitlement. Periods of less than two weeks are to be disregarded. Monthly returns of coupon transactions are, in accordance with paragraph 8 (b) (iv) of this Order, to include a certificate that such action has been taken.

The surrender of food coupons is not required for meals at a hostel, hotel, or other residential establishment, if period of stay is less than six days in any one fortnight. Personnel are to be informed, when such accommodation is anticipated, that coupon issue is not to be applied for.

5. In addition to the personnel referred to in paragraph 2, issue may be made to all sea-going personnel serving in Naval Establishments who are granted "short leave" to visit their homes as defined in Naval Financial Regulations and Instructions, Article 170. Entitlement is one "half-week" coupon sheet for each half-week to such personnel as are granted regular short leave. "Home" may be interpreted, at the discretion of the Commanding Officer, as including the home of a near relative (e.g., parent, sister, or brother).

6. *Requisitioning of Coupon Supplies.*—Sheets, each containing twenty (20) "half-week" combined coupons, are to be requisitioned from the State Deputy-Director of Rationing by Naval Officers-in-Charge at Sydney, Brisbane, Fremantle, Port Adelaide and Hobart, for issue to H.M.A. Ships and Establishments and to other Naval Authorities within or adjacent to their districts. Naval Officers-in-Charge, Flinders Naval Depot, Port Melbourne, and Darwin are to requisition upon the Director of Victualling.

Sea-going ships are to obtain requirements from the most convenient of the authorities referred to. Requirements of tenders and outlying stations are to be met by parent ships or base depots. Personnel returning from outlying stations or areas where stocks of coupon sheets are not held are to report to the Naval Authority at their first port of arrival on the mainland for coupon issue.

7. *Custody of Coupons, Accounting and Returns.*—Stocks are to be held in the custody of a responsible officer, and coupons are only to be issued on the authority of the Commanding Officer, who is responsible that a suitable record is maintained of all receipts and issues and that every precaution is taken to avoid abuses or unauthorized issues.

8. The following returns are to be rendered to the Director of Victualling at the end of each calendar month :—

- (a) By Naval Officers-in-Charge, indicating—
- (i) Number of coupons received.
 - (ii) Number of coupons issued.
 - (iii) Ships, other than tenders, supplied.
 - (iv) Number of coupons remaining in hand.
- (b) By Commanding Officers of establishments and of sea-going ships, indicating—
- (i) Number of coupons received during the month and sources of supply.
 - (ii) Number of coupons issued.
 - (iii) Number of coupons remaining.
 - (iv) Compliance with paragraph 4, sub-paragraph 2, of this Order in regard to cancellation of coupons.

9. Navy Orders 266 and 605 of 1944 are cancelled.

(350/201/138.)

441.

RADAR CONTROL AND RADAR PLOT SCHEME—POLICY.

With reference to Navy Order 155 of 1945, Table "B" is to be amended by the addition of the following, to Note (i) :—

"Ratings who have been confirmed as Petty Officer (Radar) prior to qualifying to Seamanship, should be transferred to Acting Petty Officer with the appropriate provisional non-substantive rating, but they will not be required to change back to Class II. uniform pending subsequent confirmation as Petty Officer."

(348/218/1.)

442.

OFFICERS' WORKING DRESS.

With reference to paragraph 3 of Navy Order 316 of 1945, it has not been practicable to include items of Officers' Working Dress in the agreements under which outfitters supply Officers' uniforms.

2. The rates at which supplies may be obtained from the Commonwealth Government Clothing Factory are as follows, viz. :—

Jackets	£1 10s. ea.
Trousers	£1 4s. 9d. pr.

(434/215/1126.)

443.

H.M.A. SHIPS PAYING OFF—RETURN OF NAVAL ARMAMENT, GUNMOUNTING, AND TORPEDO STORES.

The following instructions are to be observed in connection with return of Naval Armament, Torpedo and Gunmounting stores from H.M.A. Ships paying off into Reserve or for disposal :—

(a) *Ships Paying off for Disposal.*—All ammunition 40 m.m. and below stowed in Ready Use lockers and all "exposed" small arm ammunition is to be dumped in deep water prior to paying off. The remainder of the outfit of Naval Armament, Torpedo and Gunmounting stores is to be returned to the Naval Armament, Torpedo, or Gunmounting Depot at the paying off port or, where such depots do not exist, to the Naval Officer-in-Charge for despatch to the nearest appropriate depot.

(b) *Ships Paying off into Reserve at Extended Notice (i.e., 4 Months).*—

Stores to be disposed of as in (a) above except as follows :—

(i) Gun bodies 3 pdr. and above to be retained on board in a state of preservation.

(Mechanisms, spare parts and appurtenances, etc., for such guns to be landed and retained at the port where the ship is held in reserve.)

(ii) A proportion of fireworks as arranged with the Senior Officer in charge of ships in reserve to be retained.

(iii) Gunmountings 3 pdr. and above to be retained on board in a state of preservation. (Spare parts, etc., for such mountings to be landed and retained at the port where the ship is held in reserve.)

(iv) Torpedo tubes are to be retained on board in a state of preservation.

2. Store accounts are to be closed on return of stores as above and forwarded to Navy Office with all supporting documents.

3. Lists are to be prepared in triplicate of all Naval Armament and Whitehead torpedo stores which are necessarily retained on board in accordance with paragraph 1 (b) and distributed as follows :—

Naval Armament Stores—

Original guarded in fixture list.

Duplicate forwarded with closed account.

Triplicate to Naval Armament Supply Officer.

Whitehead Torpedo Stores—

Original guarded in fixture list.

Duplicate forwarded with closed account.

Triplicate to Torpedo Depot.

4. Notes in regard to preservation of equipment are appended :—

Preservation of Guns.—Bores are to be coated with a mixture of 95 per cent. mineral jelly and 5 per cent. beeswax and hermetically sealed at both ends by waxed wooden plugs tightly inserted and rendered watertight by the application of putty.

Exteriors are to be painted with one coat of red lead paint followed by one of service grey. Where abnormal deterioration of the paint is likely to occur, a second coat of service grey may be applied. Clinometer planes are not to be painted but are to be heavily coated with a mixture of white lead and tallow and the preserving covers secured in place. The breech openings of guns with sliding type of breech block are to be regarded as exterior parts.

Holes for fixing screws are to be plugged with greasy tow and putty.

Counterbalance weights, if fitted, are to be removed.

Preservation of Mountings.—To be thoroughly scraped and painted where necessary. Rollers and all movable parts, pivot bolts, etc., to be coated with mineral grease.

Preservation of Torpedo Tubes.—To be thoroughly cleaned, oiled and painted when necessary. All working surfaces, steel parts, springs, valves and guide strips are to be well coated with mineral grease.

Rubber pads and fittings are to be coated with graphite paste.

(612/202/3754.)

By Authority: H. E. DAW, Government Printer, Melbourne.

RESTRICTED.

(FOR OFFICIAL USE ONLY.)

Commonwealth Navy Orders.

Navy Office, Melbourne,
9th October, 1945.

The following Orders, having been approved, are hereby promulgated for information and guidance, and necessary action.

By direction of the Naval Board,

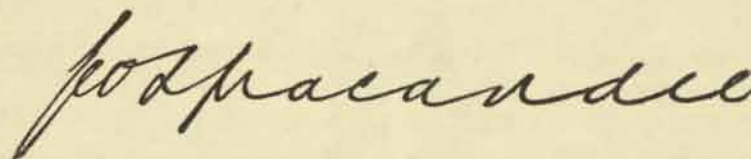

Secretary.

*The Commodore [Commanding H.M.A. Squadron,
and Commanding Officers of H.M.A. Ships,
Officers in Charge of H.M.A. Naval
Establishments, and others concerned.*

TABLE OF CONTENTS.

No.	Subject.
444.	H.M.A.S. "Winter"—Paying Off.
445.	H.M.A. G.P.V. 959—Commissioning.
446.	Expected Times of Arrival for Commissioned Ships.
447.	Naval Officer-in-Charge, Albany—Termination of Appointment.
448.	Port Directors.
449.	Pilotage—Claims for.
450.	Maintenance of Refrigerator and Air Conditioning Equipment in H.M.A. Ships.
451.	Collection of Income Tax by Instalments—Members of the Forces Released on Leave for Seasonal Occupations.
452.	Ratings' and Band Ratings' Made-to-measure Uniforms—Commonwealth Government Clothing Factory Prices.
453.	Packages Supplied with Victualling Stores.
454.	Recovery of Value of Stores Lost by Neglect.
455.	Books and Forms.

444.

H.M.A.S. "WINTER"—PAYING OFF.

H.M.A.S. "Winter" was paid off on 25th September, 1945.

(603/246/5358.)

445.

H.M.A. G.P.V. 959—COMMISSIONING.

H.M.A. G.P.V. 959 was commissioned on 19th September, 1945.

(603/246/2509.)

446.

EXPECTED TIMES OF ARRIVAL FOR COMMISSIONED SHIPS.

For purposes of making expected times of arrival of commissioned ships, the following points are to be used:—

BRISBANE	Pile light.
SYDNEY	Hornby light.
MELBOURNE	Port Phillip Heads.
ADELAIDE	Outer Harbour Breakwater.
FREMANTLE	Breakwater.

(603/247/1926.)

447.

NAVAL OFFICER-IN-CHARGE, ALBANY—TERMINATION OF APPOINTMENT.

The appointment of the Naval Officer-in-Charge, Albany, was terminated on 24th September, 1945.

2. The Sub-Collector of Customs has resumed his normal duties as Admiralty Reporting Officer.

(2021/7/339.)

448.

PORT DIRECTORS.

With reference to Navy Order 425 of 1944, a Royal Australian Navy Port Director was appointed at Koepang, on 13th September, 1945.

(1937/2/315.)

449.

PILOTAGE—CLAIMS FOR.

Payment of pilotage has been approved by the Naval Board in respect of the undermentioned ports in the South-West Pacific Area. These are in addition to those listed in O.U. 5284/38.

Place.	Limiting Draft.	
Napier Broome	Sea to anchorage south of Galley Point	10 feet
Admiralty Gulf	Sea to south of Tancred Bank	..
Dundas Strait and Van Diemen Gulf	Admiralty Gulf to Port Warrenda	..
Vansittart Bay	Passage through
King Sound	Sea to anchorage
.. .. .	Sea to anchorage, King Sound	..
.. .. .	King Sound to anchorage, Derby Harbour	..
.. .. .	Derby Harbour alongside, Derby	..
Broken Bay	Sea to anchorage, Pittwater	..
Shark Island	D.G. Range (Port Jackson)	20 feet, length
..	450 feet
Welshpool	Sea to jetty	6 feet
Corner Inlet	Sea to anchorage	10 feet
Westernport	Sea to Naval Depot
Jackdaw Channel	Passage through
Hornbill Channel	Passage through
Tufi Harbour	Sea to anchorage
Buna Harbour	Sea to anchorage
Guasopa Harbour	Sea to anchorage
East Cape to Cape Ward Hunt	Passage through
Watutu Point to Kadalawa Point (Goodenough to Trobriand Is.)	Passage through
Seadler Harbour (Admiralty Is.)	Sea to anchorage	20/450 feet
Segond Channel (New Hebrides)	Sea to anchorage	20 feet
Mios Woendi	Sea to anchorage	10 feet
Deboyne Lagoon	Sea to anchorage between Tg. Gila and Tg. Wajaboela	..
Sorido Lagoon (Riak)	Sea to anchorage
Dreger Harbour	Sea to anchorage
Kossol Roads	Sea to anchorage

2. The following ports have recently been considered for pilotage and no claim (except under exceptional circumstances) will be allowed in respect thereof:—

Humboldt Bay.
Madang.
Finschhaven.
Aitape.
Hansa Bay.
Ramu River.
Halmahera Sea.
Coral Sea.

(407/218/453.)

450.

MAINTENANCE OF REFRIGERATOR AND AIR CONDITIONING EQUIPMENT IN H.M.A. SHIPS.

The responsibility for the maintenance of refrigerator and air conditioning equipment in H.M.A. Ships will revert to the Navy.

2. Navy Order 666 of 1944 will apply generally. Paragraph 2 of that Order is to be amended by the addition of the following sub-paragraph:—

“(f) Refrigerator and air conditioning spares:—Paragraph 15 is applicable as regards procedure for replenishment of spare parts.”.

3. Navy Order 128 of 1945 is hereby cancelled.

(549/201/148.)

451.

COLLECTION OF INCOME TAX BY INSTALMENTS—MEMBERS OF THE FORCES RELEASED ON LEAVE FOR SEASONAL OCCUPATIONS.

In cases where members of the Royal Australian Navy are granted leave for harvesting operations before 31st December, 1945, the Commissioner of Taxation has agreed that they may be granted exemption from instalment deductions until 31st December, 1945.

2. In this connection, a certificate should be completed in duplicate as per *pro forma* below, the original being retained by the member and the duplicate forwarded to the Deputy Commissioner of Taxation in the State referred to in the certificate.

3. The member of the Forces to whom the certificate is issued must present the certificate to his employer in order that the employer may be satisfied that he is authorized to refrain from making tax instalment deductions from the earnings of that member.

4. It should be noted that any income received by a member of the Forces from harvesting operations is subject to tax and that the arrangement now authorized relates only to the deduction of instalments from that income.

5. In order to assist Commanding Officers in carrying out the procedure which has been outlined above, the names and addresses of the Deputy Commissioners of Taxation in the several States are set out hereunder:—

R. W. Chenoweth, Esq.,
Deputy Commissioner of Taxation,
436 Lonsdale-street,
Melbourne, C.1.

J. W. Hughes, Esq.,
Deputy Commissioner of Taxation,
Box 4197, G.P.O.,
Sydney, N.S.W.

C. G. Corkell, Esq.,
Deputy Commissioner of Taxation,
Cr. George and Elizabeth Streets,
Brisbane, Q'land.

W. P. Bishop, Esq.,
Deputy Commissioner of Taxation,
Box 288-A, G.P.O.,
Adelaide, S.A.

M. D. Mears, Esq.,
Deputy Commissioner of Taxation,
Box A. 15, G.P.O.,
Perth, W.A.

E. C. Botten, Esq.,
Deputy Commissioner of Taxation,
649-B, G.P.O.,
Hobart, Tas.

D. J. Coates, Esq.,
Acting Deputy Commissioner of Taxation,
for the Northern Territory,
Box 360-D, G.P.O.,
Adelaide, S.A.

PRO FORMA.

This is to certify that the member of the Naval Forces whose signature appears in the margin hereof has been released from Naval duties for the purpose of assisting in harvesting operations and is covered by an authority issued by the Deputy Commissioner of Taxation, for.....* which authority reads as follows:—

“This Certificate, which is issued in pursuance of the provisions of the *Income Tax Assessment Act 1936-1945* is an authority which exempts the employer of.....† from the liability to make deductions from the salary or wages payable to him during the period from the date of issue of this Certificate to the 31st December, 1945.”

Signature of Member of the Naval Forces

‡ R. W. CHENOWETH,
Deputy Commissioner of Taxation,
Taxation Office,
436 Lonsdale-street,
Melbourne, C.1.

Signature of Commanding Officer.

Ship or Depot.
Date.

* Here insert the name of the State in which the member of the Naval Forces was enlisted.
† Here insert the full name of the member of the Naval Forces to whom the Certificate is issued.
‡ Name and address of Deputy Commissioner to be stencilled or printed according to the State concerned.

(621/201/6769.)

452.

**RATINGS' AND BAND RATINGS' MADE-TO-MEASURE UNIFORMS—
COMMONWEALTH GOVERNMENT CLOTHING FACTORY PRICES.**

The following prices, operative from 1st August, 1945, at which ratings' made-to-measure uniforms may be obtained from the Commonwealth Government Clothing Factory are promulgated for general information, viz. :-

Ratings—

<i>Article.</i>	<i>£ s. d.</i>
Jackets, Diagonal Serge, with Gilt Buttons C.P.O.
„ Diagonal Serge, with Gilt Buttons P.O.
„ Diagonal Serge, with Horn Buttons
„ Seamen's Serge, with Gilt Buttons C.P.O.
„ Seamen's Serge, with Gilt Buttons P.O.
„ Seamen's Serge, with Horn Buttons
Jumpers, Drill without Tape on Collars	0 15 0
„ Serge	0 19 9
Overcoats, Cloth with Gilt Buttons
„ Cloth with Horn Buttons
Trousers, Diagonal Serge, Fly	1 4 6
„ Seamen's Serge, Fly	1 3 9
„ Seamen's, Fall	1 7 6
„ White Drill, Fly	0 18 6
Tunics, Drill, with Gilt Buttons, C.P.O.
„ Drill, with Gilt Buttons, P.O.
„ Drill, with White Horn Buttons
„ Drill, without Buttons	1 1 0
Waistcoats, Diagonal serge, with Gilt Buttons
„ Diagonal serge, with Horn Buttons
„ Seamen's Serge, with Gilt Buttons
„ Seamen's Serge, with Horn Buttons

Band Ratings—

Greatcoats, khaki cloth	4 16 9
Trousers, blue serge	1 9 0
„ khaki drill	1 1 9
Tunic, blue serge, unlined	2 18 6
„ khaki drill, with buttons	1 13 3
„ khaki drill, without buttons	1 11 9

(434/215/1103.)

(This Order will be reprinted for posting on Notice Boards.)

453.

PACKAGES SUPPLIED WITH VICTUALLING STORES.

In view of the termination of hostilities, special arrangements are to be made by all ships to conserve to the utmost extent possible all accountable victualling containers for return to a supply ship or base at

the first opportunity. Supply and receipt notes are to be passed in the normal manner and the general peace provisions of C.O.R., Article 506, closely observed.

2. The foregoing was promulgated in A.I.G. 103, T.O.O. 031701 September, and is now embodied in Navy Orders for ready reference.

(421/201/1005.)

454.

RECOVERY OF VALUE OF STORES LOST BY NEGLIGENCE.

The following general signal, T.O.O. 261359 September, is included in Navy Orders for the guidance of all concerned :-

“Reference-Naval Financial Regulations and Instructions Article 9, clause 3. Until further notice, Commanding Officers are to investigate, as soon as detected, all cases of deficient stores or stores lost by neglect and assess liability on form A.S. 126 whether or not the value exceeds five pounds.

2. Where the value exceeds five pounds, the matter should be reported to Navy Office, as provided in clause 4 of Article 9, but recovery is on all occasions to be effected forthwith in accordance with the Captain's decision.

3. Where deficiencies or other losses of stores by neglect are detected only after an officer or rating has been discharged to a demobilization depot, the matter is to be immediately reported to Navy Office in addition to taking other normal action.

4. The foregoing procedure is to be closely observed in order to ensure that charges for losses due to neglect are made immediately, whenever practicable, or at latest before personnel are demobilized.”

(556/201/2212.)

455.

BOOKS AND FORMS.

The undermentioned form has been introduced for use in the R.A.N. Distribution will be effected without demand, to authorities concerned by the Officer-in-Charge, Naval Store Depot, Port Melbourne :-

R.A.N. Demobilization 9—Discharge Depot Routine Card.

(480/201/3596.)

2. The undermentioned forms have been revised. Distribution will be effected on demand by the Superintending Naval Store Officer, Sydney, when stock of the existing form is exhausted :-

I.B. 3—Report of Inspection of Ordnance.

(480/201/3586.)

R.A.N.R. 6—Application for Enlistment and Form of Engagement in R.A.N.R., R.A.N.V.R. and W.R.A.N.S.

(480/203/505.)

3. The undermentioned form has been adopted for use in the R.A.N. :—

B. 96—Passing Certificate for Stoker Petty Officer.

(480/201/3565.)

4. The undermentioned form has been adopted for use in the R.A.N. Distribution will be effected, without demand by the Superintending Naval Store Officer, Sydney :—

S. 311A (part). Torpedo Log—Progress Book—(Routine on D.C. Pistols and Equipment).

(A.F.O. 2132/44.)

(480/202/4615.)

5. The undermentioned forms have been revised. Supplies of the revised forms will be distributed on demand by the Superintending Naval Store Officer, Sydney :—

A.S. 462, Part III. incorporating A.S. 462, Part II.—Quarterly Account of Implements, Galley Gear and Mess Utensils, &c.

(480/202/4653.)

A.S. 462Z—Monthly Account of Provisions Received and Expended and Mess Book.

(480/202/4763.)

RESTRICTED.

(FOR OFFICIAL USE ONLY.)

Commonwealth Navy Orders.

Navy Office, Melbourne,
16th October, 1945.

The following Orders, having been approved, are hereby promulgated for information and guidance, and necessary action.

By direction of the Naval Board,

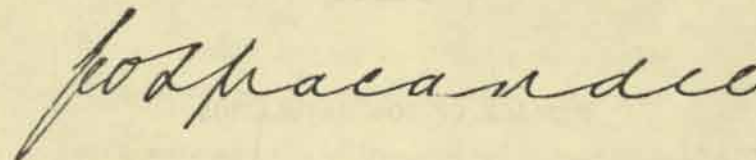

Secretary.

*The Commodore Commanding H.M.A. Squadron,
and Commanding Officers of H.M.A. Ships.
Officers in Charge of H.M.A. Naval
Establishments, and others concerned.*

TABLE OF CONTENTS.

No.	Subject.
456.	Naval Officer-in-Charge, Rabaul.
457.	H.M.A. M.L. 813—Paying off.
458.	Message of Congratulation.
459.	Entry to Enclosed Wharves.
460.	H.M.A. Ships Paying off—Naval Armament Store Accounts.
461.	Q.F. Gun Drill—Care in loading to avoid Damage to Fuzes.
462.	Radar Beacons.
463.	Orders for Fresh Provisions.
464.	Optical or Specialized Medical and Surgical Instruments.
465.	Advancement of Ratings—Notation of Seagoing Recommendations on Conduct Sheets and Notations on A.S. 264.
466.	Contracts for Supply of W.R.A.N.S. Ratings' Made-to-Measure Jackets and Skirts.
467.	Contracts for Supply of Ratings' Made-to-Measure Uniforms.
468.	Re-Establishment of H.M.A. Naval Victualling Depot, Darwin.

456.

NAVAL OFFICER-IN-CHARGE, RABAUL.

A Naval Officer-in-Charge was appointed at Rabaul on 18th September, 1945.

(1889/3/186.)

457.

H.M.A. M.L. 813—PAYING OFF.

H.M.A. M.L. 813 was paid off on 1st October, 1945.

(603/294/1514.)

458.

MESSAGE OF CONGRATULATION.

The following message has been received on the occasion of the surrender of the Japanese Empire and is promulgated for information:—

The President of the Senate: (To the Minister for the Navy.)

“In accordance with the direction of the Senate, I am transmitting to you hereunder the terms of a Resolution which was agreed to unanimously by the Senate on Wednesday, 12th September, upon the motion of the Minister for Trade and Customs (Senator the Hon. R. V. Keane):—

That the thanks of the Senate be accorded to the officers, warrant officers, petty officers, and men of the Royal Australian Navy, for their heroic services in every theatre of war, for the guardianship of Australia from the attacks of our enemies, for their unceasing vigilance in the patrol of many seas, for their courage and skill in convoying their soldier comrades and supplies to operational areas, and for the prestige they have won for their country wherever they have been.

That the thanks of the Senate be accorded to the officers, warrant officers, non-commissioned officers, and men of the Australian Military Forces in the field for their courage and efficiency, their endurance in circumstances of unexampled hardship, for their magnificent achievements and for their undaunted spirit which has carried them through years of toil and suffering to complete victory.

That the thanks of the Senate be accorded to the officers, non-commissioned officers, and men of the Royal Australian Air Force for their brilliant daring and conspicuous skill over land and sea, and for their calm courage and devotion to whatever dangerous and vital duties they have been allotted.

That the thanks of the Senate be offered to the men of the Merchant Navy, who carried out the vital task of keeping open the supply lines, always at great risk and imposing severe tests upon their endurance.

That the thanks of the Senate be accorded to the women of all the auxiliary services of the three arms of the fighting forces for their devotion and skill and solicitude for the sick and wounded of our sailors, soldiers, and airmen.

That the Senate records its deep appreciation of the devotion and sacrifice of the fathers, mothers, wives, and sisters of Australia's sailors, soldiers, and airmen.

That the Senate records its deep appreciation of the efforts, money and gifts from the women, men, and children of Australia to mitigate the hardships of Australian fighting men, to alleviate the lot of our prisoners of war and to make more comfortable the sick and wounded.

That the thanks of the Senate be offered to munitions and war workers generally in secondary and primary industries; to those men of 1914–18 who gave valuable home service in garrison and other work, and to the Volunteer Defence Corps.

That the Senate acknowledges with deep submission and reverence the heroism of those who have fallen in the service of their country, and tenders its sympathy to their relatives in the hour of their sorrow and their pride.

I desire to ask that you will be good enough to have the terms of the above Resolution brought to the notice of all personnel referred to therein who come under your administration.”

(443/202/301.)

(This Order will be reprinted for posting on Notice Boards.)

459.

ENTRY TO ENCLOSED WHARVES.

The issue of permits to enter enclosed wharves has now been discontinued and National Security (General) Regulation 7A, insofar as it relates to permits for entry on to enclosed wharves, may now be regarded as inoperative.

2. Navy Orders 366 of 1941 and 493 of 1943 are cancelled.

(553/201/483.)

460.

H.M.A. SHIPS PAYING OFF—NAVAL ARMAMENT STORE ACCOUNTS.

With reference to paragraph 2 of Navy Order 443 of 1945, care is to be taken, when H.M.A. Ships pay off, that the Naval Armament Store Account is completed and closed in accordance with the instructions printed throughout the ledger (Forms F.A. 30, S. 1423, or S. 1423A). The attention of ships using Form F.A. 30 is particularly drawn to pages V. and VI., paragraphs 28, 29, 30, 31, 32, and 33.

2. The ledger should contain an accurate and complete account of all Naval Armament Stores received, expended, issued or otherwise disposed of (with the exception of packages and arisings, *vide* Navy Order 383 of 1943).

3. The Naval Officer-in-Charge or Naval Armament Supply Officer should, if necessary, provide the Accounting Officer with suitable office space for closing his account, and with any advice and assistance required, especially with regard to vouchering the stores to be landed. Care should be exercised as far as possible to ensure that the Ship's Return Notes agree with the stores actually returned.

4. The account, when completed and signed by the Commanding Officer on the first and last pages of the ledger, should be handed to the Naval Armament Supply Officer for examination and transmission to Navy Office by registered post. Where there is no Naval Armament Supply Officer, this should be done by the Naval Officer-in-Charge.

5. Owing to the considerable quantities of stores that will be landed at certain paying-off ports, complete check of stores returned will take some time and to avoid undue delay in closing accounts, the ledger, with the exception of small arms, should be posted from the triplicate copies of the Ship's Return Notes, in accordance with Navy Order 328 of 1945. If the receipted duplicate copies of the Return Notes are not received by the time the account is ready for despatch to Navy Office, the account should be forwarded without them, a note being inserted to that effect. The Officer receiving the stores should forward the Receipted Vouchers to Navy Office as soon as possible, with his observations regarding any discrepancies.

6. In the case of small arms (i.e., sub-machine guns, rifles, and pistols) the Return Notes must be checked and receipted prior to closing of the account.

(612/202/3754.)

461.

Q.F. GUN DRILL—CARE IN LOADING TO AVOID DAMAGE TO FUZES.

A report has been received of damage to the rear end of 4-inch Mark XVI* gun chambers in one of H.M.A. Ships caused by careless handling of drill cartridges.

2. The handling of service rounds in this manner would result in severe damage to live fuzes, with resultant blinds and possibly prematures.

3. It is essential for efficiency in action that guns' crews should be trained to load with the same care during gun drill as that necessary when using service ammunition.

(490/203/1249.)

462.

RADAR BEACONS.

Information concerning Radar Beacons in operation is now promulgated in Notices to Mariners.

2. Confidential Commonwealth Navy Orders 119 and 240 of 1944 are cancelled.

(2037/7/1244.)

463.

ORDERS FOR FRESH PROVISIONS.

Condemnations have recently occurred of fresh provisions delivered by contractors at mainland ports after the departure of the ships for which they were intended, no action having been taken by the ships concerned or the local Base Supply Officer of the port to advise the contractor of the cancellation of the order.

2. In all cases where a ship leaves a port prior to the receipt of all fresh provisions ordered, the Base Supply Officer is to be informed of the details of orders undelivered and is to be requested to arrange for their cancellation or other disposal, if such course is necessary.

3. Naval Officers-in-Charge are to incorporate appropriate instructions in local Port Orders.

4. Navy Order 344 of 1941 is cancelled.

(401/201/1697.)

464.

OPTICAL OR SPECIALIZED MEDICAL AND SURGICAL INSTRUMENTS.

In all cases where valuable specialized instruments supplied for Medical or Surgical use become defective, the following procedure is to be adopted:—

Ships Afloat—

- (a) No attempt is to be made at repair.
- (b) The instrument is to be surveyed and returned to Medical Store.
- (c) A demand is to be created for replacement of the instrument, and it will be supplied if in stock.

Shore Establishments—

- (a) No attempt is to be made at repair.

- (b) The instrument is to be surveyed and either returned to Medical Store or forwarded to the local Agent for advice and/or necessary repair.
- (c) In the event of the Agents not being established in the nearest City, the instrument is to be surveyed and returned to the Medical and Dental Store Officer.
- (d) A Demand is to be created for replacement of the instrument and it will be supplied if in stock.

(612/213/3061.)

465.

ADVANCEMENT OF RATINGS—NOTATION OF SEAGOING RECOMMENDATIONS ON CONDUCT SHEETS AND NOTATIONS ON A.S. 264.

Owing to frequent drafting, Forms A.S. 239A (Conduct Sheets) in respect of many ratings, bear a succession of notations "Under three months" in connection with recommendations for advancement (and efficiency assessments), with the result that there is often no record of a rating having been recommended for advancement from a seagoing ship.

2. It has been decided that, in future, the efficiency and advancement columns of conduct sheets of men serving in seagoing ships are to be completed for periods of one month or more, the notation "I.K." (insufficient knowledge) being used, if necessary. In depots and other shore establishments, these columns are to be completed for periods of three months or more. In either case, the columns may be completed for shorter periods if there is sufficient knowledge of the man concerned.

3. The notations on Form A.S. 264 provide a very useful guide in deciding whether a man is recommended for advancement, and care is to be taken that these notations are kept up-to-date.

(568/202/1065.)

466.

CONTRACTS FOR SUPPLY OF W.R.A.N.S. RATINGS' MADE-TO-MEASURE JACKETS AND SKIRTS.

New contracts have been arranged in Melbourne, Sydney, Brisbane, Adelaide, Perth, and Hobart for the supply of W.R.A.N.S. ratings' made-to-measure Jackets and Skirts for the period ending 30th June, 1946.

2. The contracts have been arranged for the convenience of W.R.A.N.S. ratings who wish to purchase made-to-measure garments, and particular attention is invited to the conditions set out in sub-paragraph 5 (c). Ratings should insist on contractors observing the conditions, which provide for at least one try-on in the basted or unfinished condition and a final try-on in the finished state, in order to ensure satisfactory fit.

3. The names and addresses of the contractors are:—

Melbourne—Messrs. David Lack, Finlay's Buildings, cr. Little Lonsdale and Elizabeth streets.

Sydney— Messrs. David Jones Ltd., Marlborough-street, Surry Hills.

Brisbane— Messrs. Brakes Pty. Ltd., 518 Stanley-street, South Brisbane.

Adelaide— Messrs. Ashford Clothing Co., 98 North Terrace; Messrs. Reg. Habib, Dell's Buildings, Twin-street.

Perth— Messrs. The National Clothing Co. (1939) Ltd., 40 King-street.

Hobart— Messrs. Garretts Pty. Ltd., 102 Bathurst-street.

4. The prices for the supply of the uniforms are as follows, and are inclusive of the cost of all materials:—

	Melbourne.	Sydney.	Brisbane.	Adelaide.	Perth.	Hobart.
	£ s. d.	£ s. d.	£ s. d.	£ s. d.	£ s. d.	£ s. d.
Jacket, double-breasted, diagonal serge, with gilt buttons for C.P.O.	3 1 6	3 2 2	3 11 6	4 7 5	3 14 6	3 0 0
Jacket, double-breasted, diagonal serge, with gilt buttons for P.O.	2 19 0	3 0 11	3 10 6	4 5 11	3 13 6	2 19 6
Jacket, double-breasted, diagonal serge, with black horn buttons	2 16 6	3 0 0	3 9 6	4 4 8	3 12 6	2 19 0
Skirt, diagonal serge	1 6 0	0 19 10	1 16 11	1 2 6	1 8 6	1 4 5

5. The conditions of the contracts are as follows:—

(a) When ordering garments the rating must present to the contractor a written Authority, on Form A.S. 87x, signed by the relevant Supply Officer. Such Authority is to state the rating's name, official number, rating and establishment in which serving, and must specify in detail the articles and quantities thereof authorized to be purchased. Unless such an Authority, on Form A.S. 87x, containing full details is presented the order will not be accepted.

(b) The rating shall sign the order book of the contractor when placing order, and shall make an initial payment of at least five shillings. All orders must be paid for in cash on delivery.

(c) The garments ordered shall be made by the contractor to the measurement of the rating and shall be tried on at the contractor's premises at least once in the basted or unfinished condition and again in the finished state.

(d) The garments shall be made to the complete satisfaction of the rating, but shall conform to Service requirements and specifications held by the contractor.

(e) Completion of garments shall be effected within at least fourteen days from date of measurement of the rating or as otherwise arranged by mutual consent between the rating and the contractor, the delivery period being subject to the rating attending for try-on on the date specified by the contractor.

(f) Delivery of garments shall be taken at the contractor's premises or otherwise at the rating's expense.

6. In addition to the supply of personal requirements of made-to-measure garments, the contract provides for the supply of garments against official orders in circumstances where this may be necessary. In these instances the following conditions shall apply:—

(a) Orders shall be placed by Supply Officers on Treasury Form 21 accompanied by properly completed self-measurement form (if ratings are unable to attend for measurement) and Form N.A. 4.

(b) Garments shall be completed within fourteen days of receipt by the contractor of the Official order and delivered by parcels post to the address shown thereon, postal charges being to the account of the Establishment concerned.

(c) Unsatisfactory garments supplied against official orders shall be returned to the contractor to be altered to the complete satisfaction of the Ordering Officer, at the contractor's expense, including forwarding charges each way.

(434/216/113.)

(This Order will be reprinted for posting on Notice Boards.)

467.

CONTRACTS FOR SUPPLY OF RATINGS' MADE-TO-MEASURE UNIFORMS.

New contracts have been arranged in Melbourne, Sydney, Brisbane, Adelaide, Perth, and Hobart, with the following contractors, for the supply of ratings' made-to-measure uniforms for the period ending 30th June, 1946:—

Melbourne—Messrs. David Lack, Finlay's Buildings, cr. Little Lonsdale and Elizabeth streets.

Sydney— Messrs. David Jones Ltd., Marlborough-street, Surry Hills.

Brisbane— Messrs. Neville and McKay Pty. Ltd., Essex House, 217 Adelaide-street.

Adelaide— Messrs. C. M. Eatt, 113 Gawler-place.
Messrs. Ashford Clothing Co., 98 North Terrace.
Messrs. Reg. Habib, Dell's Buildings, Twin-street

Perth— Messrs. National Clothing Co. (1939) Ltd., 40 King-street.

Hobart—Messrs. Garretts Pty. Ltd., 102 Bathurst-street.

2. The uniform items to be supplied by each contractor and the prices (which are inclusive of the cost of all materials) are as follow:—

Description	Melbourne.	Sydney.	Brisbane.	All laid.			Per lb.	Hobart.
				C. M. Eatt.	Ashford Clothing Co.	Reg. Habib.		
Jackets, double-breasted, diagonal serge, with gilt buttons C.P.O.	£ s. d. 3 12 6	£ s. d. 3 3 6	£ s. d. 4 4 10	£ s. d. 4 19 6	£ s. d. 4 19 6	£ s. d. *	£ s. d. 4 6 0	£ s. d. 2 15 1
Jackets, double-breasted, diagonal serge, with gilt buttons I.O.	3 10 6	3 2 3	4 3 7	4 18 3	4 18 3	*	4 4 6	2 15 1
Jackets, double-breasted, diagonal serge, with horn buttons	3 7 6	3 1 4	4 3 2	4 17 3	4 17 3	*	4 3 6	2 13 3
Trowsers, diagonal serge, with fly	1 10 0	1 7 4	1 10 2	1 15 0	1 15 0	*	1 11 9	1 10 2
Jackets, single-breasted, seamen's serge, with gilt buttons C.P.O.	2 17 6	3 0 4	3 19 7	4 17 0	4 17 0	*	3 17 0	2 13 8
Jackets, single-breasted, seamen's serge, with gilt buttons P.O.	2 17 0	2 19 1	3 18 4	4 15 9	4 15 9	*	3 16 0	2 13 1
Jackets, single-breasted, seamen's serge, with horn buttons	2 14 0	2 18 2	3 17 4	4 15 0	4 15 0	*	3 15 3	2 11 10
Trowsers, seamen's serge, with fly	1 17 9	1 6 7	1 9 6	1 14 3	1 14 3	*	1 11 0	1 9 5
Trowsers, seamen's serge	1 15 0	1 8 3	*	1 16 10	*	*	1 15 6	1 6 4
Trowsers, seamen's serge, with fall	1 10 0	1 7 7	*	*	*	*	1 11 6	1 3 6
Ove coats, blue cloth with gilt buttons	4 6 6	4 13 5	*	2 0 6	*	5 5 0	5 0 0	4 16 3
Ove coats, blue cloth with horn buttons	4 5 0	4 11 4	*	*	*	5 3 0	4 18 0	4 15 9

* Not included. The only items to be supplied are those for which prices are shown.

3. The contracts have been arranged for the convenience of ratings who wish to purchase made-to-measure garments and particular attention is invited to the conditions set out in paragraph 4 (c). Ratings should insist on contractors observing the conditions, which provide for at least one try-on in the basted or unfinished condition, and a final try-on in the finished state, in order to ensure satisfactory fit.

4. The conditions of the contract are as follows:—

- (a) When ordering garments the rating must present to the contractor a written Authority, on Form A.S. 87x, signed by the Supply Officer of his ship if one is borne, otherwise by the Commanding Officer or an Officer delegated by him. Such Authority is to state the rating's name, official number, rating, ship, or establishment in which serving and must specify in detail the articles and quantities thereof authorized to be purchased. Unless such an Authority on Form A.S. 87x containing full details is presented, the order will not be accepted.
- (b) The rating shall sign the order book of the contractor when placing order, and shall make an initial payment of at least five shillings. All orders must be paid for in cash on delivery.
- (c) The garments ordered shall be made by the contractor *to the measurements of the rating and shall be tried on at the contractor's premises at least once in the basted or unfinished condition and again in the finished state.*
- (d) The garments shall be made to the complete satisfaction of the rating, *but shall conform to Service requirements and specifications held by the contractor.* Certain extras are permissible and are as follows:—

	Extra Charges.		
	Neville and McKay Pty. Ltd., Brisbane.	David Jones Ltd., Sydney.	All Other Contractors.
	<i>s. d.</i>	<i>s. d.</i>	<i>s. d.</i>
<i>Classes I and III.</i>			
Extra inside pocket in single-breasted jackets	1 0	0 9	0 9
Hip pockets	1 3	1 3	1 3
Extension bands and pleats	1 0	1 10	0 9
Leather binds on trouser bottoms	0 3	0 8	0 3
		each	
Sewing on of badges and chevrons	0 9	0 9	0 9
Fob pocket	1 0	1 0	1 0
Trousers, fly, with straight tops, fitted with loops for belt	No extra charge involved		
<i>Class II.</i>			
Sewing on of badges and chevrons, emblems		0 9	0 9
		each	
Zipp fasteners (if stocks held by contractors)		*2 0	2 3
Taping of bottoms of trousers, fall, with dark material to tone with serge		1 1	0 6

* The Sydney contractor's price is for attaching only.

- (e) Completion of garments shall be effected within at least fourteen days from date of measurement of the rating or as otherwise arranged by mutual consent between the rating and the contractor, the delivery period to be subject to the rating attending for "try-on" on the date specified by the contractor.
- (f) Delivery of garments shall be taken at the contractor's premises or otherwise at the rating's expense.

5. In addition to the supply of personal requirements of made-to-measure garments, the contract provides for the supply of garments against official orders in circumstances where this may be necessary. In these circumstances the following conditions shall apply:—

- (a) Orders shall be placed by Supply Officers on Treasury Form 21 accompanied by properly completed self-measurement form (if ratings are unable to attend for measurements) and Form N.A. 4.
- (b) Garments shall be completed within fourteen days of receipt by the contractor of the official order and delivered by parcels post to the address shown thereon, postal charges being to the account of the Ship or Establishment concerned.
- (c) Unsatisfactory garments supplied against official orders shall be returned to the contractor to be altered to the complete satisfaction of the Ordering Officer, at the contractor's expense, including forwarding charges each way.

(434/216/113.)

(This Order will be reprinted for posting on Notice Boards.)

468.

RE-ESTABLISHMENT OF H.M.A. NAVAL VICTUALLING DEPOT, DARWIN.

A Victualling Depot has been re-established at Darwin for the purpose of supplying requirements of Victualling Stores to H.M.A.S. *Melville* and H.M.A. Ships based on that port.

2. Demands for requirements should be lodged with the Officer-in-Charge, H.M.A. Naval Victualling Depot, Darwin.

3. The requirements of ships, other than those indicated in paragraph 1, which may visit Darwin from time to time can only be met to a very limited extent unless notice is given well in advance of the anticipated date of arrival.

(612/248/1535.)

By Authority: H. E. DAW, Government Printer, Melbourne.

RESTRICTED.

(FOR OFFICIAL USE ONLY.)

Commonwealth Navy Order.

Navy Office, Melbourne,
16th October, 1945.

The following Order, having been approved, is hereby promulgated for information and guidance and necessary action.

By direction of the Naval Board,

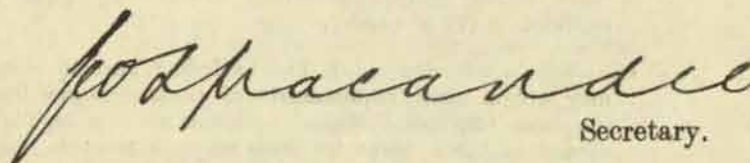
Secretary.

*The Commodore Commanding H.M.A. Squadron,
and Commanding Officers of H.M.A. Ships,
Officers in Charge of H.M.A. Naval
Establishments, and others concerned.*

TABLE OF CONTENTS.

No.	Subject.
469.	Canteen Arrangements in H.M.A. Ships and Naval Establishments— Consolidation.

C.9975/45.

459.

CANTEEN ARRANGEMENTS IN H.M.A. SHIPS AND NAVAL ESTABLISHMENTS—CONSOLIDATION.

During the present war it has been necessary to depart substantially from established Naval canteen procedure prescribed in regulations, instructions and standing orders, and existing arrangements, as promulgated in Navy Orders 484, 599, and 618 of 1944, Navy Order 34 of 1945, and Naval Board general signal No. 090523 July, 1945, are consolidated hereunder for ready reference and close observance by all ships and establishments concerned:—

A. SERVICE SYSTEM CANTEENS.

- (i) The Australian Army Canteens Service maintains regular supplies of canteen stores to all Service System Canteens in Naval Establishments which are, as a standing principle, to demand their requirements of canteen stores from the most convenient A.A.C.S. Issuing Point (a list of issuing points concerned is shown as an Appendix to this Order), obtaining supplies from other sources only in case of emergency. Where it is desired, however, to include in canteen stocks an article (apart from a different brand only) of a nature not normally held in A.A.C.S. stocks, supplies may be drawn direct from a manufacturer or merchant or, in the case of shore bases in the islands North of Australia, from a Victualling Store Issuing Ship, the selling price being fixed as provided in (v) hereunder.
- (ii) Canteens in seagoing ships, but excluding harbour ships, may obtain their requirements of canteen stores from the most convenient source. Such stores are regularly carried in V.S.I. Ships for issue on repayment to ships in Northern operational areas and, in addition, supplies will be available to those canteens from A.A.C.S. Issuing Points to the extent that stocks permit. In the case of controlled items and items in short supply, e.g., cigarettes and tobacco, it may be necessary, temporarily, for seagoing ships to obtain requirements at mainland ports from A.A.C.S. Issuing Points. Selling prices are to be regulated by the Canteen Committee in accordance with K.R. and A.I., Article 630, clause 6.
- (iii) Stores supplied to Service System Canteens, both ashore and afloat, by A.A.C.S. will be charged at that organization's retail prices operating in the area of supply, less a discount of 5 per cent. At Brisbane, Sydney, Melbourne, Adelaide, and Fremantle, bonded stores supplied to seagoing ships will, however, be charged at cost prices only, plus 2½ per cent. All supplies by A.A.C.S. will be made on a strictly cash basis.

- (iv) In addition to the 5 per cent. discount referred to in sub-paragraph (iii), a rebate of 5 per cent. on the amount of the total purchases of all Service System Canteens, excluding purchases of bonded stores at the ports named in sub-paragraph (iii), is paid monthly to Navy Office by the Central Canteens Control Board, and is accompanied by a schedule showing the amount due in respect of the monthly purchases of each ship and establishment. One-third of this rebate is paid to the credit of the R.A.N. Central Canteen Fund, the functions of which are set out in Section D hereunder, while the balance is paid, through Supply Officers, to the individual ships and establishments concerned where officially authorized canteens operate.
- (v) Supplies obtained from A.A.C.S. by shore-based canteens are invariably to be sold to ship's companies at the prices shown in the current A.A.C.S. Retail Price List for the area of supply, copies of which should be obtained from the local A.A.C.S. representative. Where supplies are drawn from sources other than A.A.C.S., as provided in sub-paragraph (i) above, the selling prices are to be regulated by the Canteen Committee in accordance with K.R. and A.I., Article 630, clause 6.
- (vi) C.O.R., Articles 454 and 455 (clause 2), provide that Naval Board approval is necessary to the establishment of a canteen in any H.M.A. Ship or Establishment, or other place used exclusively by Naval personnel. This approval is necessary whether or not an advance from public funds is desired in accordance with Naval Account Regulations and Instructions, Article 61. Any ship or establishment in which a Service System Canteen is at present operating without specific Naval Board approval, other than A.M.S. Vessels and Frigates in which the establishment of a canteen has been approved by a Naval Officer-in-Charge under authority delegated by the Naval Board, is therefore to report the matter to Navy Office forthwith for covering approval.
- (vii) Naval Officers-in-Charge and Port Directors are required to co-operate with the local representatives of A.A.C.S., who are to be furnished with such information as is necessary in order to ensure the maintenance locally of adequate stocks to meet known and anticipated requirements of Naval canteens on shore, a similar procedure being observed in the event of a sea-going ship requiring replenishment from A.A.C.S. sources.
- (viii) In ships and establishments with Service System Canteens, the general procedure prescribed in K.R. and A.I., Article 632, is to apply wherever a Supply Officer is borne, except that half-yearly reports are to be forwarded to Navy Office as at 30th June and 31st December.

The following modified instructions are, however, to be strictly observed in all cases where a Supply Officer is not borne :—

(a) *Canteen Rules.*

The Captain shall cause proper rules to be drawn up for the conduct and administration of the canteen.

(b) *Canteen Committee.*

The composition of the Canteen Committee is to be based, as far as the complement permits, on the general principle enumerated in K.R. and A.I., Article 630, clause 2, and the Executive Officer is always to act as ex-officio president.

(c) *Duties of Canteen Committee.*

Subject to (a) above, and the instructions contained in sub-paragraph (i) to (v) of this section, the Canteen Committee is responsible for the general administration of all matters relating to the canteen and for the administration of the Ship's Fund.

(d) *Ship's Fund.*

The profits of the canteen are to be paid to the Ship's Fund, which is to be utilized and controlled as provided in K.R. and A.I., Article 630, clause 4.

(e) *Prices.*

A list of prices authorized in accordance with sub-paragraphs (i), (ii), and (v) of this section is to be displayed prominently in or near the canteen.

(f) *Canteen Attendants.*

Canteen attendants may be paid such remuneration for their services as may be decided by the Canteen Committee and approved by the Captain.

(g) *Periodical Audit of Accounts and Stocktaking.*

The accounts of the canteen are to be audited and the stock checked by at least two representatives of the Committee detailed for the purpose by the Captain. These operations are to be carried out at the end of each quarter and at least on one other occasion during the quarter without notice. A record of such examinations is to be maintained on board, which is to be inspected by the Supply Officer of the parent ship at every opportunity.

(h) *Custody of Money.*

The Captain is to ensure that satisfactory arrangements are made for the custody of canteen money. Where practicable, a banking account should be opened for the purpose and be operated upon by at least two members of the Canteen Committee, one of whom is to be the Executive Officer. Moneys retained on board, except such as may be necessary for change purposes in the canteen, are to be kept in the possession of an officer, and a suitable record maintained of all sums received and issued, against which signatures are to be recorded.

(i) *Security of Canteen Stores.*

The Captain is to ensure that suitable lock-up accommodation is provided for the safety of canteen stores.

(j) *Half-Yearly Report and Balance Sheet.*

A report on the operation of the canteen is to be forwarded to the Director of Victualling on 30th June and 31st December of each year, also on paying off. This report is to be accompanied by a certified copy of the balance sheet on those dates. The persons certifying to the correctness of the balance sheet should be the representatives of the Canteen Committee referred to in sub-paragraph (g) above, and the valuation of unsold stock is to be calculated at cost prices.

B. CANTEENS CONDUCTED BY A.A.C.S.

- (i) In Naval Establishments where canteens are wholly conducted by A.A.C.S., a monthly rebate of 5 per cent. on total retail sales is paid to Navy Office and is distributed in the same manner as provided in Section A (iv) above, viz., one-third is paid to R.A.N. Central Canteen Fund and the balance to the individual establishment concerned, through the Supply Officer.
- (ii) Any complaint which may arise in connexion with the normal operation of any one of these canteens, either in respect of stocks or service, is to be investigated by the Commanding Officer who, if necessary, will represent the matter to the local District Board of A.A.C.S., a copy of any communication being forwarded to the Naval Board for information and further action, if considered desirable, with the Central Canteens Control Board, through the Department of the Army.

C. TENANT CANTEENS.

- (i) A.A.C.S. will, when so requested, assist canteen tenants in H.M.A. Ships in procuring their requirements of stores. Where these are drawn from A.A.C.S. Issuing Points, the basis of charge will be as provided in Section A above.
- (ii) In order that seagoing ships with canteen tenants may participate in contributing to the Central Canteen Fund, the scale of canteen rentals shown in C.O.R., Article 455, was increased by 25 per cent. as from 1st October, 1944, the whole of such increase being paid by Supply Officers in the ships concerned to the credit of the Central Fund at the end of each quarter.

D. R.A.N. CENTRAL CANTEEN FUND.

- (f) The Naval Board have established a special fund known as the R.A.N. Central Canteen Fund, the functions of which are—
- (a) to provide amenities of a general nature beyond the capacity of an individual ship or establishment;
- (b) to contribute the Navy share to certain special funds (not of Government origin) now used to supplement the Government scheme for education of children of deceased or disabled servicemen; and
- (c) to promote the welfare of Naval or ex-Naval personnel in any other manner which the Naval Board may approve.
- (ii) The Central Canteen Fund is partly financed, as indicated in sub-paragraphs A (iv), B (i), and C (ii) above, by a general levy in all H.M.A. Ships and Establishments on funds normally obtainable from canteen sources and credited to the Ship's Fund; also partly from a small levy on the value of bulk canteen stores maintained in V.S.I.S's. for issue on repayment to ships and island bases, and from profits made on bulk issues of bottled beer maintained in V.S.I.S's. for issue to ships' companies.
- (iii) Information regarding the composition of the Central Canteen Fund Committee, the general method of administration of the Central Fund, &c., will be promulgated separately in Navy Orders at an early date.

E. USE OF ARMY HOSTELS AND OFFICERS' CLUBS BY NAVAL PERSONNEL.

The Department of the Army extends the full use of A.A.C.S. Hostels and Officers' Clubs to Naval personnel, available sleeping accommodation being apportioned between Naval and Army personnel having regard to the strengths of the respective Services in each locality concerned.

APPENDIX.

Australian Army Canteens Service Issuing Points at which bulk supplies will be available for Naval purposes.

Borneo—	Northern Territory—
Balikpapan.	Darwin.
Labuan.	Adelaide River.
Bougainville—	Queensland—
Green Island.	Brisbane.
Emirau Island.	Maryborough.
Torokina.	Townsville.
Moluccas—	Cairns.
Morotai.	Thursday Island.
New Britain—	South Australia—
Jacquinot Bay.	Adelaide.
New Guinea—	Tasmania—
Port Moresby.	Hobart.
Lae.	Launceston.
Madang.	Victoria—
Wewak.	Melbourne.
New South Wales—	Flinders Naval Depot.
Sydney.	Western Australia—
Wollongong.	Perth.

2. Navy Orders 484, 599, and 618 of 1944, and Navy Order 34 of 1945 are hereby cancelled.

(427/201/909).

(This Order will be reprinted for posting on notice boards.)

RESTRICTED.

(FOR OFFICIAL USE ONLY.)

Commonwealth Navy Order.

Navy Office, Melbourne,

16th October, 1945.

The following Order, having been approved, is hereby promulgated for information and guidance and necessary action.

By direction of the Naval Board,

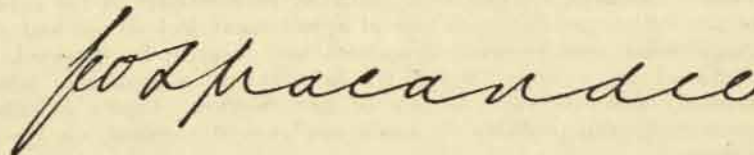

Secretary.

*The Commodore Commanding H.M.A. Squadron,
and Commanding Officers of H.M.A. Ships,
Officers in Charge of H.M.A. Naval
Establishments, and others concerned.*

TABLE OF CONTENTS.

No.	Subject.
470.	Post War Opportunities in His Majesty's Colonial Service.

470.

POST WAR OPPORTUNITIES IN HIS MAJESTY'S COLONIAL SERVICE.

Hostilities having now ceased, recruitment to the Colonial Service is re-opening on a considerable scale. The following arrangements have been made for the submission of applications by Australian candidates who are now serving in or have been discharged from the Australian Forces.

2. The principal appointments are for Administrative, Agricultural, Education, Engineering, Forestry, Medical, Police, and Veterinary Officers. There are Medical, Nursing, Educational, and a limited number of other posts open to women. Short particulars of the age limits, qualifications required, salaries, &c., are given in the Appendix to this Order.

3. Attention is particularly drawn to the qualifications described in the Appendix for each of the various classes of appointments.

Candidates who do not possess the qualifications mentioned will be wasting time in applying for further particulars.

4. Further particulars of the post-war opportunities in the Colonial Service and of the arrangements which are being made for post-war recruitment are given in a leaflet issued by the Colonial Office, marked R.D.W. 6. More detailed information about the various classes of appointments, including such matters as the nature of the duties, general conditions of appointment and service and the geographical area in which vacancies may usually be expected, is contained in a series of official Recruitment memoranda, which severally describe each branch of the Service. Copies of these memoranda can probably be made available, if required, on special enquiry.

5. Intending candidates who appear to possess the required qualifications should write to the Director-General of Manpower (Scientific Personnel Section), Herald Building, 66 Pitt-street, Sydney, N.S.W., and ask for a copy of the Colonial Office leaflet R.D.W. 6 and the appropriate application form. In their letter they should state for which branch or branches of the Colonial Service they wish to apply, and they should give a brief statement of their qualifications.

6. Service or ex-service personnel desiring to be considered under these special arrangements must **before 30th November, 1945**, indicate to the Director-General of Manpower, as explained in paragraph 5, their intention to apply for a Colonial Service appointment.

7. In order to expedite as much as possible the lodging of applications, applicants are advised to request those who write testimonials in support of their applications to send testimonials direct to the Director-General of Manpower (Scientific Personnel Section), at the address above. The two confidential referees named by each applicant will be communicated with by the Director-General on receipt of the application.

8. Application forms should be filled in with special attention to the marginal notes, and after completion should be returned to the Director-General of Manpower (Scientific Personnel Section) at the address above.

9. There is no written examination and no entrance fee. Candidates will be selected, as in peace time, by competitive selection based on record and (where considered *prima facie* suitable) personal interview.

10. Suitable applications will be submitted for consideration to Selection Committees which have been set up in each State of the Commonwealth. Applications recommended by a State Committee will be further considered by an Australian Selection Committee. Applications recommended by this Committee will be transmitted to the Colonial Service Appointments Board in London, which advises the Secretary of State.

11. The arrangements set out in this Order will replace, so far as Australian Service applications are concerned, any inconsistent provisions in R.D.W. 6, in Recruitment memoranda, or in the application form supplied.

APPENDIX.

*Summary of principal appointments dealt with by—
The Director of Recruitment (Colonial Service).*

The particulars given in this summary relate to the pre-war regulations with the exception of the age limits. The present minimum limit (20½) is common to all appointments. The present maximum is shown below for each class of appointment.

The following points should also be noted:—

- (a) In addition to the salaries shown, free quarters (or allowances in lieu,) free passages and free medical attendance are in most cases provided.
- (b) Above the salary scales there are higher posts, which are filled by promotion inside the Service. Some indication of the nature and range of such posts is given under the various headings below. Colonial Governorships, carrying salaries and allowances amounting to as much as £8,000 a year in some cases, are also normally filled by promotion from the Colonial Service.
- (c) "Areas" denotes those areas in which vacancies may occur to be filled by new entrants to the Service. Vacancies may occur elsewhere to be filled by promotion or transfer inside the Service.

The Colonial Administrative Service.

(Recruitment Memorandum No. 2).

Age.—Candidates must have been born on or after the 1st January, 1910.

Qualifications.—High standard of general education, intellectual ability, leadership, character, physique, University education (Honours) generally desirable, but not indispensable.

Salary.—Initial salary from £350 to £490, on scales rising to £1,000 or £1,400. Super-scale posts in District Administrations and the Secretariats ranging from Deputy Provincial Commissionerships to Colonial Secretaryships, at salaries varying from £1,100 to £3,000.

Areas.—Mainly West and East Africa: Malaya, Hong Kong, Ceylon, Fiji, and Western Pacific: Palestine, Cyprus, Aden; occasionally Basutoland, Bechuanaland, Swaziland. *Not* West Indies.

N.B.—The Description of the duties of an Administrative Officer given in Recruitment Memorandum No. 2 applies particularly to the present pre-war functions of the Administrative Service. In future, however, Administrative Officers will be required in increasing numbers to undertake more specialized duties as the technique of Colonial Administration develops and the range of governmental activities in the Colonies increases. In particular, they may be required to undertake duties in connexion with public relations, economic policy, labour, the co-operative movement, demographic surveys, industry, commerce, &c. Candidates, therefore, who are interested in and possess qualifications for these branches of administration may hope, if selected, to find increasing opportunities of specialization.

The Colonial Agricultural Service.

(Recruitment Memorandum No. 4.)

Age.—Candidates must have been born on or after the 1st January, 1905.

Qualifications.—A University Degree in Agriculture, or Natural Science, Candidates are considered in the first instance for post-graduate Colonial Agricultural Scholarships involving two years further training, partly overseas, in General Agriculture or in specialist subjects (e.g., Botany, Entomology, Chemistry). Holders of these Scholarships form a pool from which vacancies are filled.

Salary.—Initial salary from £400 to £560 on scales rising to £840 or £1,120. Scholarships worth £200 (home) or £225 (abroad) with fees and overseas passages paid. Super-scale posts for Senior Agricultural Officers, Directors and Deputy Directors of Agriculture at salaries of up to £1,750.

Areas.—Mainly East and West Africa; Malaya; occasionally West Indies, rarely elsewhere.

The Colonial Audit Service.

(Recruitment Memorandum No. 2.)

Age.—Candidates must have been born on or after the 1st January, 1910.

Qualifications.—In general as for the Administrative Service, with a natural inclination for figures and accounts.

Salary.—Initial salary from £350 to £400 on scales rising to £920. The Directorship of Colonial Audit and other super-scale posts at salaries ranging from £960 to £1,700.

Areas.—Various.

The Colonial Customs Service.

(Recruitment Memorandum No. 8.)

Age.—Candidates must have been born on or after the 1st January, 1910.

Qualifications.—High standard of general education and personal qualities. School Certificate, or approved equivalent, regarded as minimum educational qualifications.

Salary.—Initial salary from £350 to £420 on scales rising to £780 or £1,120. Super-scale posts at salaries ranging up to £1,680.

Areas.—Mainly Malaya. Very rarely elsewhere.

The Colonial Education Service.

(Recruitment Memorandum No. 5.)

Age.—Candidates must have been born on or after the 1st January, 1905.

Qualifications.—For immediate appointment—University degree (usually Honours) and Education Diploma or equivalent. For Education Probationers—University degree, to be followed by special Diploma training course at London University Institute of Education.

Salary.—Initial salary from £350 to £360 on scales rising to £840 or £1,120. Probationers receive £20 a month during course. Super-scale posts, both administrative and specialist at salaries ranging up to £1,780.

Areas.—Mainly East and West Africa; Malaya, Hong Kong; occasionally West Indies, Mauritius and elsewhere.

The Colonial Engineering Service and Appointments for Architects and Town Planners.

(Recruitment Memorandum No. 10.)

Age.—Candidates must have been born on or after the 1st January, 1905.

Qualifications.—(1) *Civil Engineers.*—Corporate Membership of the Institution of Civil Engineers, or an Engineering Degree or Diploma recognized as granting exemption from Sections A and B of the Associate Membership of the Institution of Civil Engineers, and two years' practical experience.

(2) *Mechanical Engineers.*—

(i) Railways—Engineering Degree or Associate Membership of the Institute of Mechanical Engineers and apprenticeship in locomotive works, with subsequent practical experience in railway running, department or works management.

(ii) Public Works—Engineering Degree or Associate Membership of the Institute of Mechanical Engineers and apprenticeship with subsequent experience of engines.

(3) *Electrical Engineers.*—Electrical Engineering Degree or Associate Membership of the Institution of Electrical Engineers, and apprenticeship with subsequent power station and mains experience, and in the case of Telegraph Engineers, thorough training in telegraph and telephone engineering, with experience in a Post Office Engineering Department or on a British Railway.

N.B.—During the Reconstruction period, candidates may apply who (a) possess an Engineering Degree or Diploma, but have been prevented by war service from obtaining practical experience, or (b) have no academic qualifications, but have during their war service obtained extensive experience of engineering practice.

(4) *Architects.*—Associateship of the Royal Institute of British Architects or an equivalent qualification in a Dominion, with experience of the general work of an architect's office.

(5) *Town Planners.*—Final Examination of the Town Planning Joint Examination Board or its equivalent, and experience of all stages of the technique of the Town Planner.

Salary.—Initial salary from £450 on scales rising to between £840 and £1,120. Super-scale posts for Engineers exist at salaries ranging from £1,050 to £1,800 per annum. Architects and Town Planners are occasionally engaged as Consultants.

Areas.—Various.

The Colonial Forest Service.

(Recruitment Memorandum No. 4).

Age.—Candidates must have been born on or after the 1st January, 1905.

Qualifications.—A University Degree in Forestry. There are also post-graduate scholarships in forestry for candidates with other degrees, usually Honours in Natural Science including Botany, tenable at the Imperial Forestry Institute, Oxford, for one year in the first instance.

Salary.—Initial salary usually from £400 to £560 on scales rising to £840 or £1,120. Super-scale posts for Conservators and Senior Assistant Conservators at salaries ranging up to £1,600.

Areas.—Mainly East and West Africa; Malaya; sometimes West Indies.

The Colonial Legal Service.

(Recruitment Memorandum No. 5).

Age.—Candidates must have been born on or after the 1st January, 1905.

Qualifications.—A Barrister or Solicitor with not less than four years professional experience since Call or Admission. (The majority of appointments are for barristers.)

Salary.—Initial salary usually £600 (with increments for experience in some cases) on scales rising to £840, £1,000 or £1,400. Super-scale posts for Judges and Senior Law Officers at salaries ranging up to £2,500.

Areas.—Various.

The Colonial Medical Service.

(Recruitment Memorandum No. 3).

Age.—Candidates must have been born on or after the 1st January, 1905.

Qualifications.—A medical qualification registrable in the United Kingdom. Preference for candidates who have held hospital or public health appointments.

Salary.—Initial salary from £600 to £700 on scales rising to £1,000 or £1,120. Super-scale posts, both administrative and specialist, e.g., Pathologists, Bacteriologists, Surgeons, Radiologists, Anaesthetists, Senior Health Officers. Salaries ranging from £1,150–£2,000.

Areas.—Mainly East and West Africa and Malaya.

N.B.—There are also vacancies for Dental Surgeons.

The Colonial Police Service.

(Recruitment Memorandum No. 8).

Age.—Candidates must have been born on or after the 1st January, 1910.

Qualifications.—High standard of general education and personal qualities. School Certificate, or approved equivalent regarded as minimum educational qualification.

Salary.—Initial salary usually £350 to £420 on scales rising to £760 or £1,120. Super-scale posts at salaries up to £1,680.

Areas.—Mainly Malaya and East and West Africa.

The Colonial Survey Service.

(Recruitment Memorandum No. 7).

Age.—Candidates must have been born on or after the 1st January, 1910.

Qualifications.—An Honours Degree in Mathematics, Physics, Civil Engineering or Geography (including Geodetic and Trigonometrical Survey) or certain equivalent qualifications.

Salary.—Initial salary from £400 to £560 on scales rising to £840 or £1,120. Super-scale posts at salaries ranging up to £1,680.

Areas.—Mainly East and West Africa; Malaya; occasionally Hong Kong, rarely elsewhere.

The Colonial Veterinary Service.

(Recruitment Memorandum No. 4).

Age.—Candidates must have been born on or after the 1st January, 1905.

Qualifications.—Diploma of Membership of Royal College of Veterinary Surgeons, or veterinary qualification obtained in one of the Dominions. Candidates are normally considered in the first instance for a Colonial Veterinary Studentship involving at least one year's further training in this country. Holders of these Studentships form a pool from which vacancies are filled.

Salary.—Initial salary usually from £560 to £630 on scales rising to £840 or £1,120. Studentships worth £300. Super-scale posts ranging up to £1,470.

Areas.—Mainly East and West Africa; Malaya; occasionally West Indies, rarely elsewhere.

The Colonial Chemical, Geological Survey and Mining Services, and Meteorological Appointments.

(Recruitment Memorandum Nos. 4 and 7).

There are also a comparatively small number of appointments in the above branches of the Service for candidates with appropriate academic or professional qualifications in Analytical Chemistry (Memorandum No. 4), and in Geology, Metalliferous Mining and Meteorology (Memorandum No. 7).

Age.—Candidates for these appointments must have been born on or after the 1st January, 1905.

Labour Appointments.

(Recruitment Memorandum No. 11).

Age.—Candidates must have been born on or after the 1st January, 1905.

Qualifications.—Sufficient practical experience of labour administration in the United Kingdom to qualify the candidate for a post as Industrial Adviser, or Labour Officer responsible for negotiation and arbitration work, in a colony; alternatively, sufficient experience of the control and management of native labourers (including a knowledge of local language) to be able to undertake supervision and inspection of conditions of work in a colony.

Salary.—Dependent on qualifications, but at least comparable to salaries paid in Great Britain for corresponding work.

Areas.—Most parts of the Colonial Empire, but mainly in Africa.

Social Welfare Appointments.

(Recruitment Memorandum No. 11).

Age.—Candidates must have been born on or after the 1st January, 1905.

Qualifications.—Sufficient practical experience in one or more branches of social welfare work to qualify the candidate for a senior post such as Social Welfare Organizer to a Colonial Government, or as a Social Welfare Supervisor. A Social Science Diploma or Certificate may also be required.

Salary.—Dependent on qualifications, but at least comparable to salaries paid in Great Britain for corresponding work.

Area.—Mainly Tropical Africa.

APPOINTMENTS FOR WOMEN.

(a) *Colonial Education Service.*

(Recruitment Memorandum Nos. 5 and 9).

Age.—Candidate must have been born on or after the 1st January, 1905.

Qualifications.—A recognized teaching qualification and subsequent practical experience. Qualifications in domestic subjects and experience of teaching young children are often required, and a university degree is sometimes essential.

Salary.—Initial salaries usually from £330 to £420 in scales rising to various points between £600 and £840.

Area.—Mainly East and West Africa, Malaya, and Hong Kong, occasionally West Indies and elsewhere.

(b) *The Colonial Medical Service.*

(Recruitment Memorandum Nos. 3 and 9).

Age.—Candidates must have been born on or after the 1st January, 1905.

Qualifications.—A medical qualification registrable in the United Kingdom. A preference for candidates who have held hospital appointments. Experience in child welfare and maternity work or in preventive medicine is very desirable.

Salary.—Initial salary from £600 to £700 on scales rising to £1,000 or £1,120.

Areas.—Malaya and East and West Africa.

(c) *The Colonial Nursing Service.*

(Recruitment Memorandum No. 9).

Age.—Candidates must have been born on or after the 1st January, 1905.

Qualifications.—A general nursing qualification registrable in the United Kingdom. The certificate of a State Certified Midwife or the First Certificate of the Central Midwives Board essential, except for a few specialist posts. Occasional vacancies for Sister Tutors, or for Nurses with qualifications in public health, mental nursing, and radiography.

Salary.—Initial salary £240 or £350 on scales rising to £300 or £480.

Areas.—Mainly East and West Africa and Malaya.

(d) *Administrative and Social Welfare Appointments.*

(Recruitment Memorandum No. 9).

See particulars already given of Social Welfare Appointments. Opportunities also occur from time to time for women with university degrees and/or practical administrative experience to be considered for Secretariat and other posts in the Colonies. Women Typists and Clerks, on the other hand, are generally appointed locally.

(404/201/694.)

(This Order will be reprinted for posting on Notice Boards.)

...the ... of ...

...the ... of ...

...the ... of ...

...the ... of ...

...the ... of ...

...the ... of ...

...the ... of ...

...the ... of ...

...the ... of ...

...the ... of ...

RESTRICTED.(FOR OFFICIAL USE ONLY.)

Commonwealth Navy Orders.

Navy Office, Melbourne,
23rd October, 1945.

The following Orders, having been approved, are hereby promulgated for information and guidance, and necessary action.

By direction of the Naval Board,

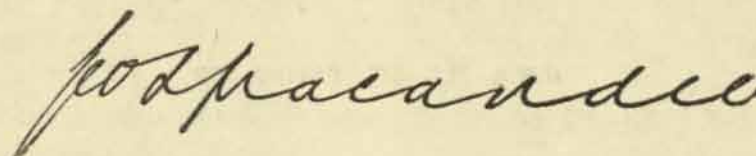

Secretary.

*The Commodore Commanding H.M.A. Squadron,
and Commanding Officers of H.M.A. Ships,
Officers in Charge of H.M.A. Naval
Establishments, and others concerned.*

TABLE OF CONTENTS.

No.	Subject.
471.	H.M.A. G.P.V. 960—Commissioning.
472.	H.M.A. M.L. 806—Paying off.
473.	H.M.A. M.L. 817—Paying off.
474.	H.M.A. H.D.M.L. 1161—Paying off.
475.	H.M.A.S. "Lucy Star"—Paying off.
476.	Port Directorate—Merauke.
477.	Degaussing Ranges.
478.	Acting Q.R.I's (S/V).
479.	Radar—Carbon Pile Regulators, Patt. W.1698 and W.2194—Ventilation.
480.	Fire-Fighting—Provision of Applicators—"Platypus", "Stuart", Frigates, Sloops, L.S.I's and A.M.S. Vessels.
481.	Naval Stores—Prevention of Misappropriations, Losses, &c.
482.	Service System Canteens—Rendition of Reports on Paying off.
483.	Procedure for Dealing with Victualling Stores in Tenders Paying off as a Result of General Demobilization.
484.	Kit Bags, Hammocks, &c.—Losses during Transport—Labelling and Marking.
485.	Honorary Membership of Golf Clubs—Victoria.

471.

H.M.A. G.P.V. 960—COMMISSIONING.

H.M.A. G.P.V. 960 was commissioned on 5th October, 1945.
(603/246/5428.)

472.

H.M.A. M.L. 806—PAYING OFF.

H.M.A. M.L. 806 was paid off into reserve on 10th October, 1945.
(603/294/1516.)

473.

H.M.A. M.L. 817—PAYING OFF.

H.M.A. M.L. 817 was paid off into reserve on 10th October, 1945.
(603/294/1516.)

474.

H.M.A. H.D.M.L. 1161—PAYING OFF.

H.M.A. H.D.M.L. 1161 was paid off into "F" class reserve on 5th October, 1945.
(603/297/641.)

475.

H.M.A.S. "LUCY STAR"—PAYING OFF.

H.M.A.S. *Lucy Star* was paid off on 6th October, 1945.
(603/246/5322.)

476.

PORT DIRECTORATE—MERAUKE.

The Port Directorate at Merauke was taken over from the Royal Australian Navy by the Royal Netherlands Navy on 1st October, 1945, and the appointment of the Naval Officer-in-Charge, Merauke, was terminated on that date.

(1937/2/316.)

477.

DEGAUSSING RANGES.

Degaussing ranges will close down in Australian ports on the following dates:—

Brisbane channel and loop ranges	..	15th October, 1945.
Fremantle deep and shallow open ranges		31st October, 1945.
Sydney deep and shallow open ranges		30th November, 1945.
Darwin open range	30th November, 1945.

(2026/25/187.)

478.

ACTING Q.R.I's (S/V).

The non-substantive rating of Acting Q.R.I. (S/V) may be granted to Chief Petty Officers, Petty Officers, or Leading Seamen carrying out the duties of Gunnery Instructors at:—

- (a) Gunnery Instructional Centres.
- (b) D.E.M.S. Centres.
- (c) Shore Establishments where employed as Gunnery Instructors owing to the shortage of Gunners' Mates.

The badge to be worn is that of a Q.R.I.

2. Acting Q.R.I's (S/V) are eligible for the non-substantive rate and pay of 1s. 6d. per diem:—

- (i) If they have completed successfully a special Instructors' Course at the R.A.N. Gunnery School, Flinders Naval Depot, and passed an examination for which they have been granted a certificate, and while carrying out the duty of a Gunnery Instructor or Gunner's Mate allowed on complement.
- (ii) With the approval of the Naval Officer-in-Charge, on the recommendation of the Gunnery Officer, while carrying out the duty of Gunnery Instructor or Gunner's Mate allowed on complement without possessing the certificate from the Gunnery School. The names of these ratings should be reported to the Naval Officer-in-Charge, Flinders Naval Depot, so that they can be drafted in for course when reliefs are available.
- (iii) When allocated to a specific duty which is considered to justify the non-substantive rate of Q.R.I., approval to rate and pay is, in this case, to be obtained from the Naval Board.

3. The non-substantive pay of 1s. 6d. per diem is not payable concurrently with other gunnery allowances or training allowances.

4. The non-substantive rating of Acting Q.R.I. (S/V) may be granted to ratings qualified in accordance with paragraph 2 above, with retrospective effect to 1st July, 1943, but not earlier.

5. The grant of the non-substantive rating of Acting Q.R.I. (S/V) and date of ceasing to be employed as such in a vacancy in complement are to be reported on Form A.S. 161 in every case.

6. Naval Officers-in-Charge of the activities referred to in paragraph 1 of this Order are to forward to Navy Office, as early as practicable, lists of ratings eligible and recommended for payment as Acting Q.R.I. (S/V) together with qualifying periods of service from 1st July, 1943 to 30th June, 1945, in order that authority for payment of arrears of the allowance may be issued. Payment of the allowance from 1st July, 1945, is to be effected strictly in accordance with paragraph 2 of this Order.

7. Navy Order 267 of 1945 is cancelled.

(349/25/370.)

(This Order will be reprinted for posting on Notice Boards.)

479.

RADAR—CARBON PILE REGULATORS, PATT. W.1698 AND W.2194 - VENTILATION.

Carbon Pile Regulators, Patt. W.1698 and W.2194 are fitted in certain types of control boards used with British Radar Equipment.

2. It has been found that these are unreliable due to overheating. It is necessary, therefore, to fit a source of air supply to provide cooling. This is to consist of a 2-inch trunk from the nearest source of air supply.

3. Ships concerned are to insert a defect item in their next list as follows:—

“To fit 2-inch forced ventilation supply to Carbon Pile Regulators situated (state location).”

(603 217 1909.)

480.

FIRE-FIGHTING—PROVISION OF APPLICATORS—“PLATYPUS”, “STUART”, FRIGATES, SLOOPS, L.S.I.'s AND A.M.S. VESSELS.

A fine spray applicator, as shown on the appended diagram has been designed for use in the Royal Australian Navy.

2. It is approved for ships concerned to raise demands on Naval Stores for the provision of these applicators as follows:—

Platypus, Stuart, L.S.I.'s	9 per ship.
Frigates and Sloops	8 per ship.
A.M.S. Vessels—Bathurst, Lismore, Maryborough, Ballarat, Goulburn, Bendigo, Burnie, Whyalla, Kalgoorlie, Toowoomba, Rockhampton, Townsville, Mildura, Warrnambool, Bundaberg, Deloraine, Castlemaine, and Dubbo	3 per ship.

(475/203/2.)

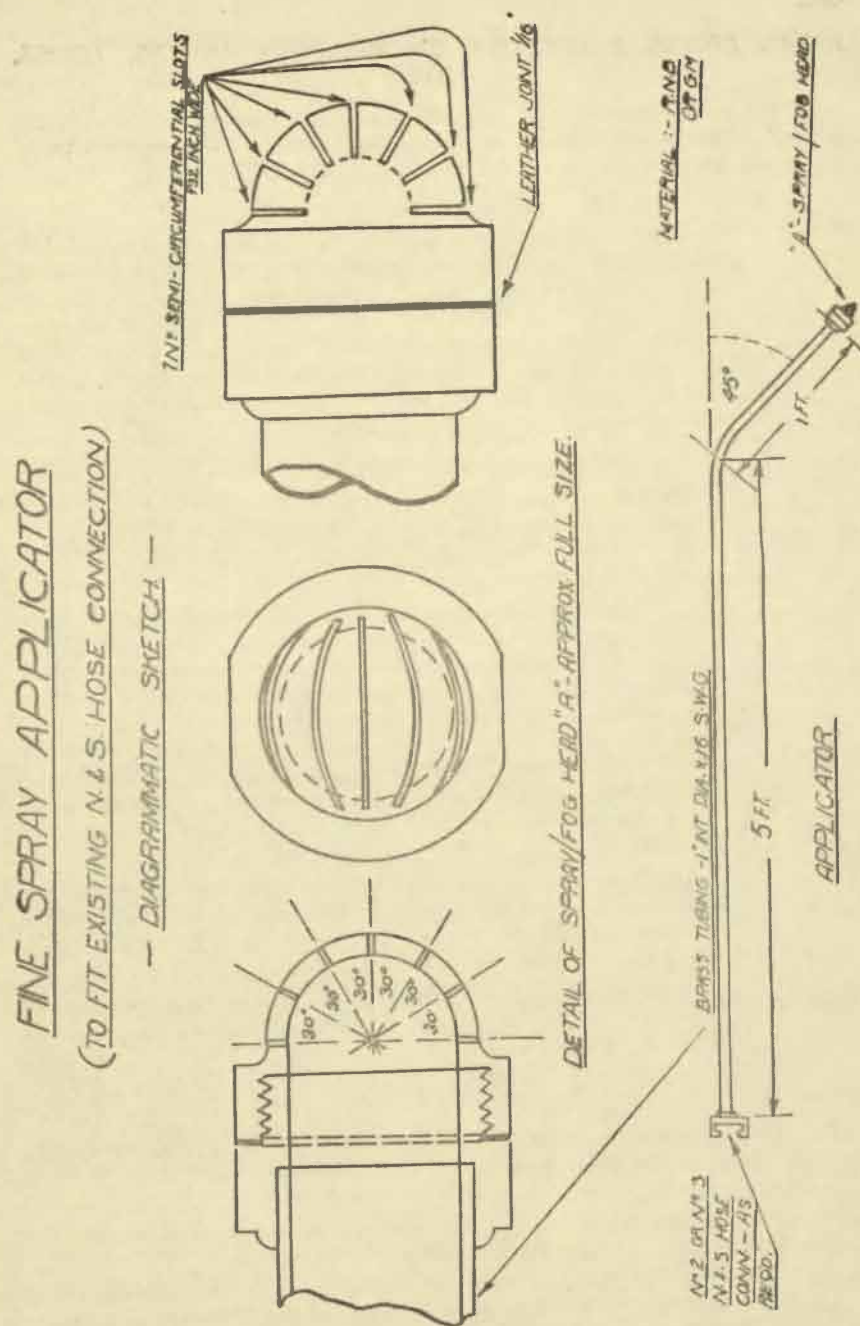

481.

NAVAL STORES—PREVENTION OF MISAPPROPRIATIONS, LOSSES, ETC.

The following instructions in regard to care and custody of Naval Stores in H.M.A. Ships and Establishments and action to be taken in the case of losses are brought to the notice of all concerned:—

A.—*Prevention of Misappropriation.*

(1) All officers are to use their best endeavours to check the misappropriation of stores especially when their ships are fitting out or paying off, when vessels are alongside, or in other circumstances likely to offer exceptional opportunities for misappropriation. Commanding officers are to ensure that the provisions of this Order are brought to the notice of responsible officers and others concerned on all occasions immediately before the vessel is placed in dockyard hands.

B.—*Care of stores in ships under repair, etc.*

(2) Attention is particularly drawn to the need for all possible precautions to be taken to avoid losses of stores by theft when ships are under repair, while in commission with stores on board at refitting yards, etc.

(3) Portable valuable stores that are particularly liable to misappropriation, e.g., binoculars, watches, telescopes, W/T equipment, electrical instruments, etc., are to be kept in a place of security. A locked drawer or cupboard in an officer's cabin is *not* considered to provide sufficiently secure stowage against theft whilst the vessel is in dockyard or contractors' hands for refit, nor, in connection with navigational watches, is the locked compartment provided in the chart room (in certain classes of ships) for stowing chronometers and watches regarded as adequate.

(4) If workmen are likely to be employed in compartments where such valuable stores are normally stowed, alternative arrangements should be made for the stores to be removed to a safe place on board or ashore.

(5) Commanding Officers are to ensure that satisfactory arrangements are made to safeguard all stores and particular attention should be given to—

(a) Arrangements for custody and issue of keys of store-rooms.

(b) Posting of sentries in accordance with K.R. and A.I., Article 738, and in storerooms, when work is being carried out in those compartments.

(c) Arrangements for special police supervision at the dockside when practicable.

(6) In cases of theft or suspected theft, the time factor is important. A preliminary notification should therefore be made to the police (dockyard or local) as early as possible.

(7) It is desirable, whenever possible, that stores should be landed during refit. Base Supply Staffs cannot undertake to

assist in destoring but the Naval Store Officer or local Base Supply Officer, should endeavour to make a lay-apart store available in which the ship can deposit the stores, at the ship's risk, and hold the key. This does not apply to valuable portable items referred to in paragraph 3. When such stores are landed for safe custody they should be taken personally to the appropriate Naval Store Depot or Base Naval Store and a receipt obtained for them on the spot. In the case of ships undergoing refit at Garden Island, valuable stores should be deposited with the Superintending Naval Store Officer in accordance with Clause 2, Article 115, Sydney Port Orders, for safe custody during period of refit.

C.—*Valuable and important Naval Stores—General Precautions.*

(8) Particular care is to be taken at all times to safeguard important and valuable stores. Such items which are portable are invariably to be locked up when not actually in use, and care should be taken to ensure that the persons responsible for any such stores, and any other persons authorized to use them, are fully acquainted with the regulations regarding their safe custody.

D.—*Bicycles.*

(9) All Departmental bicycles are to be branded with the letters "R.A.N." and provided with a suitable locking device. Arrangements should be made to ensure that, when bicycles are left unattended, they are securely locked to prevent unauthorized removal.

E.—*Procedure for dealing with losses.*

(10) The procedure for dealing with losses is set out in K.R. and A.I., Articles 1936 and 1938 and in B.R. 4, Chapter XII., and R.A.N. Supplement to B.R. 4.

(11) Losses of valuable and important Naval Stores whether by accident or neglect are invariably to be reported in detail to the Naval Board. For this purpose, important and valuable Naval Stores include:—

(i) Ships' anchors, Boats, Binoculars, Telescopes, Stop Watches, Electrical Instruments, Portable W/T Radar A/S, etc., equipment.

(ii) Any single item of value of £5 or more.

(iii) Groups of items of value of £5 or more lost at the same time or in the same set of circumstances.

(12) When forwarding particulars of a loss to the Naval Board, the Naval Officer-in-Charge or Commanding Officer concerned is to ensure that all relevant facts are reported and it should always be stated whether it is considered the loss was due to accident or neglect. In the latter case it should be stated whether recovery of the value or part value of the missing item has been effected as provided in Naval Financial Regulations and Instructions, Article 9.

2. Navy Orders 406, 426, and 611 of 1943 are cancelled.

(612/201/5941.)

482.

SERVICE SYSTEM CANTEENS—RENDITION OF REPORTS ON PAYING OFF.

The following general signal, T.O.O. 101151 October, is included in Navy Order for the guidance of all concerned:—

“Special attention is drawn to Item 10 of Commonwealth Navy Order 618 of 1944 which requires rendition to Director of Victualling of reports of Service System Canteens on paying off.

2. Commanding Officers of all Ships and Establishments in which such canteens are operating, are to ensure that final canteen accounts are carefully compiled in sufficient time to permit of complete audit by representatives of the Canteen Committee for presentation to the Committee, before paying off.

3. In particular, all outstanding accounts, including any liability for advances from public funds, are to be settled before paying off and stock and other assets realized or disposed of in accordance with the decisions of the Committee and the Commanding Officer's approval.

4. The report forwarded to the Director of Victualling is to be accompanied by a final balance-sheet and a statement certified by the Commanding Officer showing the disposal of assets, including stock and cash.

5. When determining the disposal of cash assets, the Canteen Committee of each Ship or Establishment is requested to give consideration to making a donation to the R.A.N. Relief Fund, the purposes of which are outlined in Navy Order 264 of 1941.

6. Items of canteen equipment originally received as gifts or presentations from charitable or patriotic organizations are not to be regarded as the property of the canteen but are to be accounted for and disposed of strictly in accordance with C.O.R., Article 396.

7. The attention of Commanding Officers and Canteen Committees is drawn to A.F.O. 4835/45 and the procedure outlined therein is to be observed as a general guide to ensure the efficient audit of canteen accounts.

8. It is emphasized that it is the direct responsibility of each Commanding Officer to exercise the closest supervision in order to ensure strict compliance with the foregoing when for any reason a Service System Canteen is terminated.”.

(427/201/909.)

483.

PROCEDURE FOR DEALING WITH VICTUALLING STORES IN TENDERS PAYING OFF AS A RESULT OF GENERAL DEMOBILIZATION.

The following instructions regarding victualling stores and accounts of H.M.A. Ships paying off on demobilization, are promulgated for general guidance and are to be observed by all concerned:—

A.—General.

(a) At Sydney, the provisions of Article 133 of Sydney Port Orders are to be observed in conjunction with any additional instructions contained in this Order.

- (b) Ships paying off at Fremantle, Brisbane, and Melbourne, are to return all victualling stores (excepting fresh provisions) to the local Victualling Depot.
- (c) If suitable storage space is available in the local Naval Base, fresh provisions remaining on board are to be transferred to the Base Supply Officer for early consumption, otherwise the Base Supply Officer concerned will arrange disposal to best advantage.
- (d) At Adelaide, Hobart, or other ports where no Victualling Depot is maintained, all victualling stores are to be returned to the local Naval Establishment which will take on charge and issue receipts for all quantities returned.
- (e) When advice is received by a Commanding Officer that the ship under his command is to pay off, arrangements are to be made to complete, in advance, as much work as possible in connection with a full muster of all types of victualling stores on charge and to initiate preliminary arrangements for their disposal, all stores on loan issue being collected and accounted for as early as practicable after arrival in port. Arrangements are to be made for all stores ratings borne to be retained until all stores are returned and accounts finally closed.
- (f) As soon as possible after arrival at the paying-off port, the Commanding Officer is to advise the Base Supply Officer of the approximate quantity of stores to be returned, indicating when such stores will be available for removal. The Base Supply Officer will then arrange with the local Victualling Store Officer accordingly, any additional working parties necessary for the handling and forwarding of stores being provided as required.
- (g) Base Supply Officers are to arrange suitable facilities for transporting victualling stores from ship to their destination and for their safe custody during transit.
- (h) Articles of Clothing, Officers' Mess Traps, Implements and Mess Utensils are to be securely packed for return with packing list enclosed in each package. Cases required for this purpose, also necessary packing material for fragile articles, may be obtained from the local Victualling Yard or Depot. The packing lists are to be prepared in duplicate, both copies being signed by the Officer of the ship detailed for victualling duties. The duplicate copy of the packing list is to be forwarded as an attachment to the Return Note referred to in paragraph (i).
- (i) In all instances, Return Notes are to be sent before or with the stores, and a responsible stores or other senior rating is to accompany the stores to the establishment concerned in order that losses or damage in transit may be avoided.
- (j) To facilitate the prompt closing of the ship's accounts, it is important that returns be checked without delay and receipts forwarded by receiving officers to the ship.

B.—Closing of Accounts.

All provisions, clothing, implement and officers' mess trap accounts are to be completed in accordance with the printed instructions, special care being taken to ensure that all transactions relevant to the accounts are supported by duly completed vouchers. Repayment mess balances and debit balances in respect of mess traps replacement allowances are to be calculated without delay and transmitted to the parent ship.

C.—Discrepancies of Stores and Losses by Neglect.

Any discrepancies in victualling stores discovered on paying off are to be investigated forthwith by the Commanding Officer and dealt with as specified in Navy Order 454 of 1945.

In the event of large discrepancies being disclosed, a detailed explanatory report is to be furnished to the Naval Officer-in-Charge of the port concerned. Such reports are to include a list of the discrepancies disclosed, indicating whether losses are considered to be attributable to the neglect of any officer or rating together with recommendations and proposals for recovering the value of losses. In this regard the attention of Commanding Officers is drawn to K.R. and A.I. 1853A and the instructions contained in the Victualling Store Accounts—A.S. 462 series. Where necessary a Board of Inquiry will be arranged for by the Naval Officer-in-Charge to ascertain responsibility.

D.—Mess Debts.

(a) Commanding Officers are responsible that any mess debits incurred by repayment messes are recovered from messes concerned before paying off, for payment to the Base Supply Officer—see Section B, above.

(b) Any debit balance resulting from the replacement of consumable items of Officers' Mess Traps and Seamen's mess utensils in excess of the authorized free replacement is also to be recovered from the messes concerned and paid to the Base Supply Officer.

E.—Mustering and Packing.

Dry Provisions, Loan and Repayment Clothing, Mess Traps and Implement Account stores, are to be carefully mustered and checked and dealt with in accordance with Section A above, Return Notes in duplicate being prepared on Forms A.S. 549 for the actual quantity of stores concerned, copy of which is to accompany such stores to the Victualling Yard. Care is to be taken that articles of mess and galley gear, etc., are properly cleaned before return.

F.—Supervising Stores Officers.

(a) Arrangements have been made for a Warrant Stores Officer attached to the staff of Director of Victualling to be in attendance at each port to supervise and advise on all matters relating to the return of stores and the closing of accounts. These officers will prepare a report in

triplicate indicating the condition of store accounts and stores of each ship dealt with, one copy being forwarded to the Director of Victualling, one to the Naval Officer-in-Charge and one to the Commanding Officer of the ship concerned.

(b) When the ship's and parent ship's copies of the final accounts have been duly completed, the Warrant Stores Officer referred to in (a) Section F, is to initial each account concerned and arrange for them to be forwarded to the relevant Parent Ship by hand or by registered post as necessary.

(603/246/5381.)

484.**KIT BAGS, HAMMOCKS, ETC.—LOSSES DURING TRANSPORT—
LABELLING AND MARKING.**

With reference to paragraph 21 of Navy Order 264 of 1945, C.O.R., Article 407 and Naval Financial Regulations and Instructions, Article 243, clause 3, are not to be cancelled. The operation of the latter is suspended so far as baggage forwarded through Military Forwarding Officers by troop train is concerned.

(516/201/686.)

485.**HONORARY MEMBERSHIP OF GOLF CLUBS—VICTORIA.**

With reference to Navy Order 182 of 1941, the Royal Melbourne Golf Club have now decided that it will be necessary for any Service visitor who wishes to play at the club to be introduced by a member and that payment of the usual visitor's fee will be required.

(462/201/2371.)

RESTRICTED.(FOR OFFICIAL USE ONLY.)**Commonwealth Navy Orders.**

Navy Office, Melbourne,
30th October, 1945.

The following Orders, having been approved, are hereby promulgated for information and guidance, and necessary action.

By direction of the Naval Board,

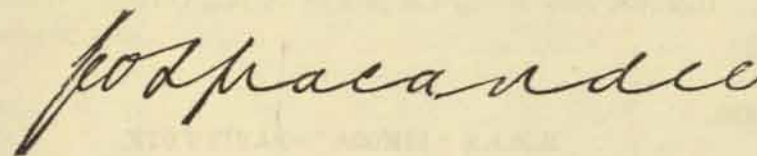

Secretary.

*The Commodore Commanding H.M.A. Squadron,
and Commanding Officers of H.M.A. Ships,
Officers in Charge of H.M.A. Naval
Establishments, and others concerned.*

TABLE OF CONTENTS.

No.	Subject.
486.	H.M.A.S. "Gilolo"—Commissioning.
487.	H.M.A.S. "Misima"—Paying off.
488.	H.M.A.S. "John Hardy"—Paying off.
489.	H.M.A.S. "Limosa"—Paying off.
490.	H.M.A. M.L. 426—Paying off.
491.	H.M.A. M.L. 802—Paying off.
492.	H.M.A. M.L. 803—Paying off.
493.	H.M.A. M.L. 807—Paying off.
494.	H.M.A. M.L. 823—Paying off.
495.	H.M.A. H.D.M.L. 1129—Paying off.
496.	H.M.A. H.D.M.L. 1346—Paying off.
497.	Non-Substantive Rate of Qualified Ordnance (Optical)—Short Title Q.O. (O).
498.	Quarantine Control—Animals and Articles Subject to.
499.	Supply of W.R.A.N.S. Officers' and R.A.N. Nurses' Uniforms.

486.

H.M.A.S. "GILOLO"—COMMISSIONING.

H.M.A.S. *Gilolo* (Royal Australian Naval Base, Morotai) was commissioned on 15th October, 1945.

2. In conformity with Navy Order 177 of 1943, the motor launch A.W.B. 402 has been commissioned as H.M.A.S. *Gilolo*.

(603/246/5292.)

487.

H.M.A.S. "MISIMA"—PAYING OFF.

H.M.A.S. *Misima* was paid off on 12th October, 1945.

(603/246/5446.)

488.

H.M.A.S. "JOHN HARDY"—PAYING OFF.

H.M.A.S. *John Hardy* was paid off on 16th October, 1945.

(674/204/3202.)

489.

H.M.A.S. "LIMOSA"—PAYING OFF.

H.M.A.S. *Limosa* was paid off on 24th October, 1945.

(603/246/4417.)

490.

H.M.A. M.L. 426—PAYING OFF.

H.M.A. M.L. 426 was paid off on 15th October, 1945.

(603/294/1521.)

491.

H.M.A. M.L. 802—PAYING OFF.

H.M.A. M.L. 802 was paid off on 15th October, 1945.

(603/294/1521.)

492.

H.M.A. M.L. 803—PAYING OFF.

H.M.A. M.L. 803 was paid off into reserve on 17th October, 1945.

(603/246/5445.)

493.

H.M.A. M.L. 807—PAYING OFF.

H.M.A. M.L. 807 was paid off on 23rd October, 1945.

(603/294/1522.)

494.

H.M.A. M.L. 823—PAYING OFF.

H.M.A. M.L. 823 was paid off on 23rd October, 1945.

(603/294/1522.)

495.

H.M.A. H.D.M.L. 1129—PAYING OFF.

H.M.A. H.D.M.L. 1129 was paid off into F class reserve on 5th October, 1945.

(603/297/641.)

496.

H.M.A. H.D.M.L. 1346—PAYING OFF.

H.M.A. H.D.M.L. 1346 was paid off into reserve on 17th October, 1945.

(603/246/5445.)

497.

NON-SUBSTANTIVE RATE OF QUALIFIED ORDNANCE (OPTICAL)—SHORT TITLE—Q.O. (O).

It has been decided to introduce a new non-substantive rate for seaman ratings who qualify in optical work.

2. The title will be Qualified Ordnance (Optical)—short title Q.O. (O).

3. The non-substantive rate will be open to Able Seaman without higher non-substantive rates and will carry payment of 3d. per diem.

4. The duties of these ratings will be to assist Ordnance Artificer (O) in general and to attend to the "blooming plants".

5. Ratings selected will undergo a four weeks' initial course of training in H.M.A.S. *Lonsdale* before being drafted to assist Ordnance Artificer (O).

6. Names of selected able seamen who show an aptitude for such work are to be forwarded to the Naval Officer-in-Charge, Flinders Naval Depot.

7. Subject to the recommendation of the Gunnery Officer, the paid acting non-substantive rate of Q.O. (O) may be granted in each of the following H.M.A. Ships and Establishments to one rating who has been continuously employed assisting the Ordnance Artificer (O) for a period of three months:—

H.M.A.S. *Lonsdale*.H.M.A.S. *Leeuwin*.H.M.A.S. *Torrens*.H.M.A.S. *Platypus*.H.M.A.S. *Melville*.H.M.A.S. *Magnetic*.

8. The earliest date from which the paid acting non-substantive rate may be granted is 1st July, 1945.

(348/216/1.)

(This Order will be reprinted for posting on Notice Boards.)

498.

QUARANTINE CONTROL—ANIMALS AND ARTICLES SUBJECT TO.

The entry into Australia of animals or birds from places outside Australia is subject to strict regulation under the Quarantine Act, owing to the risk of the introduction of rabies, piroplasmosis and other diseases.

2. Under no circumstances will permission be granted for the conveyance by sea from places outside Australia to the Commonwealth of Australia proper, including islands adjacent to the coast, of—

- (a) living mascots, pets or other animals or birds, whether acquired before or after embarkation from Australia;
- (b) plants, fruit, seeds and any parts of plants including straw and grass;
- (c) reptiles or living insects;
- (d) parts of animals such as skins, horns, hooves, wool, hair and feathers, unless such articles have been processed or manufactured.

3. Commanding Officers of Ships and Establishments are to take action with local civil quarantine authorities to have destroyed forthwith, living mascots, pets, animals or birds from outside the Commonwealth of Australia, which disembark at a port in Australia.

4. Birds or animals in a Ship proceeding from one overseas port to another, may enter an Australian port *en route*, providing that such animals or birds are kept securely on the vessel and are not permitted to land. On arrival of the vessel, the Commanding Officer is to advise the local civil quarantine officer and make necessary arrangements with him for inspection and security of the animals or birds.

(653/201/61.)

499.

SUPPLY OF W.R.A.N.S. OFFICERS' AND R.A.N. NURSES' UNIFORMS.

Uniforms for W.R.A.N.S. officers and R.A.N. nurses are not now available from R. Simons and Sons, 313 Flinders-lane, Melbourne, the firm having withdrawn from the Agreement to supply.

2. Navy Order 213 of 1945 is to be amended accordingly.

(434/215/1129.)

RESTRICTED.(FOR OFFICIAL USE ONLY.)**Commonwealth Navy Order.**

Navy Office, Melbourne,

6th November, 1945.

The following Order, having been approved, is hereby promulgated for information and guidance and necessary action.

By direction of the Naval Board,

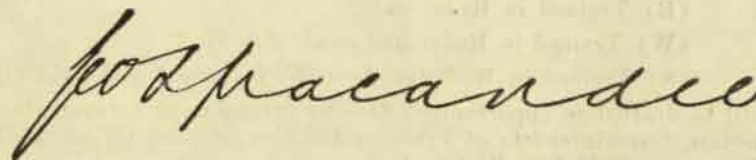

Secretary.

*The Commodore Commanding H.M.A. Squadron,
and Commanding Officers of H.M.A. Ships,
Officers in Charge of H.M.A. Naval
Establishments, and others concerned.*

TABLE OF CONTENTS.

No.

Subject.

500. Radio Mechanic Branch—Training and Advancement.

C.10651/45.

500.

RADIO MECHANIC BRANCH—TRAINING AND ADVANCEMENT.

The introduction of the rating of Radio Mechanic (C) promulgated in Naval Board's General Message Navy Circ. 8771, timed 1241 of 9th May, 1945, necessitates a revision of the rules for training and advancement of Radio Mechanics.

Radio Mechanics (C) will be trained in all forms of Radar and W/T (meaning W/T, R/T, D/F, &c.), Electronic Navigational Aids (including Loran, &c.), and Radio Counter Measures (meaning all radio counter measures including Radar).

2. The necessary steps to establish the rating of Radio Mechanic (C) are set out in this Order under the following headings:—

Part I.—Transfer of existing categories of Radio Mechanics to Radio Mechanics (C).

Part II.—Transfer of ratings from W/T Branch to Radio Mechanics (C).

Part III.—Transfer of ratings from other Branches to Radio Mechanics (C).

Part IV.—Training and advancement of Radio Mechanics (C).

Part I—Transfer of Existing Categories of Radio Mechanics to Radio Mechanic (C).

3. Existing categories of Radio Mechanics, i.e.—

(R) Trained in Radar only,

(W) Trained in Radar and small ship W/T,

(S) Trained in W/T for shore W/T stations and light craft,

will be drafted as opportunity offers by arrangement between the Commodore, Superintendent of Training and Commanding Officer, H.M.A.S. *Watson*, to H.M.A.S. *Watson* for conversion courses as follows:—

(R) 6 weeks' course in W/T, Electronic Navigational Aids and R.C.M.

(W) 6 weeks' course in W/T, Electronic Navigational Aids and R.C.M.

(S) 15 weeks' course in Radar, Electronic Navigational Aids and R.C.M.

4. On successful completion of these courses, ratings will be transferred to Radio Mechanic (C) with their original substantive rating and seniority.

5. *Failure to Qualify.*—Ratings remain in their original category and may not be recommended for a further course until twelve months after date of failure.

6. (a) Radio Mechanics (W) who fail or who have no opportunity to carry out course in paragraph 3 may be advanced to Petty Officer Radio Mechanic (W) by Commanding Officers on attaining one year's seniority as Leading Mechanic (W) in accordance with paragraph 19 (a).

(b) Leading Radio Mechanics (S) who fail or who have no opportunity to carry out course in paragraph 3 may be advanced to Petty Officer Radio Mechanic (S) in accordance with Navy Order 156 of 1945.

(c) Advancement to C.P.O. Radio Mechanic (C) is shown in paragraph 19 (b). For the present, owing to the difficulty of drafting Petty Officer Radio Mechanics for courses shown in paragraph 3 above, Petty Officer Radio Mechanics of any other category who are qualified in accordance with paragraph 19 (b), sub-paragraphs (i) and (iii) may be advanced to Acting C.P.O. Radio Mechanic in their existing category to fill Fleet Numbers without completing the required course. Ratings must, however, successfully complete the required course before being confirmed C.P.O. Radio Mechanic.

Part II—Transfer of Ratings from W/T Branches to Radio Mechanic (C).

7. Telegraphist ratings may volunteer for transfer to Radio Mechanic (C) provided they hold a W/T 3 higher standard non-substantive rate, or above. Names of recommended volunteers should be forwarded to the Commodore Superintendent of Training, copy to Commanding Officer, H.M.A.S. *Watson*. As only very limited numbers can be accepted, selection will be made from volunteers by arrangement between the Commodore Superintendent of Training and the Commanding Officer, H.M.A.S. *Watson*. Ratings selected will be drafted to H.M.A.S. *Watson* for a conversion course.

8. On successful completion of a course of fifteen weeks in Radar, Electronic Navigational Aids and R.C.M., ratings will be transferred to their equivalent substantive rating with their original seniority in that rating except that W/T 3 (higher) will be transferred to Radio Mechanic on the date of qualifying in this course and advanced to Leading Radio Mechanic the following day.

9. *Failure to Qualify.*—Ratings who fail retain their present rating and may not apply for a further course until twelve months after the date of failure.

Part III—Transfer of Ratings from Other Branches to Radio Mechanic (C).

10. Ratings below leading rate of all branches (whether C.S., Reservists or H.O.) may volunteer for transfer to Radio Mechanic (C).

11. Ratings volunteering must be between 18 and 30 years and hold an Intermediate Certificate but Leaving Mathematics and Physics or Technical School equivalent is desirable. Names of recommended volunteers are to be forwarded to the Commodore Superintendent of Training (copy to the Commanding Officer, H.M.A.S. *Watson*) with the following information:—

(i) Age.

(ii) Educational qualifications, stating subjects.

(iii) Any other special courses.

(iv) Previous radio experience.

(v) General opinion of rating.

12. From the roster established from these applications, pre-selection will be made by the Commanding Officer, H.M.A.S. *Watson* who will apply to the Commodore Superintendent of Training for appropriation of pre-selected ratings to H.M.A.S. *Watson* for final selection.

13. Ratings finally selected will carry out the following courses at H.M.A.S. *Watson*—

24 weeks Mathematics, Electrical Science and Technology and Radio.

6 weeks W/T.

2 weeks Electronic Navigational Aids.

1 week R.C.M.

15 weeks Radar.

14. During the course, ratings will retain existing rating until successful completion of the 24 weeks' theory and six weeks' W/T course when they are to be transferred to Radio Mechanic (C) from the date of qualifying and advanced to Leading Radio Mechanic (C) the following day. Thereafter advancement is to be as in paragraph 19.

15. Ratings failing to qualify are to be returned to their previous Branch.

Part IV—Training and Advancement of Radio Mechanics (C).

16. (a) *Direct Entries*—Ordinary Seamen (Radio Mechanics).—Ordinary Seamen (Radio Mechanics) will be given a course as in paragraph 13 for Radio Mechanic (C) at H.M.A.S. *Watson* after completing disciplinary training at Flinders Naval Depot.

(b) *Selection*.—On application for entry as O/Sea. (Radio Mechanic), Recruiting Officers are to forward information as laid down in paragraph 11 to the Commodore Superintendent of Training and the Commanding Officer, H.M.A.S. *Watson*.

Preliminary selection will be made in the same way as for ratings transferred from other Branches and the ratings chosen will be interviewed by an officer delegated by H.M.A.S. *Watson* for further selection as under:—

(i) Those from Queensland and N.S.W. at H.M.A.S. *Watson*.

(ii) Those from Victoria and Tasmania at H.M.A.S. *Lonsdale*.

(iii) Those from Sth. Australia at H.M.A.S. *Torrens*.

(iv) Those from West Australia at H.M.A.S. *Leeuwin*.

Selected ratings are to be placed on a roster and entries will be made as required.

17. Ordinary Seaman (Radio Mechanic) will be transferred to Radio Mechanic (C) on successful completion of 24 weeks' theory and six weeks' W/T from the date of qualifying and advanced to Leading Radio Mechanic (C) the following day.

18. Ordinary Seamen (Radio Mechanics) who fail to qualify may be required to transfer to other Branches.

19. *Advancement*.—(a) After one year's service as Leading Radio Mechanic (C) or a combined total of one year's service as Leading Radio Mechanic (W) or (S) and Leading Radio Mechanic (C) advancement to Acting Petty Officer Radio Mechanic (C) may be made by the Commanding Officer if satisfied that the man is technically suitable for the rate and his conduct is satisfactory. If after eighteen months as Leading Radio Mechanic he is still not considered suitable for rating to Acting Petty Officer, the facts are to be reported to the Naval Board (copy to the Commodore Superintendent of Training and the Commanding Officer, H.M.A.S. *Watson*) in order that his retention in the Branch may be considered. A full statement of the circumstances is to be made, giving reasons which may exist for his incompetence or any details as to misconduct. An Acting Petty Officer may be confirmed Petty Officer Radio Mechanic on completing twelve months' service as such, provided he holds a certificate signed by a qualified Communications or Radar Officer stating that he is technically competent or that the rating has successfully completed a six weeks' re-qualifying course and that his conduct has been satisfactory. This certificate, of course, may be obtained at any time after being rated Acting Petty Officer Radio Mechanic (C).

(b) Qualification for C.P.O. Radio Mechanic (C)—P.O. Radio Mechanics (C) must have—

(i) Completed three years as such, or a combined total of three years' service as a P.O. Radio Mechanic (R), (W), or (S) and P.O. Radio Mechanic (C).

(ii) Successfully completed a six weeks' re-qualifying course at H.M.A.S. *Watson*. Courses shown in paragraphs 3 and 8 will count in lieu of this, if ratings have been transferred from existing Radio Mechanics (R), (W), or (S) or telegraphist branch.

(iii) Been recommended on form S.507 by Commanding Officer.

NOTE.—Commanding Officers may at any time recommend for special advancement ratings who have gained outside the Naval Service the qualifications required for higher rating. All such cases are to be referred to the Naval Board through the appropriate administrative authority. FULL details in justification of the recommendation for such advancement must be given.

20. It is anticipated that further alteration will be required in the training and advancement in the Radio Mechanic Branch in the light of post-war policy and requirements. When these are known, applications will be called for permanent service engagements from Radio Mechanics (C) and the telegraphist branch.

21. *Uniform*.—C.P.O. Radio Mechanics will wear Class I uniform; others will wear Class III uniform. The badges to be worn by all types of Radio Mechanics are detailed in A.F.O. 1261/44.

22. *Messing*.—Radio Mechanics will use the Artisans' Mess.

23. *Medical Standard*.—In general, ratings should be Grade I, medical and vision standard IV or better. Lower vision standards may be accepted with the approval of the Naval Board.

24. *Disrating and Re-advancement.*—The rules for disrating and re-advancement in the Radio Mechanic Branch are those which are applicable to ratings other than those advanced by classes. The lowest rating to which a man may be disrated is Radio Mechanic.

25. Navy Orders 501 of 1944 and 156 of 1945 refer.

26. Navy Orders 414 of 1943 and 360 of 1944 and Confidential Commonwealth Navy Order 25 of 1945 are hereby cancelled.

(614/217/10.)

RESTRICTED.(FOR OFFICIAL USE ONLY.)

Commonwealth Navy Orders.

Navy Office, Melbourne,
6th November, 1945.

The following Orders, having been approved, are hereby promulgated for information and guidance, and necessary action.

By direction of the Naval Board,

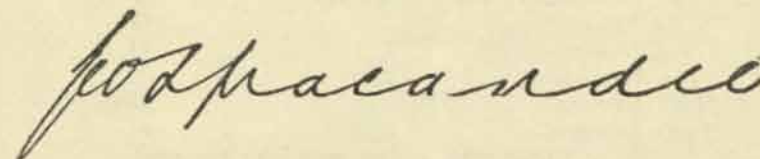

Secretary.

*The Commodore Commanding H.M.A. Squadron,
and Commanding Officers of H.M.A. Ships,
Officers in Charge of H.M.A. Naval
Establishments, and others concerned.*

TABLE OF CONTENTS.

No.	Subject.
501.	H.M.A. G.P.V. 961—Commissioning.
502.	H.M.A.S. "Diamond Snake"—Paying Off.
503.	Signals—Indications of Priority.
504.	Leave Entitlements.
505.	Ammunition—2 pdr.—Unhooking of Links.
506.	Lubricating Oils—Accounting for.
507.	Gas Cylinders.
508.	Books and Forms.
509.	Destoring of Ships on General Paying Off—Medical and Dental Stores.

C.10652/45.

501.

H.M.A. G.P.V. 961—COMMISSIONING.

H.M.A. G.P.V. 961 was commissioned on 19th October, 1945.
(603/246/5477.)

502.

H.M.A.S. "DIAMOND SNAKE"—PAYING OFF.

H.M.A.S. *Diamond Snake* was paid off on 19th October, 1945.
(603/246/5479.)

503.

SIGNALS—INDICATIONS OF PRIORITY.

On the reversion to British Signal Books and Publications as from 1st November, 1945, British Indications of Priority will replace United States Indications of Precedence listed in Navy Order 337 of 1945.

2. British Indications of Priority are—

(i) Most Immediate	O-U
(ii) Emergency—Enemy Aircraft	O-A
(iii) Emergency	O
(iv) Immediate	O-P
(v) Important	P
*(vi) Routine	R
(vii) Deferred	D

* Only used in dual precedence messages.

3. Full instructions are contained in General Signalling Instructions.

4. When Combined Communication Procedure is used, C.C.B.P's 1 and 5 are applicable.

5. Navy Order 337 of 1945 is cancelled.

(2037/2/1352.)

504.

LEAVE ENTITLEMENTS.

It has been decided to bring the Navy into line with the other Defence Services as regards leave entitlements and the following instructions are substituted for those contained in Navy Order 38 of 1941, and C.O.R., Articles 267, 268, 269 and 277, unless otherwise indicated. The provisions of this Order will not apply to personnel of the R.N. or any of the Dominions serving in the R.A.N. on loan or on exchange duty.

War Service Leave.

2. War service leave will accrue in respect of—

- (a) Service at sea or on shore since the commencement of the War, viz., 3rd September, 1939, outside the South-West Pacific Zone, which would normally have carried an entitlement to foreign service leave.

- (b) Service at sea since the commencement of the War, viz., 3rd September, 1939, inside the South-West Pacific Zone, as may have been classified as service outside Australia for the purposes of exemption from taxation under the Income Tax Assessment Acts, provided that, in arriving at war service leave credits for the period 3rd September, 1939, to 6th December, 1941, inclusive, account is taken of any periods of home service leave granted during this period in excess of 24 days per annum.

- (c) Service on shore subsequent to 7th December, 1941, inside the South-West Pacific Zone but outside the mainland of Australia, as may be classified as service outside Australia for the purpose of exemption from taxation under the Income Tax Assessment Acts.

3. War service leave will accrue at the rate of seven and a half days for each completed six months, a broken period in total of over four months' service will count as six months and a half-day in total will count as a full day.

4. Where war service leave accrued does not amount to fourteen days, a minimum of fourteen days will be deemed to have accrued.

5. In the case of "hostilities only" personnel and members of the Permanent Naval Forces discharged during hostilities and the demobilization period, payment will be made in a lump sum in lieu of war service leave. This payment will be made by Navy Office after final discharge. Instructions will be issued in due course in regard to serving members of the Permanent Naval Forces.

6. There is to be no minimum period of service in the South-West Pacific Zone (outside the mainland of Australia) to qualify for war service leave, provided a member is appointed to a seagoing ship, or an establishment outside the mainland of Australia which would be classified as service outside Australia for the purpose of the full exemptions from taxation under the Income Tax Assessment Acts. Where a member has temporary duty in the South-West Pacific Zone but outside the mainland of Australia which would not necessitate an appointment away from his base, there is to be a qualifying period of 90 days' continuous service or 180 days in the aggregate.

7. War service leave takes the place of foreign service leave.

Home Service Leave (not applicable to Naval Dockyard Police).

8. As from 1st July, 1942, home service leave will normally be limited to 24 days a year, calculated on the basis of two days for each completed month of service, in lieu of the existing maximum of 42 days per year.

Personnel are eligible for home service leave in respect of service—

- (a) at sea or on shore inside the South-West Pacific Zone,
(b) at sea or on shore outside the South-West Pacific Zone but inside the Pacific area and against the Japanese.

9. The special scale of leave for personnel serving on shore in Darwin, Thursday Island and the New Guinea Area is abolished.

10. Home service leave up to 24 days may be granted at any time during the leave year (i.e., from 1st February) in anticipation of the

period of accumulation being completed, and this amount of leave may be exceeded where, due to the exigencies of the Service, it is desired to give leave in excess of this amount.

11. The amount of leave due to personnel will be calculated at Navy Office by crediting two days' leave for each completed month of service from 1st July, 1942, and debiting leave taken since the same date. Any debit or credit balance will be carried forward from month to month.

This information will be extracted from the victualling columns of ships' ledgers; care should therefore be taken to distinguish on the ledger between disembarkation leave, compassionate leave, sick leave, home service leave and travelling periods.

Any leave taken during the current and the preceding quarter is to be noted on Form A.S.1031z on final discharge.

12. Payment in lieu will not be made in respect of home service leave to the estates of personnel who died prior to 1st April, 1945.

13. In the case of "hostilities only" personnel, and members of the Permanent Naval Forces discharged during hostilities and the demobilization period, payment in lieu for any balance of home service leave not taken will be made after final discharge. Instructions will be issued in due course in regard to serving members of the Permanent Naval Forces.

14. Where home service leave is in debit on final discharge, no financial adjustment will be made where the debit has arisen on compassionate grounds or because a member has been required to take his home service leave in anticipation of his entitlement and to suit Service requirements.

15. A debit balance of leave at the beginning of a leave year is not to restrict the amount of home service leave which may be given under paragraph 10.

Periods not to be Counted for War Service or Home Service Leave.

16. The following will not be counted as service qualifying for war service or home service leave:—

- (a) periods of absence on leave without pay,
- (b) periods awaiting trial, spent in cells, detention or in prison.

Classes of Members Disqualified for War Service Leave and/or Home Service Leave.

17. Payment in lieu of war service leave and/or accumulated home service leave will not be made where a member has been:—

- (a) discharged "RUN,"
- (b) dismissed from His Majesty's Service with disgrace,
- (c) dismissed from His Majesty's Service,
- (d) discharged from the Service as "Services No Longer Required,"
- (e) whose services are dispensed with on account of misconduct,
- (f) who is invalidated from the Service for causes due to misconduct or within his own control.

18. In the case of a recovered deserter becoming eligible by subsequent satisfactory service for the removal of "RUN," the Naval Board may, when approving of "RUN" being removed, also approve of any war service leave or accumulated home service leave being paid in lieu on final discharge.

Payment in Lieu of War Service Leave and for Home Service Leave Where a Member is Discharged Abroad.

19. Members discharged abroad will be paid in lieu of war service leave and any accumulated home service leave in Australian currency, as if their discharge had been effected in Australia.

Disembarkation Leave.

20. On return to Australia from service in an area where home service leave is not credited, disembarkation leave will be granted subject to the exigencies of the Service.

21. Ordinarily, disembarkation leave should be not less than fourteen days, but where little or no local leave has been taken during service in an area where such leave applies or in other special circumstances, the leave may be increased up to a maximum of 30 days.

22. Disembarkation leave taken on return to Australia will not be debited against any accrued home service leave.

23. Disembarkation leave will not be granted to personnel returned to Australia for disciplinary reasons.

Re-Establishment Leave.

24. Re-establishment leave will operate as from the 15th August, 1945. It will be granted to personnel discharged or demobilized on or after that date. Instructions regarding method and rate of payment have been promulgated. Personnel with six months' service or more will be entitled to 30 days' re-establishment leave and personnel with less than six months' service will be entitled to fifteen days' re-establishment leave.

25. A claim made by a member on the Repatriation Commission will be determined during the period of his re-establishment leave. The Repatriation Commission has arranged to provide medical treatment during the period of re-establishment leave in respect of all disabilities indicated by medical boards as apparently war related.

26. Navy Order 38 of 1941 is cancelled.

(556/201/1987.)

(This Order will be reprinted for posting on Notice Boards.)

505.

AMMUNITION—2 PDR.—UNHOOKING OF LINKS.

Prior to the receipt of A.F.O. 3625/45, a considerable quantity of Q.F. 2 pdr. ammunition was reconditioned in Australia and re-assembled using links ammunition and links connecting ammunition modified in accordance with A.F.O. 1944/44.

2. Boxes containing such ammunition are stencilled "Links examined under A.F.O. 1944/44."

3. Although these modified links ammunition do not bear the distinctive centre pop mark referred to in paragraph 3 of A.F.O. 3625/45, they are, however, fully serviceable.

(408/201/2093.)

506.

LUBRICATING OILS—ACCOUNTING FOR.

It has been brought to notice that difficulty in accounting for lubricating oils supplied in drums containing fractional quantities has been experienced at certain bases.

2. It has been decided, therefore, that such drums of oil may be accounted for by the consignee to the nearest full gallon (e.g., quantities between 44 and 44.5 gallons as 44 gallons, and from 44.5 to under 45.5 gallons as 45 gallons, &c.).

3. Any discrepancies arising as a result of the above method of accounting should be adjusted at the ship or base concerned by means of Report of Stocktaking, Form A.S.148.

(401/213/575.)

507.

GAS CYLINDERS.

The Marine Salvage Service advises that the following gas cylinders have been mislaid during salvage operations in northern waters:—

Oxygen—A.B.623, A.C.077, A.C.457, A.C.403, A.C.255, A.C.807, A.C.868, 1334, 1750, 5150, 6497, 7347, 7587, 9899, 20540, 20553, 29402, 50613, 50671, 50743, 50645, AA446, G3991, G20156, G22001, G24568 and X3571.

Hydrogen—H10123 and 5818.

Acetylene—2183, 50075, 55341, 70220, K1891, K2705, K2736, K2834, K3835, K4718, K5037, K5043 and K5053.

2. Some of these cylinders may have been left at naval establishments and a report should be furnished where any information is available as to their whereabouts or disposal.

(669/202/14.)

508.

BOOKS AND FORMS.

First supplies of the under-mentioned publications have been distributed:—

K.R.1-2/45.—Amendments to King's Regulations and Admiralty Instructions—1943 edition (B.R.31, 32 and 32A).

(A.F.O.'s 1779 and 3963/45.)
(584/203/139.)

B.R.118/1944.—The War Office Handbook, "Resuscitation, Equipment, Organization Training and Procedures."

(A.F.O. 2196/45.)
(571/202/2188.)

B.R.150.—Aircraft Recognition Manual—Amendment No. 11.

(A.F.O. 3411/45.)
(571/202/1646.)

B.R.268 (42)—Electrical Manual Volume II, Centralized Wire-less System Voltage Control Board for 400 Volts 50 Cycle, Single Phase Alternator.

(A.F.O. 3411/45.)
(571/202/2040.)

B.R.282/44.—D.E.M.S. Pocket Book.

(A.F.O. 84/45.)
(571/202/2137.)

B.R.323.—Establishment of Naval Stores for Gunnery Purposes and Form D.1281 List of Particulars—Errata No. 11.

(A.F.O. 6479/45.)
(571/202/1416.)

Geographical Handbook Series, Naval Intelligence Division:—

B.R.510.—"Indo China,"

B.R.518.—"Netherlands East Indies, Vol. I,

B.R. 519A.—"Pacific Islands, Vol. II,

B.R.530.—"China Proper," Vol. I.

(A.F.O. 1888/44.)
(571/202/2123.)

B.R.841.—Maintenance Routine for U.S.A. 22.4-in. Torpedoes, Mark XIII Mods. 1 and 2.

(A.F.O. 4370/43.)
(571/202/1843.)

B.R.1069.—Handbook for Echo Sounding Sets, Types 764 and 764A.

(A.F.O. 2804/45.)
(571/202/2031.)

B.R.1227.—"Your Ship." Notes and Advice to an Officer on assuming his first command.

(A.F.O. 1490/45.)
(571/202/2180.)

B.R.1238.—U.S. Publication, "Communication Instructions for Reporting Enemy Sightings" (Short title C.I.R.E.S.).

(1866/2/417.)

O.U.5365A.—Priced Vocabulary of Naval Armament Stores, Part I. Errata No. 18,

O.U.5365B.—Priced Vocabulary of Naval Armament Stores, Part II. Errata No. 33.

(A.F.O. 3411/45.)
(571/203/2559.)

A.P.2886B (late C.D.0846B).—Turning Equipment for Radar Aerials Turning Gear, Type 3.

(C.A.F.O. 1258/45.)
(571/201/4774.)

A.P.2887 Series (late C.D.0850 Series).

A.P.2887B.—I.F.F., Mark III and Ancillary Equipment—Equipments, Type A.B.R. and A.B.K.—1,

A.P.2887C.—I.F.F., Mark III and Ancillary Equipment—Equipment S.C.R.—695-A and S.C.R.—695-AZ (American Mk. IIIc).

A.P.2887D (2).—I.F.F. Mark III G.R. Receivers, Types R.3120 and R.3121.

(C.A.F.O. 1258/45.)
(571/201/4775.)

Aircraft Recognition Journal, Volume III, Nos. 8-10, April, May and June, 1945.

(A.F.O's 2804 and 3411/45.)
(415/201/1879.)

2. The under-mentioned Admiralty Form has been adopted for use in the R.A.N. First supply will be effected, without demand, by the Superintending Naval Store Officer, Sydney, when Form A.S.272 is to be considered obsolete.

S.272 (Revised—April, 1945).—Redress of Wrongs and Complaint of Unfair Treatment.

(480/202/4774.)

3. The under-mentioned forms have been adopted for use in the R.A.N. First supply will be effected, without demand, by the Superintending Naval Store Officer, Sydney.

0369.—Transport Receipt Record (Large and Small).
0370.—Daily Receipt Book.

(A.F.O. 1884/44.)
(480/201/3449.)

4. The under-mentioned forms have been adopted for use in the R.A.N. First supply will be effected, on demand, by the Superintending Naval Store Officer, Sydney.

0423.—History Sheet for Torpedoes 21-in. Mark IX**.
0424.—History Sheets for Torpedoes 21-in. Mark VIII***.

(480/201/3318.)

Dock Form A—Graving Docks.

(480/201/3535.)

509.

DESTORING OF SHIPS ON GENERAL PAYING OFF—MEDICAL AND DENTAL STORES.

The following instructions with respect to medical and dental stores in ships to be destored on paying off as a result of demobilization and reduction in the R.A.N. are promulgated for information, guidance and observance.

2. Commanding Officers of ships not carrying a medical officer, and medical and dental officers of ships are, where their ship is paying off, to arrange for stores on their charge to be returned to store via the channels outlined. The receiving officer for medical stores is the medical officer-in-charge of the depot. A clearance only will in all cases be given by the receiving officer of the destoring authority. "Auditing" and "passing in Office" of medical or dental store accounts will be effected by the Director of Naval Medical Services only, as heretofore.

3. (a) *Sydney and Port Stephens*.—All medical stores to be returned to the R.A.N. Medical Store, Glebe, accompanied by completed return note, A.M.165z, in quadruplicate (original, triplicate, quadruplicate and quintuplicate), the green duplicate copy being retained by the destoring vessel as a temporary receipt for attachment to the rough medical store account.

The fair medical store account is to be closed beforehand and forwarded to the Director of Naval Medical Services, Navy Office, immediately after return of the stores.

The medical and dental store officer is to receipt the green original copy and forward it immediately to the Director of Naval Medical Services in order to clear the audit of each account.

(b) *Newcastle*.—As only small vessels will be paid off in this port, small medical sets only will be involved.

Scale F or F.1.—Return medical stores to the Medical Officer, H.M.A.S. *Maitland*, under cover of A.M.165z. Receipted green original copy to be returned to the Commanding Officer as his receipt and the certified orange triplicate copy forwarded to the Director of Naval Medical Services, Navy Office.

Scale "E".—Return medical stores to the Medical Officer, H.M.A.S. *Maitland*, under cover of A.M.165z. Receipted green original copy is to be attached by the Commanding Officer to the medical store account which is to be closed beforehand. The account is then to be forwarded immediately to Navy Office.

(c) *Brisbane*.—Small craft only—as for Newcastle.

(d) *Townsville*.—Small craft only—as for Newcastle.

(e) *Darwin*.—H.M.A.S. *Platypus* to act as receiving officer for medical store temporarily until plans are finalized.

Routine as for Sydney—Senior Medical Officer, H.M.A.S. *Platypus*, acting as receiving officer for medical stores pro. tem.; or in the event of *Platypus* not being attached, H.M.A.S. *Melville* to act.

(f) *Fremantle*.—As for Sydney. Petty officer-in-charge of medical store acting in place of the medical and dental store officer.

(g) *Adelaide*.—As for Newcastle.

(h) *Melbourne*.—As for Newcastle.

4. All stores are to be suitably cleaned and/or secured before packing for return to store.

5. All ports, other than Sydney and Fremantle, to return the collected stores, as and when convenient, to the R.A.N. Medical Store, Glebe, New South Wales, or Fremantle, Western Australia, whichever is the nearer.

6. All vessels "paying off" are to return all medical stores. Any medical treatment necessary is to be furnished by the depot at which destoring is taking place.

7. The medical store accounts with relevant vouchers from all vessels "paying off" are to be forwarded to the Director of Naval Medical Services, Navy Office, immediately the stores have been returned to the receiving authority. A forwarding address, to which communications regarding the account can be sent, is to be clearly indicated in the space provided, or endorsed on the cover of the account.

8. The more complete the information given in the account the quicker it can be audited and passed in office.

9. Unserviceable stores already surveyed and brought forward from a previous account or from an interim survey of the current account, are to be returned to store from the vessel paying off on a voucher marked "unserviceable" and separate from the main body of stores.

(1919/2/80.)

RESTRICTED.(FOR OFFICIAL USE ONLY.)

Commonwealth Navy Orders.

Navy Office, Melbourne,
13th November, 1945.

The following Orders, having been approved, are hereby promulgated for information and guidance, and necessary action.

By direction of the Naval Board,

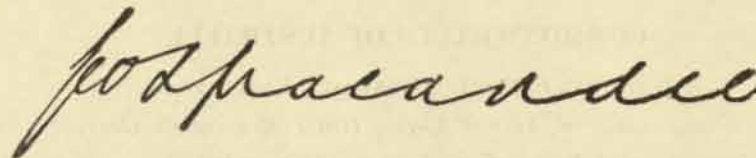

Secretary.

*The Commodore (Commanding H.M.A. Squadron,
and Commanding Officers of H.M.A. Ships,
Officers in Charge of H.M.A. Naval
Establishments, and others concerned.*

TABLE OF CONTENTS.

No.	Subject.
510.	H.M.A.S. "Taipan"—Paying off.
511.	H.M.A.S. "Warrawee"—Paying off.
512.	Orders under National Security Regulations.
513.	Naval Liaison Officer, Whyalla—Termination of Appointment.
514.	Guns Sub-Calibre Q.F. 2 pdr. L.A. Mark I—Supply for Use in Q.F. 4-in. Mark XVI* Guns.
515.	Accounting Procedure for Naval Stores in Stations and/or Services attached to H.M.A. Depots and Bases.
516.	Gramophone Records Suitable for "Doubling Round."—Supply.
517.	Honours and Awards—The 1939-45 Star, The Africa Star, The Atlantic Star, The Air Crew Europe Star, The Italy Star, The France and Germany Star, The Pacific Star, The Burma Star and the Defence Medal.

510.

H.M.A.S. "TAIPAN"—PAYING OFF.H.M.A.S. *Taipan* was paid off on 17th October, 1945.

(674/206/2977.)

511.

H.M.A.S. "WARRAWEE"—PAYING OFF.H.M.A.S. *Warrawee* was paid off on 24th September, 1945.

(674/206/3026.)

512.

ORDERS UNDER NATIONAL SECURITY REGULATIONS.

The following Orders under National Security Regulations are hereby promulgated for information:—

(a) *Commonwealth Gazette* No. 210, dated 30th October, 1945.**COMMONWEALTH OF AUSTRALIA.****NATIONAL SECURITY (GENERAL) REGULATIONS.***Navigation and Anchor Lights Order Revocation Order.*

In pursuance of Regulation 45 of the National Security (General) Regulations and Instrument of Delegation dated the twentieth day of August, 1945, and published in the *Gazette* on the twenty-eighth day of August, 1945, I, Louis Henry Keppel Hamilton, Chief of Naval Staff, hereby make the following Order:—

Citation.

1. This Order may be cited as the Navigation and Anchor Lights Order Revocation Order.

Revocation of the Navigation and Anchor Lights Order and Amending Orders.

2. The Orders specified in the Schedule to this Order are hereby revoked.

THE SCHEDULE.

Navigation and Anchor Lights Order, dated the seventeenth day of October, 1941, and published in the *Gazette* on the thirtieth day of October, 1941.

Navigation and Anchor Lights Order (No. 2), dated the twenty-third day of December, 1943, and published in the *Gazette* on the fifth day of January, 1944.

Navigation and Anchor Lights Order (No. 3), dated the fifth day of June, 1944, and published in the *Gazette* on the twenty-second day of June, 1944.

Navigation and Anchor Lights Order (No. 4), dated the twenty-first day of July, 1944, and published in the *Gazette* on the third day of August, 1944.

Dated this seventeenth day of October, 1945.

L. H. HAMILTON,
Chief of Naval Staff.

(b) *Commonwealth Gazette* No. 310, dated 30th October, 1945.**COMMONWEALTH OF AUSTRALIA.****NATIONAL SECURITY (GENERAL) REGULATIONS.***Order Under Regulation 45.*

In pursuance of Regulation 45 of the National Security (General) Regulations and Instrument of Delegation dated the twentieth day of August, 1945, and published in the *Gazette* on the twenty-eighth day of August, 1945, I, Louis Henry Keppel Hamilton, Chief of Naval Staff, hereby make the following Order:—

I hereby revoke the Navigation (Darkening Ship) Order, dated 17th October, 1941, and published in the *Gazette* on 30th October, 1941.

Dated this seventeenth day of October, 1945.

L. H. HAMILTON,
Chief of Naval Staff.

513.

NAVAL LIAISON OFFICER, WHYALLA—TERMINATION OF APPOINTMENT.

The appointment of the Naval Liaison Officer, Whyalla, was terminated on 23rd October, 1945.

(463/205/1194.)

514.

GUNS SUB-CALIBRE Q.F. 2 PDR. L.A. MARK I—SUPPLY FOR USE IN Q.F. 4-IN. MARK XVI* GUNS.

To improve the facilities for gunnery training in H.M.A. Ships mounting Q.F. 4-in. Mark XVI* guns for L.A. fire or for dual purpose of H.A. and L.A. fire (i.e., Sloops, Frigates and certain A.M.S. Vessels), guns sub-calibre Q.F. 2 pdr. L.A. Mark I have been obtained from the United Kingdom and are being distributed as follows, for issue to the ships concerned as required:—

S.A.S.O. Sydney	6-No.
N.A.S.O. Fremantle	4-No.
N.A.S.O. Darwin	2-No.
N.A.S.O. Maribyrnong	2-No.

2. Ammunition is available at Sydney and pools are being established at the remaining ports.

3. As far as possible, the sub-calibre guns are to be landed at the port of issue on completion of firings, but, if for any reason this is impracticable, they should be returned to the nearest Naval Armament Depot and the N.A.S.O. informed of the place from which they were drawn.

4. Attention is called to Annual Practice allowance, C.A.F.O. 1/45.
(490/201/1916.)

515.

**ACCOUNTING PROCEDURE FOR NAVAL STORES IN STATIONS
AND OR SERVICES ATTACHED TO H.M.A. DEPOTS AND BASES.**

With reference to paragraph 2 of Navy Order 682 of 1943, relative to the supply of consumable naval stores for Services and/or Stations attached to H.M.A. depots and bases, in some cases requirements of ordinary consumable maintenance stores cannot be met from stocks normally carried at the parent depot or base and are supplied direct from the appropriate naval store depot.

2. In such cases, the supply notes should be forwarded by the (Superintending) Naval Store Officer to the Supply Officer at the parent depot or base, who is to arrange for the notes to be endorsed and signed by the officer concerned at the Station or Service as to receipt of the items shown thereon and returned to him. After he has made a check to ensure that quantities demanded and supplied are reasonable, the Supply Officer should then file the supply notes in a separate guard at the parent depot or base. It is not necessary for such transactions to be shown on Forms A.S.156 or posted to the ledgers of the parent depot or base.

3. The above modified procedure is designed to eliminate unnecessary ledger entries, but should not be brought into operation at any base without prior Naval Board approval.

4. Navy Order 682 of 1943 will be amended in due course.
(612/212/2862.)

516.

**GRAMOPHONE RECORDS SUITABLE FOR "DOUBLING ROUND"—
SUPPLY.**

With reference to A.F.O. 3873/44, special gramophone records suitable for playing while "doubling round" are now available for use in the R.A.N.

2. Demands for requirements in accordance with the scale of allowances laid down in A.F.O. 3873/44 are to be forwarded to the Superintending Naval Store Officer, Sydney, as soon as possible by H.M.A. ships and naval establishments.

(612/201/5684.)

517.

**HONOURS AND AWARDS—THE 1939-45 STAR, THE AFRICA STAR,
THE ATLANTIC STAR, THE AIR CREW EUROPE STAR, THE
ITALY STAR, THE FRANCE AND GERMANY STAR, THE
PACIFIC STAR, THE BURMA STAR AND THE DEFENCE
MEDAL.**

The following amendments are to be made to Navy Order 400 of 1945:—

SECTION II.

Paragraph 7.

Add "He will not, however, be awarded the 1939-45 Star."

SECTION III.

Paragraph 2 (a).

For "in paragraphs (e), (f) and (g)" read "in paragraph 1 (a), (b) and (c)".

Paragraph 4 (a).

For "paragraphs (a)-(g) or (in the case of air crews) two months' service" read "paragraph 1 (a) and paragraph 2 (a) or (in the case of air crews) two months' service as defined in paragraph 2 (b)".

Paragraph 4 (e).

For "the Atlantic and France and Germany Star" read "the Atlantic and France and Germany Stars".

Paragraph 7 (b).

For "on or after 6th June, 1944" read "between 6th June, 1944 and 8th May, 1945".

SECTION IV.—RIBBONS.

Delete "Applications for the Rosette should be forwarded to the Secretary, Naval Board, Melbourne".

Add "Requirements of Rosettes should be obtained from the S.V.S.O., Royal Edward Victualling Yard, Sydney".

(448/201/1578.)

THE

HONORABLE AND SWARTH MORELL COLLEGE

THE COLLEGE WAS FOUNDED BY THE

STATE OF MASSACHUSETTS IN

1834 AND HAS SINCE THAT TIME

BEEN A LEADING INSTITUTION

OF HIGHER EDUCATION IN THE

MIDDLE WEST.

MEDAL

1880

THE

HONORABLE AND SWARTH MORELL COLLEGE

THE COLLEGE WAS FOUNDED BY THE

STATE OF MASSACHUSETTS IN

1834 AND HAS SINCE THAT TIME

BEEN A LEADING INSTITUTION

OF HIGHER EDUCATION IN THE

MIDDLE WEST.

MEDAL

RESTRICTED.(FOR OFFICIAL USE ONLY.)

Commonwealth Navy Orders.

Navy Office, Melbourne,
20th November, 1945.

The following Orders, having been approved, are hereby promulgated for information and guidance and necessary action.

By direction of the Naval Board,

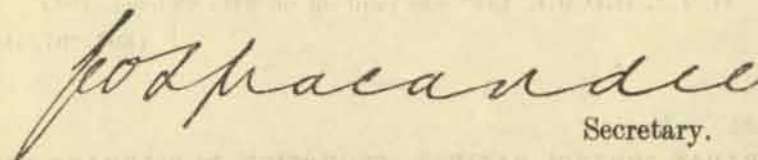
Secretary.

*The Commodore Commanding H.M.A. Squadron,
and Commanding Officers of H.M.A. Ships,
Officers in Charge of H.M.A. Naval
Establishments, and others concerned.*

TABLE OF CONTENTS.

No.	Subject.
518.	H.M.A.S. "Falie"—Paying off.
519.	H.M.A.S. "Stingray"—Paying off.
520.	H.M.A.S. "Goolgwai"—Paying off.
521.	H.M.A. H.D.M.L. 1340—Paying off.
522.	Radar Control Ratings—Promotion to Warrant Rank.
523.	U.S. Navy System of Feed Water Treatment—Adoption in the R.A.N.
524.	Transfer of Machinery and Plant.
525.	War Gratuity to Members of the Naval Forces.
526.	Supply of Beer to H.M.A. Ships and Naval Establishments.
527.	Supply of Officers' Uniforms, Including W.R.A.N.S. Officers' and R.A.N. Nurses.'
528.	Staff for Repatriation Medical Institutions.
529.	H.M.A. Ships Paying off—Return of Naval Armament, Gunmounting and Torpedo Stores.

518.

H.M.A.S. "FALIE"—PAYING OFF.H.M.A.S. *Falie* was paid off on 31st October, 1945.

(674/203/2212.)

519.

H.M.A.S. "STINGRAY"—PAYING OFF.H.M.A.S. *Stingray* was paid off on 30th October, 1945.

(603/246/5313.)

520.

H.M.A.S. "GOOLGWAI"—PAYING OFF.H.M.A.S. *Goolgwai* was paid off on 29th October, 1945.

(674/203/2261.)

521.

H.M.A. H.D.M.L. 1340—PAYING OFF.

H.M.A. H.D.M.L. 1340 was paid off on 24th October, 1945.

(603/297/648.)

522.

RADAR CONTROL RATINGS—PROMOTION TO WARRANT RANK.

Radar Control ratings are eligible for promotion to the Warrant Rank of Gunner under the same conditions as other seamen ratings laid down in K.R. and A.I., Articles 306 and 307.

(568/202/1064.)

523.

U.S. NAVY SYSTEM OF FEED WATER TREATMENT—ADOPTION IN THE R.A.N.

It has been decided to adopt the U.S. Navy System of feed water treatment in the following ships of the Royal Australian Navy:—*Australia*, *Hobart*, *Shropshire*, *Swan*, *Warrego*, and all River Class Frigates.

Pending the results of trials being carried out by the Admiralty in accordance with paragraph 9 of A.F.O. 1310/45, it is not intended to adopt this system in R.A.N. destroyers. Separate instructions will be issued should it be decided to adopt the system in any A.M.S. vessels.

2. The U.S. system should not however be adopted in any of the ships named above until the alteration and addition covering the fitting of permanent boiler blow down connections have been completed.

3. Full instructions regarding the use of U.S. Navy boiler compound will be issued from Garden Island with the necessary pattern 2541 boiler water testing sets.

(603/201/2249.)

524.

TRANSFER OF MACHINERY AND PLANT.

Naval Board approval is to be obtained before any item of machinery or workshop plant is transferred to a workshop or establishment other than that for which it was originally provided.

(524/201/2771.)

525.

WAR GRATUITY TO MEMBERS OF THE NAVAL FORCES.

In amplification of the information already communicated to all Discharging Depots, the following particulars in regard to the provisions of the *War Gratuity Act 1945*, are promulgated for general guidance.

2. *Gratuity*.—The rate of gratuity for overseas qualifying service is £3 15s. per month, and for general qualifying service other than overseas service, 15s. per month.

A gratuity is not claimable as a matter of right but is deemed to be a free gift by the Commonwealth in recognition of honourable service during the war and may be withheld or deferred by a prescribed authority or made subject to such terms and conditions as a prescribed authority thinks just and proper.

The Act provides that certain classes of members, such as those whose services are terminated on account of an offence or misconduct, may be disqualified from receiving a gratuity.

3. *Overseas Qualifying Service* consists of:—

- (a) Service abroad or in a seagoing ship on or after 3rd September, 1939, if the member had served continuously for 90 days, or an aggregate of 180 days in any twelve months;
- (b) all service abroad or in a seagoing ship if the member returned to Australia, or was discharged from a ship, owing to accepted injury or illness;
- (c) all service abroad or in a seagoing ship after having qualified as in (a) and (b);
- (d) time in hospital immediately following return to Australia or discharge from a seagoing ship owing to accepted injury or illness;
- (e) an additional 90 days after return from abroad or discharge from a seagoing ship or hospital if already qualified for overseas service, provided the member was not returned to Australia or discharged from the ship at the member's own request, or for disciplinary reasons or accepted injury or illness;
- (f) time of accrued leave for which the member has been paid.

If a member has qualified for overseas service and such qualifying service is less than twelve months, the period of overseas service will be deemed to be twelve months, unless the member has been returned to Australia or discharged from a ship at own request or for disciplinary reasons or for accepted injury or illness.

4. *General Qualifying Service* consists of:—

- (a) Overseas qualifying service;
- (b) full-time service other than overseas qualifying service on and from 7th December, 1941, if the member has already served six months' continuous service at that date;
- (c) service on and from the day following the date the member had served continuously for six months subsequent to 7th December, 1941;
- (d) time of accrued leave for which the member has been paid, but will not include any services rendered after the expiration of a period of twelve months subsequent to the cessation of hostilities.

5. *Special provisions as to qualifying service.*—Any period during which a member was not eligible to receive his full daily rate of pay, will not count for either general qualifying service or overseas qualifying service.

Any service in an overseas area of a special nature or short duration, such as voyage only, service or inspection duties, will not contribute to overseas qualifying service.

6. (a) *Date of entitlement* is the date on which a member or other person becomes entitled to be credited in the Register of War Gratuities with war gratuity in respect of the service of the member.

(b) The date of entitlement of mobilized personnel will be the date six months after the cessation of hostilities or, in the case of a member who is serving as a member on that date, either the date on which the member's service is terminated or the date twelve months after the cessation of hostilities, whichever is earlier.

(c) The date of entitlement for members of the Permanent Naval Forces will be the date to be proclaimed by the Governor-General as the date when the general qualifying service of a member of the Permanent Naval Forces shall cease.

7. *Date of Payment.*—Payment of gratuity will be made at the expiration of a period of five years and six months after the cessation of hostilities, except that where the gratuity payable is less than £10 or where payment of the gratuity is to be made to—

- (i) the widow of a member;
- (ii) the widowed mother of an unmarried member;
- (iii) the mother of a deceased member, if totally dependent on the member at the time of death or in necessitous circumstances; or
- (iv) a member who is blind or totally and permanently incapacitated,

payment of the gratuity may be made in whole or in part at any time after the date of entitlement that the prescribed authority decides.

8. *Application of War Gratuity towards purchase of home.*—At the request of a member and on the recommendation of a prescribed authority, the Minister may authorize the whole or portion of the gratuity to be transferred to the War Service Homes Commissioner or other approved authority, for the purpose of being credited by way of deposit or otherwise towards the cost of the erection or purchase of a dwelling house for the member.

9. *Interest on War Gratuity.*—Unless paid in full within three months from the date of entitlement, a member will be credited with compound interest on his gratuity at the rate of $3\frac{1}{4}$ per cent. per annum.

10. War Gratuity and Interest are not liable to income tax.

11. *Deceased Members.*—The Act contains special provisions applicable to gratuities payable in respect of deceased members whose deaths were due to war service. These provide—

- (i) for the payment of an additional seven months' gratuity, at the rate applicable at date of death, to be added to the gratuity that would otherwise be payable;
- (ii) that, where a member's death occurred prior to the expiration of the period of twelve months immediately following the cessation of hostilities and there was any one totally dependent on the member, a minimum of three years' gratuity at the overseas rate will be payable whether or not the member had, at the date of his death, any general qualifying service.

12. *Method of application.*—Application for gratuity will be made on special forms which will be issued to all members at the time of their discharge.

Members of Permanent Naval Forces will make application after the date referred to in paragraph 6 (c).

13. *Definitions.*—The following definitions are set out for guidance in respect of the foregoing:—

“Australia” means the area (including adjacent islands) which comprises the various States of the Commonwealth, together with the Australian Capital Territory and the Northern Territory;

“Australian Territories” means the Territories of Papua, New Guinea and Norfolk Island;

“Cessation of hostilities” means the date proclaimed by the Governor-General as the date from which hostilities shall be deemed to have ceased;

“Excepted injury or illness” means a self-inflicted injury or an injury or illness which, in the opinion of the prescribed authority, was due to or arose from—

- (a) the serious default or wilful act of a member; or
- (b) any occurrence happening during the commission of a serious breach of discipline;

“Member” means any male or female person who, at any time during the war, has been a member of the Commonwealth Naval, Military or Air Forces;

“Month” means a period of 30 days, provided that any period which is less than 30 days will be deemed to be one month;

“Oversea Area” means—

- (a) prior to 7th December, 1941—any area outside Australia and outside Australian Territories; or
- (b) on and after 7th December, 1941—any area outside Australia;

“Prescribed authority” means a person appointed a prescribed authority in accordance with the provisions of the *War Gratuity Act 1945*.

“Seagoing ship” does not include a depot ship or a ship principally employed on, or in connection with, port or harbour defence.

(487/202/763.)

(This Order will be reprinted for posting on Notice Boards.)

526.

SUPPLY OF BEER TO H.M.A. SHIPS AND NAVAL ESTABLISHMENTS.

The arrangements for the supply of beer to H.M.A. Ships and Naval Establishments have been revised and are promulgated hereunder for general information.

2. Beer is carried in Victualling Store Issuing Ships for issue, under the general directions of the respective Naval Officers-in-Charge, to H.M.A. Ships and shore bases in the New Guinea and Moluccas areas.

3. Such issues are made in complete cases and are restricted to a maximum of three bottles per head weekly for all personnel, including officers. Up to six weeks' requirements may be issued in bulk, if desired, to each ship or base which can provide satisfactory storage for that quantity, but the maximum stocks which may be maintained at any time are not to exceed two months' requirements. The foregoing represents the maximum quantity which may be supplied at any one time; it may be necessary on occasions, owing to freighting difficulties, to restrict supplies to a lower figure to ensure the equitable distribution of available stocks. In no circumstances are more than two bottles of beer to be issued to a rating on any one day.

4. Case supplies of beer from Issuing Ships are charged to sea-going ships at 9s. per dozen bottles net and to shore bases at 13s. 9d. per dozen bottles net. The issuing price of beer sold to messes in sea-going ships is 10d. per bottle, and, in shore bases, 1s. 3d. per bottle.

5. All profits resulting from bulk sales of beer from issuing ships are paid to the credit of the R.A.N. Central Canteen Fund after the completion of each voyage.

6. Subject to the approval of the Naval Board, reserves of beer may also be established on shore in the New Guinea and Moluccas areas, under the control of the respective Naval Officers-in-Charge, to supplement supplies available from Issuing Ships. Bulk issues will be made from these reserve stocks under the same conditions as apply to issues made ex Issuing Ships.

7. The Australian Army Canteens Service will continue to make supplies available to Naval personnel in advanced areas provided adequate notice of requirements is given. Such supplies will be confined to a maximum ration of three bottles per head per week.

8. In order to ensure that the available stocks of beer in the New Guinea and Moluccas areas are equitably distributed, it is important that the average consumption of beer from all sources in individual ships and shore bases does not exceed the authorized maximum allowance of three bottles per head per week. Commanding officers of ships and bases are to supervise closely all requisitions for supplies to ensure compliance with the foregoing.

9. To assist in eliminating duplication of supplies for individual messes, no orders for separate supplies are to be placed on merchants at mainland ports by ships and establishments in the New Guinea and Moluccas areas for transport in H.M.A. Ships, Store Issuing Ships, Store Carriers, or other vessels. Arrangements have been made with the Department of Trade and Customs whereby releases for such separate orders will not in future be approved.

10. Beer for messes and canteens in Naval Establishments within Australia will continue to be supplied either by the Australian Army Canteens Service or by direct purchase from brewers as hitherto. As a result of increased demands for supplies required for shipment to Service personnel serving outside Australia, it is necessary for supplies to Service messes and canteens on the mainland to be curtailed temporarily, and details of approved quotas for messes drawing supplies direct from brewers will be communicated to Naval Officers-in-Charge monthly.

11. Demands for bottled beer for export to Service personnel have imposed a heavy strain on the capacity of Australian brewers to produce bottled beer, and also on available production of bottles and other packaging materials. It is therefore essential that, wherever practicable, draught beer is used in preference to bottled beer in canteens and messes in shore establishments within Australia.

12. It is essential also that all empty bottles should be preserved to the utmost extent for return to the original source of supply. In the case of supplies made to ships and shore bases in the New Guinea and Moluccas areas empty bottles should be repacked in the original cases, together with the straw or fibre envelopes, for return to the ship or base from which supplies are next drawn, and ultimate return to the mainland. To enable this procedure to operate satisfactorily, care is to be exercised when opening cases to avoid damage and to ensure that they are entirely suitable for re-packing.

13. The percentage of empty beer bottles in cases returned by H.M.A. Ships receiving supplies from Service sources in the New Guinea and Moluccas areas has hitherto been much too low, and unless considerable improvement is effected, future supplies to these areas will necessarily be greatly prejudiced. In order to ensure the uninterrupted continuance of this amenity, Supply Officers in Store Issuing Ships and bases where stocks of beer are maintained have been instructed to restrict future issues on the basis of four full bottles for every three bottles returned. This procedure will result in the return of at least seventy-five complete cases of empty bottles for every one hundred cases issued. For the satisfactory control of returned empty bottles, ships should arrange, wherever practicable, to retain them on board until the next supply of full bottles is obtained from a Victualling Store Issuing Ship or other issuing source.

14. The proceeds of all returns of empty bottles and cases are credited to the R.A.N. Central Canteen Fund.

15. Navy Orders 538 of 1944 and 81 of 1945 are hereby cancelled.
(668/202/281.)

527.

SUPPLY OF OFFICERS' UNIFORMS, INCLUDING W.R.A.N.S. OFFICERS' AND R.A.N. NURSES'.

Uniforms for Officers, including W.R.A.N.S. Officers and R.A.N. Nurses, will not be available from Messrs. Anthony Horden and Sons Ltd., Brickfield Hill, Sydney, after 15th November, 1945, until further notice.

2. Navy Order 213 of 1945 is to be amended accordingly.

(434/215/1129.)

528.

STAFF FOR REPATRIATION MEDICAL INSTITUTIONS.

The Repatriation Commission is desirous of securing the services of male orderlies and female household workers at medical institutions controlled by them in the various States of the Commonwealth.

2. Applicants preferably should be persons who have served with the forces overseas. However, service with the forces in Australia only would not constitute a bar to employment.

3. Vacancies will occur in both temporary and classified (permanent) positions, and the general conditions of employment (long service, furlough, superannuation, recreation leave, sick leave, etc.) are similar to those obtaining in the Commonwealth Public Service.

4. Appointments to the classified positions and to certain temporary positions will be subject to the passing of a medical examination.

5. Orderlies' salaries at present are at the rate of £280 per annum. Opportunities may arise for the advancement of Grade I. orderly (range £292-£308 under an award).

6. Household workers are paid at £192 per annum under the Female Minimum Rates Regulations, and, where board and lodging is provided by the Department, a deduction of 17s. 6d. per week is made from salary.

7. Uniform allowance at the rate of £6 per annum is payable to classified orderlies and household workers. Temporary staff is provided with official uniforms, and all uniforms are laundered at departmental expense.

8. Hours of duty normally are 44 in a working week of 5½ days, where practicable.

9. Applications should be made, in writing, to the Deputy Commissioner of Repatriation in the State in which the applicant desires engagement. Full name, age and particulars of war service should be specified in the applications.

(406/201/478.)

529.

H.M.A. SHIPS PAYING OFF—RETURN OF NAVAL ARMAMENT, GUNMOUNTING AND TORPEDO STORES.

Navy Order 443 of 1945, paragraph 1 (a) is to be amended to read as follows:—

“(a) Ships Paying off for Disposal—All Ready Use gun and rocket ammunition 4” and below and all “exposed” Small Arm Ammunition is to be dumped in deep water prior to paying off. The remainder of the outfit of Naval Armament, Torpedo and Gunmounting stores is to be returned to the Naval Armament Torpedo, or Gunmounting Depot at the paying off port or, where such depots do not exist, to the Naval Officer-in-Charge for despatch to the nearest appropriate depot.”

(612/202/3754.)

RESTRICTED.(FOR OFFICIAL USE ONLY.)**Commonwealth Navy Orders.**

Navy Office, Melbourne,
27th November, 1945.

The following Orders, having been approved, are hereby promulgated for information and guidance and necessary action.

By direction of the Naval Board,

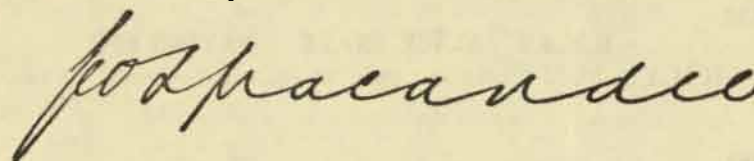

Secretary.

*The Commodore Commanding H.M.A. Squadron,
and Commanding Officers of H.M.A. Ships,
Officers in Charge of H.M.A. Naval
Establishments, and others concerned.*

TABLE OF CONTENTS.

No.	Subject.
530.	H.M.A.S. "River Snake"—Paying off.
531.	H.M.A.S. "Mother Snake"—Paying off.
532.	H.M.A.S. "Tiger Snake"—Paying off.
533.	H.M.A.S. "Black Snake"—Paying off.
534.	H.M.A.S. "Durraween"—Paying off.
535.	H.M.A.S. "Samuel Benbow"—Paying off.
536.	H.M.A.S. "Sea Mist"—Paying off.
537.	H.M.A.S. "Coombar"—Paying off.
538.	H.M.A.S. "Karina"—Paying off.
539.	H.M.A.S. "Wongalere"—Paying off.
540.	H.M.A.S. "Amohine"—Paying off.
541.	H.M.A.S. "Wato"—Paying off.
542.	H.M.A.S. "Lysander"—Paying off.
543.	H.M.A. M.L. 826—Paying off.
544.	H.M.A. H.D.M.L. 1352—Paying off.
545.	H.M.A. G.P.V. 962—Paying off.
546.	H.M.A.S. "Lusair"—Paying Off.
547.	H.M.A.S. "Huon"—Name Ship.
548.	R.A.N. Beach Unit.
549.	Signal Traffic.
550.	Fitting of Standard Grid Sights to O.Q.F. 40 m.m. Bofors Single Mountings.
551.	Fuzes Time Mechanical—Maintenance of Pre-Set Fuzes.
552.	Supply of Beer to H.M.A. Ships.

C.11227/45.

530. **H.M.A.S. "RIVER SNAKE"—PAYING OFF.**
H.M.A.S. *River Snake* was paid off on 2nd November, 1945.
(603/246/5529.)
531. **H.M.A.S. "MOTHER SNAKE"—PAYING OFF.**
H.M.A.S. *Mother Snake* was paid off on 3rd November, 1945.
(603/246/5560.)
532. **H.M.A.S. "TIGER SNAKE"—PAYING OFF.**
H.M.A.S. *Tiger Snake* was paid off on 3rd November, 1945.
(603/246/5560.)
533. **H.M.A.S. "BLACK SNAKE"—PAYING OFF.**
H.M.A.S. *Black Snake* was paid off on 3rd November, 1945.
(603/246/5560.)
534. **H.M.A.S. "DURRAWEEEN"—PAYING OFF.**
H.M.A.S. *Durraween* was paid off on 1st November, 1945.
(674/202/4085.)
535. **H.M.A.S. "SAMUEL BENBOW"—PAYING OFF.**
H.M.A.S. *Samuel Benbow* was paid off on 1st November, 1945.
(674/206/3033.)
536. **H.M.A.S. "SEA MIST"—PAYING OFF.**
H.M.A.S. *Sea Mist* was paid off on 9th November, 1945.
(603/246/5575.)
537. **H.M.A.S. "COOMBAR"—PAYING OFF.**
H.M.A.S. *Coombar* was paid off on 26th October, 1945.
(674/202/4079.)
538. **H.M.A.S. "KARINA"—PAYING OFF.**
H.M.A.S. *Karina* was paid off on 2nd November, 1945.
(603/246/5529.)
539. **H.M.A.S. "WONGALERE"—PAYING OFF.**
H.M.A.S. *Wongalere* was paid off on 31st October, 1945.
(603/246/4122.)

540. **H.M.A.S. "AMOHINE"—PAYING OFF.**
H.M.A.S. *Amohine* was paid off on 1st November, 1945.
(603/246/5530.)
541. **H.M.A.S. "WATO"—PAYING OFF.**
H.M.A.S. *Wato* was paid off on 12th November, 1945.
(603/235/839.)
542. **H.M.A.S. "LYSANDER"—PAYING OFF.**
H.M.A.S. *Lysander* was paid off on 8th November, 1945.
(603/246/5577.)
543. **H.M.A. M.L. 826—PAYING OFF.**
H.M.A. M.L. 826 was paid off on 31st October, 1945.
(603/294/1525.)
544. **H.M.A. H.D.M.L. 1352—PAYING OFF.**
H.M.A. H.D.M.L. 1352 was paid off on 31st October, 1945.
(603/297/649.)
545. **H.M.A. G.P.V. 962—PAYING OFF.**
H.M.A. G.P.V. 962 was paid off on 5th November, 1945.
(603/246/5561.)
546. **H.M.A.S. "LUSAIR"—PAYING OFF.**
With reference to Navy Order 100 of 1945, H.M.A.S. *Lusair* was paid off on 20th October, 1945.
(1937/2/348.)
547. **H.M.A.S. "HUON"—NAME SHIP.**
With reference to Navy Order 177 of 1943, H.M.A.S. *Huon* was paid off on 12th November, 1945.
2. The Motor Launch *Arcadia* has been commissioned as H.M.A.S. *Huon*.
(603/245/5500.)
548. **R.A.N. BEACH UNIT.**
The R.A.N. Beach Unit has been dispersed.
2. Correspondence and files have been turned over to H.M.A.S. *Gilolo*, to which correspondence is to be addressed in future.
3. Confidential Commonwealth Navy Order 7 of 1945 is cancelled.
(563/201/1763.)

549.

SIGNAL TRAFFIC.

A review of signal traffic shows that the volume has actually increased since the cessation of hostilities and that the amount of traffic being handled is resulting in excessive delays to important messages.

2. Whilst this increase can, in a measure, be attributed to post-war phases, e.g., demobilization, paying off of ships, transport of P.O.Ws., it is evident that many matters now being communicated in signal form, particularly those sent by air mail, courier and hand, could be dealt with by letter.

3. Commanding Officers of Ships and Shore Authorities are to take necessary action to ensure that signals are restricted to matters which warrant despatch by this channel of communication and that, having regard to the number of circuits over which multiple address messages must be passed, "information" addresses are confined to those which are essential.

4. Navy Order 207 of 1944 and A.C.N.B.'s signal 191151 September are relevant.

(2037/2/1583.)

550.

FITTING OF STANDARD GRID SIGHTS TO O.Q.F. 40 m.m. BOFORS SINGLE MOUNTINGS.

The parts for converting the eyeshooting sights of single 40 m.m. Bofors guns to Naval type described in Navy Order 129 of 1945 are now available.

2. It is not now intended to supply without demand, and ships concerned are to forward demands to the Gunmounting Depot, Garden Island, stating clearly whether the parts are required for fitting to Sight Bars Mark II or to Sights correctional Mark V.

3. The sights of mountings in store are to be converted before mounting in ships.

4. Navy Orders 548 of 1944 and 129 of 1945 refer.

(490/217/20.)

551.

FUZES TIME MECHANICAL—MAINTENANCE OF PRE-SET FUZES.

Experience has shown that fuzes time No. 211, when set for lengthy periods in temperatures of over 95° F., cannot be re-set or set to safe with service key or fuze setter.

2. To overcome this "setting up", routine setting of these fuzes, when stowed in ready use lockers and subjected to high temperatures, is to be carried out at intervals of not less than twelve or greater than thirteen weeks.

3. Navy Order 142 of 1945 is cancelled.

(471/209/1405.)

552.

SUPPLY OF BEER TO H.M.A. SHIPS.

With reference to Navy Order 526 of 1945, it is notified that, in order to ensure the equitable distribution of available supplies, drawings of bottled beer by messes in all seagoing H.M.A. Ships are, in future, to be restricted to a maximum of three bottles per head per week.

2. Collectors of Customs in all States have been instructed by the Comptroller-General to take steps to ensure that beer cleared under Excise Tariff Item 18 or shipped as ship's stores for use by Navy personnel, does not exceed this approved maximum allowance.

3. It will be necessary in future for Commanding Officers, when requisitioning for supplies of beer under Excise Tariff Item 18 or for shipment as ship's stores, to furnish the under-mentioned particulars:—

- (a) the number of personnel for whom supplies are required and the period covered by the requisition; or, alternatively,
- (b) a certificate to the effect that the quantity of beer applied for, will not be in excess of 80 oz. per man per week during the period for which it is intended to be used.

(1990/4/221.)

LETTER OF REPLY TO H.M. A. SMITH

Dear Sir,

I have the pleasure to acknowledge the receipt of your letter of the 10th inst. in relation to the proposed purchase of the land in question. I am sorry to hear that you are unable to purchase the land at the price offered, but I am sure that you will be able to find other suitable land for your purposes.

I am, Sir, very respectfully,
 Yours truly,
 J. H. Smith

RESTRICTED.(FOR OFFICIAL USE ONLY.)**Commonwealth Navy Orders.**

Navy Office, Melbourne,
4th December, 1945.

The following Orders, having been approved, are hereby promulgated for information and guidance, and necessary action.

By direction of the Naval Board,

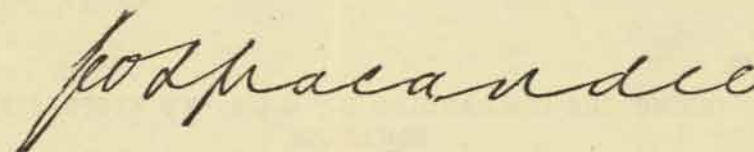

Secretary.

*The Commodore Commanding H.M.A. Squadron,
and Commanding Officers of H.M.A. Ships,
Officers in Charge of H.M.A. Naval
Establishments, and others concerned.*

TABLE OF CONTENTS.

No.	Subject.
553.	H.M.A. Ships—Paying Off.
554.	Commodore Commanding His Majesty's Australian Squadron.
555.	Orders under National Security Regulations.
556.	Port Directors.
557.	Post-Discharge Malaria.
558.	Members of the Naval Forces Undergoing Detention or Imprisonment—Maintenance of their Wives or Dependants—Revised Procedure.
559.	Naval Stores—Interstate and Overseas Shipments and Consignments by Rail and Air Freight to Naval Establishments in Victoria.
560.	Sales of Stores and Property.
561.	Accounting for Naval Stores in Coastal Craft.
562.	Royal Australian Naval Women's Services—Uniform and Clothing—Authorized Kits.
563.	R.A.N. Women's Auxiliary Services—Special Issue of Coupons for Purchase of Nightwear.
564.	Unsweetened Condensed Milk—Batch Markings.
565.	Telegrams to Naval Personnel.
566.	Outfit Gratuities for Officers of the Naval Reserve Forces.

553.

H.M.A. SHIPS—PAYING OFF.

The following H.M.A. Ships were paid off on the dates indicated:—

<i>H.M.A. Ship.</i>	<i>Date of Paying Off.</i>
M.L. 813	1st October, 1945.
M.L. 429	12th October, 1945.
M.L. 814	12th October, 1945.
M.L. 821	12th October, 1945.
H.D.M.L. 1338	26th October, 1945.
M.L. 815	7th November, 1945.
<i>Olive Cam</i>	14th November, 1945.
<i>Mary Cam</i>	14th November, 1945.
M.L. 812	19th November, 1945.
M.L. 824	19th November, 1945.
<i>Avonita</i>	19th November, 1945.

(603/247/1957.)

554.

COMMODORE COMMANDING HIS MAJESTY'S AUSTRALIAN SQUADRON.

The Broad Pennant of the Commodore Commanding His Majesty's Australian Squadron was transferred from H.M.A.S. *Shropshire* to H.M.A.S. *Hobart*, on 17th November, 1945.

(1804/2/110.)

555.

ORDERS UNDER NATIONAL SECURITY REGULATIONS.

The following Orders under National Security Regulations are hereby promulgated for information:—

(a) *Commonwealth Gazette*, No. 223, dated 19th November, 1945.)**COMMONWEALTH OF AUSTRALIA.****NATIONAL SECURITY (GENERAL) REGULATIONS.***Navigation (Control of Public Traffic) Order Revocation Order.*

In pursuance of regulation 45 of the National Security (General) Regulations and Instrument of Delegation dated the twentieth day of August, 1945, and published in the *Gazette* on the twenty-eighth day of August, 1945, I, Louis Henry Keppel Hamilton, Chief of Naval Staff, hereby make the following Order:—

CITATION.

1. This Order may be cited as the Navigation (Control of Public Traffic) Order Revocation Order.

REVOCATION OF THE NAVIGATION (CONTROL OF PUBLIC TRAFFIC)**ORDER AND AMENDING ORDERS.**

2. The Orders specified in the Schedule to this Order are hereby revoked.

THE SCHEDULE.

Navigation (Control of Public Traffic) Order, dated the twenty-sixth day of October, 1943, and published in the *Gazette* on the twelfth day of November, 1943.

Navigation (Control of Public Traffic) Order (No. 2), dated the twenty-eighth day of February, 1944, and published in the *Gazette* on the eighth day of March, 1944.

Navigation (Control of Public Traffic) Order (No. 3), dated the sixteenth day of August, 1944.

Navigation (Control of Public Traffic) Order (No. 4), dated the eighth day of September, 1944.

Dated this first day of November, 1945.

L. H. K. HAMILTON,

Chief of Naval Staff.

(b) *Commonwealth Gazette*, No. 223, dated 19th November, 1945.)**COMMONWEALTH OF AUSTRALIA.****NATIONAL SECURITY (GENERAL) REGULATIONS.***Order under Regulation 47.*

In pursuance of regulation 47 of the National Security (General) Regulations and Instrument of Delegation dated the twentieth day of August, 1945, and published in the *Gazette* on the twenty-eighth day of August, 1945, I, Louis Henry Keppel Hamilton, Chief of Naval Staff, hereby make the following Order:—

I hereby revoke the Merchant Ships (Passive Defence) Order, dated the fourteenth day of April, 1943, and published in the *Gazette* on the twenty-seventh day of April, 1943.

Dated this first day of November, 1945.

L. H. K. HAMILTON,

Chief of Naval Staff.

(c) *Commonwealth Gazette*, No. 223, dated 19th November, 1945.)**COMMONWEALTH OF AUSTRALIA.****NATIONAL SECURITY (GENERAL) REGULATIONS.***Order under Regulation 47.*

In pursuance of regulation 47 of the National Security (General) Regulations and Instrument of Delegation dated the twentieth day of August, 1945, and published in the *Gazette* on the twenty-eighth day of August, 1945, I, Louis Henry Keppel Hamilton, Chief of Naval Staff, hereby make the following Order:—

I hereby revoke the Protection of Shipping (Defensive Armament) Order, dated the twenty-eighth day of October, 1941, and published in the *Gazette* on the fifth day of November, 1941.

Dated this first day of November, 1945.

L. H. K. HAMILTON,

Chief of Naval Staff.

(d) *Commonwealth Gazette*, No. 223, dated 19th November, 1945.)

COMMONWEALTH OF AUSTRALIA.

NATIONAL SECURITY (GENERAL) REGULATIONS.

Order under Regulation 47.

In pursuance of regulation 47 of the National Security (General) Regulations and Instrument of Delegation dated the twentieth day of August, 1945, and published in the *Gazette* on the twenty-eighth day of August, 1945, I, Louis Henry Keppel Hamilton, Chief of Naval Staff, hereby make the following Order:—

I hereby revoke the Protection of Exposed Personnel (Merchant Ships) Order, dated the third day of March, 1942, and published in the *Gazette* on the twelfth day of March, 1942.

Dated this first day of November, 1945.

L. H. K. HAMILTON,
Chief of Naval Staff.

(e) *Commonwealth Gazette*, No. 223, dated 19th November, 1945.)

COMMONWEALTH OF AUSTRALIA.

NATIONAL SECURITY (GENERAL) REGULATIONS.

Order under Regulation 47.

In pursuance of regulation 47 of the National Security (General) Regulations and Instrument of Delegation dated the twentieth day of August, 1945, and published in the *Gazette* on the twenty-eighth day of August, 1945, I, Louis Henry Keppel Hamilton, Chief of Naval Staff, hereby make the following Order:—

I hereby revoke the Protection of Shipping (Accommodation for Defence Personnel) Order, dated the fourth day of November, 1943, and published in the *Gazette* on the tenth day of November, 1943.

Dated this first day of November, 1945.

L. H. K. HAMILTON,
Chief of Naval Staff.

556.

PORT DIRECTORS.

A R.A.N. Port Director was appointed at Labuan on 1st November, 1945.

2. The Port Directors at Torokina, Oro Bay, Lae, Balikpapan, Tarakan, Aitape, and Jacquinot Bay have been withdrawn.

3. R.A.N. Port Directors are in operation only at Milne Bay, Langemak, Madang, Hollandia, Koepang, Biak and Port Moresby.

4. Navy Orders 425, 514, 540 and 678 of 1944 and 166, 290, 392, 448 and 476 of 1945 are cancelled.

(1937/2/348.)

557.

POST-DISCHARGE MALARIA.

The Repatriation Commission will accept responsibility for providing any treatment necessary in respect of the first attack of malaria suffered by an ex-member of the R.A.N. after his discharge from the Navy.

2. During such treatment, the Commission will institute inquiries as to eligibility or otherwise for the treatment of any subsequent attacks of malaria.

3. On the first occasion after his discharge that an ex-member becomes ill with malaria, he should—

(a) if resident in a capital city—report to the Repatriation Department's branch office or general hospital, either in person or by telephone, when immediate examination and treatment will be arranged;

(b) if resident in the country—report to and request treatment from the nearest Repatriation local medical officer, who will send a report to the Repatriation Department. It will be necessary for the ex-member to identify himself by production of his discharge certificate.

4. (a) If it is not possible so to report, the ex-member should consult and request treatment from his local civilian doctor, and, provided prompt advice is sent by the doctor or the ex-member to the Repatriation Department, the Commission will assume full responsibility for the payment of medical fees, hospital fees and the cost of drugs.

(b) Arrangements for any further treatment will be notified to the ex-member by the Repatriation Commission as soon as possible.

5. Information regarding the treatment of malaria, with particular reference to ex-service personnel, has been sent by the Commonwealth Department of Health to civil medical practitioners.

6. In view of the foregoing, it is unnecessary for any member to be examined by a final medical board at the time of his discharge merely on account of a history of malaria. If the member has had an attack during his service, it will be on record in his medical history. Whether or not the member has had an attack during his service, he will be cared for by the Repatriation Commission should he develop an attack of malaria after his discharge.

(527/201/1081.)

(This Order will be reprinted for posting on Notice Boards.)

558.

MEMBERS OF THE NAVAL FORCES UNDERGOING DETENTION OR IMPRISONMENT—MAINTENANCE OF THEIR WIVES AND/OR DEPENDANTS—REVISED PROCEDURE.

In cases where members of the Naval Forces in receipt of marriage and/or dependant allowances are detained awaiting trial and subsequently sentenced to imprisonment or detention with consequent cessation of pay, allotments are to be declared at, or reduced to, the standard

rate plus marriage allowance or dependant allowance from the pay period following the date of commencement of the waiting trial period. In all such cases, marriage and/or dependant allowances are to be credited and the full amount of the allotment is to be charged. (In the case of recovered deserters, the allowance is to be credited from the date of recovery from desertion subject to the declaration of a fortnightly allotment at a pro rata rate from that date, to be increased to the standard rate plus the allowance from the next full fortnightly pay period.) When such a member is to be retained in the Service on completion of his period of detention or imprisonment, the debit balance so accrued is to be recovered in suitable instalments upon his return to duty.

2. In cases where such members are subsequently approved to be discharged on completion of sentence, the Commonwealth will accept to a degree liability for the maintenance of their wives and/or dependants if the members are—

- (a) serving sentences in Service detention barracks whether convicted of a "civil" or "Service" offence, or
- (b) serving sentences in a civil gaol as a result of sentences by Service courts.

3. The dependants of members serving, in civil gaols, sentences imposed by civil courts for civil offences, will be the direct responsibility of the State in which they are residing, assistance being rendered at the State rate in force.

4. Action will be taken in Navy Office to advise the member's wife or dependant of the fact that he is to be discharged and of the particulars in regard to future payments of allotment.

In all such cases, payment of allotment will be continued for two pay days from the date of such notification to the allottee, at the standard rate of allotment plus marriage allowance or dependant allowance. In cases as per paragraph three above, payment of allotment will be stopped after the two pay periods and the ship in which the member's pay account is held will be advised accordingly.

In cases covered by paragraph 2 above, allotments to wives (including dependent females) with children will be reduced after the two pay periods to a rate equal to the rate of marriage and/or dependant allowances then being credited to the member (i.e., excluding the allotment from active pay). No means test will be applied to such payments.

Allotments payable to wives (including dependent females) without children and to other dependants (e.g., mothers, &c.) will be continued, after the two pay periods referred to, only where the allottee is totally dependent on the member and is unable to work.

5. Action taken in Navy Office regarding allotment payments will be communicated to H.M.A. Ships carrying such members' pay accounts. In all cases, marriage and/or dependant allowances are to be credited to the date of stoppage of payment of the allotment.

6. In those cases where reduced allotments are being paid, it will be necessary, on the release of the member from detention or imprisonment, for H.M.A. Ship carrying the member's pay account to forward Form A.S. 54 to Navy Office, stopping his allotment at the pay day prior to his discharge from the R.A.N.

7. The liability of the Commonwealth for payments under the foregoing ceases on the member's release from detention or imprisonment or on date to be determined, but not later than six months after the date proclaimed under the Defence Act as the end of the state of war.

8. Navy Order 85 of 1945 is hereby cancelled.

(556/207/5648.)

559.

NAVAL STORES—INTERSTATE AND OVERSEAS SHIPMENTS AND CONSIGNMENTS BY RAIL AND AIR FREIGHT TO NAVAL ESTABLISHMENTS IN VICTORIA.

With reference to paragraph 2 of Navy Order 35 of 1945, all interstate and intra-state consignments by sea and air of Naval Stores forwarded to Melbourne for Navy Office, Flinders Naval Depot, Port Melbourne and Williamstown Naval Depots, the R.A.N. Mine Depot, Swan Island and H.M.A. Ships are, in future, to be consigned to the Officer-in-Charge, Naval Store Depot, Port Melbourne.

2. Consignments by goods and passenger rail to Flinders Naval Depot and the R.A.N. Mine Depot, Swan Island, are to be consigned direct to those establishments. Packages forwarded by rail for Navy Office, Port Melbourne and Williamstown Depots and H.M.A. Ships at Melbourne are to be consigned to the Officer-in-Charge, Naval Store Depot, Port Melbourne.

3. All consignments by sea or rail for the Naval Dockyard, Williamstown, are to be consigned direct to the General Manager.

4. C.O.R. Article 531, Part (a) will be amended in R.I. Series.

5. Navy Order 288 of 1945 is cancelled.

(612/201/5358.)

560.

SALES OF STORES AND PROPERTY.

Attention is directed to Article 336 of the Naval Account Regulations and Instructions, which provides that all authorities issued from Navy Office to sell stores will contain a sales authority number and that, in the event of such a number not being quoted in the Navy Office communication, it should be immediately applied for.

2. This requirement applies to disposals and covers all types of property authorized for sale.

3. The authority to dispose of property by sale is vested in the Minister and certain officers of Central Administration, as shown in Article 218, Naval Financial Regulations and Instructions, and stores, &c., should not be sold without the approval of the appropriate authority first being obtained.

4. Care should always be taken to see that the sales authority number is noted in Receivers' Statements and other documents relating to sale.

(414/201/542.)

561.

ACCOUNTING FOR NAVAL STORES IN COASTAL CRAFT.

Difficulties in accounting for naval stores frequently arise in small craft in which inventory naval store accounts in accordance with Navy Order 632 of 1943 are in use, consequent on the installation of new equipment and modifications to existing equipment being effected by base staffs without the knowledge of the appropriate storekeeping officer.

2. The attention of all concerned is drawn to the necessity for requisite vouchers to be raised in all cases in which the supply or return of naval stores is involved, and equipment is not to be removed from or fitted in such vessels without reference to the storekeeping officer concerned.

(612/212/3324.)

562.

ROYAL AUSTRALIAN NAVAL WOMEN'S SERVICES—UNIFORM AND CLOTHING—AUTHORIZED KITS.

Personnel of the R.A.N. Nursing Service are in future to receive a gratuitous issue of 1 No. khaki shirt and 1 No. khaki skirt in lieu of the blue cesarine summer dress.

2. Appointees to Darwin are to be gratuitously issued, in addition, with 2 No. long sleeved shirts and 2 prs. slacks.

3. Page 2 of Navy Order 375 of 1943 is to be amended accordingly.

(434/201/3784.)

563.

R.A.N. WOMEN'S AUXILIARY SERVICES—SPECIAL ISSUE OF COUPONS FOR PURCHASE OF NIGHTWEAR.

Consequent upon alteration to the Australian coupon scale, approval for the special issue of clothing coupons to members of the R.A.N. Women's Auxiliary Services for the purchase of nightwear has been withdrawn as from 15th November, 1945.

2. Navy Order 64 of 1945 is cancelled.

(350/201/79.)

564.

UNSWEETENED CONDENSED MILK—BATCH MARKINGS.

The process used by the Federal Milk Pty. Ltd. for the manufacture of condensed milk is now virtually continuous, with the result that milk is processed in one large batch each day instead of a number of small batches.

2. Accordingly, the batch marking for this firm's supply will, in due course, be the date of manufacture only.

(668/212/622.)

565.

TELEGRAMS TO NAVAL PERSONNEL.

Arrangements have been made with the P.M.G.'s Department for the transmission of all classes of telegrams to personnel serving in H.M. and H.M.A. Ships, provided that such ships are in a port in the mainland of Australia.

2. The Superintendent of Telegraphs in each State will be advised by Navy Office of all of H.M. and H.M.A. Ships which are in port in Australia and for which telegrams may be accepted. The list will be kept up to date by advice from Navy Office.

3. Messages will be delivered to the Naval Officer-in-Charge of the port where the ship is located, and it will be the responsibility of the Naval Officer-in-Charge to ensure that delivery is effected as early as practicable.

4. It is desirable that personnel should advise relatives and friends of the foregoing arrangements, which will operate forthwith.

5. It will not be possible to provide a similar service for personnel in ships outside Australia until civil control of communications overseas has been re-established. "Conav" messages: i.e., messages of an urgent private nature will, however, continue to be accepted, and will be despatched through naval channels—*vide* Navy Order 326 of 1945.

(443/203/410.)

(This Order will be reprinted for posting on Notice Boards.)

566.

OUTFIT GRATUITIES FOR OFFICERS OF NAVAL RESERVE FORCES.

With reference to the following Regulations and Instructions:—

- (a) R.A.N.R.(S)—Article 50, clause (3),
- (b) R.A.N.R.—Article 193, clause (2), and
- (c) R.A.N.V.R.—Article 25, clause (4),

it has been approved as a temporary measure, for a uniform rate of outfit gratuity of £37 to be paid to Reserve Officers on first appointment to officer rank on or after 1st May, 1945.

2. The payment of the outfit gratuity, which does not include the allowance payable for the provision of khaki tropical clothing, is subject to a certificate that the officer is in possession of the full war-time uniform appropriate to his rank. This certificate should be signed by the Commanding Officer and accompany the ship's ledger into office.

(434/215/1123.)

CONFIDENTIAL REPORT TO THE BOARD

The following information was obtained from a confidential source who has provided reliable information in the past. It is being provided to you for your information and is not to be disseminated outside of your office.

The source has advised that [redacted] has been observed in the vicinity of [redacted] on [redacted] at approximately [redacted] hours. The source has not been able to identify the individual and is unable to provide any further details.

This information is being provided to you for your information and is not to be disseminated outside of your office. If you have any questions or need further information, please contact the source at [redacted].

RESTRICTED.(FOR OFFICIAL USE ONLY.)

Commonwealth Navy Orders.

Navy Office, Melbourne,
11th December, 1945.

The following Orders, having been approved, are hereby promulgated for information and guidance, and necessary action.

By direction of the Naval Board,

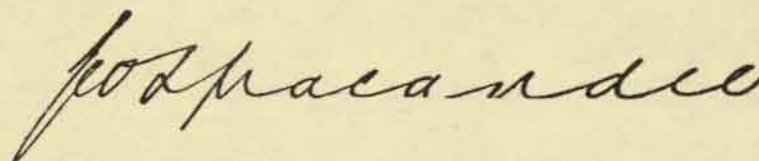

Secretary.

*The Commodore Commanding H.M.A. Squadron,
and Commanding Officers of H.M.A. Ships,
Officers in Charge of H.M.A. Naval
Establishments, and others concerned.*

TABLE OF CONTENTS.

No.	Subject.
567.	Naval Officer-in-Charge, Flinders Naval Depot—Change of Title.
568.	Certificates of Service.
569.	Radar Plot Branch—Opportunities for Attaining Warrant Rank.
570.	Furlough or Extended Leave—Members being Demobilized.
571.	Disposal of Books, Printed Matter, etc., Held in H.M.A. Ships, etc. Paying Off.
572.	Service System Canteens—Rendition of Reports on Paying Off.
573.	Prevention of Fire in Motor Boats—Wearing of Protective Clothing.
574.	Motor Tarnsport—Prevention of Theft.
575.	Distinguishing Pendants—Frigates and A.M.S. Vessels (Corvettes).
576.	Kit Bags, Hammocks, etc.—Losses During Transport—Labelling and Marking.
577.	Special Christmas Fare, 1945.
578.	General Mess Balances in H.M.A. Ships and Shore Establishments—Waivure as from 31st March, 1945.
579.	Medical Staff—Repatriation Commission.
580.	Officers' Working Dress.

567.

**NAVAL OFFICER-IN-CHARGE, FLINDERS NAVAL DEPOT—
CHANGE OF TITLE.**

With reference to Navy Order 231 of 1942, the Officer-in-Charge, Flinders Naval Depot and the Commanding Officer, H.M.A.S. *Cerberus* will, in future, be known by the general title of Commodore Superintendent of Training, Flinders Naval Depot, and letters are to be addressed accordingly.

2. Telegrams should be addressed "Commodore, Flinders Naval Depot".

3. The title of Naval Officer-in-Charge, Flinders Naval Depot, is no longer to be used.

(549/201/196.)

568.

CERTIFICATES OF SERVICE.

Perusal of certificates of service received in Navy Office shows that in a large number of cases, the document itself and its enclosures have not been correctly compiled.

2. The most common omissions from certificates of service are character and efficiency assessments and notation of award of good conduct badges. In regard to the enclosures—History Sheets, Forms A.S.264, and A.S. 239A Conduct Sheet (in respect of Notes 4, 5 and 8) also frequently fail to include necessary notations. Delay often takes place in recommending the removal of "R" from the certificates of recovered deserters, and the re-advancement of ratings summarily dis-rated. Cases have arisen, e.g., where acting engine room artificers, 4th class, have been awarded engine room watchkeeping certificates although they are not eligible therefor.

3. It is essential that a member's certificate of service contains a complete and accurate record of his service. Commanding Officers should take immediate steps to have all certificates of service and enclosures thereto carefully inspected and corrected or brought up to date as requisite.

(453/202/1032.)

569.

**RADAR PLOT BRANCH—OPPORTUNITIES FOR ATTAINING
WARRANT RANK.**

As at present constituted, the Radar Plot Branch consists mainly of ratings serving under "hostilities only" engagements. After the war, however, its personnel must necessarily consist of ratings of the Permanent Naval Forces.

2. For the filling of certain posts in connection with A.I.O. and Radar training and also to provide a suitable incentive to ratings of the branch, the Naval Board has decided to make provision in the post-war organization for the promotion to warrant rank and above, of suitable and recommended ratings of the Radar Plot Branch.

3. Full details of the scheme, together with the designation of the new warrant officers, will be promulgated in due course.

(568/202/1056.)

570.

**FURLOUGH OR EXTENDED LEAVE—MEMBERS BEING
DEMobilized.**

Applications for payment in lieu of furlough or extended leave in accordance with Articles 211 and 212 of Naval Financial Regulations and Instructions are being received at Navy Office in respect of members who are not eligible.

2. It is therefore promulgated for general information that these awards may be made only in respect of members of the Permanent Naval Forces who would normally serve under the usual engagements in the Royal Australian Navy for at least 20 years, or who may, due to circumstances beyond their control (e.g., on account of discharge invalidated), be precluded from completing that period of service. They are not made in the case of members who joined for "hostilities only" or members of Royal Australian Fleet Reserve or Royal Australian Naval Reserve. The following requirements are necessary:—

- (a) Completion of 20 years' continuous service, or
- (b) completion of at least 4 years' service where the member's discharge is due to death or invaliding, or
- (c) completion of 12 years' service where retiring age has been reached.

(Note.—In accordance with the principle governing the grant of furlough or extended leave, it is a condition that a member discharged on account of death or invaliding must have been eligible to complete 12 years' service before he would be discharged on reaching the retiring age. This condition was suspended in respect of members who served in the Royal Australian Navy during the period of hostilities.)

3. Completion of engagements totalling 12 or 17 years does not of itself qualify, and members who take their discharge at those stages do not receive any payment in lieu of extended leave. It should be noted that members who did not re-engage but who were retained for war service and may have completed nearly 20 years' service are not eligible for furlough unless they have reached the retiring age.

Any such members may apply to have their demobilization deferred so as to permit completion of the full qualifying period of 20 years or until retiring age is reached if such could eventuate within the period allowed for demobilization.

4. Other than those members referred to in the latter part of paragraph 3, no payment in lieu of extended leave may be made to members who are discharged under the demobilization arrangements.

(556/241/1114.)

571.

DISPOSAL OF BOOKS, PRINTED MATTER, ETC., HELD IN H.M.A. SHIPS, ETC. PAYING OFF.

With reference to Navy Order 413 of 1945, the following procedure is to be observed in regard to the disposal of books, printed matter, &c., in vessels being paid off and in Shore Establishments and Services being closed down:—

- (a) All books of Reference and O.U. Publications held on board are to be packed and forwarded to the Superintending Naval Store Officer, Sydney.
- (b) Admiralty Fleet Orders and variants for 1944 and 1945 are also to be returned to the Superintending Naval Store Officer, Sydney. Bound volumes of A.F.O.'s and variants dated prior to 31st December, 1943 (B.R.121) are to be destroyed, a certificate of destruction on Form A.S.331 being prepared in accordance with B.R.4, Article 15. Unbound orders for 1942 and 1943 are also to be destroyed.
- (c) The provisions of the above-mentioned Navy Order as regards muster and return to store of all Books of Reference and O.U. publications on permanent loan, closing of accounts, &c., are generally applicable, except that all closed B.R. and O.U. accounts are to be forwarded to the Officer-in-Charge, Naval Store Depot, Esplanade West, Port Melbourne, under cover of a letter of advice.
- (d) Unused printed forms, stationery and office requisites are to be returned to the Base Supply Officer or (Suptg.) Naval Store Officer, as appropriate, and a receipt obtained on forms A.S.331 which should be stamped "not for ledger". Only such quantities of stationery, &c., as may be required for use whilst paying off should be retained on board.

(612/201/5916.)

572.

SERVICE SYSTEM CANTEENS—RENDITION OF REPORTS ON PAYING OFF.

Special attention is drawn to section A, paragraph (viii) (j) of Navy Order 469 of 1945, which requires rendition to the Director of Victualling of reports of Service System Canteens on paying off.

2. Commanding Officers of all ships and establishments in which such canteens are operating are to ensure that final canteen accounts are carefully compiled in sufficient time to permit of complete audit by representatives of the Canteen Committee for presentation to the Committee before paying off.

3. In particular, all outstanding accounts, including any liability for advances from public funds, are to be settled before paying off, and stocks and other assets realized or disposed of in accordance with the decisions of the Committee and the Commanding Officer's approval.

4. The report forwarded to the Director of Victualling is to be accompanied by a final balance sheet and a statement certified by the Commanding Officer showing the disposal of assets, including stock and cash.

5. When determining the disposal of cash assets, the Canteen Committee of each ship or establishment is requested to give consideration to making a donation to the R.A.N. Relief Fund, the purposes of which are outlined in Navy Order 264 of 1941.

6. Items of canteen equipment originally received as gifts or presentations from charitable or patriotic organizations are not to be regarded as the property of the canteen, but are to be accounted for and disposed of strictly in accordance with C.O.R., Article 396.

7. The attention of Commanding Officers and Canteen Committees is drawn to A.F.O. 4835/45, and the procedure outlined therein is to be observed as a general guide to ensure the efficient audit of canteen accounts.

8. It is emphasized that it is the direct responsibility of each Commanding Officer to exercise the closest supervision in order to ensure strict compliance with the foregoing, when, for any reason, a Service System Canteen is terminated.

9. Navy Order 482 of 1945 is cancelled.

(427/201/1015.)

573.

PREVENTION OF FIRE IN MOTOR BOATS—WEARING OF PROTECTIVE CLOTHING.

An explosion of petrol vapour in the engine room of one of H.M.A. motor boats occurred recently, resulting in the death of two ratings from extensive burns.

2. The ratings concerned were not wearing overall protective clothing at the time and the Board of Enquiry considered that the extent of the burns would have been minimized and the life of one of them most probably saved had the orders in this regard been complied with.

3. It was evident, also, that the instructions laid down for the prevention of fire in motor boats had not been observed.

4. Commanding officers are to ensure that the instructions contained in the C.O.R., Article 309, Article 335 of the Engineering Manual (1939) and Navy Order 238 of 1943 are strictly observed, and that personnel, whilst engaged in engine room duties in petrol-driven craft, wear overall protective clothing. Failure to do so is to be treated by Commanding Officers as a disciplinary offence.

(603/246/4345.)

(This Order will be reprinted for posting on Notice Boards.)

574.

MOTOR TRANSPORT—PREVENTION OF THEFT.

A number of cases has been reported recently of the theft and unauthorized use of Service motor vehicles which have been left unattended.

2. Action should be taken to advise all concerned that, when a vehicle is left unattended, the ignition is to be locked and the ignition keys removed from the vehicle and retained in the custody of the driver. When a vehicle is likely to be left unattended for a lengthy period, the doors and windows (when applicable) are also to be locked as an extra precaution.

3. All jeeps, which are not provided with ignition locks, are to be fitted with a locking device to ensure against theft. An extension piece of mild steel is to be bolted, spotwelded and riveted to the dashboard. This extension piece is to be drilled to take a padlock, and when the vehicle is left unattended the gear lever is to be placed in reverse and locked to the extension piece with a padlock. Copies of a sketch illustrating the method of locking the vehicles are being forwarded to all concerned.

4. Any vehicles other than jeeps, which are not provided with ignition locks, are also to be fitted with a similar locking device where practicable.

5. A report is to be forwarded to Navy Office when all vehicles concerned have been fitted with locking devices.

(638/202/2456.)

575.

DISTINGUISHING PENDANTS—FRIGATES AND A.M.S. VESSELS (CORVETTES).

The distinguishing pendants allotted to Frigates and A.M.S. Vessels are to be painted on each bow, with the exception of the Senior Officer's Ship.

2. The pendant numbers are to be of the following dimensions:—

4½ feet deep,
3 feet wide,
6-inch block,

numbers to be spaced 2 feet apart.

(476/201/821.)

576.

KIT BAGS, HAMMOCKS, ETC.—LOSSES DURING TRANSPORT—LABELLING AND MARKING.

The following signal despatched to all Shore Establishments in Australia, T.O.O. 230924, November, is included in Navy Orders for the guidance of all concerned:—

“Unaccompanied baggage delivered by Naval Establishments to Military Forwarding Organization for transmission to other Naval Establishments on mainland, in accordance with instructions contained in Navy Order 264 of 1945, will, as from 24th November, be consigned by Military Forwarding Officers direct to main railway centres only. For example, packages for *Cerberus* and *Lonsdale* to Spencer-street Railway Station instead of to Local Military Forwarding Officer as at present.

(2) Consignments to *Huon*, however, will, for shipping reasons, continue to be dealt with by the Military Forwarding Officer, Melbourne.

(3) Packages for destinations other than *Huon* are to be addressed to main railway centres, as indicated above, before delivery to the Military Forwarding Officer.

(4) Convoy Note and copy of Consignment Note will be forwarded by Military Forwarding Officers direct to Naval Establishments concerned, which are to arrange for baggage to be collected immediately after arrival.

(5) Instructions regarding signalled advices to receiving establishments of baggage delivered to Military Forwarding Officers, and subsequent confirmation by mail on Form D.80, *vide* paragraphs 8 and 10 of Navy Order 264 of 1945, are to continue to be observed.

(6) It is noted that at certain centres unaccompanied baggage is, on occasions, still being despatched by Rail Transport Officers, instead of from Naval Establishments through Military Forwarding Officers, as directed in paragraph 6 of Navy Order quoted. Having in view the necessity for proper record and subsequent action in relation to claims to be rendered to Railway Departments in event of loss or damage occurring in transit, despatch of unaccompanied baggage by Rail Transport Officers is to be entirely discontinued.”

(516/201/686.)

577.

SPECIAL CHRISTMAS FARE, 1945.

The following victualling arrangements relating to Christmas Day, which are contained in general signal T.O.O. 290347, November, are promulgated in Navy Orders for the guidance of all concerned:—

- (a) Additional expenditure in general mess ships and establishments will be governed by C.O.R., Article 451, special attention being drawn to paragraph 6 thereof.
- (b) Naval personnel in receipt of Army rations will receive Christmas Fare as provided for Army personnel.
- (c) Approval is given for petty officers and men in all repayment ships to be credited in Form A.S. 462z with one shilling and six pence per head, in addition to the prevailing victualling allowance for the day in the area concerned, for purchase of special foodstuffs.

(668/201/3093.)

578.

GENERAL MESS BALANCES IN H.M.A. SHIPS AND SHORE ESTABLISHMENTS—WAIVURE AS FROM 31st MARCH, 1945.

The following general signal T.O.O. 280601 November is included in Navy Orders for the guidance of all concerned:—

“The general mess balance, whether debit or credit, which existed in each H.M.A. ship or shore establishment on 31st March, 1945, is hereby waived, the necessary adjustment being effected in current victualling accounts on Friday, 30th November, only.”

(530/201/296.)

579.

MEDICAL STAFF—REPATRIATION COMMISSION.

In view of the increasing responsibilities of the Repatriation Commission consequent on demobilization, applications for full-time employment are invited from medical practitioners, particularly those with oversea service, for—

- (a) classified (permanent) appointment;
- (b) temporary appointment;
- (c) limited period appointment for one or more years.

2. Appointment would be to the staff of a Repatriation General Hospital or Sanatorium, but, as a result of the arrangement whereby Repatriation patients will be admitted to separate wards in Army base hospitals, a progressively increasing number of medical officers, as well as nursing and other staff, will be employed in them. Eventually the control of these Army base hospitals will pass to the Repatriation Commission.

3. Special opportunities exist for the appointment of medical officers with experience in treatment of psychiatric disorders or of pulmonary tuberculosis. Quarters for married men are not available, and may not be even for single men.

4. There are also vacancies on the medical staffs of the Repatriation Branch Offices in the capital cities in Queensland, New South Wales and South Australia.

5. The present commencing rate for medical officers is £760 per annum, rising by annual increments of £36 to £904, and then to £952, and these rates are subject to adjustment based on the rise and fall in the cost of living. The maximum rate for Branch Office appointments is £48 higher than the institutional rate. The general conditions of the Commonwealth Public Service apply as to medical examination prior to appointment, hours of duty, sick and recreational leave, long service furlough, retiring age, contribution to superannuation, or, under certain conditions, to the Provident Fund. However, applicants must serve for a probationary period of six months if appointed to the classified staff, before confirmation of appointment is approved. Application should be made, in the first instance, to the Repatriation Commission, 314 Collins-street, Melbourne, C.1, Victoria, stating age, whether married or single, qualifications, civil and war experience, the State in which employment is desired and its nature, e.g., permanent, temporary, or for a fixed term.

6. The Commission also invites applications from specialists and consultants for part-time or visiting appointments, and those interested should give full particulars of their qualifications, experience and the State in which appointment is desired. Of course, if full-time appointment, either permanently, temporarily, or for a period, were desired, this should be stated.

(406/201/483.)

580.

OFFICERS' WORKING DRESS.

With reference to paragraph 2 of Navy Order 442 of 1945, the rates at which supplies of officers' working dress are obtainable from the Commonwealth Government Clothing Factory are to be amended, as follows, viz. :—

Jackets	£1 11s. each
Trousers	£1 12s. 6d. pair.

(434/215/1126.)

RESTRICTED.(FOR OFFICIAL USE ONLY.)

Commonwealth Navy Orders.

Navy Office, Melbourne,
18th December, 1945.

The following Orders, having been approved, are hereby promulgated for information and guidance and necessary action.

By direction of the Naval Board,

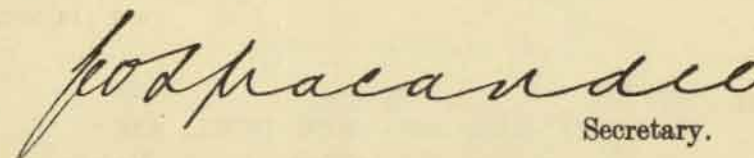
Secretary.

*The Commodore Commanding H.M.A. Squadron,
and Commanding Officers of H.M.A. Ships,
Officers in Charge of H.M.A. Naval
Establishments, and others concerned.*

TABLE OF CONTENTS.

No.	Subject.
581.	Naval Officer-in-Charge, Broome—Termination of Appointment.
582.	H.M.A.S. "Ladava"—Paying off.
583.	H.M.A.S. "Moreton"—Name Ship.
584.	Postal Addresses—New Guinea Area.
585.	Transfer of "Q" Class Destroyers to R.A.N. and Reversion of "N" Class Destroyers to R.N.
586.	Amalgamation of Torpedo and Anti-Submarine Branches.
587.	Ordnance Q.F. 2 pdr. Mark VIII—Adjustment of Cartridge Headspace.
588.	O.Q.F. 40 mm. Bofors Mk. I and I*—Modification to Breech Casing.
589.	Forms S.1404—Return of B.L. and Q.F. Guns—Rendering.
590.	Economy in the Use of Motor Transport.
591.	Signals—Indications of Priority.
592.	Reports of Proceedings.

581.

NAVAL OFFICER-IN-CHARGE, BROOME—TERMINATION OF APPOINTMENT.

The appointment of the Naval Officer-in-Charge, Broome, was terminated on 30th November, 1945.

(409/201/3556.)

582.

H.M.A.S. "LADAVA"—PAYING OFF.

With reference to Confidential Commonwealth Navy Order 108 of 1943, H.M.A.S. *Ladava* was paid off on 30th October, 1945.

(556/201/1900.)

583.

H.M.A.S. "MORETON"—NAME SHIP.

With reference to Navy Order 177 of 1943 the Name Ship H.M.A.S. *Moreton* was paid off on 28th November, 1945.

2. Motor Launch 180 has been commissioned as H.M.A.S. *Moreton*.

(603/246/5662.)

584.

POSTAL ADDRESSES—NEW GUINEA AREA.

The appointment of the Naval Officer-in-Charge, Madang, has been incorporated with that of the Naval Officer-in-Charge, New Guinea.

2. Navy Order 297 of 1945 is to be amended accordingly.

(409/201/3557.)

585.

TRANSFER OF "Q" CLASS DESTROYERS TO R.A.N., AND REVERSION OF "N" CLASS DESTROYERS TO R.N.

Consequent on changes regarding the administration and manning of the under-mentioned "N" and "Q" class destroyers, the provisions of Confidential Commonwealth Navy Order 51 of 1944 ceased to apply to these vessels after the dates indicated:—

H.M.A.S. <i>Quiberon</i>	9th October, 1945
H.M.A.S. <i>Nizam</i>	17th October, 1945
H.M.A.S. <i>Napier</i>	24th October, 1945
H.M.A.S. <i>Norman</i>	28th October, 1945
H.M.A.S. <i>Quickmatch</i>	31st October, 1945
H.M.A.S. <i>Nepal</i>	9th November, 1945

2. All transactions connected with the pay, cash account, victualling accounts, &c., of these ships up to the dates shown will be accounted for in the cash account of H.M.A.S. *Napier* (rendered to Admiralty).

3. H.M.A. Ships *Nizam*, *Napier*, *Norman* and *Nepal* have been re-commissioned as H.M. Ships and are now manned by R.N. personnel.

4. The following "Q" class destroyers have been transferred on loan from Admiralty, and from the dates shown below became a liability of the Australian Commonwealth Government:—

H.M.A.S. <i>Quiberon</i>	10th October, 1945
H.M.A.S. <i>Quadrant</i>	18th October, 1945
H.M.A.S. <i>Quality</i>	25th October, 1945
H.M.A.S. <i>Queenborough</i>	29th October, 1945
H.M.A.S. <i>Quickmatch</i>	1st November, 1945

5. All transactions connected with the pay, cash account, victualling accounts, &c., of the ships shown in paragraph 4 will be accounted for in the cash account of H.M.A.S. *Quality* from the dates shown to 30th November, 1945, and in the cash account of H.M.A.S. *Quickmatch* from 1st December, 1945 onwards.

6. All correspondence and signals dealing with the pay, service certificates, cash accounts or victualling accounts of any of the above ships ("N" class to the dates shown only) are to be forwarded to the Supply Officer, R.A.N. Destroyers, whose office is at present situated at Room No. 630, Bank of New South Wales, No. 7 Wynyard-street, Sydney. Telephone No. B.0539, extensions 176 and 19.

Addresses: For correspondence—Supply Officer,
R.A.N. Destroyers,
c/o Fleet Mail Office,
SYDNEY, N.S.W.

For signals—Supply Officer, R.A.N. Destroyers.

7. Navy Order 265 of 1945 is cancelled.

(401/211/1340.)

586.

AMALGAMATION OF TORPEDO AND ANTI-SUBMARINE BRANCHES.

Pending promulgation of details of the scheme for amalgamation of the Torpedo and Anti-Submarine Branches as notified in A.F.O. 649/45, applications will be received from Officers desiring to volunteer for the new T./A.S. Branch.

2. Officers who have volunteered to specialize in either (T) or (A/S) should indicate whether they volunteer for the new T./A.S. Branch.

(614/201/100.)

587.

ORDNANCE Q.F., 2 PDR., MARK VIII—ADJUSTMENT OF CARTRIDGE HEADSPACE.

The attention of all Ships, Armament Depots and Inspecting Officers is drawn to the necessity of maintaining the correct headspace adjustment of Q.F. 2 pdr., Mark VIII guns, in order to avoid failures due to separation of projectile and cartridge case in the feed box.

2. All guns are to have the headspace adjusted to 0.092" by the following method:—

(a) Insert Gauge D.O.T.M. 2816, with marking applied to the base, into the chamber of the gun, taking care that it is fully home and that the large flats on the gauge are vertical.

- (b) Remove upper gib and gib locking bars.

Assemble the lock and extractor on the connecting rod making sure that the connecting rod nut is screwed hard home. Present the lock to the gauge cautiously and repeat, adding adjusting washers under the connecting rod nut, until there is a rubbing contact between extractor face and the gauge so that the extractors will just not rise freely.

- (c) Whenever adjusting washers are added, the connecting rod nut must always be screwed hard home before testing.
- (d) The correct adjustment is with the minimum number of washers which will transfer marking to the lock face.
- (e) The adjustment of each lock may be different for each gun mechanism.
- (f) When the upper gib is reassembled in the lock and pressed hard down in the unlocked position, the gib must not be proud of the extractor face.

3. Gauges D.O.T.M. 2816 will be issued without demand in the following proportions:—

- 1 to each ship equipped with 2 pdr. Mark VIII guns.
2 to each R.A.N. Armament Depot, Sydney, Fremantle and Darwin.

(408/208/918.)

588.

O.Q.F. 40 MM. BOFORS MKS. I AND I*—MODIFICATION TO BREECH CASING.

The following modification has been approved in the Royal Australian Navy:—

Gun 40 mm. Bofors Mk. I & I*
Part affected Breech casing.
Purpose To permit fitting of bracket for Gyro sight when gun is mounted in a 40 mm. Mk. III P mounting.

Nature of Modification (i) Drill and tap 6 in No. holes $\frac{3}{8}$ " B.S.F. to suit bracket gyro sight (W.72943). (If bracket is not fitted, holes are to be plugged with $\frac{3}{8}$ " B.S.F. Cheese Head screws $\frac{3}{8}$ " long.)
(ii) Drill and tap 1 in No. hole to suit lubricator, 10 mm. diam. by 1 mm. pitch.
(iii) 1 in No. existing lubricator hole to be plugged.

New Parts Required .. Nil.
Drawing In accordance with attached diagram (D.O.T.M. Drawing No. 82532).

By whom to be done .. Naval Armament Depots.
Degree of Urgency .. First opportunity.

(490/212/1389),

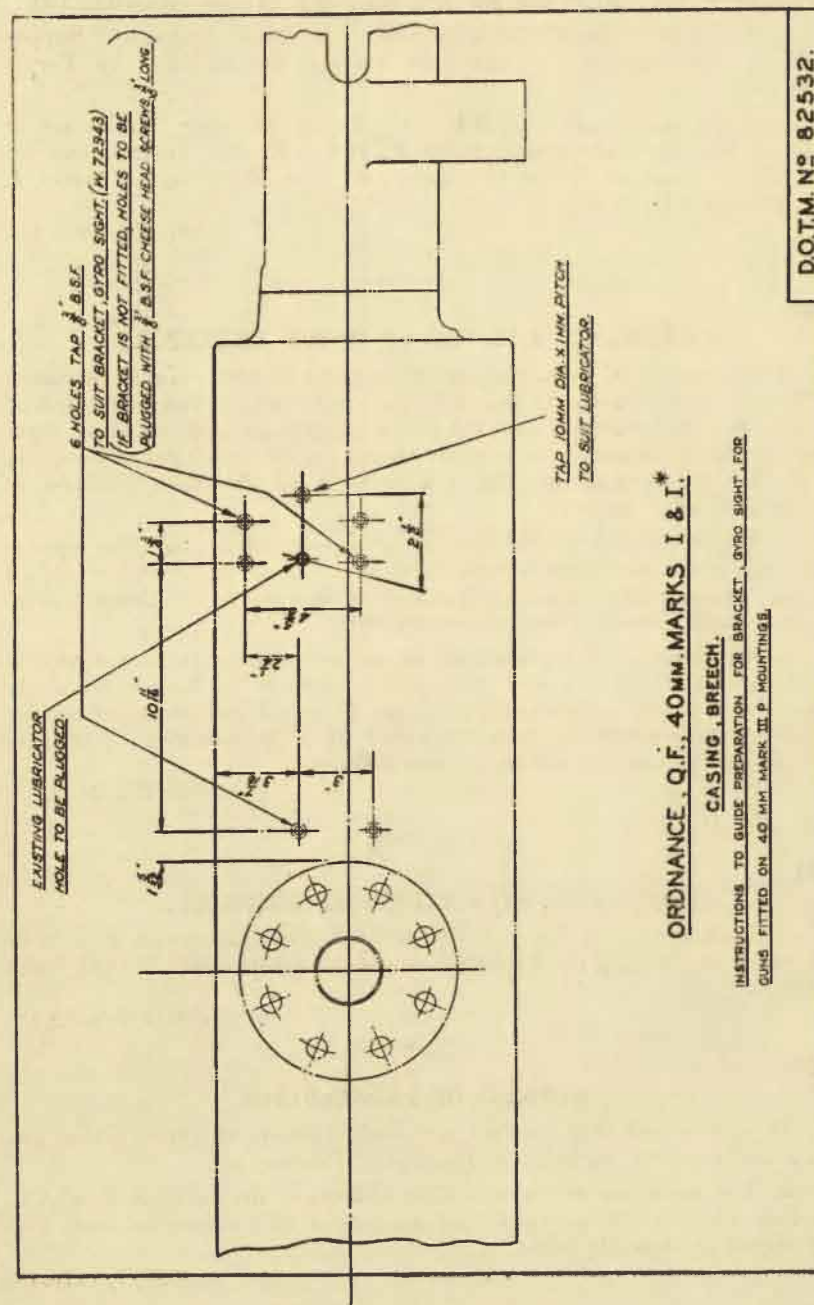

589.

FORMS S.1404—RETURN OF B.L. AND Q.F. GUNS—RENDERING.

It has been reported that requisitions on Naval Armament Supply Officers for inspection of ordnance are not accompanied by Forms S.1404.

2. Attention is called to B.R. 291, Tables Showing Particulars in Regard to Naval Ordnance, Table F, and B.R. 292, Instructions for the Maintenance of Naval Ordnance and Gun Mountings, Chapter I, paragraphs 1 to 6.

(490/201/1925.)

590.

ECONOMY IN THE USE OF MOTOR TRANSPORT.

The attention of Commanding Officers and all other Naval personnel concerned is drawn to the necessity for closer supervision in the use of Naval Motor Transport, and for strict compliance with standing regulations and instructions in relation thereto, with the object of ensuring that the employment of such transport is at all times confined to essential Service matters.

2. Whenever practicable, normal public transport facilities applicable to peace conditions should now be reverted to, Naval transport being utilized only when that course is necessary for Departmental reasons or is more economical in operation.

3. In future, the replacement of motor vehicles or the supply of additional vehicles will only be approved when it has been conclusively established to the satisfaction of the Naval Board that essential Service requirements cannot be reasonably met by a re-allocation of vehicles already authorized for the naval base concerned.

(638/202/2458.)

591.

SIGNALS—INDICATIONS OF PRIORITY.

With reference to Navy Order 503 of 1945, paragraph 2 is to be amended by deleting the hyphen between the letters "OU", "OA" and "OP".

(2037/2/1352.)

592.

REPORTS OF PROCEEDINGS.

It is observed that matters requiring answers or other action are, in some instances, included in Reports of Proceedings.

2. The attention of Commanding Officers is drawn to K.R. & A.I., Article 1132, which provides that matters of this nature be dealt with by signal or separate letter.

(2026/7/1479.)

RESTRICTED.(FOR OFFICIAL USE ONLY.)**Commonwealth Navy Orders.**

Navy Office, Melbourne,
24th December, 1945.

The following Orders, having been approved, are hereby promulgated for information and guidance, and necessary action.

By direction of the Naval Board,

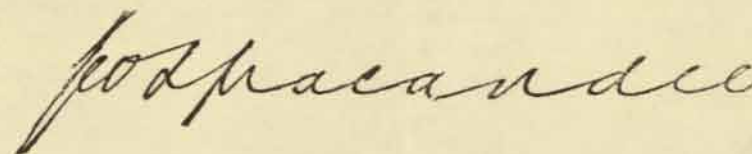

Secretary.

*The Commodore Commanding H.M.A. Squadron,
and Commanding Officers of H.M.A. Ships,
Officers in Charge of H.M.A. Naval
Establishments, and others concerned.*

TABLE OF CONTENTS.

No.	Subject.
593.	H.M.A. Ships—Paying off.
594.	Royal Navy Ships—Paying off.
595.	Seaward Defences—Addresses.
596.	Disposal of Relics, Presentations and Trophies Held in H.M.A. Ships, &c., Paying off.
597.	R.A.N. and R.A.F.R. Long Service and Good Conduct Medals—Clasps.
598.	Books and Forms.
599.	Discharge from the R.A.N. on Account of Physical Unfitness for Service.
600.	Naval Dockyard, Melbourne.—Vacancies.
601.	Corrigendum.

593.

H.M.A. SHIPS—PAYING OFF.

The following H.M.A. Ships were paid off on the dates indicated:—

H.M.A. Ship.	Date of Paying Off.	H.M.A. Ship.	Date of Paying Off.
<i>Anaconda</i> ..	8th December, 1945	<i>Kybra</i> ..	23rd November, 1945
<i>Bermagui</i> ..	23rd November, 1945	<i>Lauriana</i> ..	27th November, 1945
<i>Cape Leeuwin</i> ..	12th December, 1945	<i>Malanda</i> ..	30th November, 1945
<i>Catherine R.</i> ..	29th November, 1945	<i>M.L. 427</i> ..	1st December, 1945
<i>Colac</i> ..	27th November, 1945	<i>Paterson</i> ..	26th November, 1945
<i>Cootamundra</i> ..	26th November, 1945	<i>San Michele</i> ..	10th December, 1945
<i>Gloria</i> ..	27th November, 1945	<i>Sea Snake</i> ..	27th November, 1945
<i>Gunbar</i> ..	3rd December, 1945	<i>Southern Cross</i> ..	22nd November, 1945
<i>Kara Kara</i> ..	8th December, 1945	<i>Toomeree</i> ..	4th December, 1945
<i>Kuramia</i> ..	3rd December, 1945	<i>Vendetta</i> ..	27th November, 1945
<i>Kwato</i> ..	10th December, 1945	<i>Wagga</i> ..	28th November, 1945

(603/247/11961.)

1961-TOP
NO. 15 2160

594.

ROYAL NAVY SHIPS—PAYING OFF.

The following Royal Navy Ships were paid off on the dates indicated:—

H.M.S. <i>Nabthorpe</i>	15th November, 1945
H.M.S. <i>Nabbington</i>	15th November, 1945
H.M.S. <i>Beaconsfield</i>	30th November, 1945

(1804/4/63.)

595.

SEAWARD DEFENCES—ADDRESSES.

As the need for security addresses no longer exists, correspondence for R.A.N. Stations may now be addressed direct.

2. Confidential Commonwealth Navy Order 63 of 1945, is cancelled.

3. All correspondence, &c., for the R.A.N. Mine Depot, Byford, W.A., should now be addressed as follows:—

Deputy Armament Supply Officer,
R.A.N. Mine Depot,
Byford, W.A.

(Short title, D.A.S.O. Byford.)

(443/201/1546.)

596.

DISPOSAL OF RELICS, PRESENTATIONS, AND TROPHIES HELD IN H.M.A. SHIPS, ETC., PAYING OFF.

With reference to Navy Order 413 of 1945, the following procedure is to be observed in regard to the disposal of relics, presentations, and trophies in vessels being paid off and in Shore Establishments and Services being closed down:—

- (a) Relics, presentations, and trophies are to be classed as valuable items and dealt with as indicated in paragraph 4 of the above-mentioned Navy Order, the provisions of which generally are applicable as regards muster and return to Store of all relics, presentations, and trophies on Permanent Loan.
- (b) Separate Return Vouchers (Forms A.S. 331) are to be raised for presentations, &c. In the case of any items the donor of which stipulated a condition at the time of presentation, e.g., to be returned on cessation of hostilities, &c., advice by memorandum of such condition is to be forwarded by the Commanding Officer of the ship, &c., to the Naval Officer-in-Charge concerned, the serial number of the relevant Form A.S. 331 being quoted therein.
- (c) On receipt at a Naval Store Depot or Base Naval Store, the presentations, &c., from each ship should be stowed separately, and every possible precaution is to be taken to ensure safe custody.
- (d) Particulars of all presentations, &c., received from each individual ship at a Naval Store Depot or Base Naval Store should be forwarded to Navy Office, including details of any conditions attached to such items, *vide* (b) above.

2. In the case of trophies and presentations in the nature of table decorations, &c., which fall more readily under the category of mess traps or victualling items than ordinary naval stores, the Naval Officer-in-Charge at the port concerned should determine in the light of storage and other facilities available whether such items should be stored at the naval or victualling storehouses. Where storage at a victualling storehouse is desirable, arrangements should be made for the items concerned to be transferred direct from the ship to the appropriate Victualling Store Officer or Supply Officer.

3. The attention of all concerned is drawn to Appendix Reference No. 3 to the R.A.N. Supplement to the Naval Storekeeping Manual B.R.4, particularly in regard to inspection as to condition before a receipt is given and care in handling, &c., to safeguard articles from damage, &c.

(635/201/1722.)

597.

**R.A.N. AND R.A.F.R. LONG SERVICE AND GOOD CONDUCT
MEDALS—CLASPS.**

It has been decided to issue a clasp to the R.A.N. and R.A.F.R. Long Service and Good Conduct Medals in the case of ratings holding the Medals, who have completed a further 15 years' service under the conditions governing the original award (*vide* K.R. and A.I., Article 534, clause 2, and R.A.F.R. Regulations, Articles 103A and 103B). The award of a clasp will not entitle the recipient to any additional gratuity.

2. It is to be clearly understood that a clasp to a R.A.F.R. Medal will only be awarded to applicants who have served or are serving as mobilised reservists or on engagements in respect of which approval has been given for the service to reckon for reserve benefits.

3. Rosettes to be worn on the ribbon of the Medal when worn without the Medal will be issued at the same time as the clasp.

4. This Order has retrospective effect, and applications for the award of clasps may be made in manuscript or on Form A.S. 218, endorsed "CLASP ONLY" and should be forwarded to the Secretary, Naval Board, Melbourne, by the Commanding Officer of the ships and establishments in which the men are serving, accompanied by a True Copy of Service Certificate.

5. Men no longer serving should apply direct.

(448/201/2075.)

(This Order will be printed for posting on Notice Boards.)

598.

BOOKS AND FORMS.

First supplies of the undermentioned publications have been distributed. Additional supplies of B.R.'s 1066, 1224A, and 1224E are being obtained to complete distribution:—

B.R. 358 and Form D. 254D	Establishment of Naval Stores for Executive Purposes and List of Particulars—Lists of Errata No. 9	(A.F.O. 2805/45) (571/202/1503.)
B.R. 359 and Form D. 128D	Establishment of Naval Stores for Electrical and Torpedo Purposes and List of Particulars—List of Errata No. 14	(A.F.O. 1349/45) (571/202/2229.)
B.R. 386	.. Establishment of Naval Stores for Photographic Purposes in H.M. Ships	(A.F.O. 3968/45) (571/202/2235.)
B.R. 431/43	.. A Naval Prayer Book ..	(A.F.O. 1981/43) (571/202/2108.)

B.R. 640 (1)/45	.. General Combined Operations Pamphlet No. 3A which was issued as C.B. 03132, has been de-classified to the "Restricted" Series as B.R. 640 (3A)	(A.F.O. 4777/45) (A.F.O. 2956/45)
B.R. 640 (3A)		
	<i>Combined Operations Pamphlets.</i>	
B.R. 640 (6c)/45	.. Naval Communications in Combined Operations	(A.F.O. 3411/45)
B.R. 640 (7B)/45	.. S.P. Artillery in an Assault Landing	(A.F.O. 3411/45)
B.R. 640 (24)/45	.. Cliff Assaults	(A.F.O. 3411/45)
B.R. 640 (26)/45	.. Commandos in the Field ..	(A.F.O. 3411/45) (571/201/4830.)
B.R. 943/45	.. Turret Gun Drill for 6-in. B.L. Guns Mark XXIII. on Twin Mark XXI. Mounting	(A.F.O. 3807/45) (571/202/2223.)
B.R. 979/45	.. Handbook for Apparatus A.D. Type D. (P.A.C.) and Rocket Illuminating 9 lb. (Snowflake)	(A.F.O. 2807/45) (571/202/2218.)
B.R. 992 (1)	.. Addendum No. 1 to B.R. 992—Handbook for the Ordnance Q.F. 6-pdr. 10 cwt. Mark I., on Mtg. 6-pdr. Mark I., Land Service, 1939	(A.F.O. 3217/44) (571/202/1881.)
B.R. 1066	.. Advancement Regulations .. <i>N.B.</i> Attention is directed to paragraph 5 of A.F.O. 479/45 relative to amendment to be made to B.R. 1066 on receipt	(A.F.O. 479/45) (571/202/2109.)
B.R. 1224A/45	.. Handbook for the Mark XXXVII. Director System, Vol. I., General	(A.F.O. 1351/45)
B.R. 1224E/45	.. Handbook for the Mark XXXVII. Director System, Vol. V., the Mark VI. Stable Element	(A.F.O. 2524/45) (571/202/2152.)
B.R. 1230 (2)/44	.. Regulations for Maintenance of Supersedes O.U. 6341 (2) 21-in. L.C. Marks II. and II*. Torpedo Tubes (Cordite Impulse) in M.T.B's.	(A.F.O. 2955/45) (571/202/2231.)
B.R. 1240/45	.. Fire Control Drill for "A" to "I" Class Escort Destroyers, Frigates, and Corvettes (Castle Class)	(A.F.O. 3084/45) (571/202/2215.)
B.R. 1242/45	.. How to Use the Film Strip in Your Training Schedule	(A.F.O. 1231/45) (571/202/2150.)

- B.R. 1249/45 .. Preliminary Pamphlet for 40 mm. Bofors Twin R.P. 50 Mark V. Mtg. (A.F.O. 3085/45) (571/202/2214.)
- O.U. 6092A .. Proportion Book of Naval Armament Stores—Part 1—Errata Nos. 16–18 (A.F.O's. 6226/44 and 2804/45) (571/203/2569.)
- O.U. 6353 .. British Merchant Vessels lost from Outbreak of War—January and February, 1945, A.M. No. 36 (A.F.O. 2804/45)
- O.U. 6353A/41 .. Foreign Merchant Vessels lost January and February, 1945, A.M. No. 35 (A.F.O. 2804/45) (571/203/2460.)
- Errata No. 4 .. Establishment of Naval Stores for 72-ft. Motor Launches (612/226/1232.)

599.

DISCHARGE FROM THE R.A.N. ON ACCOUNT OF PHYSICAL UNFITNESS FOR SERVICE.

The conditions relating to the discharge of members of the R.A.N. on account of physical unfitness have been reviewed and are shown hereunder. This procedure is apart from that applicable to demobilisation through the organisation set up for that purpose and in regard to which instructions have been issued separately.

2. In regard to date of discharge from the R.A.N.—

(a) A member on full time duty who, following examination by a Medical Board of Survey, is, in the opinion of the Naval Board, unfit for further service will, subject to the provisions of sub-paragraphs (b), (c), (d), (g), and (h) hereof, be discharged from the Service—

(i) When he is no longer, at the time, in need of further active medical treatment as an in-patient and is capable of—

- (α) resuming his pre-enlistment occupation ; or
- (β) following some other occupation ; or
- (γ) being trained for some skilled occupation ; or

(ii) when the period of his treatment in a Service hospital or convalescent depot in Australia has totalled six months, whichever is the earlier.

(b) Where a medical board considers that the member's recovery or rehabilitation into civil life may be furthered by retention in a Service hospital or convalescent depot for a further period or periods not exceeding a total extension of six months, recommendation may be made to the Naval Board that the member's discharge be postponed accordingly.

(c) In special cases, such as those with severe amputation, or requiring special bone grafting, facio-maxillary or plastic surgery treatment, the extension referred to in sub-paragraph (b) may be increased by the Naval Board to twelve months if such extension will further the member's recovery or rehabilitation into civil life.

(d) A member suffering from an incurable malignant disease whose expectation of life is a matter of months, may, subject to the Naval Board's approval, be retained in a Service hospital and his discharge postponed accordingly for as long as he is in need of active medical treatment up to twelve months after the expiration of the period referred to in sub-paragraph (a) (ii), provided that a further extension or extensions may be granted if necessary with the special approval of the Naval Board.

(e) In cases of pulmonary tuberculosis, whether attributable to war service or not, the time of discharge will be governed by sub-paragraphs (a) and (b) above, and for the purposes of these sub-paragraphs, treatment in a repatriation or other civil institution will be deemed to be treatment in a service hospital or convalescent depot in Australia.

(f) In cases of incurable or unmanageable mental disease, the provisions of sub-paragraph (e) will apply.

(g) Subject to sub-paragraphs (d), (e), and (f) above, a member who is unfit for further service as a result of a pre-enlistment disability not aggravated by service or of chronic disease or constitutional inadequacy not related to service is—

(i) If no longer in need of immediate active medical treatment and unsuitable for medical rehabilitation to be discharged with Naval Board approval to the shore as soon as practicable, notwithstanding that the period referred to in sub-paragraph (a) (ii) has not elapsed.

(ii) Whilst in need of immediate active medical treatment or suitable for medical rehabilitation, to be retained, with Naval Board approval, until the period referred to in sub-paragraph (a) (ii) has elapsed, and then discharged, notwithstanding the provision of sub-paragraph (b) hereof.

(h) In amputation cases, a member may be retained in the R.A.N. until an artificial limb has been supplied and he has been instructed in its use, provided that the maximum period of his retention shall not exceed that provided for under sub-paragraph (b) or in cases to which sub-paragraph (c) applies, the period provided for under that sub-paragraph. (See Navy Order 63 of 1942 re supply of artificial limbs.)

3. Arrangements are to be made for the attendance of a medical officer of the Repatriation Commission at invaliding surveys and the reason for recommending discharge or further treatment should be clearly stated on Form A.M. 252z. Such surveys should be held at convenient periods, but not less frequently than once a month if cases are awaiting decision.

With reference to C.O.R., Articles 557 (1) and 558 (6), as amended by Navy Order 280 of 1942, prescribing that survey of cases should be held after a period of 151 days' continuous treatment, where a reasonable probability of ultimate fitness for return to duty exists, it will not be necessary for the Repatriation Commission to be represented at such surveys.

4. The opinion of the medical officer of the Repatriation Department, as to the eligibility of the member for war pension, should be noted at the foot of page 4 of Form A.M. 252z.

5. Discharge from the R.A.N. will take place as a rule, as soon as practicable after the date on which all papers relating to the case are forwarded to the Repatriation Commission from Navy Office. In the interim, necessary action in connection with rehabilitation to civil life should be taken. If the case is not one for reference to the Repatriation Commission, discharge will take place as soon as possible after the date of survey, on completion of rehabilitation procedure, subject to recall in the event of Naval Board approval to discharge not being given in any special case. Advice regarding actual date of discharge is to be forwarded to Navy Office in all cases, as soon as it is known. Payment in lieu of re-establishment leave is to be made on discharge.

6. For the information of medical officers, the following are the requirements necessary to establish a diagnosis of pulmonary tuberculosis:—

- (a) The tubercle bacillus to be found on at least two occasions in sputum which has been expectorated in the presence of a medical officer or nursing sister or responsible sick berth rating, or in the gastric contents or pleural fluid; or
- (b) The diagnosis to be agreed upon by a medical representative of the Repatriation Commission, who should be afforded the opportunity of seeing the case, attending the Board or examining the clinical records before the Board is held.

7. Provision of medical treatment and rehabilitation—

(a) Prior to discharge from the R.A.N., medical treatment and rehabilitation will be provided by the Navy Department, except in the case of patients suffering from pulmonary tuberculosis or incurable or unmanageable mental disease, who should be transferred to a Repatriation or other civil institution, as appropriate, as soon as practicable.

(b) After discharge from the R.A.N., treatment will be provided as follows:—

(i) Members entitled to Repatriation pensions—

Normally by the Repatriation Commission, except that, in order to meet special circumstances, the provision of treatment may be a matter of arrangement between this Department and the Repatriation Commission.

(ii) Members not entitled to Repatriation pensions—

By civil medical institutions, provided that, pending such accommodation being available, treatment may be continued in a Service hospital.

8. Before any member who is an inmate of a Service hospital and who does not become a Repatriation responsibility is discharged, arrangements are to be made for the continuation of any necessary treatment in a civil hospital as an in-patient or an out-patient, according to the requirements of the case. The cost of such treatment is not a liability of the Commonwealth beyond date of discharge from the Navy.

9. The following action is to be taken in respect of members surveyed for invaliding:—

(a) Non-Repatriation Cases—

(i) When an unqualified recommendation of discharge "P.U.N.S." or "B.N.P.S." is made by the Medical Board of Survey and where the member concerned no longer needs active medical treatment and can be discharged without detriment to health, approval is given for such member to be discharged to home port, action then being taken in accordance with paragraph 5 above,

(ii) When the recommendation of the Board of Survey is qualified, i.e., in cases where a clear recommendation of discharge "P.U.N.S." or "B.N.P.S." is not given, or when any doubt as to ultimate disposal exists, the question of whether discharge is to take place or not will be decided by Navy Office, and a signal made accordingly. Pending receipt of this signal, members coming within this category are to be retained.

The ship or establishment in which the member is surveyed is to bear the ledger account for the period of travelling involved, making all necessary adjustments, and finally close the account and render Form A.S. 1031z, &c., to the Director of Navy Accounts. Advice of the disposal of the member concerned is to be forwarded immediately to Navy Office, the Commodore Superintendent of Training, Flinders Naval Depot, and the Naval Officer-in-Charge of the home port.

(b) Repatriation Cases—

A member who the Board of Survey (including a Repatriation Medical Officer) considers should be referred to the Repatriation Department, should be sent to home port, if fit to travel, to await Naval Board decision regarding his or her discharge, usual rehabilitation procedure being followed in the meantime.

10. A member with no disability or whose degree of civil disability is negligible should be dealt with in accordance with the procedure set forth in sub-paragraph (a) of paragraph 9 above, even though he is recommended for reference to Repatriation Department in respect of treatment.

11. To facilitate action in Navy Office, a signal is to be sent after survey for invaliding stating the names and official numbers of members surveyed who have been considered Repatriation cases and who have claims for pension in respect of a degree of civil disability.

12. Navy Order 116 of 1945 is hereby cancelled.

(527/211/2117.)

600.

NAVAL DOCKYARD, MELBOURNE—VACANCIES.

Applications are invited from persons desirous of temporary appointment to the undermentioned civil positions at a Naval Dockyard in Melbourne.

2. Applications, stating age, experience, educational qualifications, present employment and enclosing copies of references, should be addressed to the Secretary, Department of the Navy, Melbourne, envelopes being endorsed "Naval Dockyard Vacancies", and should be forwarded at once.

Mechanical Engineer.—A sound theoretical and practical training in Mechanical Engineering with Marine experience is necessary; and the applicant should be capable of organizing and controlling the work of the Mechanical Engineering Branch of a Shipyard engaged on shipbuilding and ship repair work. Standard salary range per annum—minimum £648, maximum £720, subject to cost of living adjustment, at present £40 per annum additional. Commencing salary will be determined according to qualifications and experience.

Engineering Foreman.—Experience in Marine Engineering and previous experience in a supervisory capacity are necessary and the applicant should be capable of taking immediate charge of work connected with the general mechanical engineering branch in a Shipyard, including the installation of machinery in ships, ship repair work, &c. Standard salary range per annum—minimum £492, maximum £504 (subject to cost of living adjustment at present £40 per annum additional) plus wartime allowance £36 per annum. Commencing salary of the successful applicant will be determined according to qualifications and experience.

Shipwright Foreman.—Applicants should have had previous experience in a supervisory capacity and should be capable of taking charge of the general shipwrights' work in connection with the construction, repair, and docking of ships. Previous experience in Loft work and docking of ships is necessary. Standard salary range per annum—minimum £492, maximum £504 (subject to cost of living adjustment at present £40 per annum additional) plus £36 per annum wartime allowance. Commencing salary will be determined according to qualifications and experience.

3. Preference will be given to persons with the necessary qualifications in accordance with the provisions of the Re-establishment and Employment Act (No. 11 of 1945).

601.

CORRIGENDUM.

With reference to Navy Order 525 of 1945—War Gratuity to Members of the Naval Forces—paragraph 3 is to be amended by deleting the word "accepted" (twice occurring) and inserting in lieu the word "excepted".

RESTRICTED.

(FOR OFFICIAL USE ONLY.)

Commonwealth Navy Order.

Navy Office, Melbourne,
24th December, 1945.

The following Order, having been approved, is hereby promulgated for information and guidance, and necessary action.

By direction of the Naval Board,

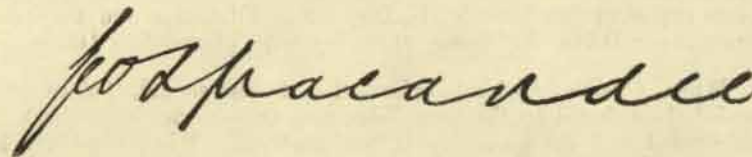

Secretary.

*The Commodore Commanding H.M.A. Squadron,
and Commanding Officers of H.M.A. Ships,
Officers in Charge of H.M.A. Naval
Establishments, and others concerned.*

TABLE OF CONTENTS.

No.	Subject.
602.	R.A.N. Education Service—Reconstruction Training Scheme.

C.12178/45.

602.

R.A.N. EDUCATION SERVICE : RECONSTRUCTION TRAINING SCHEME.

Under the Reconstruction Training Scheme, instruction by correspondence in a wide range of subjects is now available through Universities, Technical Colleges, State Education Authorities, and some other institutions. The subjects at present available are listed in an Appendix to this Order and amendments to this Appendix will be promulgated as new courses are added.

2. Education Officers have been appointed to the principal bases and to cruisers and should be consulted in regard to any difficulties and enquiries arising in connection with the Reconstruction Training Scheme and also in regard to other facilities available through the R.A.N. Education Service.

3. In ships and establishments in which an Education Officer is not borne, the Commanding Officer is to detail an Acting Education Officer who is to accept applications for correspondence courses and carry out liaison duties with the Base Education Officers.

4. *Procedure of Enrolment.*—All applicants for instruction must complete a General Information Form in duplicate and forward both original and duplicate copies of this form to the Director of Education and Vocational Training, Navy Office, Melbourne, through their Commanding Officer.

5. When possible, General Information Forms should, before being forwarded, be referred to the Base Education Officer who is to check the course desired and the eligibility of the applicant. When eligibility has been checked, an Enrolment Form should be completed and forwarded together with the General Information Form.

6. Enrolment Forms together with the Authority to Debit Ledger Account with Fee Deposit are to be completed in duplicate, the Education Officer verifying the fact that the correct name of the subject or subjects as shown in the Appendix to this Order is inserted in the space provided, the correct stage indicated, and the correct figure inserted in the space for amount to be charged in Ship's Ledger. Both copies of the form are to be signed and approved as indicated, the duplicate copy being retained in the ship or establishment for future reference and the original forwarded to the Director of Education and Vocational Training, Navy Office, Melbourne.

7. The amount shown in the Authority to Debit Ledger Account with Fee Deposit is to be estimated on the pro rata basis of 15s. for each individual subject. Applications for more than two subjects will not be accepted. Henceforward the only method of payment of fee deposit is through the Ledger Account, and cash remittances should not be forwarded.

8. When an applicant is uncertain as to what course to take up, or when he desires to do a course that is not listed in the Appendix to this Order, the General Information Form only is to be completed and an Enrolment Form is not to be forwarded until advice of approval of enrolment has been received from the Director of Education and Vocational Training.

9. In the main, one subject is sufficient to keep a Service student fully occupied, and unless there are definite reasons to the contrary, his interests will be best served by his being enrolled for one subject only. Candidates for university and public examinations may be enrolled for two subjects. In the case of the Sydney Technical College, it is desirable for some subjects to be studied concurrently. Subjects so affected are bracketed together. Although, in the main, the subjects listed hereunder are available to members of the Royal Australian Navy from all States, members are advised to enrol through their home State when possible.

10. *Procedure for debiting Pay Account.*—As soon as a member has been enrolled, a Form of Advice will be sent to his Commanding Officer. On receipt of this advice, the amount involved is to be charged against the pay account of the member in accordance with the Authority given in the Order, and the Director of Navy Accounts furnished, as early as possible, with a reference to recovery. The Fee Deposits will then be paid from Navy Office direct to the School concerned. Where the accounts of the Ship in which the member is borne and to which advice of enrolment is sent are kept elsewhere, the advice should be forwarded immediately to the Accountant Officer concerned for action.

11. On the satisfactory completion of each subject, the fee deposit paid will be refunded to the member through his ledger account on advice from Navy Office. In the event of his desiring to enrol for a further subject or subjects, the same procedure should be followed as for an initial enrolment.

12. This Order supersedes Navy Order 524 of 1944, which is hereby cancelled.

13. *Supply of Handbooks, Forms, Equipment, and Text Books.*—A "Handbook for Education Officers" giving details of the courses available through the Sydney Technical College and Melbourne Technical College has been distributed to all ships. Other courses have been notified in circulars issued by the Director of Education and Vocational Training. Supplies of General Information Forms and copies of the above Handbook can be obtained on request either from the Base Education Officer or from the Director of Education and Vocational Training at Navy Office.

14. Requests for text books should be made on an Order Form as laid down in Navy Order 287 of 1944. A text book order (*vide* Navy Order 287 of 1944) should be forwarded together with the Enrolment Form by members who wish to do Leaving Certificate and Intermediate subjects. In the case of Technical College subjects, when text books are required the approximate price is shown in the Handbook, and in respect of these subjects a text book order should be forwarded. Personnel may arrange for the purchase of books other than text books through the Services Book Supply Depot, Bent-street, Sydney, but it must be clearly understood that the provisions of Navy Order 287 of 1944 do not apply in this case and personnel will be required to make their own arrangements for forwarding the money.

15. Enquiries about other facilities that are available through the R.A.N. Education Service such as box libraries, maps, gramophone records, documentary films and sets of tools for pre-vocational training centres, should be made either through the Base Education Officer, or direct to the Director of Educational and Vocational Training.

16. *Class Instruction.*—Where a candidate enrolls at a University, Technical College, or other approved institution and attends classes in subjects which are covered by correspondence courses, provision has been made by the Department of Post-War Reconstruction for a refund of fees paid, up to a maximum of £5 10s. per year. Applicants desiring to enrol for class instruction should obtain the approval of their Commanding Officer and arrange their own enrolment in the same way as does a civilian. After enrolment, a General Information Form should be completed, endorsed "Enrolment for Class Tuition Effected," and forwarded to the Director of Education and Vocational Training. On the completion of the course of instruction, application for a refund of fees should be made through the Commanding Officer to the Director of Education and Vocational Training, who will, after investigating the eligibility of the applicant, take any necessary steps to have this refund effected.

17. *Matriculation.*—The various universities of the Commonwealth have agreed to give special consideration to Service personnel who apply for matriculation. Instead of being required to pass in all the prescribed subjects at one sitting, a member of the Services is allowed to present himself for examination in one or more subjects at a time. Subjects passed at a previous Matriculation or Leaving Certificate examination may, under some circumstances, be taken into consideration.

18. *Examinations.*—Arrangements have been made for the supervision of university and other examinations under Service conditions. Personnel who are doing correspondence courses and who are eligible for examination will be notified and will be required to lodge an application with the Director of Education and Vocational Training not less than two months before the date of the proposed examination.

19. Examination papers will be forwarded through the Director of Education and Vocational Training to the Commanding Officer of the member with all necessary instructions. The completed examination papers will be properly sealed and returned in a confidential package to the Director of Education and Vocational Training at Navy Office.

20. When Service conditions do not permit a member to sit for examination at the exact time and date prescribed, he may sit at the first convenient opportunity within fourteen days of the prescribed date, provided his worked papers are accompanied by an adequate explanation on the part of his Commanding Officer, and a statutory declaration on his own part that he had no knowledge of the content of the papers at the time of his entry into the examination room.

21. As far as the requirements of the Service permit, Commanding Officers are to make provision for the proper conduct and supervision of examinations. It may sometimes be found convenient to land candidates who are serving in small ships so that suitable arrangements for the supervision of their examination may be made by the Base Education Officer.

22. A member doing any subject under the R.A.N. Education Scheme is entitled to complete that subject when demobilized. It is emphasized however that, if that subject forms part of a course, there is no guarantee that he will be able to obtain financial assistance to study further subjects of that course after discharge. The R.A.N. Education Service has no authority to say what course (if any) a member may do when demobilized. This is decided by the Regional Committee of the Central Reconstruction Training Committee when a demobilized member makes his application.

APPENDIX.

SUBJECTS AVAILABLE.

SECTION I.—SUBJECTS AVAILABLE THROUGH THE CORRESPONDENCE TEACHING DIVISIONS OF THE VARIOUS STATE EDUCATION DEPARTMENTS.

Name of Subject.	Classification.	State in which Available.
Primary (at any required standard)—		
English	Basic ..	Tas.
Arithmetic		
Handwriting		
English	Basic ..	Qld.
Arithmetic		
History		
Geography	Basic ..	S.A.
Primary Arithmetic		
Primary English		

These are composite courses, the subjects being taken concurrently as one unit.

A satisfactory education up to the conclusion of the Primary Stage is a pre-requisite for enrolment in the following subjects. In applying for Western Australian and Queensland courses, the word "Junior" should be used instead of "Intermediate". It will be assumed that the applicant desires to begin study at the first year stage unless otherwise stated. Text-books will be required for the courses in Intermediate and Leaving Certificate subjects.

Name of Subject.	State in which Available.
Intermediate—	
Agricultural Science	Vic. (1st and 2nd year only).
Algebra	Qld., W.A., Vic. (1st and 2nd year only).
Arithmetic (see also "Mathematics")	Vic., Qld., W.A., S.A.
Art	N.S.W. (S.A.—see courses in Section II.).
Bookkeeping and Business Principles	N.S.W.
Bookkeeping and Business Methods	Qld.
Commercial Principles	Vic.
Drawing	Vic.
Drawing "A" (Art)	W.A.
English	N.S.W., Qld., S.A., W.A., Vic. (not 3rd year).
English Expression	Vic. (3rd year only).
English Literature	Vic. (3rd year only).
French	N.S.W., Vic., Qld., S.A.
General Science	W.A.
Geography	N.S.W., Vic., Qld., S.A., W.A.

AMENDMENTS.

APPENDIX—continued.

Name of Subject.	State in which Available.
Intermediate—	
Geometry	Qld., W.A., Vic. (1st and 2nd years only).
German	Vic.
History	N.S.W., Vic., Qld., W.A., S.A.
Hygiene and Physiology	W.A.
Latin	N.S.W., Vic., Qld., S.A.
Mathematics I.	N.S.W., S.A.
Mathematics II.	N.S.W., S.A.
Mathematics (General)	N.S.W.
Mathematics A	Vic. (3rd year only), *W.A.
Mathematics B	Vic. (3rd year only), *W.A.
Shorthand	Qld.
Trigonometry	W.A.

Remarks.—See also Sydney Technical College Preparatory Courses Stage I, which are equivalent to N.S.W. third year standard.

* Mathematics A—Arithmetic and Algebra (or Algebra and Trigonometry) are taken singly or together, the fee deposit is 15s.

In the main, a pass at Intermediate Standard is a pre-requisite for enrolment in the following subjects. In applying for Queensland courses the word "Senior" should be used instead of "Leaving Certificate".

Name of Subject.	State in which Available.
Leaving Certificate—	
Agricultural Science	Vic.
Arithmetic (see also "Mathematics")	S.A.
Drawing (Drawing A—W.A.)	Vic. (S.A.—see courses in Section II.).
Economics	Vic.
English	N.S.W., Qld., S.A., W.A., Vic.
French	N.S.W., Vic., Qld., S.A.
Geography	Vic., Qld., S.A., W.A.
German	Vic.
History	Vic., Qld., S.A., W.A.
Industrial History and Economics	W.A.
Latin	Vic., Qld., S.A., W.A. (Stages I. and II.).
Mathematics	N.S.W.
Mathematics I.	Vic., Qld., S.A.
Mathematics II.	Vic., Qld., S.A.
Mathematics A	W.A.
Mathematics B	W.A.
Mathematics, Applied	W.A.
Mechanics	N.S.W.
Physics	W.A.

AMENDMENTS.

APPENDIX—continued.

Remarks.—(a) N.S.W. subjects—English, French, Mathematics, and Mechanics are accepted for Matriculation purposes but do not necessarily conform to text book requirements for the N.S.W. Leaving Certificate.

(b) After March, 1945, Victorian Leaving Certificate courses will not be accepted for matriculation purposes and courses at a more advanced standard will require to be written (see below).

Matriculation (Victoria)—

Economics	French	Pure Mathematics
English Expression	Geography	
English Literature	Modern History	

SECTION II.—SUBJECTS AVAILABLE THROUGH THE CORRESPONDENCE TEACHING DIVISIONS OF THE VARIOUS TECHNICAL COLLEGES.

Literary Courses.

Name of Subject.	Classification.	State in which Available.
English Preliminary	Basic ..	Vic., S.A., W.A., Qld., Tas.
*Freelance Journalism	P. ..	Vic., S.A., W.A., Qld., Tas.
*Short Story Writing	P. ..	Vic.
Writing for Radio	P. ..	S.A.

* (N.B.—Before being enrolled for these subjects, an applicant must submit a sample of work or complete "English Preliminary".)

Preparatory Courses.—These courses are designed for students with a good primary education who desire to bring their educational qualifications up to the required entrance standard for Technical College certificate and diploma courses. They are also recommended for members wishing to improve their general education without sitting for examinations. Subjects shown in brackets may be taken together.

Name of Subject.	State in which Available.
Stage I., English	} N.S.W.
Stage I., Mathematics	
Stage II., English	
Stage II., French	
Stage II., Mathematics	
Stage II., Mechanics	
Stage III., English	}
Stage III., French	
Stage III., Mathematics	
Stage III., Mechanics	

(N.B.—Subjects in Stage III. are accepted as qualifying for matriculation for the University of Sydney.)

AMENDMENTS.

APPENDIX—continued.

The following are Melbourne Technical College type Preparatory Courses. Lower Standard courses take students to the Junior Technical Certificate level; Higher Standard courses are equivalent, but should be taken by those who intend to proceed further with their studies (vide Education Officers' Handbook, Section 2, Page 45).

Name of Subject.	Classification.	State in which Available.
Lower Standard—		
Arithmetic Basic ..	Vic., S.A., W.A., Qld., Tas.
Mensuration P. ..	Vic., S.A., W.A., Qld., Tas.
Higher Standard—		
Arithmetic Basic ..	Vic., S.A., W.A., Qld., Tas.
Mensuration	Vic.
Intermediate—		
Algebra (Technical) P. ..	Vic.
Geometry and Trigonometry (Technical) P. ..	Vic.
Physics	Vic., W.A.

(N.B.—Subjects in the last group prepare students for courses at the Technical Grade I. level. They do not cover the syllabus for the Intermediate Certificate. For Grade I. Mathematics see "Contributory Courses").

Entrance Examination Courses.

Name of Subject.	Classification.	State in which Available.
Nurses' Entrance P. ..	N.S.W., Vic.
Police Entrance P. ..	N.S.W.
Telephonists and Telegraph Messengers	P. ..	N.S.W.

The following occupational courses are grouped under main headings, which are arranged alphabetically. It should be noted carefully that these courses differ in their availability and a column has been provided to show, in the case of each course, what classification it falls into from this point of view. Classification adopted is as follows:—

- Courses open to all persons with a reasonable standard of primary education. These are marked in the following list with the word "Basic".
- Courses open to all persons but which presuppose either that the student has completed some previous course under the Services Education Scheme or has reached a necessary standard of education as laid down in the R.A.N. Education Officers' Handbook. These are marked in the following list with the letter "P".
- Courses in the case of which an applicant must submit a sample of work so that a starting point can be determined. These are marked in the following list with the word "Sample".
- Courses available only to persons with definite trade qualifications. These are marked in the following list with the word "Closed".

AMENDMENTS.

APPENDIX—continued.

Name of Subject.	Classification.	State in which Available.
Rural Courses—		
Stage I., Agriculture P. ..	N.S.W.
Stage II., Agriculture P. ..	
Animal Husbandry P. ..	
Farm Mechanics—		
(a) Farm Machinery Basic ..	
(b) Farm Science Basic ..	
(c) Farm Arithmetic Basic ..	
N.B.—(No fee is charged for Farm Arithmetic if taken in conjunction with one of the two preceding subjects).		
Pig Raising Basic ..	
Poultry Farming Basic ..	
Sheep and Wool Closed ..	W.A.
Station Bookkeeping Basic ..	
Agriculture (Preliminary) Basic ..	
Agriculture I. P. ..	
Animal Husbandry P. ..	
Farm Mechanics—		
(a) Farm Arithmetic Basic ..	
(b) Farm Science Basic ..	
Genetics P. ..	
Poultry Farming P. ..	
Preliminary Botany P. ..	
Woolclassing P. ..	
Agriculture (Stage I.) P. ..	Qld.
Pig Raising Basic ..	
Poultry Farming Basic ..	
Sheep (Stage I.) Closed ..	
Station Bookkeeping P. ..	
Wool (Stage I.) Closed ..	
Agriculture I. P. ..	
Pig Raising Basic ..	
Poultry Farming Basic ..	
Wool Classing P. ..	
Art Courses.— (N.B.—Applicants for these courses must forward a sample of work so that a starting point can be determined.)		
Figure Drawing Closed ..	N.S.W.
Freehand Drawing Sample ..	
Lettering and Layout Sample ..	
Rendering Closed ..	

AMENDMENTS.

APPENDIX—*continued.*

Name of Subject.	Classification.	State in which Available.
<i>Art Courses—continued.</i>		
Sketching Sample ..	N.S.W., W.A.
Short Display Card Writing ..	*Basic ..	N.S.W., Tas.
Ticket Writing	*Basic ..	N.S.W.
*(The above N.S.W. courses are conducted by the Architectural Department.)		
Commercial Art (Elementary) ..	Basic ..	Vic., W.A., S.A., Qld.
Commercial Art (L-W)	Sample ..	Vic.
Lettering	Sample ..	Vic., W.A., Tas.
Showcard and Ticket Writing ..	Sample ..	Vic., W.A.
Design (Elementary)	Closed ..	} Vic. (for teachers)
Model Drawing	P. ..	
Perspective (Elementary) ..	Closed ..	
Plant Form	Closed ..	
Geometric Drawing (Art) ..	Closed ..	
*Blackboard Illustration Parts I. and II.	P. ..	} S.A.
*Design and Colour, Parts I. and II.	P. ..	
*Dimensioned Sketching, Parts I. and II.	P. ..	
*Freehand Drawing, Parts I. and II.	P. ..	
Geometrical Drawing, Parts I. and II.	P. ..	
*Object Drawing (S.A.), Parts I. and II.	P. ..	}
Perspective (S.A.), Part I.	P. ..	
*Plant Drawing, Parts I. and II.	P. ..	
Lettering and Showcard Writing, Parts I. and II.	P. ..	

* These subjects have been withdrawn temporarily. Education Officers will be notified when they become available again.

Carpentry and Building Trade Courses. (Subjects in brackets, although to be treated as separate from the point of view of fee deposit, should be taken together, one stage to be taken at a time.)—

Name of Subject.	Classification.	State in which Available.
<i>Building Construction Course—</i>		
<i>Building Construction—</i>		
Theory I., II., III. ..	Closed ..	} N.S.W.
Drawing I., II., III. ..	Closed ..	
Calculations I., II., III. ..	Closed ..	
<i>Building Construction, Stage I.—</i>		
(a) Building Construction and Drawing I.	Closed ..	} Qld.
(b) Building Trades Calculations	Closed ..	
(c) Technology of Building Materials	Closed ..	

AMENDMENTS.

APPENDIX—*continued.*

Name of Subject.	Classification.	State in which Available.
<i>Carpentry and Joinery Course—</i>		
<i>Carpentry and Joinery—</i>		
Theory I., II., III. ..	Closed ..	} N.S.W.
Drawing I., II., III. ..	Closed ..	
Calculations I., II., III. ..	P. ..	
Carpentry and Joinery—I, II., III., IV., V.	Closed ..	W.A.
Trade Work and Trade Drawing (Carpentry and Joinery)	Closed ..	Qld.
Builders' Quantities (Timber)	Closed ..	Vic., S.A., Tas., W.A.
Builders' Quantities (Brick Buildings)	Closed ..	Vic., W.A., S.A., Tas.
Concrete Engineering ..	P. ..	Vic., Tas.
Timber Measuring ..	Basic ..	Vic., Qld., Tas.
<i>Commercial and Clerical Courses—Accountancy Courses—</i>		
*Bookkeeping (and Station Book-keeping)	P. ..	} N.S.W.
Business Principles ..	Basic ..	
Commercial Correspondence ..	P. ..	} N.S.W.
Accountancy I. and II. ..	P. ..	
Auditing I. ..	P. ..	
Commercial Law I. and II. ..	P. ..	
Accountancy III. and IV. ..	P. ..	
Auditing II. ..	P. ..	
Commercial Law III. and IV. ..	P. ..	
Cost Accountancy ..	P. ..	
* These subjects may be taken separately.		
Bookkeeping (Preliminary and General)	Basic ..	Vic., S.A., Qld., Tas., W.A.
Commercial Correspondence ..	P. ..	Vic., S.A., Qld., N.S.W.
Bookkeeping (Intermediate) ..	P. ..	Vic., W.A., S.A., Qld., Tas.
Auditing (Intermediate) ..	P. ..	Vic., W.A., S.A., Qld., Tas.
<i>Or,</i>		
Auditing (Intermediate) based on Text Book	P. ..	Vic.
Mercantile Law (Intermediate) ..	P. ..	Vic.
<i>Or,</i>		
Mercantile Law (Intermediate) based on Text Book	P. ..	Vic., S.A., Qld., Tas.
Bookkeeping (Final) ..	P. ..	Vic., S.A., Qld.
Auditing (Final) ..	P. ..	Vic., S.A., Qld.
Mercantile and Trustee Law (Final)	P. ..	Vic., S.A. (Mercantile Law only).
Company Law ..	P. ..	Vic.
Bankruptcy Law ..	P. ..	Vic., S.A., Qld.

AMENDMENTS.

APPENDIX—continued.

Name of Subject.	Classification.	State in which Available.
<i>Commercial and Clerical Courses—Accountancy Courses—continued.</i>		
Banking Finance and Foreign Exchange	P. ..	Vic., S.A.
Income Tax Law and Practice	P. ..	Vic., S.A.
Federal Income Tax Law	P. ..	Qld., N.S.W.
Industrial Cost Accounting (Managerial and Industrial Organization of Accounting)	P. ..	Vic.
Cost Accounting	P. ..	Vic.
N.B.—Certain subjects of the Melbourne Technical College Diploma Course are covered by the above subjects (<i>vide</i> Education Officers' Handbook, Section 2, page 40).		
Station Bookkeeping	P. ..	S.A., Qld., N.S.W.
Business Principles	Basic ..	S.A., Qld., Vic.
Commercial Correspondence	P. ..	S.A., Qld., Vic.
<i>Secretarial Courses—</i>		
Handwriting	Basic ..	Vic., Tas.
Shorthand (Pitman's)	P. ..	Tas., N.S.W., Vic., W.A., S.A., Qld.
Typewriting	Basic ..	N.S.W.
Secretarial Knowledge and Duties	P. ..	Vic., S.A.
Company Formation and Administration	P. ..	Vic., S.A.
Legality and Conduct of Meetings	P. ..	N.S.W.
Company Secretarial Practice	P. ..	N.S.W.
<i>Bankers' Institute Courses (Vic.)—</i>		
Practical Banking (Intermediate)	P.	
Bookkeeping (Part I, for Bankers' Institute)	P.	
Commercial Law (Intermediate)	P.	
Economics of Commerce (Intermediate)	P.	
Economic Geography (Intermediate)	P.	
Advanced Practical Banking (Final)	P.	
Bookkeeping (Part II, for Bankers' Institute)	P.	
Commercial Law (Final)	P.	
Banking Law (Final)	P.	
Banking, Currency, and Exchange (Final) (as for Banking, Finance, and Foreign Exchange, Accountancy Group II.)	P.	
Securities	P.	

AMENDMENTS

APPENDIX—continued.

Name of Subject.	Classification.	State in which Available.
<i>Local Government Clerks Course (N.S.W.)—</i>		
Stage I.—		
(a) Local Government English	Closed ..	} N.S.W.
(b) Local Government Arithmetic	Closed ..	
(c) Local Government Book-keeping	Closed ..	
Stage II.—		
(a) Local Government Accounts I. and II.	Closed ..	} N.S.W.
(b) Local Government Law I. and II.	Closed ..	

Contributory Courses (Technical). (The following subjects form part of the syllabus of instruction for Melbourne Technical College diploma and certificate courses in Mechanical, Civil, and Electrical Engineering, &c.).

Name of Subject.	Classification.	State in which Available.
<i>Mathematics—</i>		
<i>Technical—</i>		
Mathematics IA. Algebra	P. ..	} Vic.
Mathematics IB. Trigonometry	P. ..	
Mathematics IC. Geometry	P. ..	
Mathematics IIA. Pure Mathematics	P. ..	
Mathematics IIB. Applied Mathematics	P. ..	
Mathematics IIC. Calculus	P. ..	
Mathematics — Advanced Mathematics for Chemistry Diploma	P. ..	
Mathematics IIIA. (Pure)	P. ..	
Mathematics IIIB. (Applied)	P. ..	
<i>Physics—</i>		
Grade IA., Physics (Mechanics and Heat)	P. ..	} Vic.
Grade IB., Physics (Sound and Light)	P. ..	
Grade IC., Physics (Electricity and Magnetism)	P. ..	
(See also Preparatory Courses)	P. ..	

AMENDMENTS.

APPENDIX—continued.

Name of Subject.	Classification.	State in which Available.
<i>Mathematics—continued.</i>		
<i>Applied Mechanics—</i>		
Grade II., Applied Mechanics (Strength of Materials)	P. ..	} Vic.
Grade IIIA., Applied Mechanics (Structures)	P. ..	
Grade IIIB., Applied Mechanics (Machines)	P. ..	
<i>Engineering Drawing—</i>		
Engineering Drawing (Preliminary)	Basic ..	} Vic.
Drawing I.	Closed ..	
Drawing II.A. (Structures)	Closed ..	
Drawing II.B. (Machines)	Closed ..	
Drawing IIIA. (Structures)	Closed ..	
Drawing IIIB. (Machines)	Closed ..	

The following subjects form part of the syllabus of instruction for the Brisbane Technical College diplomas in mechanical and electrical engineering:—

Name of Subject.	Classification.	State in which Available.
<i>Diploma in Mechanical and Electrical Engineering—</i>		
Algebra	P. ..	} Qld.
Geometry	P. ..	
Trigonometry	P. ..	
Mechanical Drawing I.	P. ..	
(Other subjects in preparation)		

Electrical Trade—

Electrical Theory, Stage I.	.. } Closed ..	} N.S.W.
Trade Calculations, Stage I.	.. }	
Applied Electricity (D.C.), Stage II. and III.	.. }	
Trade Calculations, Stages II. and III.	Closed ..	
Trade Drawing, Stages II. and III.	.. }	
Applied Electricity (A.C.), Stages IV. and V.	.. }	
Trade Calculations, Stages IV. and V.	Closed ..	

AMENDMENTS.

APPENDIX—continued.

Name of Subject.	Classification.	State in which Available.	
<i>Electrical Trade—continued.</i>			
Preparatory Electrical Theory ..	Basic ..	} Vic., W.A., Qld.	
Preliminary Wiring, Grade I. ..	Basic ..		
Electric Wiring, Grade I. ..	Closed ..	} Vic.	
Electric Wiring, Grade II. ..	Closed ..		
Electric Wiring, Grade III. ..	Closed ..		
"B" Grade Wiring, Revision ..	Closed ..		
"A" Grade Wiring, Revision ..	Closed ..		
Trade Mathematics (for Electrical Apprentices)	Basic ..		
Electrical Fitting Theory (2nd Year Electrical Apprentices)	Closed ..		
Electrical Science for Radio (see Radio Courses)	Basic ..		
Illumination	P. ..		
Trade Drawing }		} Qld.
Electrical Principles I. }		
Trade Mathematics II. }		
Trade Work I., II., and III. ..	Closed ..		
Electrical Principles II. and III.	Closed ..		
Applied Electricity I., II., III., and IV.	Closed ..		
Radio Communications I. and II.	Closed ..		
<i>Engineering Trade and Allied Courses—</i>			
Diesel Engine Operation ..	Basic ..	} N.S.W., Tas., Qld.	
Engineering Trades Drawing, Stages I., II., and III.	Basic ..		
Engineering Trades Calculations, Stages I., II., and III.	Basic ..	} N.S.W.	
*Fitting and Machining—	.. }		
Theory I., II., and III. }		
Calculations I., II., and III. }		
Drawing I., II., and III. ..	Basic ..		
* Stage I. is temporarily unavailable.			
Motor Maintenance	Basic ..	} Tas., N.S.W., Qld. (P.).	
Suction (Producer) Gas Engine	Basic ..		
<i>Driving</i>			
Steam Engine Driving and Boiler Attendants	Basic ..	} N.S.W., Tas. (closed).	
Basic Workshop Theory ..	Basic ..		
Boiler Attendance	Closed ..	} Vic., S.A.	
Engine-driving—	.. }		
Second-class	Closed ..		
First-class	Closed ..	} Vic.	

AMENDMENTS.

APPENDIX—continued.

Name of Subject. Classification. State in which Available.
Engineering Trade and Allied Courses—continued.

General Engineering Machine Shop Theory	Closed ..	Vic.
Air Conditioning (General)	.. Closed ..	W.A.
Welding (Electric)	.. Closed ..	W.A., Vic.
Welding (Oxy Acetylene)	.. Closed ..	Vic.
Internal Combustion Engines (including Diesel)	P. ..	W.A.

Fitting and Turning Course (Brisbane)—

Trade Work I., II., and III.	.. Closed ..	} Qld.
Trade Drawing	.. Closed ..	
General Science	.. Closed ..	
Trade Mathematics I. and II.	.. Closed ..	
Mechanical Drawing I. and II.	.. Closed ..	
Engineering Chemistry	.. Closed ..	
Elementary Heat Engines	.. Closed ..	
Oxy Welding	.. Closed ..	

Motor Mechanics Course (Brisbane)—

Trade Work, Trade Drawing, General Science, Trade Mathematics, and Engineering Chemistry as above and—		} Qld.
Mechanical Drawing I.	.. Closed ..	
Car Electrics I. and II.	.. Closed ..	

Mining Courses—

Mining I.	P. ..	} W.A.
Mining II.	P. ..	
Metallurgy I.	P. ..	
Ore Dressing I.	P. ..	
*Assaying I.	P. ..	

*(Applicants will not be enrolled for this subject unless they have access to an assay laboratory.)

Miscellaneous Courses—

Air Conditioning	Closed ..	W.A.
Breadbaking	Closed ..	Vic.
Colloquial Malay	P. ..	W.A.
Concrete Engineering	P. ..	Vic., Tas.
Elementary Japanese	P. ..	Vic.
Foremanship (see Works Supervision)	Closed ..	Tas.
Forestry	P. ..	Vic.
Geology I. (Theory)	P. ..	Vic.

AMENDMENTS.

APPENDIX—continued.

Name of Subject. Classification. State in which Available.
Miscellaneous Courses—continued.

Interior Decoration	P. ..	Vic., W.A., Qld.
Licensed Land Brokers' Course	P. ..	S.A.
Road Board and Municipal Officers' Course	Closed ..	W.A.
Road and Street Engineering (including Swimming Baths and Airports)	P. ..	Vic.
Rudiments of Music (Theory Grades 6, 5, 4)	P. ..	Vic.
Salesmanship	P. ..	Vic., W.A., Qld., Tas., S.A.
Works Supervision	Closed ..	Vic., Qld.

Pharmacy—

First Year—			
(i) Inorganic Chemistry (Theory)	} Qld.	
(ii) Botany (Theory)		
(iii) Pharmacy I. (Theory)		
Second Year—			
(i) Inorganic Chemistry (Theory)	} Qld.	
(ii) Materia Medica (Theory)		
(iii) Pharmacy II. (Theory)		
Third Year—			
Organic Chemistry (Theory)		Qld.

N.B.—For Victorian College of Pharmacy Courses, see Private Institutions.

Printing Trade Courses—

Composing, Stages I., II. and III.	Closed ..	} N.S.W.
Printers' English and Arithmetic (Stages I. and II.)	Closed ..	
Linotype Operation	} Vic.
Composing, Grade I.	
Composing, Grade II.	
Printing Trade English	.. P. ..	} W.A.
Printing Trade Mathematics	.. P. ..	
Printing Trade Drawing	.. P. ..	
Printing Machining, Stages I., II., III., IV., and V.	Closed ..	} W.A.
Printing Composing, Stages I., II., III., IV., and V.	Closed ..	

AMENDMENTS.

APPENDIX—continued.

Name of Subject.	Classification.	State in which Available.
<i>Public Health Courses—</i>		
Health Inspection Course—		
Elementary Public Health Science	} P.	} N.S.W.
History and Survey of Local Government (for further subjects see "Handbook")		
Meat Inspection Course—		
Practical Sanitation	.. } P.	.. } N.S.W.
Meat Inspection	.. }	.. }
Country Town Drainers' and Water Plumbers' Course—		
House Drainage	.. } *Basic	.. } N.S.W.
Water Plumbing	.. }	.. }
Country Town Sewer Plumbing Course—		
Sewer Plumbing Stages I. and II.	*Basic	

* (Subjects in the above two courses are not "closed", but are not recommended to persons who have not had practical experience.)

Radio Courses—

Electrical Science (for Radio)	.. Basic	.. Vic.
Radio Receiving (Theory)	.. Closed	.. Vic.
Radio Servicing, Maintenance, and Repairs (Theory)	Closed	.. Vic.

Refrigeration—

Refrigeration (Electric)	.. Closed	.. Qld., S.A., Vic., Tas.
Refrigeration (Domestic)	.. Closed	.. W.A.
Refrigeration (Commercial)	.. Closed	.. W.A.

Surveyors' Courses—

Land Surveying I., II., and III.	Closed	.. }
Laws and Regulations for Surveyors	Closed	.. }
Forestry	.. P.	.. }
Geology I.	.. P.	.. }

AMENDMENTS.

APPENDIX—continued.

Name of Subject.	Classification.	State in which Available.
<i>Women's Home and Handcraft Courses—</i>		
Dressmaking—		
Designing and Cutting, Stages I. and II.	} Basic	} ..
Making, Stages I. and II.		
Millinery	.. Basic	.. }
Dressmakers' and Milliners' Art—		
Stage I.—Freehand Drawing and Drapery Drawing	} P.	} ..
Stage II.—Drapery Drawing and Design		
Dressmaking, Stage I.	.. P.	.. Qld.
Home Management	.. Basic	.. Vic., S.A., Qld., Tas., W.A.
<i>X-Ray Courses—</i>		
Anatomy and Physiology (First Year)	P.	.. }
X-Ray Physics I. (First Year)	.. P.	.. }
X-Ray Chemistry (First Year)	.. P.	.. }
Positioning (Second Year)	.. Closed	.. }
Physics II. (Second Year)	.. Closed	.. }

SECTION III.

Some subjects which form part of the prescribed course of study for the degrees of Bachelor of Arts, Bachelor of Economics or Commerce, and Bachelor of Laws are available through the following Universities. At present no fee deposit is required in respect of these subjects.

University of Sydney.
 University of Melbourne.
 University of Queensland.
 University of Adelaide
 University of Western Australia.
 University of Tasmania.

Students who wish to study for the degree of Bachelor of Science may take Mathematics.

AMENDMENTS.

APPENDIX—*continued.*

Subjects are available for diploma courses as follows:—

(i) University of Melbourne—

Diploma of—

Commerce
Education
Journalism.
Public Administration
Social Studies
Physical Education.

(ii) University of Sydney—

Diploma of—

Public Administration
Education
Social Studies.

(iii) University of Queensland—

Diploma of—

Education
Music
Journalism.

Also Certificate Courses in Education and Accountancy.

(iv) University of Adelaide—

Diploma of—

Commerce
Public Administration
Education
Social Science.

(v) University of Tasmania—

Diploma of—

Commerce
Public Administration.

Education Officers will be supplied with details of subjects available, and notified of the final date for enrolment at each University.

AMENDMENTS.

APPENDIX—*continued.**Courses for Teachers—*

N.S.W. .. Correspondence instruction is available to personnel who, at the time of enlistment, were students of the Sydney or Armidale Teachers' Colleges or who had been accepted for admission to one of the above Colleges.

Qld. .. Correspondence instruction is available through the Department of Public Instruction, Brisbane, in all the subjects required for the Departmental Examination for admission as Teacher of Classes II. and III. Enrolment is not restricted to teachers.

W.A. .. Teachers' Certificate "B" (Closed).

(i) Education IA.

(ii) Education IB.

(iii) History.

(iv) Arithmetic.

Other subjects of this certificate, and also Teachers' Certificate "A" (Education, English Literature and History, each in three stages) have been approved and will be available shortly.

PRIVATE INSTITUTION COURSES.

Name of Subject.	Classification.	State in which Available.
<i>Pelman Courses—</i>		
Pelmanism	Basic ..	The Pelman Institute.
<i>Postal Courses—</i>		
(a) Commonwealth Clerical Examination	Closed ..	The Victorian Postal Institute.
(b) Qualifying Examination for transfer or promotion as Postal Clerk, Senior Postal Clerk or Postmaster	Closed ..	
(c) Qualifying Examination (Educational) for inclusion in 3rd Division	Closed ..	

AMENDMENTS.

APPENDIX—*continued.**Radio Courses—*

Broadcast Operators (3 units—A, B, and C)	Closed	..	} Marconi School of Wireless, Sydney.
First Class Commercial Operators (3 units—A, B, and C)	Closed	..	

<i>Marine Engineering Courses</i>	..	Closed	..	B.I.E.T., I.C.S.
-----------------------------------	----	--------	----	------------------

<i>Ship Building and Naval Architecture</i>	Closed	..	} B.I.E.T., Sydney	
<i>Ground Engineers' Licence</i>	..	Closed		..
<i>A.F.R.Ac.S. Examination Courses</i>	..	Closed		..
<i>A.M.I.E.E. Examination Courses</i>	..	Closed		..
<i>A.M.I.Mech.E. Examination Courses</i>	Closed	

N.S.W. Railways Institute Courses—

Internal Combustion Engines (Elementary)	Basic	..	} N.S.W. Railways Institute, Sydney.
Diesel Engines (Elementary)	..	Basic	

<i>Advertising</i>	P.	..	} School of Applied Advertising, Sydney. International Correspondence School, Sydney. Hemingway Robertson Institute, Melbourne.
--------------------	----	----	----	----	---

<i>Grocery Courses</i>	Retail Storekeepers' Association, South Australia.
------------------------	----	----	----	----	--

Pharmacy—

Introductory Course (V.C.P.)	..	P.	..	} Victorian College of Pharmacy.
First Year Course (V.C.P.)	..	Closed	..	
Second Year Course (V.C.P.)	..	Closed	..	

AMENDMENTS.

